

1100X SERIES WIRELESS RECEIVER

Installation Guide

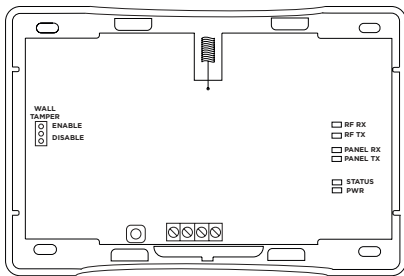

Figure 1: 1100X Series Wireless Receiver

DESCRIPTION

The 1100X Series Wireless Receiver provides up to 100 wireless zones for XR150 Series panels and up to 500 wireless zones for XR550 Series panels. The 1100XE features 128-bit AES encryption.

The 1100X also provides two-way communication using 900 MHz frequency hopping-spread-spectrum technology.

The 1100X is equipped with a case and wall tamper.

Compatibility

- XR150/XR550 Series Panels
- Encryption requires panel Version 183 or higher
- 1100T Translator requires receiver firmware Version 207/301 or higher

What is Included?

- 1100X Wireless Receiver
- Model 300 Harness
- Hardware Pack



1 PROGRAM THE PANEL

Refer to the panel programming guide as needed.

1. Reset the panel.
2. At a keypad, enter **6653** (PROG) to access the **PROGRAMMER** menu.
3. In **SYSTEM OPTIONS**, program a **HOUSE CODE** between 1 and 50. See *House Code Explained* for more information.
4. (1100XE only) At the **1100 ENCRYPTION** prompt, select **ALL** to only add encrypted wireless devices to the system. Select **BOTH** to allow both encrypted and non-encrypted wireless devices to be programmed.
5. (1100XE only) The default passphrase appears at **ENTER PASSPHRASE**. Press **CMD** to keep the default. Press any select key or area to change the passphrase and enter an 8-character hexadecimal string (0-9, A-F).
6. Press **CMD** until **STOP** displays. Press a top row select key or area to save programming.

2 SELECT A LOCATION

The receiver should be centrally located between the DMP panel and the 1100 Series transmitters used in the installation based on the wiring specifications below. Use an 1106 Series Universal Wireless Transmitter to perform an LED survey.

1. With the cover removed, hold the transmitter in the desired location.
2. Press the tamper switch to send data to the panel and determine if communication is confirmed or faulty.

✓ **Confirmed:** If communication is confirmed, for each press or release of the tamper switch, the LED blinks immediately on and immediately off.

✗ **Faulty:** If communication is faulty, the LED remains on for about 8 seconds or flashes multiple times in quick succession. Relocate the receiver until the LED confirms clear communication.

3 MOUNT THE 1100X

1. Remove the cover from the plastic housing.
2. Use the included #6 screws to secure the 1100X to the wall. See Figure 2 for mounting hole locations.
3. Use one of the provided screws to secure the wall tamper. See Figure 2 for tamper location.

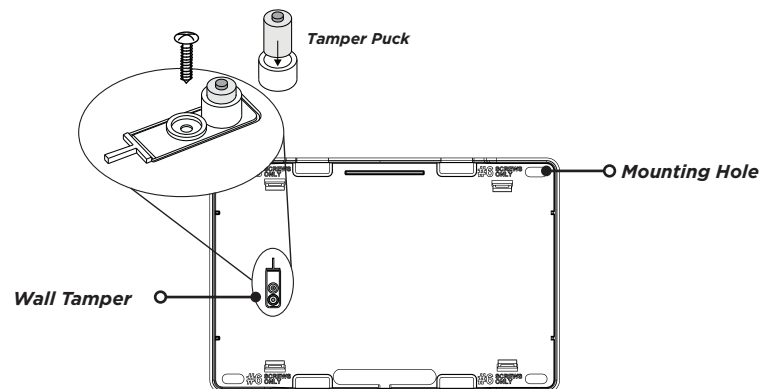

Figure 2: Inside of the 1100X Housing

4

WIRE THE RECEIVER

The panel immediately recognizes the 1100X if the panel is programmed with a house code. Do not use shielded wire between the panel and receiver.

1. Connect the red, yellow, green, and black wires to the PANEL terminal on the 1100X.
2. Connect the other end of the wires to the XBUS on the panel. See Figure 2.
3. Snap the cover back on to the base.



Note: The receiver can't operate if it's connected to the keypad bus.

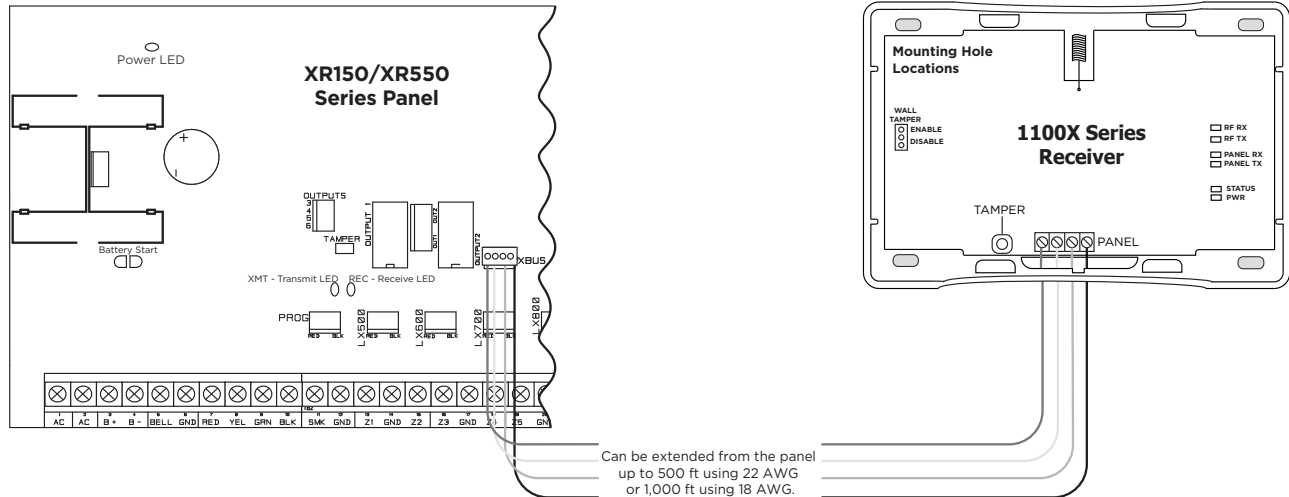

Figure 3: Wire the 1100X to the Panel

ADDITIONAL INFORMATION

Wiring Specifications for X-Bus

1. DMP recommends using 18 or 22-gauge **unshielded** wire for all keypad and LX-Bus circuits. **Do Not** use twisted pair or shielded wire for LX-Bus and Keypad Bus data circuits. To maintain auxiliary power integrity when using 22-gauge wire do not exceed 500 feet. When using 18-gauge wire do not exceed 1,000 feet. Install an additional power supply to increase the wire length or add devices.
2. Maximum distance for any one circuit (length of wire) is 2,500 feet regardless of the wire gauge. This distance can be in the form of one long wire run or multiple branches with all wiring totaling no more than 2,500 feet. As wire distance from the panel increases, DC voltage on the wire decreases.
3. Maximum number of devices per 2,500 feet circuit is 40.
4. Maximum voltage drop between the panel (or auxiliary power supply) and any device is 2.0VDC. If the voltage at any device is less than the required level, add an auxiliary power supply at the end of the circuit. When voltage is too low, the devices cannot operate properly. Refer to the panel installation guide and LX-Bus/Keypad Bus Wiring Application Note (LT-2031).

Programming Zones

Refer to the panel XR150/XR550 Series Programming Guide (LT-1232) for complete wireless programming information. When any wireless input zone for a particular address is programmed, the 1100XH responds to the panel for this address. Other devices, such as keypads or hardwired zone expanders, cannot use this address. Zones connected directly to the panel cannot be wireless. See Table 1 for designated zone numbers.

DMP PANEL	AVAILABLE ZONES	ZONE RANGES
XR150 (1100X Series)	100	500 - 599
XR550 (1100X Series)	500	500 - 999

Table 1: Zone Number Designations

1100X LED Operation

The six labeled LEDs on the 1100X PCB display wireless receiver operation and activity.

See Table 2 for LED locations and Table 1 for LED indications.

House Code Explained

The house code identifies the panel, receiver, and transmitters to each other. The 1100X automatically sends the specified house code to wireless transmitters when transmitter serial numbers are programmed into the panel. The 1100X only listens for transmissions using the specified house code or the programmed transmitters' serial numbers.

LED	INDICATIONS
RF RX	Flashing yellow indicates data is being received from a transmitter.
RF TX	Flashing green indicates data is being sent to a transmitter.
PANEL RX	Flashing yellow indicates data is being received from a panel.
PANEL TX	Flashing green indicates data is being sent to the panel.
STATUS	Solid red indicates memory is being uploaded. Turns off when complete.
PWR	Solid green indicates there is power to the wireless receiver.

Table 2: LED Indications

Transmitter Supervision Time

For listed installations, program the transmitter supervision time in panel zone programming as listed in the following table. Refer to the panel programming guide for complete wireless programming information.

UL Listing	Listed Accessories	Supervision Time
UL 268 Smoke-Automatic Fire Detectors	1164 Synchronized Smoke Detector 1164NS Smoke Detector with No Sounder 1168 Smoke/CO/Low Temp Detector	3
UL 365 Police Station Connected Burglar Accessory	1103 Universal Transmitter	60
UL 521 Heat Detectors for Fire Protective Signaling Systems	1183-135F, 1183-135R Heat Detector	3
UL 609 Local Burglar Alarm Units and System Accessory	1103 Universal Transmitter	60
UL 634 Connections and Switches for use with Burglar Alarm Systems Accessory	1101, 1102, 1103, 1106 Universal Transmitters	60
UL 636 Holdup Alarm Units and Systems Accessory	1142 Two-Button Holdup Transmitter	60
UL 639 Intrusion Detection Units Accessory	1127W, 1127C PIR Motion Detectors	60
UL 864 Fire Protective Signaling Systems	1103 Universal Transmitter	3
UL 985 Household Fire Warning System Accessory	1135 Siren 9060, 9063, 9862 Wireless Keypads	240
UL 1023 Household Burglary System Units Accessory	1101, 1102, 1103, 1106 Universal Transmitters 1127W, 1127C PIR Motion Detectors 1135 Siren 1142 Two-Button Holdup Transmitter 9060, 9063, 9862 Wireless Keypads	60
UL 1076 Proprietary Burglar Alarm Units Accessory	1103 Universal Transmitter 9862 Wireless Graphic Touchscreen Keypad	60
UL 1610 Central Station Burglar Alarm Units Accessory	1103 Universal Transmitter 1135 Siren 9060, 9063, 9862 Wireless Keypads	60
UL 2075 Gas and Vapor Detectors and Sensors	1184 Wireless Carbon Monoxide Detector 1168 Wireless Smoke/CO/Low Temp Detector	240

Table 3: Wireless Transmitter Supervision Times

 **Note:** The 1100R Wireless Repeater and 1100T Wireless Translator follow the Receiver Supervision times for Listed Accessories.

LISTED COMPLIANCE SPECIFICATIONS

For applications that must conform to a National Recognized Testing Laboratory certified system, read the information below for additional information.

Commercial Fire

Transmitters must be programmed as supervised. Refer to Table 3 for specific supervision times. The maximum line impedance of the 4-wire bus is 16.2 Ohms for 1,000 feet (305 meters). The recommended wire gauge for panel to receiver connection is 22 AWG.

After all transmitters are in position, the WLS option of the panel's Walk Test must be operated and all transmitters programmed for Fire (FI) or Supervisory (SV) must show that their check-in message was received. Refer to the panel programming guide for Trip Counter for DMP Wireless Check-in Test (WLS) which describes that both numbers of the counter must match. If not and a failed wireless zone is displayed at END, decrease that transmitter's range with the receiver and perform the Wireless Walk Test again.

FCC INFORMATION

This device complies with Part 15 of the FCC Rules. Operation is subject to the following two conditions:

1. This device may not cause harmful interference, and
2. this device must accept any interference received, including interference that may cause undesired operation.

The antenna used for this transmitter must be installed to provide a separation distance of at least 20cm (7.874 in.) from all persons. It must not be located or operated in conjunction with any other antenna or transmitter.

Changes or modifications made by the user and not expressly approved by the party responsible for compliance could void the user's authority to operate the equipment.



Note: This equipment has been tested and found to comply with the limits for a Class B digital device, pursuant to part 15 of the FCC Rules. These limits are designed to provide reasonable protection against harmful interference in a residential installation. This equipment generates, uses and can radiate radio frequency energy and, if not installed and used in accordance with the instructions, may cause harmful interference to radio communications. However, there is no guarantee that interference will not occur in a particular installation. If this equipment does cause harmful interference to radio or television reception, which can be determined by turning the equipment off and on, the user is encouraged to try to correct the interference by one or more of the following measures:

1. Reorient or relocate the receiving antenna.
2. Increase the separation between the equipment and receiver.
3. Connect the equipment into an outlet on a circuit different from that to which the receiver is connected.
4. Consult the dealer or an experienced radio/TV technician for help.

INDUSTRY CANADA INFORMATION

This device complies with Industry Canada Licence-exempt RSS standard(s). Operation is subject to the following two conditions:

1. This device may not cause interference, and
2. this device must accept any interference, including interference that may cause undesired operation of the device.

This system has been evaluated for RF Exposure per RSS-102 and is in compliance with the limits specified by Health Canada Safety Code 6. The system must be installed at a minimum separation distance from the antenna to a general bystander of 7.87 inches (20 cm) to maintain compliance with the General Population limits.

Le présent appareil est conforme aux CNR d'Industrie Canada applicables aux appareils radio exempts de licence. L'exploitation est autorisée aux deux conditions suivantes:

1. *l'appareil ne doit pas produire de brouillage, et*
2. *l'utilisateur de l'appareil doit accepter tout brouillage radioélectrique subi, même si le brouillage est susceptible d'en compromettre le fonctionnement.*

L'exposition aux radiofréquences de ce système a été évaluée selon la norme RSS-102 et est jugée conforme aux limites établies par le Code de sécurité 6 de Santé Canada. Le système doit être installé à une distance minimale de 7.87 pouces (20 cm) séparant l'antenne d'une personne présente en conformité avec les limites permises d'exposition du grand public.

1100X SERIES WIRELESS RECEIVER

Specifications

Operating Voltage	12 VDC Nominal
Current Draw	25 mA (average), 35 mA (peak)
Frequency Range	905-924 MHz
Housing Dimensions	5.5"W x 3.75"L x 1"H
Housing Color	White
Housing Material	Flame Retardant ABS

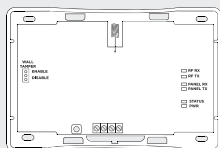

Patents

U.S. Patent Number 7, 239, 236

Ordering Information

- 1100X-W Standard Wireless Receiver
- 1100XE-W Encrypted Wireless Receiver

Certifications

California State Fire Marshal (CSFM)

New York City (FDNY)

FCC Part 15: CCKPC0114R6

Industry Canada: 5251A-PC0114R6

Underwriters Laboratory (UL) Listed

- ANSI/UL 365 Police Station Connected Burglar
- ANSI/UL 609 Local Burglar Alarm Unites and Systems
- ANSI/UL 1023 Household Burglar Alarm System Units
- ANSI/UL 1076 Proprietary Burglar Alarm Units
- ANSI/UL 1610 Central Station Burglar Alarm Units
- ANSI/UL 864 Fire Protective Signaling Systems
- ANSI/UL 985 Household Fire Warning System

Compatible With Devices Listed for:

- ANSI/UL 268 Smoke Detectors for Fire Alarm Signaling Systems
- ANSI/UL 634 Connections and Switches for use with Burglar Alarm Systems Accessory
- ANSI/UL 636 Safety Holdup Alarm Units and Systems
- ANSI/UL 639 Intrusion Detections Units Accessory
- ANSI/UL 2075 Gas and Vapor Detectors and Sensors



Designed, engineered, and
manufactured in Springfield, MO
using U.S. and global components.

LT-1822 1.01 21062

© 2021

INTRUSION • FIRE • ACCESS • NETWORKS

2500 North Partnership Boulevard
Springfield, Missouri 65803-8877

800.641.4282 | DMP.com