

# 1100T WIRELESS TRANSLATOR

## Installation Guide

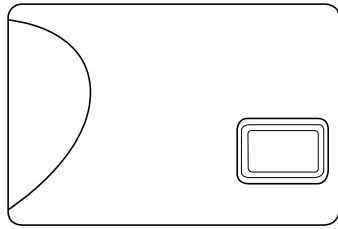

### DESCRIPTION

The 1100T Wireless Translator allows upgrades of non-DMP systems with one-way, low frequency, wireless transmitters to DMP. The 1100T is compatible with transmitters that operate at various MHz such as Interlogix, Honeywell 5800, 2GIG, and DSC. The translator operates with a wireless connection to a DMP panel.

Transmitters that have been learned into the 1100T are able to send supervision and low battery messages to the panel.

### Compatibility

- All DMP XT Series panels and XR Series panels with version 203 or higher
- All 1100 Series Wireless Receivers with version ??? or higher
- Interlogix 319.5 MHz
- Honeywell 5800 345 MHz
- 2GIG Series 345 MHz
- DSC 433 MHz

 **Note:** The 1100T is not compatible with life safety devices.

### What is Included?

- 1100T Wireless Translator
- 12 VDC Power Supply
- Hardware Pack



## 1 PROGRAM THE PANEL

Because the 1100T is a wireless device, all panel programming must be completed in Device Setup and zones should be programmed in Zone Information.

### For XR Series Panels

#### Device Setup

1. Enter **6653** (PROG) at the keypad.
2. Press **CMD** and select **DEVICE SETUP**.
3. At **DEVICE TYPE**, press **CMD** to display options.
4. Press **CMD** again to open the extended options menu.
5. Select **1100T** and press **CMD** to save.
6. Enter the Serial number.
7. At **1100T FREQ**, select any select key or area to select the non-DMP system. Default is **HWL** (Honeywell).
8. Press **CMD**.

#### Zone Information

1. In **ZONE INFORMATION**, enter the wireless zone number.
2. At **\*UNUSED\***, enter the zone name.
3. Select a **ZONE TYPE**.
4. At **DMP WIRELESS**, select **NO**.
5. At **COMP WLS**, select **YES**.
6. At **COMP WLS SRL #**, you can manually enter the serial number of the transmitter or transmit the serial number to the panel:

*Manually:* Press top row key 1 and then begin typing the transmitters serial number.

*Transmit:* To transmit the serial number, choose **LRN** at prompt to display **TRANSMIT NOW**. Tamper the transmitter. Once the panel has received the tamper signal, the serial number will display.

7. Press **CMD**.

### For XT Series Panels

#### Device Setup

1. Enter **6653** (PROG) at the keypad.
2. Press **CMD** and select **DEVICE SETUP**.
3. At **1100T? NO YES**, select **YES** and press **CMD**.
4. Enter the Serial number.
5. At **1100T FREQ** select any select key or area to select the non-DMP system. Default is **HWL**.
6. Press **CMD**.

#### Zone Information

1. In **ZONE INFORMATION**, enter the wireless zone number.
2. At **\*UNUSED\***, enter the zone name.
3. Select a **ZONE TYPE**.
4. At **DMP WIRELESS** select **NO**.
5. At **COMP WLS** select **YES**.
6. At **COMP WLS SRL #**, see Step 6 from the *XR Zone Information* section above.
7. Press **CMD**.

## 2 POWER THE TRANSLATOR

### Wire the Power Supply

The 1100T can be powered from a 12 VDC external power supply. In addition to powering the 1100T, the power supply also charges the back-up battery. If the DC power source is removed, the power failure is indicated as an open condition on the 1100T zone.

The 372-500-W must be located within 100 feet of the panel using 22 AWG wire. Use the following steps to connect the model 372-500-W plug-in DC power supply to the 1100T:

1. Connect the positive wire to the positive terminal on the 1100T.
2. Connect the negative wire to the negative terminal on the 1100T.
3. Plug the power supply into a wall outlet not controlled by a switch.

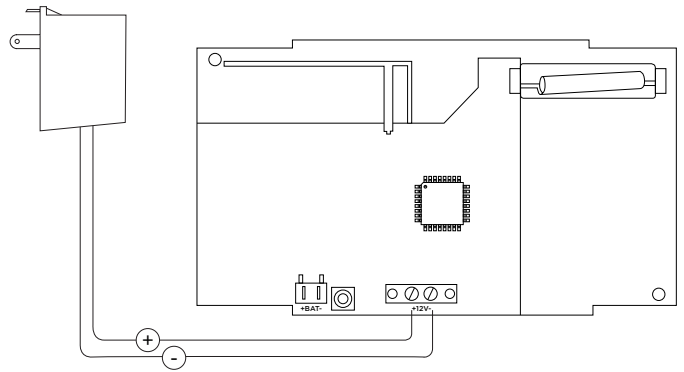

## 3 SELECT A LOCATION

The 1100T translator provides a Survey LED capability to allow one person to confirm communication with the panel while the cover is removed.

1. With the cover removed, hold the translator in the exact desired location.
  2. Press the tamper switch to send data to the panel and determine if communication is confirmed or faulty.
- ✓ **Confirmed:** If communication is confirmed, for each press or release of the tamper switch, the LED blinks immediately on and immediately off. Repeat this test 5 times to confirm ten separate consecutive LED blinks. Any indication otherwise means proper communication has not been established.
  - ✗ **Faulty:** If communication is faulty, the LED remains on for about 8 seconds or flashes multiple times in quick succession. Relocate the translator or receiver until the LED confirms clear communication.

## 4 MOUNT THE TRANSLATOR

The translator must be mounted using the provided #6 screws in the four mounting holes. Mount the translator in a secure, dry place away from metal objects to protect the panel from damage due to tampering or the elements. Mount the translator a minimum of 4 feet from any wireless panels or repeaters. It is not necessary to remove the PCB when installing the enclosure.

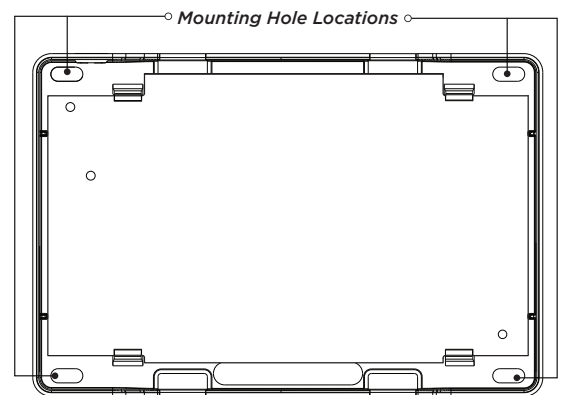

## **ADDITIONAL INFORMATION**

### ***Replace the Battery***

1. Open the translator housing to expose the inside of the 1100T.
2. Remove the PCB board
3. Unplug the battery connector, then remove the old battery
4. Place the new battery in the holder.
5. Connect the battery connector
6. Snap the PCB Board back in place.
7. Snap the cover back on the 1100T.

# FCC INFORMATION

This device complies with Part 15 of the FCC Rules. Operation is subject to the following two conditions:

1. This device may not cause harmful interference, and
2. this device must accept any interference received, including interference that may cause undesired operation.

The antenna used for this transmitter must be installed to provide a separation distance of at least 20 cm (7.874 in.) from all persons. It must not be located or operated in conjunction with any other antenna or transmitter.

Changes or modifications made by the user and not expressly approved by the party responsible for compliance could void the user's authority to operate the equipment.

 **Note:** This equipment has been tested and found to comply with the limits for a Class B digital device, pursuant to part 15 of the FCC Rules. These limits are designed to provide reasonable protection against harmful interference in a residential installation. This equipment generates, uses and can radiate radio frequency energy and, if not installed and used in accordance with the instructions, may cause harmful interference to radio communications. However, there is no guarantee that interference will not occur in a particular installation. If this equipment does cause harmful interference to radio or television reception, which can be determined by turning the equipment off and on, the user is encouraged to try to correct the interference by one or more of the following measures:

1. Reorient or relocate the receiving antenna.
2. Increase the separation between the equipment and receiver.
3. Connect the equipment into an outlet on a circuit different from that to which the receiver is connected.
4. Consult the dealer or an experienced radio/TV technician for help.

# INDUSTRY CANADA INFORMATION

This device complies with Industry Canada Licence-exempt RSS standards. Operation is subject to the following two conditions:

1. This device may not cause interference, and
2. this device must accept any interference, including interference that may cause undesired operation of the device.

This system has been evaluated for RF Exposure per RSS-102 and is in compliance with the limits specified by Health Canada Safety Code 6. The system must be installed at a minimum separation distance from the antenna to a general bystander of 7.87 inches (20 cm) to maintain compliance with the General Population limits.

*Le présent appareil est conforme aux CNR d'Industrie Canada applicables aux appareils radio exempts de licence. L'exploitation est autorisée aux deux conditions suivantes:*

1. *l'appareil ne doit pas produire de brouillage, et*
2. *l'utilisateur de l'appareil doit accepter tout brouillage radioélectrique subi, même si le brouillage est susceptible d'en compromettre le fonctionnement.*

*L'exposition aux radiofréquences de ce système a été évaluée selon la norme RSS-102 et est jugée conforme aux limites établies par le Code de sécurité 6 de Santé Canada. Le système doit être installé à une distance minimale de 7.87 pouces (20 cm) séparant l'antenne d'une personne présente en conformité avec les limites permises d'exposition du grand public.*

## 1100T WIRELESS TRANSLATOR

### Specifications

|                   |  |
|-------------------|--|
| Operating Voltage | XX VDC, XX mA  |
| Standby Battery   |  |
| Voltage           | 3.7 VDC  |
| Capacity          | 800 mAh  |
| Type              | Lithium Polymer, rechargeable                                    |
| Standby           | 24 hours   |
| Frequency Range   | 905-924 MHz  |
| Dimensions        | 5.50" W x 3.75" H x 1.00" D<br>13.97cm W x 9.53 cm H x 2.54 cm D |

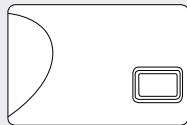

### Ordering Information

|       |                     |
|-------|---------------------|
| 1100T | Wireless Translator |
|-------|---------------------|

### Patents

U.S Patent No. 7,239,236

### Accessories

|               |   |
|---------------|---|
| 1100RBAT800/8 | Replacement rechargeable battery (8 pack) |
| 505-12        | 12 VDC Power Supply                       |
| 372-500-W     | Plug-In DC Power Supply                   |

### Compatibility

- All DMP XT Series panels and XR Series panels with version 203 or higher
- All 1100 Series Wireless Receivers with version ????? or higher
- Interlogix 319.5 MHz
- Honeywell 5800 345 MHz
- 2GIG Series 345 MHz
- DSC 433 MHz

### Certifications

????????????????????????????



Designed, engineered, and manufactured in Springfield, MO using U.S. and global components.

LT-2243 1.01 20XXX

© 2020

INTRUSION • FIRE • ACCESS • NETWORKS

2500 North Partnership Boulevard  
Springfield, Missouri 65803-8877

800.641.4282 | DMP.com