

↗ DOMETIC REFRIGERATION 10-SERIES

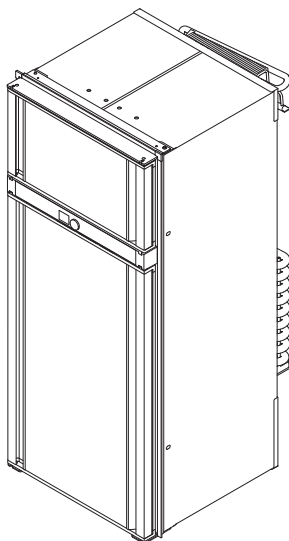

RMD10.5T, RMD10.5XT

EN

Absorption refrigerator

Installation Manual

© 2021 Dometic Group. The visual appearance of the contents of this manual is protected by copyright and design law. The underlying technical design and the products contained herein may be protected by design, patent or be patent pending. The trademarks mentioned in this manual belong to Dometic Sweden AB. All rights are reserved.

Please read these instructions carefully and follow all instructions, guidelines, and warnings included in this product manual in order to ensure that you install, use, and maintain the product properly at all times. These instructions **MUST** stay with this product.

By using the product, you hereby confirm that you have read all instructions, guidelines, and warnings carefully and that you understand and agree to abide by the terms and conditions as set forth herein. You agree to use this product only for the intended purpose and application and in accordance with the instructions, guidelines, and warnings as set forth in this product manual as well as in accordance with all applicable laws and regulations. A failure to read and follow the instructions and warnings set forth herein may result in an injury to yourself and others, damage to your product or damage to other property in the vicinity. This product manual, including the instructions, guidelines, and warnings, and related documentation, may be subject to changes and updates. For up-to-date product information, please visit dometic.com.

Table of Contents

- 1 Explanation of symbols 3
- 2 Safety instructions 4
- 3 Accessories 7
- 4 Installing the refrigerator 8
- 5 Connecting the refrigerator 26
- 6 Technical data 35

1 Explanation of symbols



WARNING!

Safety instruction: Indicates a hazardous situation that, if not avoided, could result in death or serious injury.



CAUTION!

Safety instruction: Indicates a hazardous situation that, if not avoided, could result in minor or moderate injury.



NOTICE!

Indicates a situation that, if not avoided, can result in property damage.



NOTE

Supplementary information for operating the product.

2 Safety instructions

The manufacturer accepts no liability for damage in the following cases:

- Faulty assembly or connection
- Damage to the product resulting from mechanical influences and incorrect connection voltage
- Alterations to the product without express permission from the manufacturer
- Use for purposes other than those described in the operating manual



WARNING! Failure to obey these warnings could result in death or serious injury.

Explosion hazard

- Never open the absorber unit. It is under high pressure and can cause injury if it is opened.
- **Only** operate the device at the pressure shown on the type plate. Only use pressure controllers with a fixed setting which comply with the national regulations (in Europe EN 12864).

Fire hazard

- Ensure clean and residue-free handling if silicon sealant or similar is used. There is a risk of fire if silicone filaments come into contact with hot parts or naked flames.
- Never use a naked flame to check the device for leaks.
- Only use propane or butane gas (**not** natural gas).

Health hazard

- Do not operate the device if it is visibly damaged.
- If the AC power cable for this device is damaged, it must be replaced by the manufacturer, a service agent or a similarly qualified person in order to prevent safety hazards.
- This device may only be repaired by qualified personnel. Inadequate repairs may cause serious hazards.

Risk of asphyxiation

- Dismantle all device doors for the disposal of the old device and leave the shelves in the device to prevent accidental enclosure and suffocation.



CAUTION! Failure to obey these cautions could result in minor or moderate injury.

Electrical shock

- Before starting the device, ensure that the power supply line and the plug are dry.

Risk of crushing

- Do not put your fingers into the hinge.



NOTICE! Damage hazard

- Only hold the device at the body of the device during transport. Never hold the device at the absorber unit, the cooling fins, the gas pipes, the door or the control panel.
- Make sure that the device circuit is not damaged during transportation. The refrigerant in the device circuit is highly flammable.
In the event of any damage to the device circuit (smell of ammonia):
 - Switch off the device if applicable.
 - Avoid naked flames and sparks.
 - Air the room well.
- Do not install the device near naked flames or other heat sources (heaters, direct sunlight, gas ovens etc.).
- **Danger of overheating!**
Always ensure sufficient ventilation so that the heat generated during operation can dissipate. Make sure that the device is sufficiently far away from walls and other objects so that the air can circulate.
- Check that the voltage specification on the type plate is the same as that of the power supply.
- Do not open the refrigerant circuit under any circumstances.
- Only use the AC connection cable supplied to connect the device to the AC mains.
- Only use cables with a suitable size.
- Never pull the plug out of the socket by the connection cable.
- The device may not be exposed to rain.

2.1 Standard AS 4555 safety



WARNING!

- The appliance may be installed by authorised personnel only!
- The unit and the exhaust duct system must be in principle installed so that it is accessible for maintenance work, can easily be installed and dismantled and removed from the vehicle without great effort.
- Installation and connection of the appliance must comply with the latest technical regulations, as follows:
 - The electrical installation must comply with national and local regulations.
 - The gas installation must comply with national and local regulations:
 - AS 5601.2 – Gas Installations
 - NZ 5601 – Gas Appliance Safety
- Install the refrigerator so that it is protected from excessive heat, as this leads to poor performance and increases the power consumption of the refrigerator.
- This refrigerator is provided for installation within Universal gas equipment and must be run exclusively on liquid gas (no natural gas, town gas).
- An AGA Approved LP Regulator must be fitted to the gas supply. The pressure regulator must concur with the operating pressure specified on the rating plate of the appliance. The operating pressure corresponds to the standard pressure of the country of specification.
- Only one connection pressure is permitted for any one vehicle! A plate showing the permanent, clearly legible notice must be displayed in full view at the point where the gas cylinder is installed.
- The gas connection to the appliance must be installed securely and free of stress using pipe connectors and must be securely connected to the vehicle.
- The gas connection to the appliance is 1/8" BSP Female.
- The refrigerator must be equipped with a gas cock in the supply line to allow the supply to be disconnected. Such a cutout device must be readily accessible to the user.

- Before leaving - Check all connections for gas leaks with soap and water. Do not use an unshielded flame for detecting leaks. Ignite the burner to ensure correct operation of gas valve, burner and ignition. When satisfied with the appliance, instruct the user on the correct method of operation. In case the appliance fails to operate correctly after all checks have been carried out, refer to the authorised service provider in your area.

3 Accessories

Description

Dometic gas flue kit 3776

Single lipped sealing for draft-proof installation for gaps of 1 – 5 mm (fig. **8** B, page 16)

Double lipped sealing for draft-proof installation for gaps of 5 – 10 mm (fig. **8** C, page 16)

Winter cover LS 300 for the ventilation grill

Optional Battery Pack R10-BP for stand-alone gas operation

4 Installing the refrigerator



You find the instructions manual for changing the door lock and the decorative plate online at:

documents.dometic.com/?object_id=63258

The device is suitable for installation in:

- caravans
- motor homes

4.1 Preparing the installation



NOTICE!

- The refrigerator may not be installed in the rear of motor homes with the door pointing in the direction of travel.
- Use exclusively original Dometic ventilation grills to ensure safe operation.

When installing the refrigerator, note the following:

- To enable the refrigerant to circulate properly, the refrigerator may not exceed an angle of 3 °.
Park the vehicle horizontally for this purpose.
- The refrigerator must be installed so that
 - it is easily accessible for service work
 - easy to de-install and install
 - can be easily removed from the vehicle

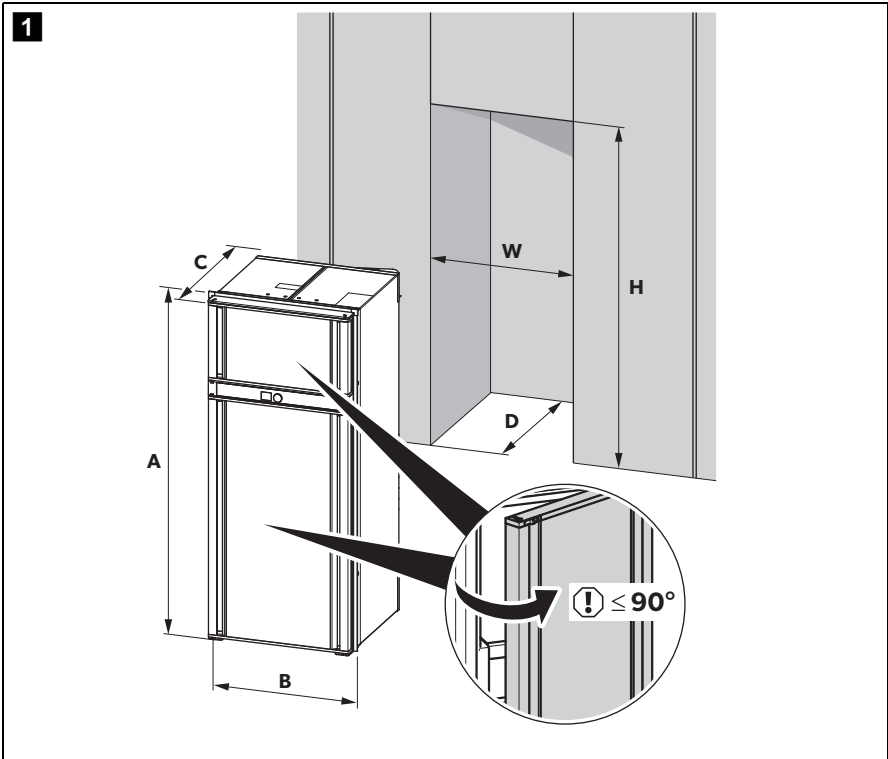

- The refrigerator must be installed in a recess so that it stands secure when the vehicle is in motion. Note the dimensions in fig. **1** for this purpose.

Refrigerator	Overall dimension in mm	
	RMD10.5T	RMD10.5XT
Height (A)	1260	1260
Width (B)	550	550
Depth (C) (excludes control knob 5mm)	550	605

Recess	Dimension in mm	
	RMD10.5T	RMD10.5XT
Height (H)	1252	1252
Width (W)	530	530
Depth (D)	min. 565 – max. 575	min. 520 – max. 630

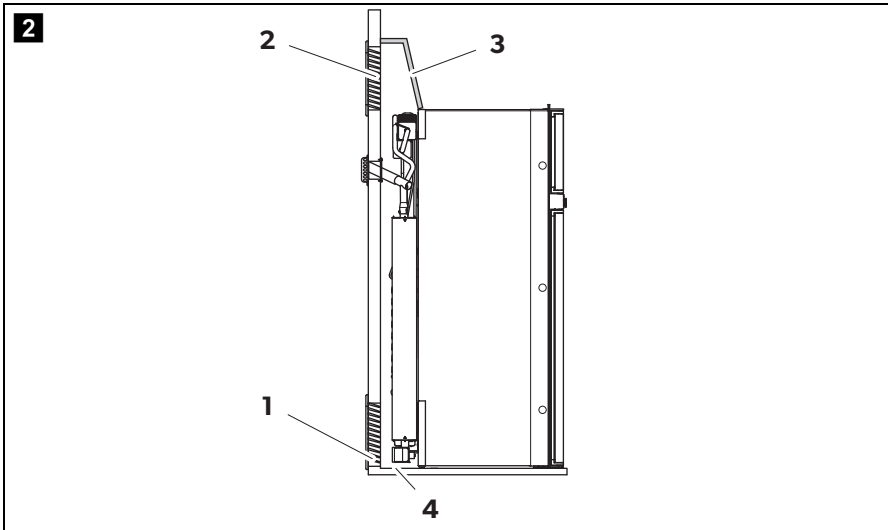

- The outer wall must be fitted with an air inlet vent (fig. **2** 1) and an outlet vent (fig. **2** 2) with ventilation grills so that the heat generated can be easily released to the outside:
 - Air inlet vent: Fit ventilation grill as flush as possible with the base of the installation niche.
 - Outlet vent: fit as far above the refrigerator as possible.
- Fit a heat conduction plate (fig. **2** 3) above the refrigerator so that the heat does not accumulate in the vehicle.

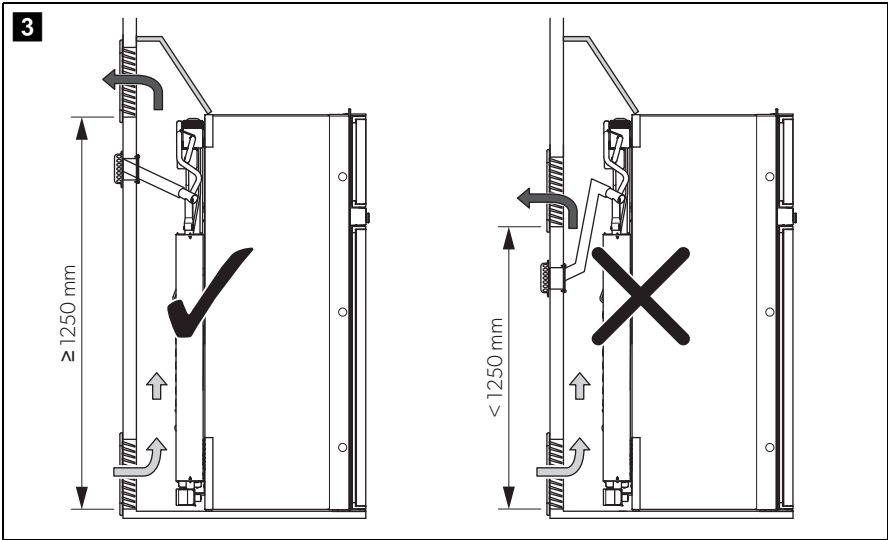

- The distance between the air inlet and outlet vents must be at least 1250 mm (fig. **3**).

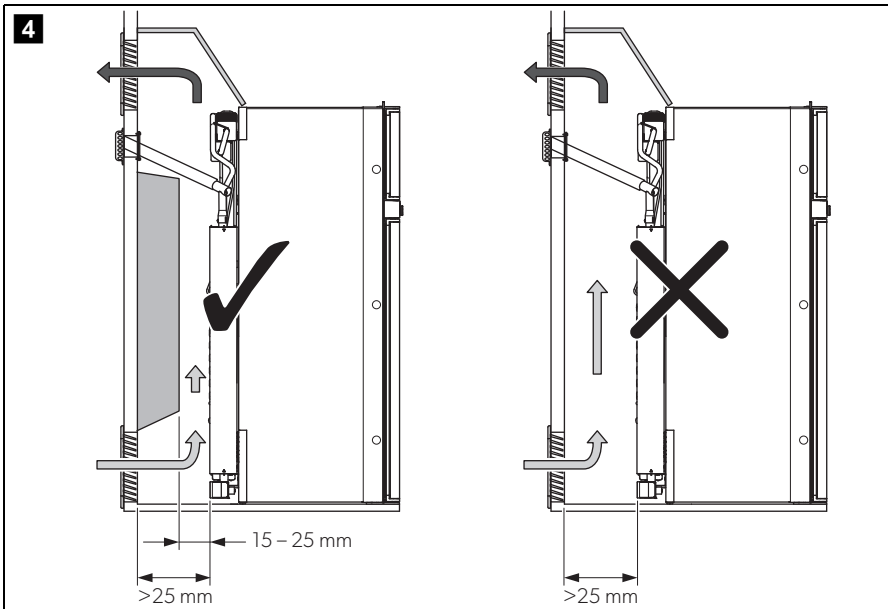

- The distance between the refrigerator and the rear wall must be at least 15 mm but no more than 25 mm.
- A distance of more than 25 mm between the refrigerator and rear wall leads to poor performance and increases the power consumption of the refrigerator. Reduce the space behind the refrigerator to create adequate air inlet and outlet ventilation (fig. **4**). Use a ventilation plate, for example, to do this.

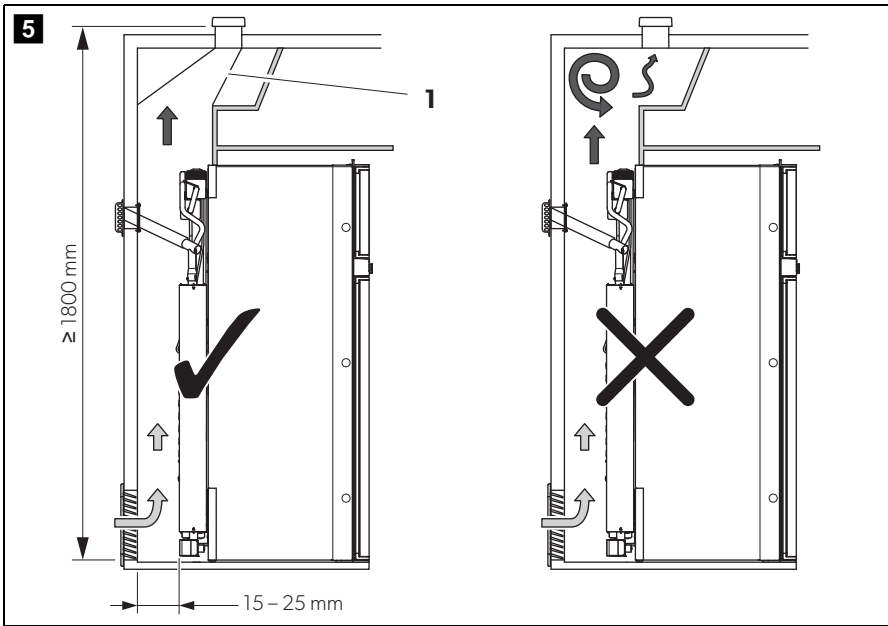

- If the minimum distance between the air inlet and outlet vents cannot be met, a roof vent must be installed instead of the air outlet vent.
 - The roof vent should be installed directly above the back of the refrigerator as far as this is possible. Use an air duct (fig. 5 1) if you need to install the roof vent offset; otherwise, heat will accumulate there.
 - The distance between the air inlet vent and the roof vent must be at least 1800 mm (fig. 5).

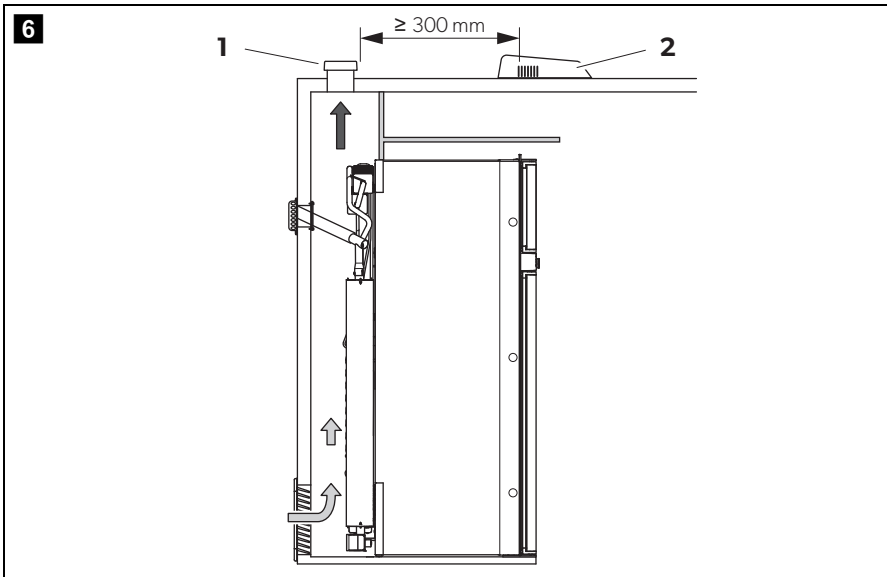

– If a roof air conditioner is provided, the distance between the roof vent (fig. 6 1) and the air outlet of the roof air conditioner (fig. 6 2) must be at least 300 mm.

- The refrigerator must not be installed at the side of the air inlet and outlet vents as this leads to poor performance and increases the power consumption of the refrigerator.
- The air inlet and outlet vents must not be covered by vehicle parts (such as an open door or by installing accessories such as bicycle racks) while operating.
- A separate flue duct must be installed under the air outlet vent, see chapter “Installing the flue duct” on page 19.
- Install the refrigerator so that it is protected from excessive heat, as this leads to poor performance and increases the power consumption of the refrigerator.
- The gas installation must comply with national and local regulations.
 - AS 5601.2 – Gas Installations
 - NZ 5601 – Gas Appliance Safety
- The refrigerator must be installed in a draft-proof location.

4.2 Installing the refrigerator in a draft-proof location



WARNING! Fire hazard!

- Do not use flammable materials such as silicone sealants, foam or similar for the draft-proof installation.
- Position the device so that no connection cable is damaged or pinched.
- Do not use multiple sockets or portable power adapters behind the device.

Gas-powered refrigerators in camper vans or mobile homes must be installed in a draft-free location. This means that the combustion air is not extracted from the interior and the exhaust fumes are prevented from directly entering the living space.

A suitable seal must be fitted between the rear panel of the refrigerator and the interior of the vehicle.

The manufacturer recommends using a flexible seal to ease removal and installation for maintenance purposes.

Select one of the three versions for draft-proof installation:

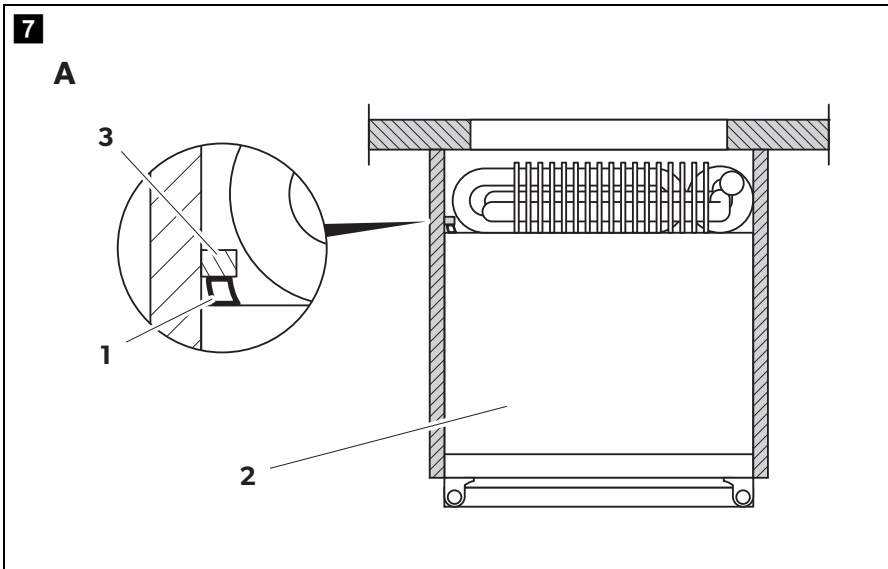

► **A:** The vehicle manufacturer affixes the seal to the front of a frame and pushes the refrigerator in front of this (fig. 7).

✓ The seal on the rear wall of the refrigerator seals.

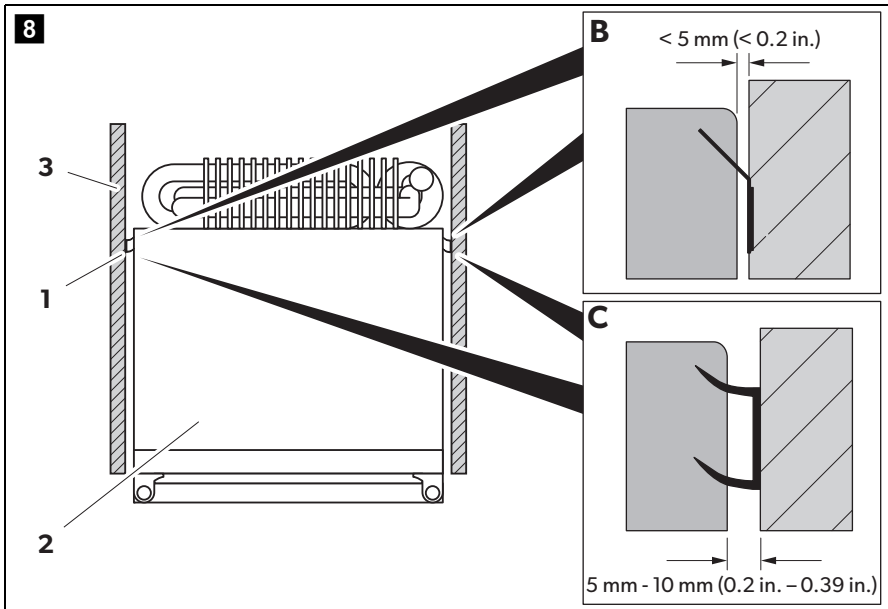

- ▶ **B:** For a side gap distance of up to 5 mm, glue the single lipped sealing (accessory) on the side of the cabinet behind the refrigerator (fig. **8 B**).
- ▶ Push the refrigerator against the cabinet.
- ✓ The space behind the refrigerator is sealed from the interior of the vehicle.
- ▶ **C:** For a side gap distance of 5 mm to 10 mm, glue the double lipped sealing (accessory) on the side of the cabinet behind the refrigerator (fig. **8 C**).
- ▶ Push the refrigerator against the cabinet.
- ✓ The space behind the refrigerator is sealed from the interior of the vehicle.

4.3 Making air inlet and outlet vents



NOTE

- Deviations from the inlet and outlet variations shown here must be approved by the manufacturer.
- At high ambient temperatures, the refrigerator can only provide its maximum cooling capacity if the optimum ventilation has been provided.

- Make an air inlet vent and an air outlet vent in the outer wall with the size of 249 mm x 490 mm. When doing so, observe the information, see chapter "Preparing the installation" on page 8.

If the ventilation grill of the air inlet vent cannot be installed flush with the floor of the niche, install an inlet vent in the floor. Any leaking gas can thus flow downwards.

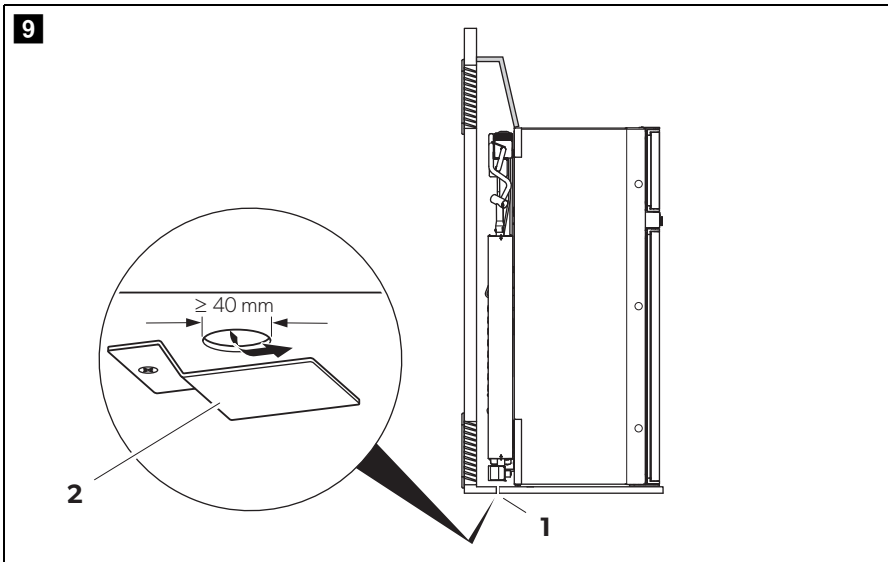

- Make an air inlet vent of at least $\varnothing 40$ mm in the floor (fig. **9** 1) behind the refrigerator near the gas burner.
- Shield the end of the opening with a deflector to prevent sludge or dirt from getting inside while driving (fig. **9** 2).

If you have to use a roof vent instead of the air outlet vent:

- Cut out a section in the roof. Refer to the roof vent instruction manual for the required dimensions. When doing so, observe the information in chapter "Preparing the installation" on page 8.

4.4 Installing the ventilation grill



NOTE

Use exclusively original Dometic ventilation grills to ensure safe operation.

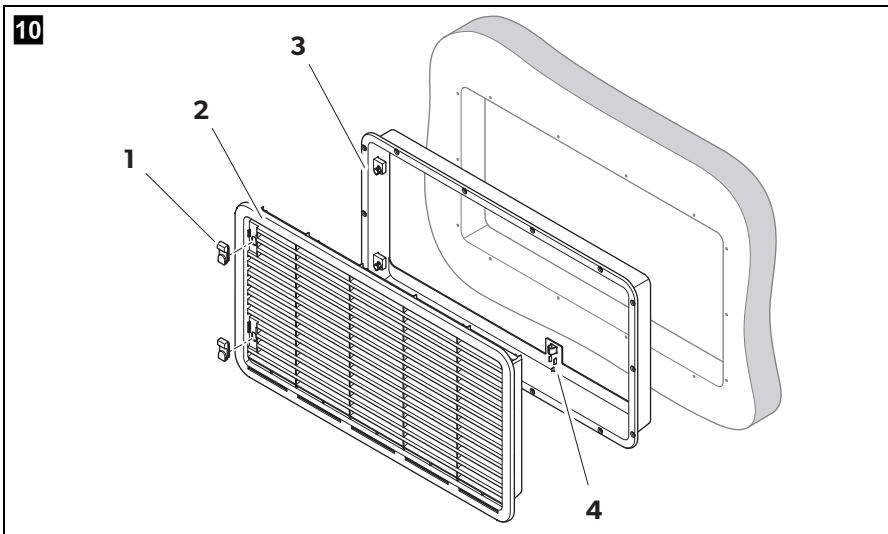

No. in fig. 10

Description

1	Slider
2	Ventilation grill
3	Installation frame
4	Fastening for condensation drain

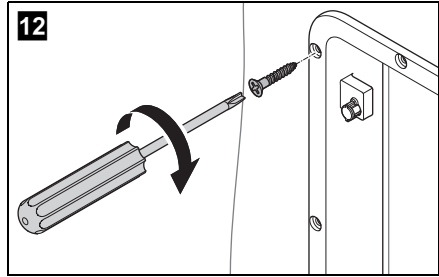
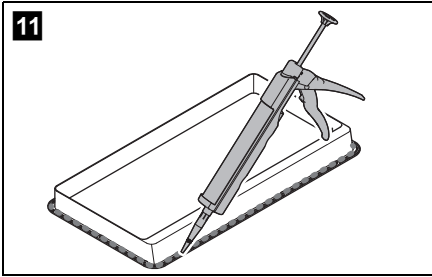

- Seal the installation frame to make the connection waterproof (fig. **11**).
- Insert the installation frame and screw it down tightly (fig. **12**). Use all the fixing holes for this.

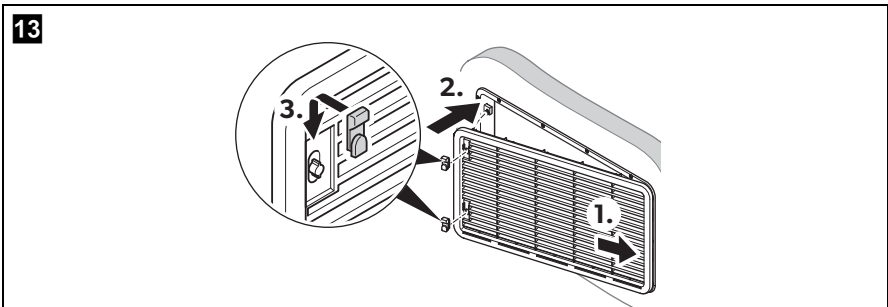

- Insert the ventilation grill as shown (fig. **13**).

4.5 Installing condensation drain



NOTE

- Condensation can form inside the refrigerator due to frequent door opening, incorrectly stored food or food that is stored when it is too warm.
- Condensation must be drained with a constant slope.

Install the condensation drain as follows:

Variant 1:

- Run the condensation hose from the refrigerator through an opening in the floor which goes outside under the vehicle.

Variant 2:

- Attach the condensation hose directly to the fastening intended for it on the ventilation grill (fig. 10 4, page 18).

Install the roof vent

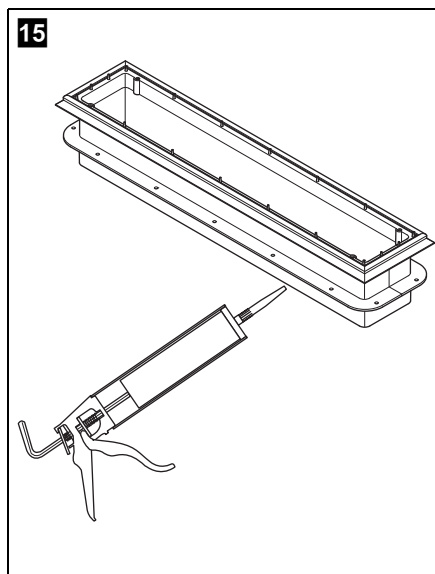
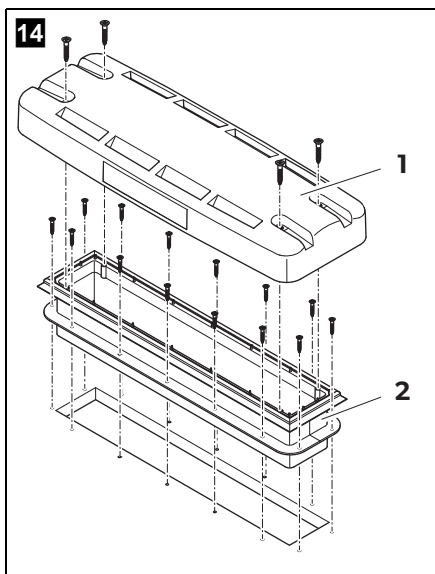

No. in fig. 14	Description
1	Hood
2	Installation frame

- Seal the installation frame to make the connection waterproof (fig. **15**).

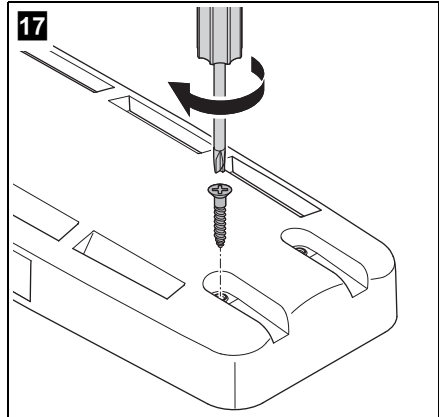
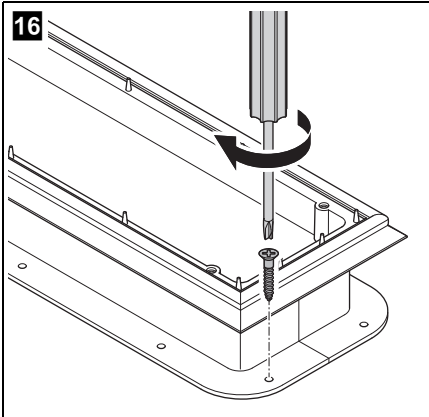

- Insert the installation frame and screw it down tightly (fig. **16**). Use all the fixing holes for this.
- Insert the hood and screw it down tightly (fig. **17**).

4.6 Installing the flue duct

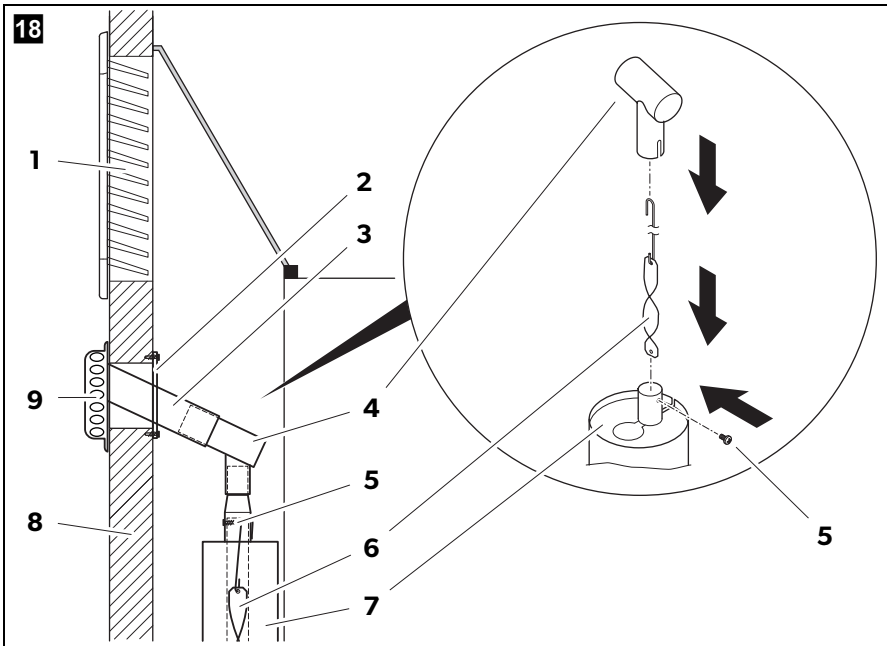

NOTE

- Install the Dometic gas flue kit 3776. Contact the customer service (see back page).
- Do not install an additional flue stack, as this leads to poor performance and increases the power consumption of the refrigerator.
- Mount the flue duct under the upper ventilation grille (fig. 19 1).

Install the flue duct as follows:

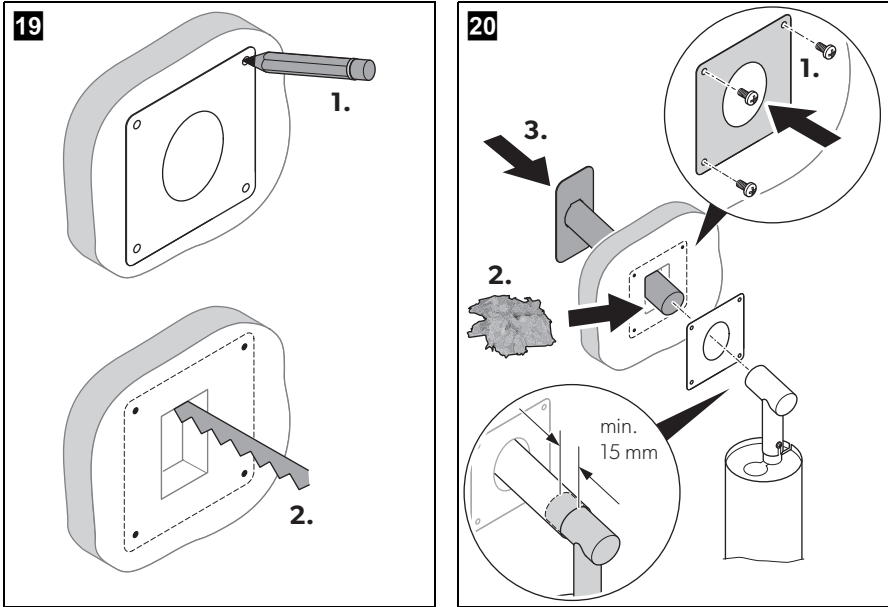

- ▶ Make a rectangular opening in the outer wall of the vehicle (fig. **19**).
 - The opening must be as wide as the flue pipe (fig. **18** 3).
 - The opening must be high enough that the flue pipe fits through at a 45° angle.
- ▶ Insert the coil (fig. **18** 7) in the flue pipe (fig. **18** 8) of the refrigerator.
- ▶ Place the T-piece (fig. **18** 4) on the adaptor (fig. **18** 5) and the flue pipe (fig. **18** 8) of the refrigerator.
- ▶ Direct the T-piece at an angle of 45° towards the rear wall.
- ▶ Attach the T-piece, adaptor and flue pipe with a screw (fig. **18** 6).
- ▶ Install the mounting plate (fig. **20**).
- ▶ Fill the opening with fire-resistant material, e.g. stone wool (fig. **20**).

**NOTE**

In some installation situations, it is possible that the flue pipe would extend too far out of the vehicle in its installed state. Shorten the flue pipe to the correct length if necessary.

- ▶ Slide the flue pipe at least 15 mm on the T-piece (fig. **20**).

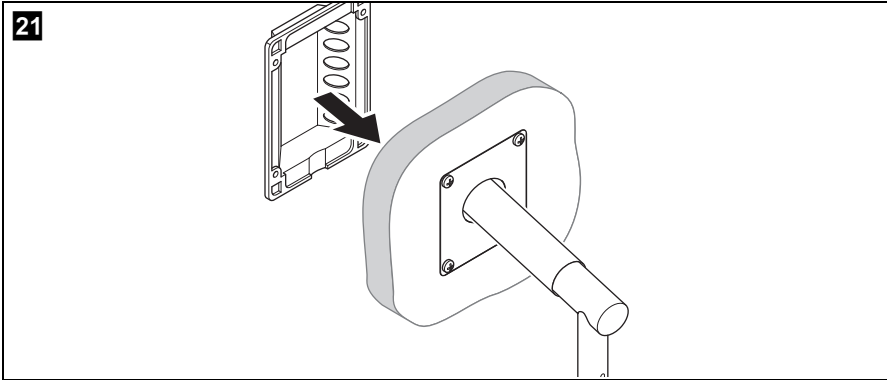

- ▶ Attach the cover for the flue stack outside on the vehicle (fig. **21**).

4.7 Securing the refrigerator



CAUTION!

Only screw through the receptacles provided, otherwise foamed components, such as cables, can be damaged.



NOTE

Attach the side walls or the attached strips so that the screws are tight, even when under increased loads (while driving).

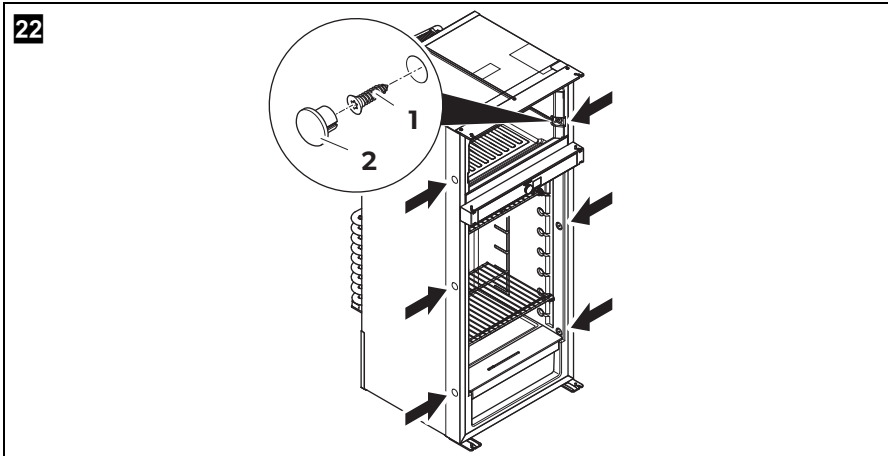

- Move the refrigerator into its final location.
- Fasten the six screws (fig. 22 1) through the six plastic washers in the sides of the refrigerator, and further into the wall.
- Put the caps (fig. 22 2) onto the screw heads.

5 Connecting the refrigerator

5.1 Connecting to the gas supply



NOTICE!

- This refrigerator may only be connected to the gas supply by a specialist in accordance with the applicable guidelines and standards.
- Use flexible gas piping to ensure that the installation remains in a tensionless state (not included in the scope of the delivery). A hose connection is **not** permitted.
- Use a metal-sealed screw connection.
- The gas filter (white) in the refrigerator gas connection must not be removed.
- Only use cylinders of propane or butane gas (not natural gas or city gas) with an approved pressure reduction valve and suitable head. Compare the pressure information on the type plate with the pressure information on the pressure regulator on the propane or butane gas cylinder.
- **Only** operate the refrigerator at the pressure shown on the type plate.
- **Only** operate the refrigerator with the type of gas shown on the type plate.
- Please note the pressures which are permitted in your country. Only use pressure controllers with a fixed setting which comply with the national regulations.

It must be possible to shut off the refrigerator from the gas line separately by means of a shut-off device. The shut-off device must be easily accessible.

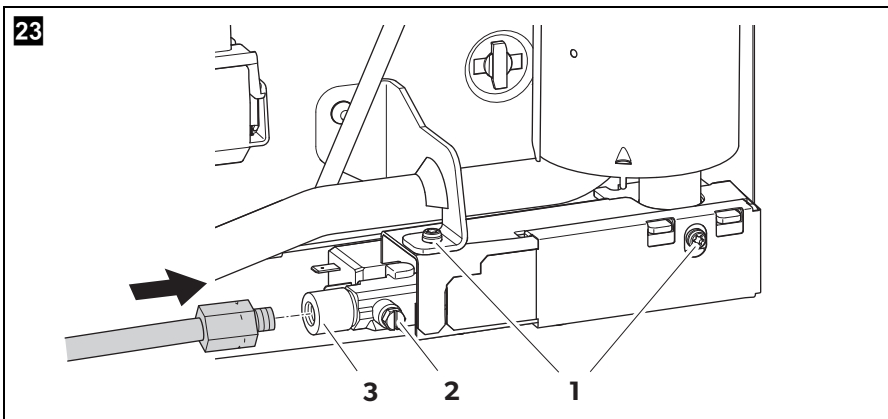

- Connect the refrigerator securely by hand to the gas supply (fig. 23):

Please note the following information:

Item in fig. 23	Description
1	Screw M4 (Torx TX20), Tightening torque: 2 Nm
2	Gas valve shut-off cock
3	Refrigerator gas connection: Rp1/8"-28

- Have a leak test and a flame test performed by an authorized specialist after professional installation.
Ensure you are issued with a certificate of inspection and hand this certificate to the end user for safekeeping.

5.2 Connecting to DC and AC

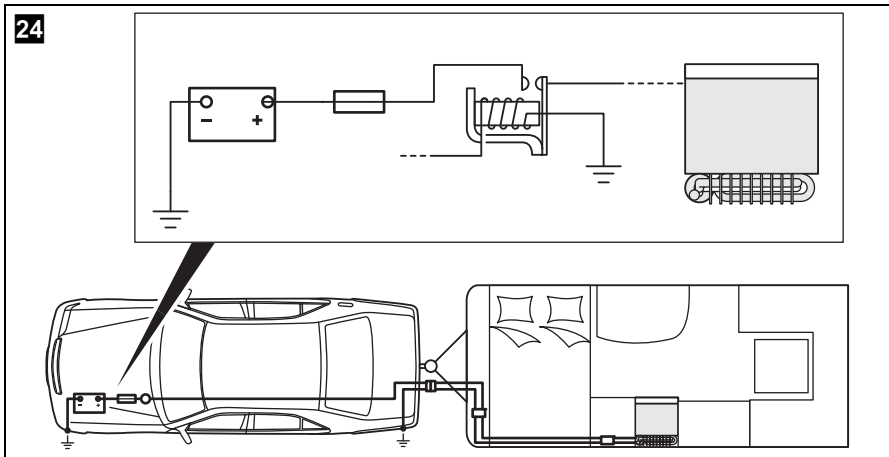

NOTICE!

- The electrical installation and repairs may only be performed by a specialist in accordance with the applicable regulations and standards.
- DC connection to the heating element must be made to the vehicle engine battery, connection only while engine is running (fig. 24).

**NOTE**

- The device plug must be easily accessible so that you can unplug it if required, thereby disconnecting the refrigerator from the power.
- The device plug must not be placed directly behind the ventilation grill in order to prevent the air circulation from being impaired and to protect the device plug from splashes of water.
- The device plug of the AC connection cable must not be cut off.
- The connection cables must be laid so that they do not come in contact with hot parts of the unit/burner or with sharp edges.
- Changes to the internal electrical installation or the connection of other electrical components (e.g. extra third party fans) to the internal wiring of the refrigerator will void any claims from the guarantee and product liability.
- The refrigerator has a CI bus interface and can be controlled through a compatible central vehicle display.

► Connect the refrigerator according to fig. **25**, page 29.

Item in fig. 25	Description
1	Fan 2 (if options module is not available)
2	Fan 1 (if options module is not available)
3	S+ (optional)
4	Heating element DC
5	12 V relay with 20 A fuse for heating cartridge
6	NTC 1: Refrigeration room NTC 2: Outside temperature (optional)
7	Gas valve
8	AC power supply
9	Heating element AC
10	Gas burner
11	Connection block
12	Lightning
13	Display
14	Heating frame
15	Fan 2 (if options module is available)
16	Fan 1 (if options module is available)
17	Options module
18	DC supply oven (if options module is available)
19	DC supply options module
20	CI-Bus Data
21	DC supply cable
22	DC terminal housing (front view) <ul style="list-style-type: none"> • AMP/TE Tyco: 180906 • CS Colombo: 63N025
23	DC supply cable electronics
24	DC supply cable heating element
25	DC internal supply cable, max. 1 A (options module, oven, fan)

DC power**WARNING! Fire hazard!**

- The supply line to the heating element must be protected with a 20 A fuse.
- The supply line to the electronics must be protected with a 2 A fuse.

**NOTICE!**

- The respective positive and negative supply lines of the DC connections for electronics (fig. 25 23) and heating element (fig. 25 24) may **not** be joined with one another and carried on a single wire. This can cause electrical interference or damage to electrical components.

Please note the following cable sizes:

- < 6 m (in the interior): at least 6 mm²
- > 6 m (in the interior): at least 10 mm²
- Connections electronics and heating element: 0.75 mm²
- Connections D+ and S+: 0.75 mm²
- Cable fed via drawbar (caravans only): 2.5 mm²
- ▶ Assemble your DC socket as follows (fig. 25):
 - Connect **A** and **C** to the positive pole of the battery.
 - Connect **D** and **F** to Connect D and F to ground.
 - Connect **B** to the D + signal.
The electronics of the refrigerator uses the signal D+ from the light system to detect the running engine. In automatic mode, the refrigerator selects the most favorable mode available. The refrigerator is only operated with direct current when the vehicle engine is running.
 - Connect **E** to the CI-BUS.
- ▶ Connect **3** with the S+ signal (optional).
- ▶ Protect the supply line **A** with a 2 A fuse in the power distribution box of the vehicle.
- ▶ Protect supply line **C** with a 20 A fuse in the power distribution box of the vehicle.
- ▶ Run the supply line **C** via an ignition-controlled relay.
This prevents the battery from completely discharging if the engine is switched off accidentally.

AC power

- Connect the refrigerator to an AC socket using the device plug.

5.3 Alternative connection methods for DC power supply

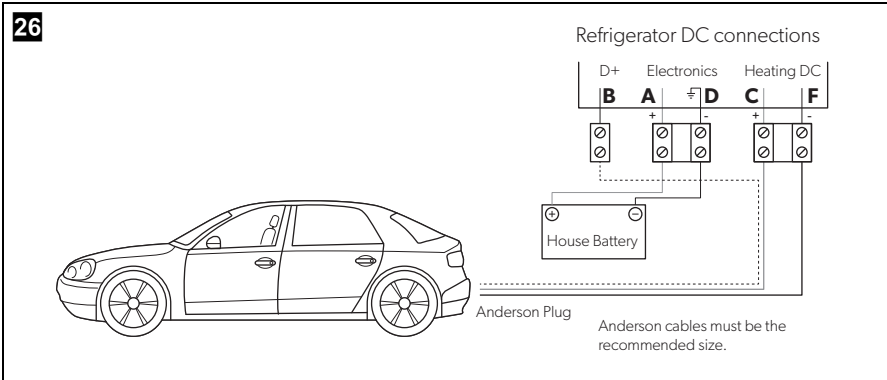

Connection to suit motor home or caravan with the D+ wire connected to the vehicle alternator or ignition switch.

No house battery recharging from the vehicle.

The D+ connection is taken to the vehicle alternator.

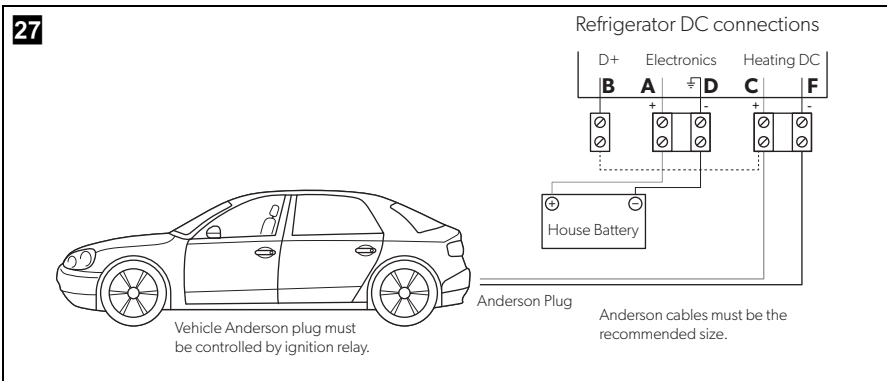

Anderson plug controlled by vehicle relay to the ignition switch. Power can only be supplied if the engine is running.

No house battery recharging from the vehicle.

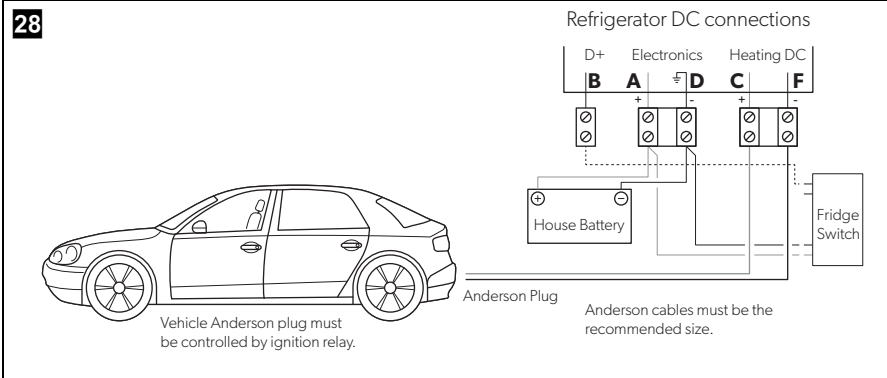

Using a fridge movement switch to add 12 V $\overline{=}$ to the D+ connection wire, only when the vehicle is moving.

No house battery recharging from the vehicle.

The D+ is turned on and off via an optional fridge movement switch.

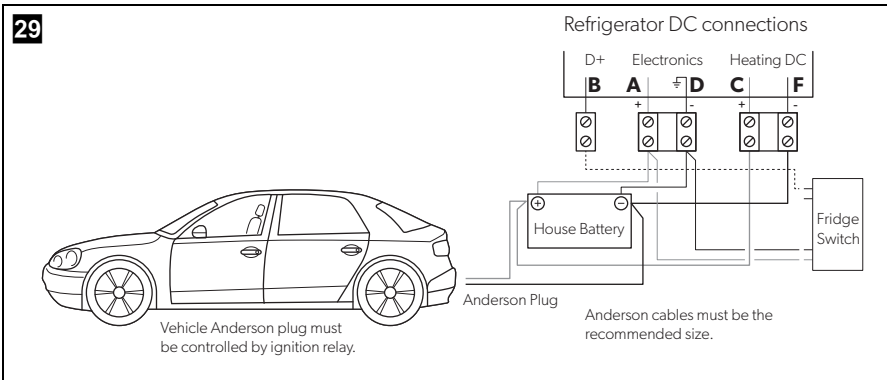

Using a fridge movement switch to add 12 V $\overline{=}$ to the D+ connection wire, only when the vehicle is moving. The Anderson plug connection must keep the house battery fully charged.

House battery recharged by vehicle.

The D+ is turned on and off via an optional fridge movement switch.

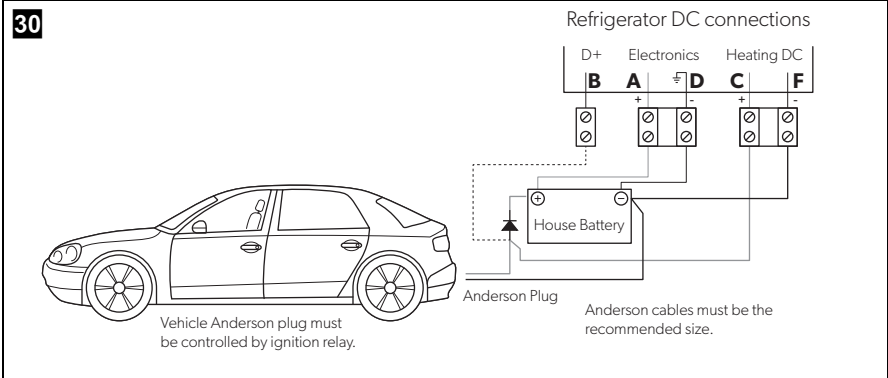



Anderson plug recharging the house battery via a power diode. The D+ wire can only get a 12 V signal when the battery is being charged.

House battery recharged by vehicle.

The D+ is turned on and off by the vehicle starting and stopping.

6 Technical data

	RMD10.5(T)	RMD10.5X(T)
Connection voltage:	230 V~ /50 Hz 12 V===	
Capacity		
Gross capacity:	153 l	177 l
Refrigerator compartment:	124 l	142 l
Ice compartment:	29 l	35 l
Total net capacity:	147 l	171 l
Power consumption:	250 W (230 V~) 170 W (12 V===)	
Energy consumption:	4.2 kWh/24 h (230 V~)	
Gas consumption:	522 g/24 h	
Gas connecting pressure:	2.75 kPa	
Climate class:	T	
Batteries (optional):	12 x AA 1.5 V	
Dimensions H x W x D:	fig. 1 , page 9	
Weight:	43.9 kg	45.5 kg
Inspection/certification:	 	

Mobile living made easy.



dometic.com

**YOUR LOCAL
DEALER**

dometic.com/dealer

**YOUR LOCAL
SUPPORT**

dometic.com/contact

**YOUR LOCAL
SALES OFFICE**

dometic.com/sales-offices

A complete list of Dometic companies, which comprise the Dometic Group, can be found in the public filings of:
DOMETIC GROUP AB Hemvärnsgatan 15 SE-17154 Solna Sweden