

**DRAPER**<sup>®</sup>

230V 150mm & 200mm

# BENCH GRINDER

05095 & 05097



**UK**  
**CA** **CE**

These instructions accompanying the product are the original instructions. This document is part of the product, keep it for the life of the product passing it on to any subsequent holder of the product. Read all these instructions before assembling, operating or maintaining this product.

This manual has been compiled by Draper Tools describing the purpose for which the product has been designed, and contains all the necessary information to ensure its correct and safe use. By following all the general safety instructions contained in this manual, it will ensure both product and operator safety, together with longer life of the product itself.

All photographs and drawings in this manual are supplied by Draper Tools to help illustrate the operation of the product.

Whilst every effort has been made to ensure the accuracy of information contained in this manual, the Draper Tools policy of continuous improvement determines the right to make modifications without prior warning.

# 1. INTRODUCTION

## 1.1 SCOPE

This bench grinder uses abrasive discs to grind masonry, metal and other materials.

Part of our core range, this product is suitable for enthusiasts and tradespersons alike. Any application other than that it was intended for, is considered misuse.

This product is not a toy and must not be used by children or any person with reduced physical, sensory or mental capabilities or lack of experience and knowledge, or people unfamiliar with these instructions.

Local regulations may restrict the age of the operator.

## 1.2 UNDERSTANDING THIS MANUALS SAFETY CONTENT:

 **Warning!** – Information that draws attention to the risk of injury or death.

**Caution!** – Information that draws attention to the risk of damage to the product or surroundings.

## 1.3 EXPLANATION OF SYMBOLS



Warning!  
Read the instruction manual.



Wear face mask and suitable eye/face protection.



Capacity (Watts).



Grinding wheel diameter.



Grinding wheel thickness.



Grinding wheel bore size.



Revolutions per minute.



Grinding wheel grit.



Machine weight.



WEEE –  
Waste Electrical & Electronic Equipment.  
Do not dispose of Waste Electrical & Electronic Equipment in with domestic rubbish.



Continuous A-Weighted Sound Pressure Level (*example shown*).



For indoor use only.  
Do not expose to rain.



Class 1 appliance  
(Must be earthed).



UK Conformity Assessed.



European conformity.

# 2. SPECIFICATION

## 2.1 SPECIFICATION

Stock No. .... 05095

Part No. .... GD625L

Rated voltage ..... 230V~50Hz

Rated input ..... 370W(S2)

Revolutions per minute (no load) ..... 2,850

Wheel dimension:

Maximum diameter ..... 150mm

Maximum thickness ..... 20mm

Bore diameter ..... 12.7mm

Abrasive Wheel (supplied):

Fine ..... 60grit

Coarse ..... 36grit

Sound Pressure Level ..... 82dB(A)

Sound Power Level ..... 92dB(A)

Vibration Level ..... <2.5m/s<sup>2</sup>

Weight (Gross/Net) ..... 9.0/10.5kg

Stock no. .... 05097

Part no. .... GD825L

Rated voltage ..... 230V~50Hz

Rated input ..... 550W(S2)

Revolutions per minute (no load) ..... 2,850

Wheel dimension:

Maximum diameter ..... 200mm

Maximum thickness.....	25mm
Bore diameter.....	12.7mm
Abrasive Wheel (supplied):	
Fine.....	60grit
Coarse.....	36grit
Sound Pressure Level.....	86dB(A)
Sound Power Level .....	95.7dB(A)
Vibration Level .....	<2.5m/s2
Weight (Gross/Net).....	19.0/20.0kg

### 3. HEALTH AND SAFETY INFORMATION

#### 3.1 GENERAL SAFETY INSTRUCTIONS FOR POWER TOOL USE

 **Warning! Read all safety warnings, instructions, illustrations and specifications provided with this power tool.** Failure to follow all instructions listed below may result in electric shock, fire and/or serious injury.

**Save all warnings and instructions for future reference.**

The term “power tools” in the warnings refers to your mains-operated (corded) power tool or battery-operated (cordless) power tool.

##### 1) Work area safety

- a) **Keep work area clean and well lit.** Cluttered or dark areas invite accidents.
- b) **Do not operate power tools in explosive atmospheres, such as in the presence of flammable liquids, gases or dust.** Power tools create sparks which may ignite the dust or fumes.
- c) **Keep children and bystanders away while operating a power tool.** Distractions can cause you to lose control.

##### 2) Electrical safety

- a) **Power tool plugs must match the outlet. Never modify the plug in any way. Do not use any adapter plugs with earthed (grounded) power tools.** Unmodified plugs and matching outlets will reduce risk of electric shock.
- b) **Avoid body contact with earthed or grounded surfaces, such as pipes, radiators, ranges and refrigerators.** There is an increased risk of electric shock if your body is earthed or grounded.
- c) **Do not expose power tools to rain or wet conditions.** Water entering a power tool will increase the risk of electric shock.
- d) **Do not abuse the cord. Never use the cord for carrying, pulling or unplugging the power tool. Keep cord away from heat, oil, sharp edges or moving parts.** Damaged or entangled

cords increase the risk of electric shock.

- e) **When operating a power tool outdoors, use an extension cord suitable for outdoor use.** Use of a cord suitable for outdoor use reduces the risk of electric shock.
- f) **If operating a power tool in a damp location is unavoidable, use a residual current device (RCD) protected supply.** Use of an RCD reduces the risk of electric shock.

##### 3) Personal safety

- a) **Stay alert, watch what you are doing and use common sense when operating a power tool. Do not use a power tool while you are tired or under the influence of drugs, alcohol or medication.** A moment of inattention while operating power tools may result in serious personal injury.
- b) **Use personal protective equipment Always wear eye protection.** Protective equipment such as a dust mask, non-skid safety shoes, hard hat or hearing protection use for appropriate conditions will reduce personal injuries.
- c) **Prevent unintentional starting. Ensure the switch is in the off-position before connecting to power source and/or battery pack, picking up or carrying the tool.** Carrying power tools with your finger on the switch or energising power tools that have the switch on invites accidents.
- d) **Remove any adjusting key or wrench before turning the power tool on.** A wrench or a key left attached to a rotating part of the power tool may result in personal injury.
- e) **Do not overreach. Keep proper footing and balance at all times.** This enables better control of the power tool in unexpected situations.
- f) **Dress properly. Do not wear loose clothing or jewellery. Keep your hair and clothing away from moving parts.** Loose clothes, jewellery or long hair can be caught in moving parts.
- g) **If devices are provided for the connection of dust extraction and collection facilities, ensure these are connected and properly used.** Use of dust collection can reduce dust-related hazards.
- h) **Do not let familiarity gained from frequent use of tools allow you to become complacent and ignore tool safety principles.** A careless action can cause severe injury within a fraction of a second.

##### 4) Power tool use and care

- a) **Do not force the power tool. Use the correct power tool for your application.** The correct power tool will do the job better and safer at the rate for which it was designed.
- b) **Do not use the power tool if the switch does not turn it on and off.** Any power tool that

cannot be controlled with the switch is dangerous and must be repaired.

- c) **Disconnect the plug from the power source and/or remove the battery pack, if detachable, from the power tool before making any adjustments, changing accessories, or storing power tools.** Such preventive safety measures reduce the risk of starting the power tool accidentally.
- d) **Store idle power tools out of the reach of children and do not allow persons unfamiliar with the power tool or these instructions to operate the power tool.** Power tools are dangerous in the hands of untrained users.
- e) **Maintain power tools and accessories. Check for misalignment or binding of moving parts, breakage of parts and any other condition that may affect the power tool's operation. If damaged, have the power tool repaired before use.** Many accidents are caused by poorly maintained power tools.
- f) **Keep cutting tools sharp and clean.** Properly maintained cutting tools with sharp cutting edges are less likely to bind and are easier to control.
- g) **Use the power tool, accessories and tool bits etc. in accordance with these instructions, taking into account the working conditions and the work to be performed.** Use of the power tool for operations different from those intended could result in a hazardous situation.
- h) **Keep handles and grasping surfaces dry, clean and free from oil and grease.** Slippery handles and grasping surfaces do not allow for safe handling and control of the tool in unexpected situations.

## 5) Service

- a) **Have your power tool serviced by a qualified repair person using only identical replacements parts.** This will ensure that the safety of the power tool is maintained.

## 3.2 SPECIFIC SAFETY INSTRUCTION FOR BENCH GRINDERS

### Warning!

- Check that speed marked on the wheel is equal to or greater than the rated speed of the grinder.
- Ensure that the wheel dimensions are compatible with the grinder.
- Abrasive wheels shall be stored and handled with care in accordance with manufacturer's instructions.
- Inspect the grinding wheel before use, do not use chipped, cracked or otherwise defective products.
- Ensure that mounted wheels and points are fitted in accordance with the manufacturer's instructions.
- Ensure that blotters are used when they are provided with the bonded abrasive product and when they are

required.

- Ensure that the abrasive product is correctly mounted and tightened before use and run the tool at no-load speed for 30 seconds in a safe position – stop immediately if there is considerable vibration or if other defects are detected. If this condition occurs, check the machine to determine the cause.
- Never use the tool without such a guard.
- Do not use separate reducing bushings or adaptors to adapt large hole abrasive wheels.
- For tools intended to be fitted with threaded hole wheel, ensure that the thread in the wheel is long enough to accept the spindle length.
- Check that the work piece is properly supported.
- Do not use cutting wheel for side grinding.
- Ensure that sparks resulting from use do not create a hazard – e.g. do not hit persons or ignite flammable substances.
- Ensure that ventilation openings are kept clear when working in dusty conditions. If it should become necessary to clear dust, first disconnect the tool from the mains supply (use non metallic objects) and avoid damaging internal parts.
- Always use eye and ear protection.
- Personal protective equipment such as dust mask, gloves, helmet and apron should be worn.
- The wheel continues to rotate after the tool is switched off.
- Stay alert. Watch what you are doing. Use common sense. Do not operate tool when you are tired.

**Wear proper clothing.** Do not wear loose clothing, neckties or jewellery (ring, wristwatches etc.) to catch in moving parts. Non-slip footwear is recommended. Wear protective covering to contain long hair. Roll long sleeves above the elbow.

**Use safety goggles (Head protection).** Wear goggles approved to the relevant standards at all times. Normal spectacles only have impact resistant lenses, they are **NOT** safety glasses.

Also, use face or dust mask if application is dusty and ear protectors during all operations.

**Sound levels.** Some types of machines may have high sound levels when working. In such cases ear protection must be worn.

**Vibration levels.** Hand held power tools produce different vibration levels. You should always refer to the specifications and the relevant Health and Safety guidelines.

**Dust extraction.** If your tool is fitted with a dust extraction facility, always ensure that it is connected and being used with a dust extractor. Vacuum cleaners can be used if suitable for the material being extracted.

**Check damaged parts.** Before further use of the tool, a guard or other part that is damaged should be carefully checked to determine that it will operate properly and

perform its intended function;

- Check for alignment of moving parts, free running of moving parts, breakage of parts, mounting and any other conditions that may affect its operation. A guard or other part that is damaged should be properly repaired or replaced by an authorised service centre unless otherwise indicated in this instruction manual.
- Have defective switches replaced by an authorised service centre. **Do not use the tool if the switch does not turn it on and off.**

**Have your tool repaired by a qualified person.** This electric tool is in accordance with the relevant safety requirements. Repairs should only be carried out by qualified persons using original spare parts, otherwise this may result in considerable danger to the user.

### 3.3 SAFETY RECOMMENDATIONS FOR THE CORRECT USE OF ABRASIVE PRODUCTS

**General.** Bonded abrasive products are breakable and shall therefore be handled with utmost care. The use of damaged or improperly mounted or used abrasive products is dangerous and can cause serious injuries.

**Delivery, handling and storage.** Abrasive products must be handled and transported with care. Abrasive products must be stored in such a manner that they are not subjected to mechanical damaged and harmful environmental influences.

**Selection of the abrasive product.** Information on the label or the abrasive product stating restrictions of use, safety indications or any other instructions must be followed. In case of doubt concerning the selection of abrasive products, the user shall request information from the manufacturer or supplier.

**Visual inspection and ring test.** Abrasive products must be subjected to a visual inspection as received before mounting. In addition, a ring test shall be executed for vitrified wheels with  $D > 80\text{mm}$ . Damaged abrasive products shall be destroyed.

**Mounting before starting and information for grinding.** The mounting of abrasive products shall be carried out according to the instructions provided by both the wheel and the machine manufacturer. Mounting of abrasive products must be carried out by a qualified trained person. After initial mounting, the wheel must be test run for a reasonable time – the specified maximum operating speed of the wheel shall not be exceeded.

**Further information.** The following instructions must be observed, supplementary to the information contained in the instruction for use of the grinding machine:

- Observance of the user's information from the grinding machine manufacturer.
- Safety devices shall be mounting to the machine and shall be secured.
- No grinding operations without protection by safety devices.

- Use of personal protective equipment according to the type of machine and type of application, e.g. eye and face protection, ear protection, respiratory protective devices, protective footwear, protective gloves and other protective clothing.
- Only grinding operations for which the abrasive product is suitable shall be carried out (taking into account restrictions of use, safety indications or other information).
- Jamming of the hand-held grinding machine shall be prevented. In the case of cutting-off with hand-held grinding machines, the abrasive product shall be placed in the cutting gap in a straight position.
- Before placing the hand-held grinding machine on the workbench or on the floor it shall be turned off and it shall be ensured that the abrasive product has stopped.

### 3.4 SAFETY RECOMMENDATIONS FOR THE CORRECT USE OF SUPERABRASIVES

**General.** Superabrasives are breakable and shall therefore be handled with utmost care! The use of damaged or improperly mounted or used superabrasives is dangerous and can cause serious injuries.

**Delivery, handling and storage.** Superabrasives shall be handled and transported with care. Superabrasives shall be stored in such a manner that they are not subjected to mechanical damages and harmful environmental influences.

**Selection of superabrasives.** Information on the label or the superabrasive as well as restrictions of use, safety indications or any other instruction shall be followed. In case of doubt concerning the selection of superabrasives, the user shall request information from the manufacturer or supplier.

**Visual inspection and ring test.** Superabrasives shall be subjected to a visual inspection as received before mounting. In a addition, a ring test shall be executed for superabrasives with vitrified core and abrasive section and  $D > 80\text{mm}$ . Damaged superabrasives shall not be used.

**Mounting, before starting and information for grinding.** The mounting of superabrasive shall be carried out according to the instructions provided by both, the superabrasive and the machine manufacturer. Special attention shall be drawn to the fact that mounting of superabrasives is to be carried out by a qualified trained person. Each time after mounting, the superabrasive shall be test run for a reasonable time – the specified maximum operating speed of the superabrasive shall not be exceeded.

**Further information.** The following instructions shall be observed, supplementary to the information of the grinding machine:

- Observance of the user's information of grinding machine manufacturer.
- Before starting, safety devices shall be mounted to the machine.
- No grinding operations without protection by safety devices.
- Use of personal protective equipment according to the type of machine and type of application, e.g. eye and face protection, ear protection, respiratory protection devices, protective footwear, protective gloves and other protective clothing.
- Only grinding operations for which the superabrasive is suitable shall be carried out (taking into account restrictions of use, safety indications or other information).
- In the case of cutting-off with hand-held grinding machines, the superabrasive shall be placed in the cutting gap in a straight position. Jamming of the hand-held grinding machine shall be prevented.
- Before placing the hand-held grinding machine on the workbench or on the floor it shall be turned off and it shall be ensured that the abrasive product has stopped.

### 3.5 RESIDUAL RISK

**Important:** Although the safety instructions and operating manuals for our tools contain extensive instructions of safe working with power tools, every power tool involves a certain residual risk which can not be completely excluded by safety mechanisms. Power tools must therefore always be operated with caution!

### 3.6 CONNECTION TO THE POWER SUPPLY

**Caution:** Risk of electric shock. Do not open.

This appliance is supplied with an approved plug and cable for your safety. The value of the fuse fitted is marked on the pin face of the plug. Should the fuse need replacing, ensure the substitute is of the correct rating, approved to BS1362 and ASTA or BS Kite marked.

ASTA 

BSI 

Make sure the power supply information on the machine's rating plate are compatible with the power supply you intend to connect it to.

If a replacement plug is to be fitted this must be carried out by a qualified electrician.

The damaged or incomplete plug, when cut from the cable shall be disabled to prevent connection to a live electrical outlet.

This appliance is Class I<sup>†</sup> and is designed for connection to a power supply matching that detailed on the rating label and compatible with the plug fitted.

If an extension lead is required, use an approved and compatible lead rated for this appliance. Follow all the

instruction supplied with the extension lead.

†Earthed:  This product requires an earth connection to protect against electric shock from accessible conductive parts in the event of a failure of the basic insulation.

**Important:** If using an extension lead, follow the instructions that came with your lead regarding maximum load while cable is wound. If in doubt, ensure that the entire cable is unwound. Using a coiled extension lead will generate heat which could melt the lead and cause a fire.

## 4. UNPACKING AND CHECKING

### 4.1 PACKAGING

Carefully remove the product from the packaging and examine it for any sign of damage. Check contents against the parts shown in Fig A. If any part is damaged or missing, please contact the Draper Help Line (see back page). Do not attempt to use the product!

The packaging material should be retained during the warranty period, in case the product needs to be returned for repair.

#### **Warning!**

- Some of the packaging materials may be harmful to children. Do not leave any of these materials in reach of children.
- If any of the packaging is to be thrown away, make sure they are disposed of correctly, according to local regulations.

## 5. IDENTIFICATION – FIG.A

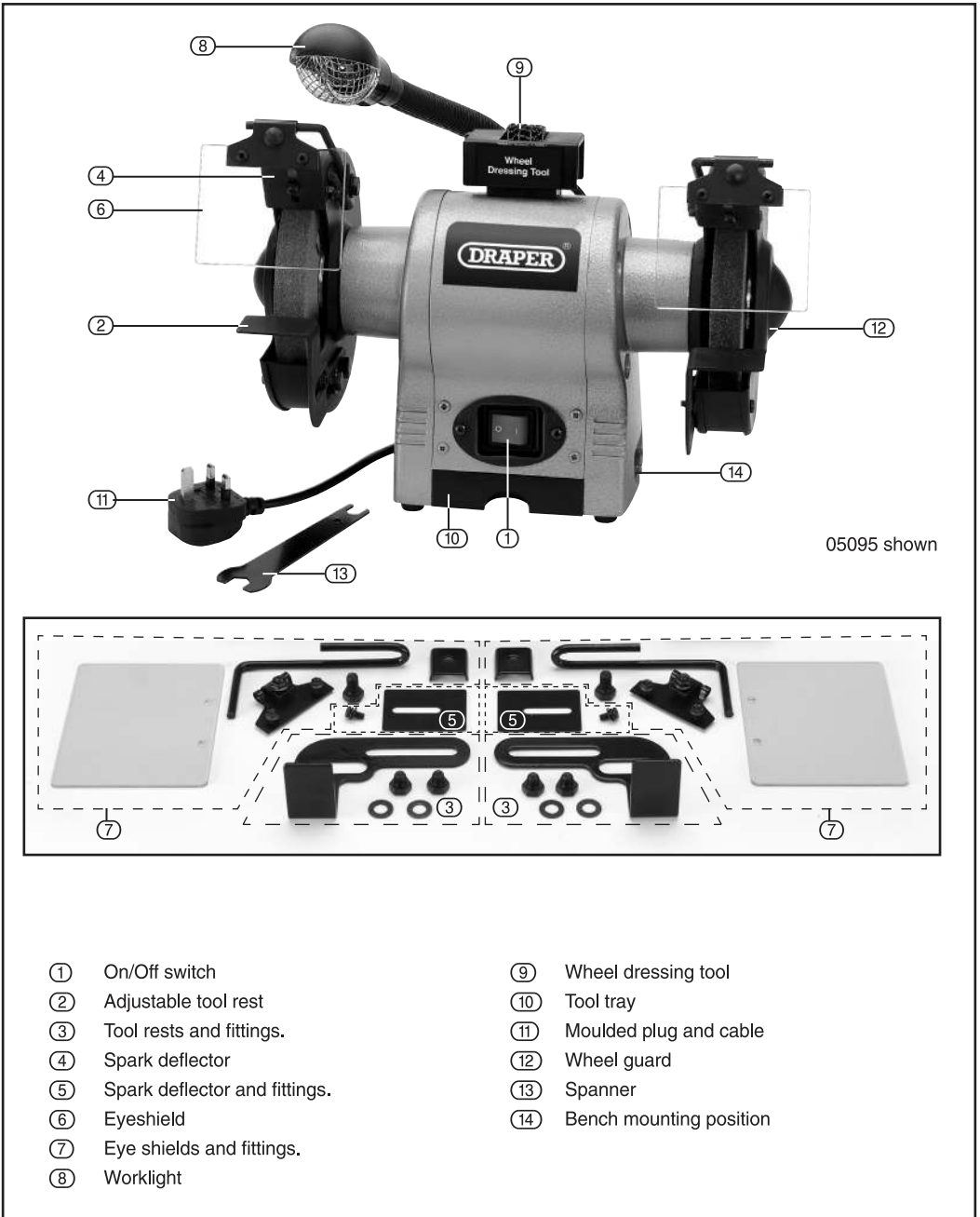

FIG.A

**Note:** For details of our full range of accessories and consumables, please visit [drapertools.com](http://drapertools.com)

## 6. ASSEMBLING THE WELDER

**Note:** Remove the plug from the power source before carrying out adjustment, servicing or maintenance.

### 6.1 SPARK DEFLECTORS - FIG.1

Fit both the spark deflectors (4) to the wheel guards using the screws provided.

- Adjust the spark arrestor frequently so as to compensate for wear of the wheel, keep the distance between the spark arrestor and wheel as small as possible and not greater than 2mm.



FIG. 1

### 6.2 TOOL RESTS - FIG.2

Fit both the tool rests (2) to the inner edge of the wheel guards using the locking nuts (2.1) provided. Adjust them so there is approximately 1.5mm between the grinding wheel face and the tool rest.

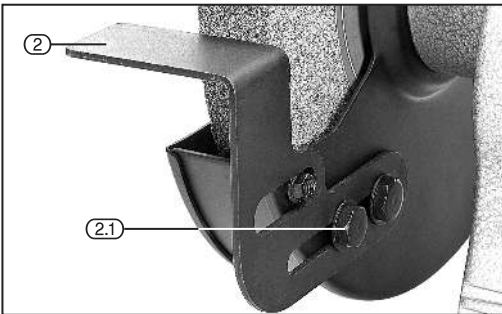

FIG. 2

**Note:** Ensure the tool rest sits over the guard securing bolt.

### 6.3 EYESHIELDS - FIGS.3 - 4

Assemble the clear plastic shield (6) to the metal plate (7.2) using the nuts and screws provided. Clamp (7.1) to the rod and fix the assembled shield to the wheel guard.

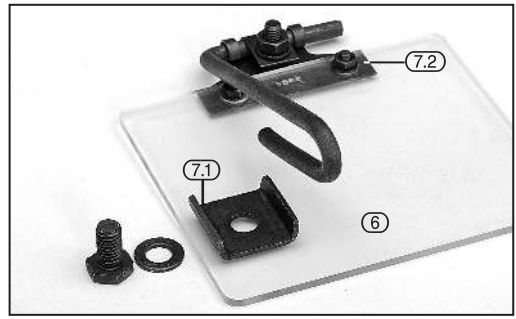

FIG. 3

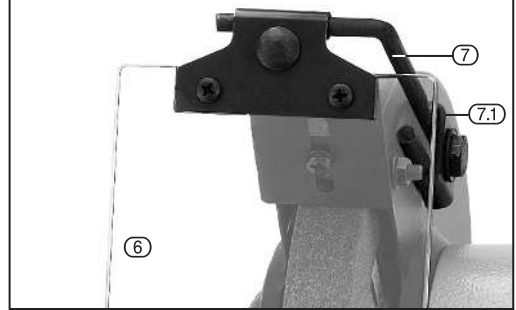

FIG. 4

Select the required position and tighten all the fixings.

**Note:** Do not overtighten the fixings holding the shield as this may cause it to crack. Never attempt to use the bench grinder with the eyeshields cracked, missing or incorrectly positioned. The eyeshield must remain between the user and abrasive wheel.

### 6.4 BENCH MOUNTING YOUR GRINDER - FIG.5

Securely bolt the bench grinder to a workbench or other secure surface through the two points in the base (fixings are not supplied). Ensure there is enough clear space around the grinder to accommodate large items which may be ground (garden tools, for example).

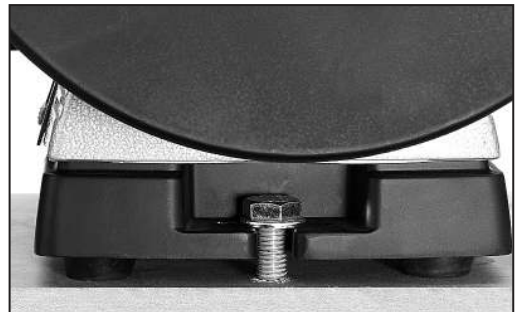

FIG. 5

To reduce any vibration, mount the grinder on a vibration absorption mat, Draper Stock No.30743.

## 6.5 REPLACING THE GRINDING WHEELS - FIG 5

- Do not use damaged grinding wheels.
- Switch the grinder off and disconnect the power supply. Remove the screws and nuts holding the wheel guard and remove the cover. Hold the other wheel by hand and remove the locking nut and flange. Slide off the old grinding wheel.



FIG. 6

- Only use grinding wheels recommended by the manufacturer with a marked speed equal to or greater than the speed marked on the nameplate of the tool. The maximum dimensions shall be no greater than:

- 150mm diameter, 19mm thickness with a corresponding bore size of 12.7mm.
- 200mm diameter, 25mm thickness with a corresponding bore size of 12.7mm.
- Abrasive products shall be subjected to a visual inspection as received before mounting.
- In addition, a ring test shall be executed for vitrified wheels with a diameter over 80mm.
- Damaged abrasive products shall be destroyed.

**Note:** The left hand grinding wheel locking nut has a left handed thread. When fitting a new grinding wheel, always check that the stated maximum RPM on the wheel exceeds the RPM for the bench grinder. Also, inspect the new wheel for any damage, such as flaws or cracks. If the wheel appears satisfactory, fit it to the grinder.

Replace the flange and locking nut securely. Do not overtighten to avoid damage to the wheel. Reassemble the guard fully prior to carrying out testing.

- Test run the wheel for a reasonable time each time after mounting.
- The specified maximum operating speed of the wheel shall not be exceeded.
- A bench grinder is designed for operating hand grinding operations only, such as sharpening drill bits, chisels and screwdrivers or removing excess metal from workpieces.
- A coarse grit abrasive wheel could be used for rough

metals, to remove large amounts of metal or where a smooth finish is not important.

- A fine grit abrasive wheel could be used for sharpening tools or grinding close to size. A fine grit wheel removes metal more slowly and therefore gives the work piece a smooth finish and does not generate enough heat to anneal the cutting edges.
- Check that there is a 1.5mm clearance between the tool rests and the surface of the accessory. Adjust as necessary. Recheck the gap between the spark deflectors and the surface of the grinding wheels. These should also be 1.5mm. Adjust as necessary.
- Check that the eyeshields have been secured in the correct position and that the grinding wheel lock nuts are tight.
- When grinding, always keep the work piece moving across the face of the wheel. Grinding against the same part of the wheel will cause uneven wear of the wheel face.
- When necessary, dress the abrasive wheels using a wheel dressing tool. After dressing, adjust the tool rests and spark deflectors as necessary to maintain a 1.5mm clearance from the wheel.

## 7. OPERATION AND USE GRINDER

- Ensure that the item to be ground is comfortably and securely held.
- Present the workpiece smoothly on to the grinding wheel face with a light and even pressure.
- Grind against the edge of the workpiece to avoid burrs.
- Never grind on the sides of the wheels.
- Best results are achieved if the grinder is allowed to rotate at its maximum speed. Excess pressure from the workpiece can damage the wheel and overload the motor.
- Check grinding wheels regularly for wear or damage. Replace wheels that are worn more than 25%. Damaged wheels should be discarded immediately as they are dangerous and can cause the grinder to vibrate.
- After grinding fine edge tools, they should be honed by hand on a fine slip stone.

## 8. MAINTENANCE

### 8.2 MAINTENANCE

Regular inspection and cleaning reduces the necessity for maintenance operations and will keep your tool in good working condition.

The bench grinder must be correctly ventilated during tool operation. Avoid blocking the air inlets and vacuum the ventilation slots regularly.

Do not use solvents or fuels to clean the product. When not in use, store the product in a safe, dry place.

## 9. WARRANTY

### 9.1 WARRANTY

Draper tools have been carefully tested and inspected before shipment and are guaranteed to be free from defective materials and workmanship.

Should the tool develop a fault, please return the complete tool to your nearest distributor or contact:

Draper Tools Limited

UK: Chandler's Ford, Eastleigh, Hampshire,  
SO53 1YF. England.

EU: Oude Graff 8, 6002 NL Weert (NL).

Telephone Sales Desk: +44 (0)23 8049 4333 or:

Product Helpline +44 (0)23 8049 4344.

A proof of purchase must be provided.

If upon inspection it is found that the fault occurring is due to defective materials or workmanship, repairs will be carried out free of charge. This warranty period covering parts/labour is 12 months from the date of purchase except where tools are hired out when the warranty period is 90 days from the date of purchase. This warranty does not apply to any consumable parts, any type of battery or normal wear and tear, nor does it cover any damage caused by misuse, careless or unsafe handling, alterations, accidents, or repairs attempted or made by any personnel other than the authorised Draper warranty repair agent.

**Note:** If the tool is found not to be within the terms of warranty, repairs and carriage charges will be quoted and made accordingly.

This warranty applies in lieu of any other warranty expressed or implied and variations of its terms are not authorised.

Your Draper warranty is not effective unless you can produce upon request a dated receipt or invoice to verify your proof of purchase within the warranty period.

Please note that this warranty is an additional benefit and does not affect your statutory rights.

**Draper Tools Limited.**

## 10. DISPOSAL

### 10.1 DISPOSAL

- At the end of the machine's working life, or when it can no longer be repaired, ensure that it is disposed of according to national regulations.
- Contact your local authority for details of collection schemes in your area.

In all circumstances:

- Do not dispose of power tools with domestic waste.
- Do not incinerate.
- Do not dispose of WEEE\* as unsorted municipal waste.



\* Waste Electrical & Electronic Equipment.