

easee

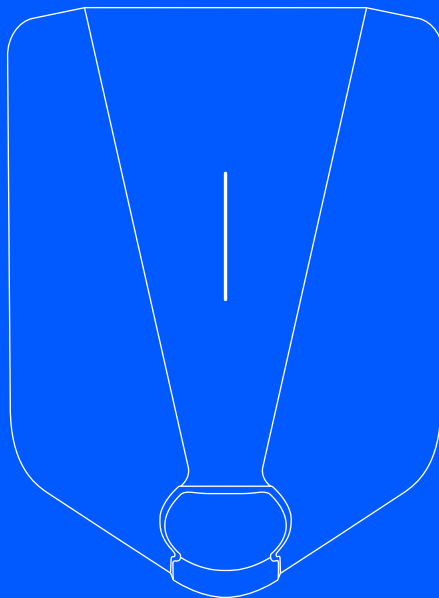

User guide / Installation guide

# Easee One

# Table of contents

## **Introduction**

Introduction	3
Product overview	4
Features	5
Technical specifications	6

---

## **Safety**

Safety instructions	7
---------------------	---

---

## **Before the installation**

Planning the installation	8
---------------------------	---

---

## **Installation**

Installation instructions	10
---------------------------	----

---

## **Daily use and operation**

How do I charge?	16
Apps and interfaces	16
Charging Robot interface	17
Maintenance	18
Practical details	18

### **IMPORTANT:**

Read carefully before use. Keep for future reference.

# Introduction

## Intended use

This product is intended solely for charging electrically powered vehicles equipped with non-gassing batteries (e.g. lead-acid batteries). Easee One is specifically intended for 1-phase installations in the UK fulfilling the additional security requirements for detection of missing PEN conductor according to BS 7671:2018/A1:2020 when wired as a TN-S-C system (see page 12).

The product shall only be used with a charging cable according to IEC 62196. The product must be firmly mounted on a wall or structure that covers the entire back side of the product and has a sufficient load-bearing capacity. It may only be operated with the approved operating parameters and under the specified environmental conditions (see page 6).

Uses other than those specified here are not permitted.

## Conventions



This symbol indicates that the respective instructions must only be carried out by an authorised electrician.



This symbol indicates an immediate danger to life and health of individuals due to the effects of electrical energy. Non-observance of these instructions will result in serious damage to health - up to and including life-threatening injuries.

# Product overview

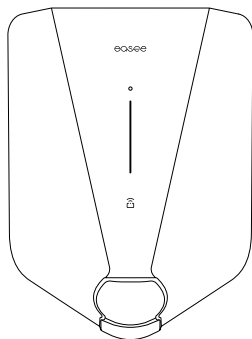

## Front cover

Protects the electronics from external influences.

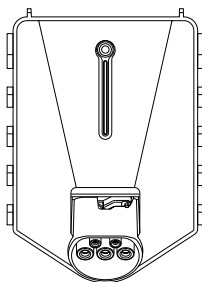

## Chargeberry

Contains the electronics for charging the vehicle.

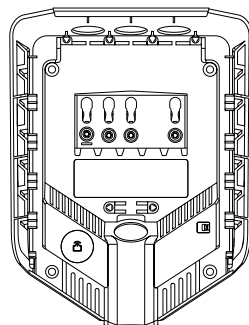

## Backplate

For attaching and connecting to the charging infrastructure.

---

## Installation kit



x2



x3



x2



x5



x4

## Tool



x1

# Features

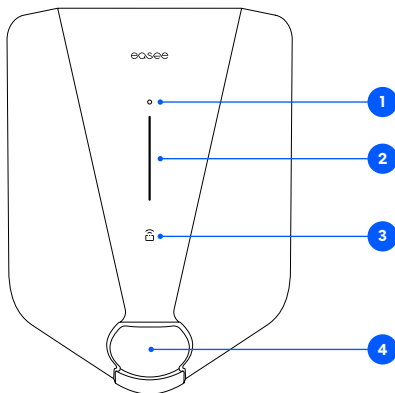

- 1. Touch button:** The touch button is used to activate the WiFi interface which is then used to configure the backplate during installation. This must be done by a certified electrician. Afterwards the WiFi interface can be used as a fallback solution for controlling the Charging Robot in case it is offline (no Internet and Easee App support). The touch button may serve additional functions. Please use the online knowledge-base for other possible touch combinations and functions.
- 2. Light strip:** The light strip communicates the status of the Charging Robot at all times. Read more about this on page 17.
- 3. RFID area:** The integrated RFID reader enables access control of the Charging Robot and identification of different users. You can use it to unlock the charger with an Easee Key. Check our knowledge base at [easee.support](#) for more details on how to add and manage your Easee Keys.
- 4. Type 2 socket:** The Type 2 socket is completely universal and allows you to charge any type of electric vehicle using the appropriate charging cable. Furthermore, it is possible to permanently lock the charging cable, so you do not have to worry about it being stolen.

# Technical specifications

## General

Dimensions (mm): 256 x 193 x 106 (H x W x D)  
Wall mounting (mm): c/c 160 x 125 (H x W)  
Operating temperature: -30 °C to +50 °C  
Weight: 1.5 kg

## Charging

Charging power: 1.4–7.4 kW (6 A – 32 A)  
Max output current: 32 A  
Connection point: Type 2 socket (IEC 62196-2)  
Number of phases: 1  
Voltage: 230 V AC – single phase ( $\pm 10\%$ )  
Mains frequency: 50/60 Hz  
Accuracy of built in energy meter ( $\pm 2\%$ )  
Load balancing of up to 3 units per circuit by integrated wireless communication  
Offline proof load-balancing  
Automatic queuing system

## Sensors and indicators

Light strip with LEDs showing the status of the charger  
Touch button for manual adjustment  
Temperature sensors in all main contacts

## Connectivity

Built-in eSIM (LTE Cat M1/ 2G /GPRS)  
WiFi 2.4 GHz b/g/n connection  
Easee Link RF™  
Control charging via Easee App  
RFID/NFC reader (NFC / ISO 14443 and MIFARE Classic®)  
OCPP 1.6 via our API

## Protection

Integrated overload protection according to EN IEC 61851-1:2019  
Built-in RCD for ground fault protection (30 mA AC/ 6 mA DC) according to EN 61008-1 and IEC 62955  
Integrated protection for open / break fault condition in supply PEN conductor according to BS 7671:2018/A1:2020  
Degree of protection: IP54 (the backplate is IP22 without cover)  
Impact resistance: IK10  
Fire class: UL94  
Insulation class: II  
Overvoltage category III

## Installation

Installation network: TT, TN-S, TN-C and TN-C-S  
Installation circuit breaker: Max 40 A overload protection. The short-circuit current at the charging point (IkMax) must not exceed 10 kA. If required by the installation method, type-A earth fault protection can be used for the circuit.  
Cable cross-section: up to 16 mm<sup>2</sup> (single cable)/ up to 10 mm<sup>2</sup> (parallel connection)  
Cable diameter: 8–22 mm  
Terminal tightening: 5 Nm  
Cable strip length: 12 mm

# Safety instructions

**Read the entire manual carefully before installing and operating the product. Observe the following instructions:**

## **Safety instructions for the installation**

- This product shall only be installed, repaired or serviced by an authorised electrician. All applicable local, regional and national regulations for electrical installations must be respected.
- Danger to life due to high electrical voltage. Never make any changes to components, software or connecting cables.
- The installation must not be carried out in the vicinity of explosive atmospheres or in areas where there is a risk of flowing water.
- The product must be installed on a permanent location. The connections of the Chargeberry and backplate are designed for a limited number of plugging cycles.
- The product must be installed on a wall or structure with sufficient load bearing capacity.
- The charger must always be installed on a surface that covers the entire back side area of the product.
- The terminals in the backplate are energised when the power circuit is closed and must never be in direct contact or in contact with anything other than the plug-in electronics (Chargeberry).
- The PIN code is located on the front of the Chargeberry and is required for installation. After installation, paste the PIN code on the back of the manual or in a safe place, e.g. inside of the fuse cabinet door.

## **Safety instructions for operation**

- Danger to life due to high electrical voltage. Never make any changes to components, software or connecting cables.
- Never use or touch the product if it is damaged or does not function properly.
- Always have the prescribed maintenance, installation and any repair work carried out by an authorised electrician and in accordance with local requirements.
- If a fire occurs, use CO2 for extinguishing. To extinguish it with water or foam, the system must be first de-energized (electrically disconnected).
- Never clean the Charging Robot with high pressure or running water.
- Do not immerse the product in water or other liquids.
- If the light strip on the product lights up red, there is a fault. For more information, see page 17.
- Make sure that children do not play with the product.
- Never touch the contacts of the Type 2 socket and never insert foreign objects into the product.
- Never use the charging cable if it is damaged or if the connections are wet or dirty.
- Do not use extension cords or adapters in combination with the product.
- The charging cable must only be removed from the Charging Robot by pulling the plug handle, not by pulling the cable.
- Make sure the charging cable does not cause a tripping hazard or risk being run over by a car.
- Avoid direct sunlight for optimal operation in all weather conditions.
- Do not use the product near strong electromagnetic fields or in the direct vicinity of radio transmitters.

# Planning the installation



**WARNING!** This product shall only be installed, repaired or serviced by an authorised electrician. All applicable local, regional and national regulations for electrical installations must be respected.

Prior to the installation, it is recommended that you consider future charging needs, so that you can easily expand accordingly in the future.

If several Charging Robots are connected to the same circuit, the total current is dynamically distributed between them. The connected Charging Robots communicate wirelessly between themselves, ensuring that the specified total current of the charging infrastructure is not exceeded. The maximum charging current is set during configuration.

## Check the following before starting the installation

- Where should the Charging Robot be installed?
- Is the connected electrical load of the house sufficient or does it need to be increased? Does a new cable have to be laid? (An external approval may be required). Should the incoming supply cable be upgraded?
- Do you intend to install additional Charging Robots in the future?
- How is the electrical circuit protected?
- Which installation method is planned to be used?

## Pay attention to the following when planning the installation

- The correct selection of the grounding/earthing system, conductors and protective measures (basic protection/ fault protection).
- The correct insulation of touchable and conductive parts.
- Sufficient dimensioning of cables.
- The selection of the overcurrent and overvoltage protection.
- The correct calculation of the short-circuit current as well as a short-circuit proof installation method.

## Residual Current Device (RCD)

A Residual Current Device (RCD), according to EN 61008-1 and IEC 62955, is integrated in the Charging Robot. This will switch off the current to the electrical vehicle if a residual current of 4-6mA DC and/or 20-30mA AC occurs. The RCD is reset by unplugging the charging cable and plugging it in again. The integrated RCD is automatically tested and calibrated at regular intervals by the Charging Robot.

The integrated RCD has no influence on the function of external protective devices. If a Class II installation is supplying the Charging Robot(s), an RCD device is not required to protect Easee One. The decision to install an RCD upstream of the Easee One should be taken in accordance with local wiring regulations.

## For an optimal result, we recommend that you do the following

- If possible, use the largest approved cable cross-section (see page 6).
- Consider the installation of Easee One Ready backplates if the acquisition of further Charging Robots is planned for the future.
- To avoid overloading the building's main fuse, the Easee Equalizer can be used for dynamic load balancing. The maximum current value can also be set as required during configuration.

### Special notes for Easee One

- Easee One is specifically designed to comply with clause 722.411.4.1 of BS 7671:2018 A1. It includes a protection mechanism to completely disconnect the vehicle in case an indication of a broken PEN conductor is detected.
- If the charging infrastructure includes more than one Charging Robot, the Charging Robot that is configured first becomes the master of its circuit.
- If more than 2 units are installed, the master unit should be located in the middle of the installation (if possible) for an optimal Easee Link communication.

### Technical notes for Easee One

- The circuit with one or more Charging Robots can be fused up to 40 A as long as the maximum short-circuit current (I<sub>pk, max</sub>) of 10 kA is not exceeded.
- A maximum of 3 Charging Robots on the same circuit is supported with Easee One.

### Your house, power grid and EV

The Charging Robot automatically adapts to the power grid, the electric car and the capacity of the electrical installation. In the following table, you can see what charging effect you can achieve in your installation and situation. The table is only meant as a guide.

**NOTICE!** The type of installation as well as cable cross-sections must be determined by a qualified electrician in accordance with valid local, regional and national regulations for electrical systems.

Indicative Circuit Fuse Size	Rated setting on Charging Robot <sup>1</sup>	1 phase, 230 V TT / TN-S <sup>2</sup>
Ampere (A)	Ampere (A)	Power (kW)
10	8	1,8
16	13	3
20	16	3,7
25	20	4,6
32	25	5,8
40	32	7,4

<sup>1</sup> Protection limit based on max 80% of the fuse rating can be set in the WiFi interface.

<sup>2</sup> Example for 230 V TT / TN-S, deviating values for other grid types.

# Installation instructions



**WARNING!** This product shall only be installed, repaired or serviced by an authorised electrician. All applicable local, regional and national regulations for electrical installations must be respected.



**WARNING!** Turn off the power before you begin the wiring. Use extreme caution and follow instructions carefully.



In addition to the instructions presented on the next pages, we recommend that you watch the installation videos available on our website: [easee.support](http://easee.support).

## 1 Charging Robot Opening

**WARNING!** Be sure to read the safety instructions (page 7) of this product before you start the installation.

1. Bend down the lower part of the rubber cover and insert the two ends of the supplied tool into the two openings at the bottom of the front cover.
2. Pull the tool until the front cover comes loose and remove the cover.
3. Grasp the Type 2 socket and push upwards with good force until the Chargeberry disconnects.

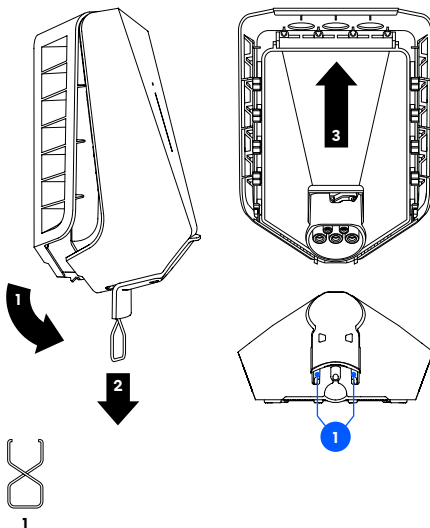

## 2 Backplate Mounting

1. Fix the backplate to a wall or structure with sufficient load-bearing capacity using the 4 screws provided in the mounting kit. Use suitable wall plugs for mounting and observe the recommended installation height (see below).
2. Turn off the power before proceeding with the installation.

**NOTICE!** If you are going to install multiple backplates, now would be a good time to mount them as well.

**IMPORTANT!** The installation wall must cover the entire back of the product.

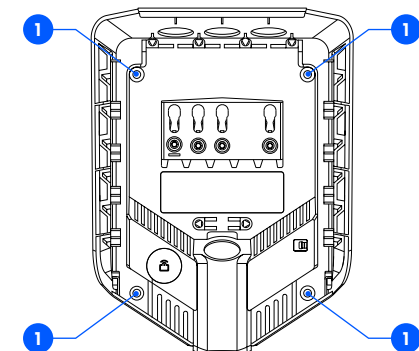

130-140 cm

Recommended installation height

## 3 Backplate Preparing

1. Shorten the sealing plug to fit the cable. The hole should be slightly smaller to ensure a good seal.
2. Insert the cable through one of the 4 cable entries and secure it to the backplate with the strain relief provided.
3. Close all cable entries that are not in use with the blind sealing plugs supplied.

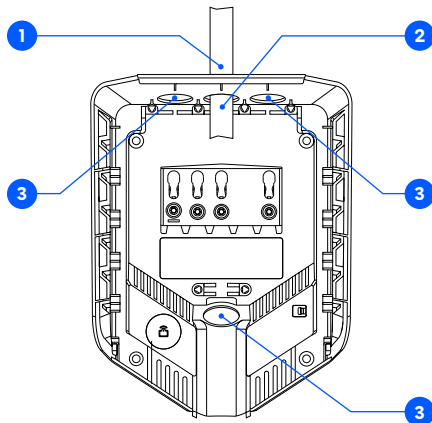

# 4 Backplate Wiring

1. Strip the individual wires by 12 mm. If the cable has flexible conductors, it is recommended to use ferrules on stranded wires. Use correct tools to press them.
2. Tighten the screw terminal with a torque of 5 Nm.

**NOTICE!** When connecting multiple backplates in parallel, each screw terminal serves as a coupling point for adjacent backplates. External junction boxes or flat cables can be used if it is preferred.

**NOTICE!** It's recommended to follow the existing colour codes used in the installation. Depending on national standards, the colours of the cables can vary from the illustrations. The illustrations in this manual follow the IEC 60446 standard.

**NOTICE!** Protection against a broken PEN conductor fault is only active when wired according to the TN-C-S diagram.

**NOTICE!** Never connect Earth to both the PE and PEN terminal.

**NOTICE!** Before turning on the power, make sure the wires are properly connected and tightened. Test this by pulling on each wire.

TT / TN-S network

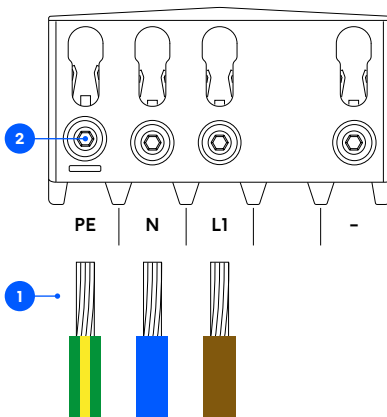

TN-C-S network (PME)

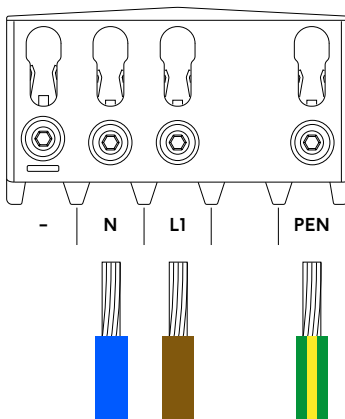

# 5 Backplate Installing

1. Scan the QR code to download the Easee Installer App and create a free account.

**NOTICE!** Your phone needs to support NFC.

2. Select one of the three site setups in the Installer App:

**Create new site:** If this is a completely new charging site, select "Create new site". Enter the installation details, follow the on-screen instructions and return to this guide afterwards.



**Ongoing sites:** If you have an incompletd site, e.g. with missing information or not uploaded to the Cloud, go to "Ongoing sites" and complete them.

**Update existing site:** If this site already has one or more Charging Robots installed or if it has been created by an operator, select "Update existing site" and search for the site address. On "Site overview", select the circuit that you want the backplate to be part of and select "Add another backplate". Follow the on-screen instructions and return to this guide afterwards.

**NOTICE!** If the charging circuits include more than one Charging Robot, the backplate that is configured first becomes the master unit of the charging infrastructure. To achieve the best communication flow, the centre backplate should be configured first.

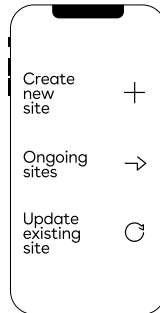

# 6 Chargeberry Attaching

1. **WARNING!** Turn on the power. The terminals of the backplates are now electrically live.
2. Position the Chargeberry to fit into the slots on the backplate located in the center of the installation.
3. When the Chargeberry is in the track, press it forcefully down until you hear a click.

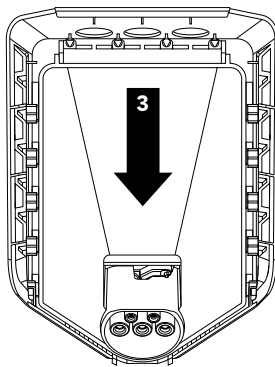
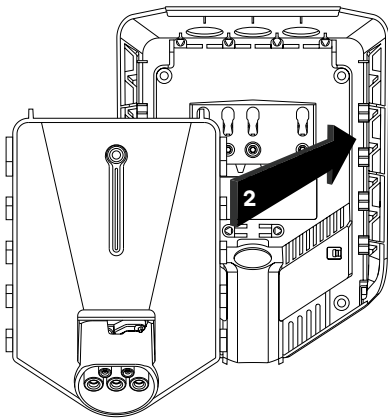

**"CLICK!"**

# 7 Front cover Closing

Before closing the front cover, it is possible but optional to lock the Chargeberry with a padlock (see recommended padlock size on page 19). Locking the electronics adds an extra level of security (padlock is not included).

1. Hang the front cover at the top of the backplate and let it fall into place.
2. Press the bottom of the front cover until you hear a click.
3. Bend the lower part of the rubber cover down.
4. Screw in the locking screw at the bottom of the charger to secure the front cover.
5. Close the rubber cover. If the cable is inserted from the bottom, you can cut a corresponding hole in the rubber cover to ensure a neat installation.

**Your Charging Robot is now ready for use!**

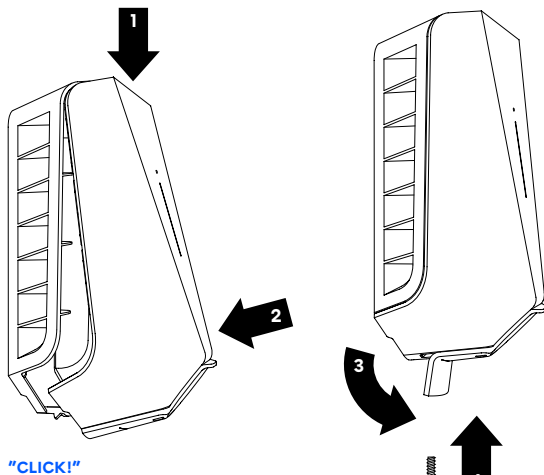
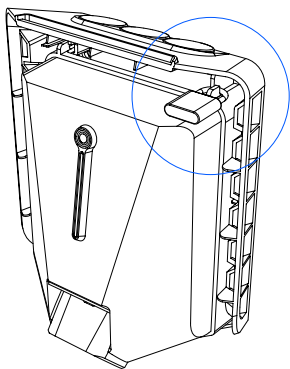

4

# How do I charge?

**WARNING!** Observe the safety instructions on page 7 before using the product.

Make sure that the following requirements are met before using the Charging Robot:

- The authorised electrician have set up the electrical connection properly.
  - The charger is properly configured.
  - The software is up to date (see page 17).
  - If you have set up access control, unlock it by using a registered RFID tag or disable it from the Easee App or the local WiFi interface.
1. Check the charging cable and connector for damage and impurities such as foreign objects and water ingress before charging.
  2. Connect the charging cable to the Charging Robot and your electric car. The charging process starts and adapts automatically to the electric car and the available energy at any time according to the configuration.

If the car does not start charging, check that charging is activated in your car and that the connectors are properly plugged in. If charging still does not start, check what might be the cause on page 17.

## Smart charging

Some operators offer smart charging which will delay charging to a suitable point in time, often tied to electricity price or similar mechanisms. When Smart charging is active the LED strip is lit blue, charging will not start until the operators criteria for charging is met. Contact you operator to know more and to find out if they offer this service.

# Apps and interfaces

## WiFi interface

The WiFi interface is currently intended for local operations of the charger when no internet is available, but it will soon be replaced with local control in the Easee App to make your life even easier.

To access the WiFi interface follow the guide: [support.easee.com/help/s/article/WiFi-Interface](https://support.easee.com/help/s/article/WiFi-Interface)

## Easee App

The Easee App is intended for everyday use of your Easee products. It can be used anywhere in the world through the Easee Cloud.

The Easee App can be downloaded from the application store of your iOS or Android mobile device.



## Easee Portal

The Easee Portal is a tool intended for administration of one or several Easee sites.

The Portal is mainly intended for site owners, installers, administrators, service providers and people who need to manage several products and sites from one interface.

Go to [easee.support](https://support.easee.com) for more information on our interfaces.

# Charging Robot interface

Light description	Status
White - constant light, only at the bottom 2 LEDs - master unit / 1 LED - secondary units	Standby
White - constant light	Car connected
White - pulsating light	Charging in progress
Blue - constant light	Smart charging enabled (car connected)
Blue - pulsating light	Smart charging in progress
At startup, the LEDs turn on one by one. When the charger is updating, one or more LEDs will flash green while this is in progress.	Updating software (updating can take up to 30 minutes) <b>NOTICE!</b> The car must be disconnected before a software update can be completed.
White - flashing light	Waiting for authentication by an RFID tag. Hold the RFID tag against the RFID area of the Charging Robot in order to authenticate and initiate the charging.
White - fast flashing light	RFID-tag received (awaiting key verification)
Red - constant light	General error. Unplug the charging cable and replug it to the Charging Robot. If the red light persists, check the Easee App or our knowledge base <sup>3</sup> for further information.
Red - constant light, with warning sounds	Broken PEN lead detected or wires are connected incorrectly. Consult an authorised electrician.
Red - pulsating light	The Charging Robot has measured an abnormal temperature and has entered in safe mode. Please go to our knowledge base <sup>3</sup> for further information.
White - flashing light, only at the bottom	The Charging Robot is searching for its master unit. Please check the status of the master unit. For further information, please check our knowledge base <sup>3</sup> .
Yellow - flashing light, only at the bottom	The Charging Robot is waiting to be configured. Consult an authorised electrician.

<sup>3</sup> Easee public knowledge base can be found at [easee.support](https://www.easee.com/support).

# Maintenance

## General maintenance

If the product is installed in public spaces and is accessible to everyone, observe local and national requirements (e.g. BS 7671) in addition to the procedures below.

- Ensure that the charger does not have any signs of mechanical damage.
- Visually inspect the Type 2 socket for wear and tear at regular intervals according to local regulations. If the pins are discoloured or damaged, please contact your authorised electrician.

## Cleaning

The product does not require cleaning to operate properly. Nevertheless, if the product needs to be cleaned for cosmetic reasons, this is possible.

- Use a damp cloth and an all-purpose household cleaner. Avoid using strong chemicals that contain oil or alcohol, as this will discolour the plastic.
- Do not use running water or high pressure water jets.

## Insulation testing (authorised electrician only)



Insulation testing should be performed before a Chargeberry is installed in the backplate. Testing the circuit insulation with the Chargeberry installed in the backplate may damage the electronics or impact the reading negatively.

# Practical details

## Warranty

The device is free from material defects and is in accordance with laws and regulations for consumer protection in the country where the product is purchased. All correctly installed Easee hardware is covered by our 3 years\* limited warranty. If your charger needs to be repaired within this warranty period, please contact your Easee supplier. Further information can be found at [easee.support](https://www.easee.com/support).

\*Some countries may have extended warranty.

## Safety

The product shall be installed according to local regulations for low voltage electrical installations. The product is designed and tested according to the EN 61851 standards for electric vehicle conductive charging system. It includes a built-in RCD able to safely break the circuit in the event of a 30 mA AC or 6 mA DC fault in accordance with IEC 61008 and IEC 62955. The charger also has an integrated broken PEN lead protection according to BS 7671:2018/A1:2020.

## Standards

Hereby, Easee AS declares that this product, Easee One, is in compliance with the Electrical Equipment Safety Regulations 2016, Radio Equipment Regulations 2017, EMC Regulations 2016 and RoHS Regulations 2012.

The full text of the UK Declaration of Conformity is available at the following internet address: [easee.support](https://www.easee.com/support).

## Max transmitted power

**Radio:** 100 mW at 863–870 MHz. **WiFi:** 50 mW at 2.4–2.472 GHz. **GSM:** 2 W at 880–915 MHz, 1 W at 1710–1785 MHz, 200 mW at 703–748 MHz, 832–862 MHz, 880–915 MHz, 1710–1785 MHz and 1920–1980 MHz.

## Product life cycle

**Transportation:** The charger should always be transported within its original packaging. No other items should be stored on top of the box other than Easee chargers. Should the box be dropped or otherwise impacted, a visual inspection should be done in order to verify potential damage.

**Storage:** The electronics are hermetically sealed and will not get damaged if stored in humid areas. However, in order to preserve the packaging and its contents, we recommend storage in a tempered, dry and well-ventilated area. Relative humidity should not exceed 80% and no corrosive gas should be present. Storage or transportation environment must never exceed the limits provided in the technical specifications of the charger (see page 6).

**Dismounting:** Perform a factory reset of the device before powering it down. This is done via the Installer App. Dismounting shall only be performed by an authorised electrician. The power supply to the charger must be isolated before dismounting starts. Use the installation guide and follow the steps in reverse in order to dismount the Charging Robot in the correct order.



**Disposal:** This electronic equipment must not be disposed of in household waste. For the return of old devices, free collection and acceptance points may be available in your vicinity. Observe local regulations for correct and environmentally friendly disposal. If the old electronic equipment contains personal data, you are responsible for deleting it yourself before returning it.

## Padlock dimensions

Max total lock height: 56 mm. Shackle height (outer dimension): 19–20 mm. Shackle thickness: 3.2–4 mm.

## Data protection

When the product connects to the Internet, personal data is sent to Easee AS. You will receive more information about data protection during the configuration of your Charging Robot.

## Repair

If your charger needs to be repaired, please contact your Easee supplier.

## Returns and complaints

Contact your distributor or Easee Customer Support regarding the return and complaint of your product.

## Customer support

Download the latest manuals, find answers to frequently asked questions and useful documents and videos for your product at [easee.support](https://www.easee.com/support).

## Contact details

Easee AS  
Grønseveien 19  
4313 Sandnes, Norway  
Org. nr: 920 292 046

You can find additional contact details for your country at [easee.com](https://www.easee.com).

THIS DOCUMENT CONTAINS INFORMATION THAT IS  
SUBJECT TO CHANGE WITHOUT NOTICE.

The latest version of this publication can be downloaded  
at <http://easee.support>

No part of this publication may be reproduced or  
transmitted in any form or by any means, electronic  
or mechanical, including, but not limited to, copying,  
recording, retrieving data, or computer networks without  
the written permission of Easee AS.

Easee and all other Easee product names and slogans  
are trademarks or registered trademarks of Easee AS.  
Easee products can be protected by one or more  
patents.

All other products and services mentioned may be  
trademarks or service marks of their respective owners.

Illustrations of the product and user interface are  
exemplary and may differ from the actual appearance.

April 2022 - Version 1.05

© 2021 by Easee AS. All rights reserved.



---

easee

Easee AS  
Grenseveien 19  
4313 Sandnes, Norway  
[www.easee.com](http://www.easee.com)