

# 4 Set-up and Lubricate

## Adjust Bearing Position

- 1** Measure the distance between the release bearing and the clutch brake. The correct distance should be 0.500" – 0.560" (12.70 – 14.22 mm). If correct go to Step 3.

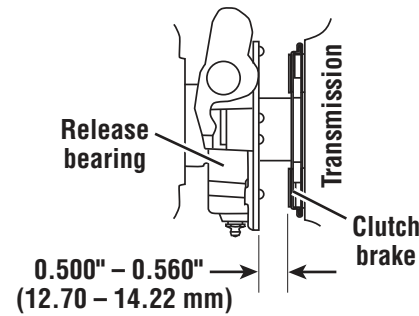

- 2** To change bearing position, you must internally adjust the clutch. Push pedal and hold pedal down when adjusting. Follow instructions for Kwik-Adjust or Value Clutches.

**Kwik-Adjust Clutches**  
Push and turn adjusting nut. Clockwise moves the bearing toward transmission.

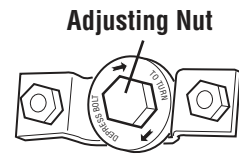

**Value Clutch**  
Remove lockstrap, then rotate adjusting lugs left to move bearing toward transmission. Replace lockstrap.

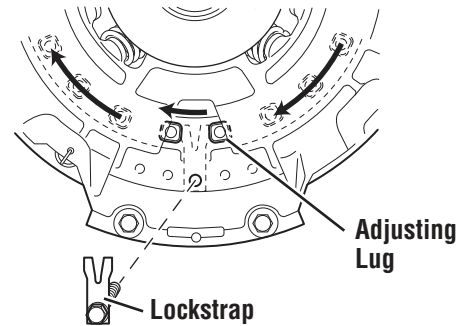

## Verify Clutch Brake Squeeze

- 3** Insert 0.010" (0.25 mm) feeler gauge between the release bearing and the clutch brake. Press the pedal down to clamp the gauge.

- If the gauge does not clamp, adjust linkage to achieve clutch brake squeeze then recheck **Step 3**.

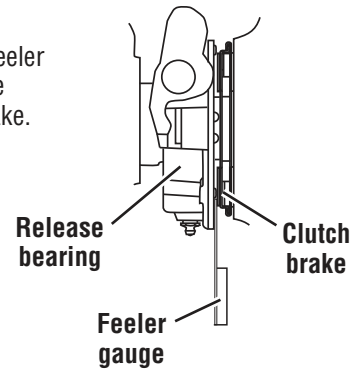

- 4** Slowly let up on the pedal and check the pedal position at the moment the gauge can be removed.

- If the pedal is less than 1/2" (12.7 mm) or more than 1" (25.4 mm) from the floor when the gauge can be removed, readjust the linkage. (Repeat **Steps 3** and **4**.)

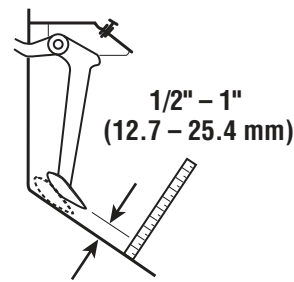

## Verify Free-Play

- 5** Check distance between yoke tips and bearing wear pads. This distance should be 1/8" (3.2 mm).

- !** Do not change bearing position.

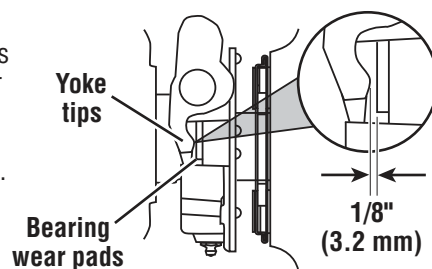

- 6** To change the yoke finger and bearing wear pads clearance, adjust the upper pedal stop to raise or lower the pedal in the cab.

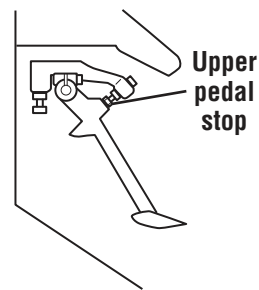

## Lubricate

**!** **Important:** Eaton recommends the use of Roadranger EP2 for release bearing lubrication, or an equivalent Lithium Complex, NLGI #2 or #3 grease with a NLGI LB/GC performance rating and a dropping Point temperature of 220° C (428° F) or higher. Failure to use the proper grease may affect bearing life and void the warranty coverage on your Eaton product.

Apply ample grease that visibly exits the opening and contacts the transmission shaft. This will lube the clutch brake when pedal is pressed.

- 7** Apply grease to the input shaft and yoke.

- 8** Apply grease to the cross shaft bushings and linkage pivot points.

- 9** Grease the release bearing until grease purges from the rear of the release bearing onto the input shaft.

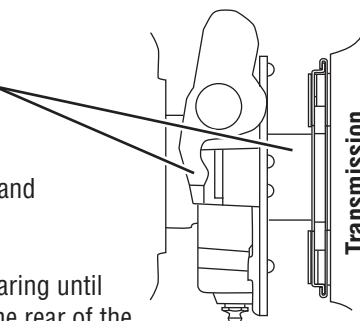

## Installation Procedure

# Eaton 14" and 15.5" Heavy-Duty Manual Adjust Clutch CLMT1351 EN-US

May 2016



BACKED BY  
**Roadranger**  
SUPPORT

**Eaton**  
Vehicle Group  
P.O. Box 4103  
Kalamazoo, MI 49003 USA  
800-826-HELP (4357)  
www.eaton.com/roadranger

Copyright Eaton, 2016.  
Printed in USA  
Reference Materials  
CLSM200 and CLSL1511



# 1 Measure

## Measure Engine Flywheel Housing and Flywheel

Engine flywheel housing and flywheel must meet these specifications or there will be premature clutch wear. Remove old Pilot Bearing. All gauge contact surfaces must be clean and dry. Use a dial indicator and check the following:

### Flywheel Face Runout

Secure dial indicator base to flywheel housing face. Put gauge finger in contact with flywheel face near the outer edge. Rotate flywheel one revolution. Maximum runout is 0.008" (0.20 mm).

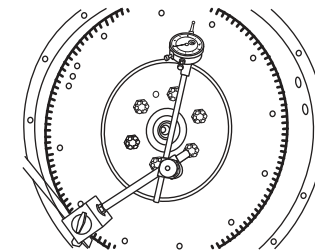

### Flywheel Housing I.D. Runout

Secure dial indicator base to crankshaft. Put gauge finger against flywheel housing pilot I.D. Rotate flywheel one revolution. Maximum runout is 0.008" (0.20 mm).

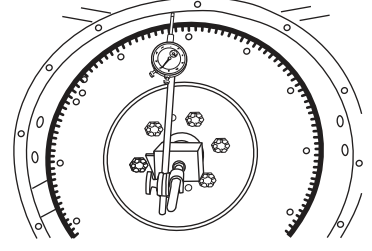

### Pilot Bearing Bore Runout

Secure dial indicator base to flywheel housing face. Position gauge finger so that it contacts pilot bearing bore. Rotate flywheel one revolution. Maximum runout is 0.005" (0.13 mm).

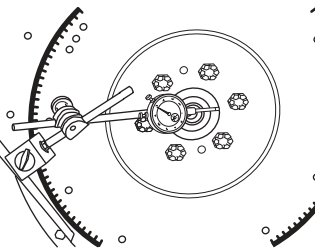

### Flywheel Housing Face Runout

Secure dial indicator base to flywheel near the outer edge. Put gauge finger in contact with face of flywheel housing. Rotate flywheel one revolution. Maximum runout is 0.008" (0.20 mm).

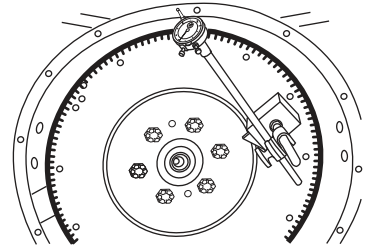

## 2 Install Clutch to Flywheel

For 15.5" clutch only:

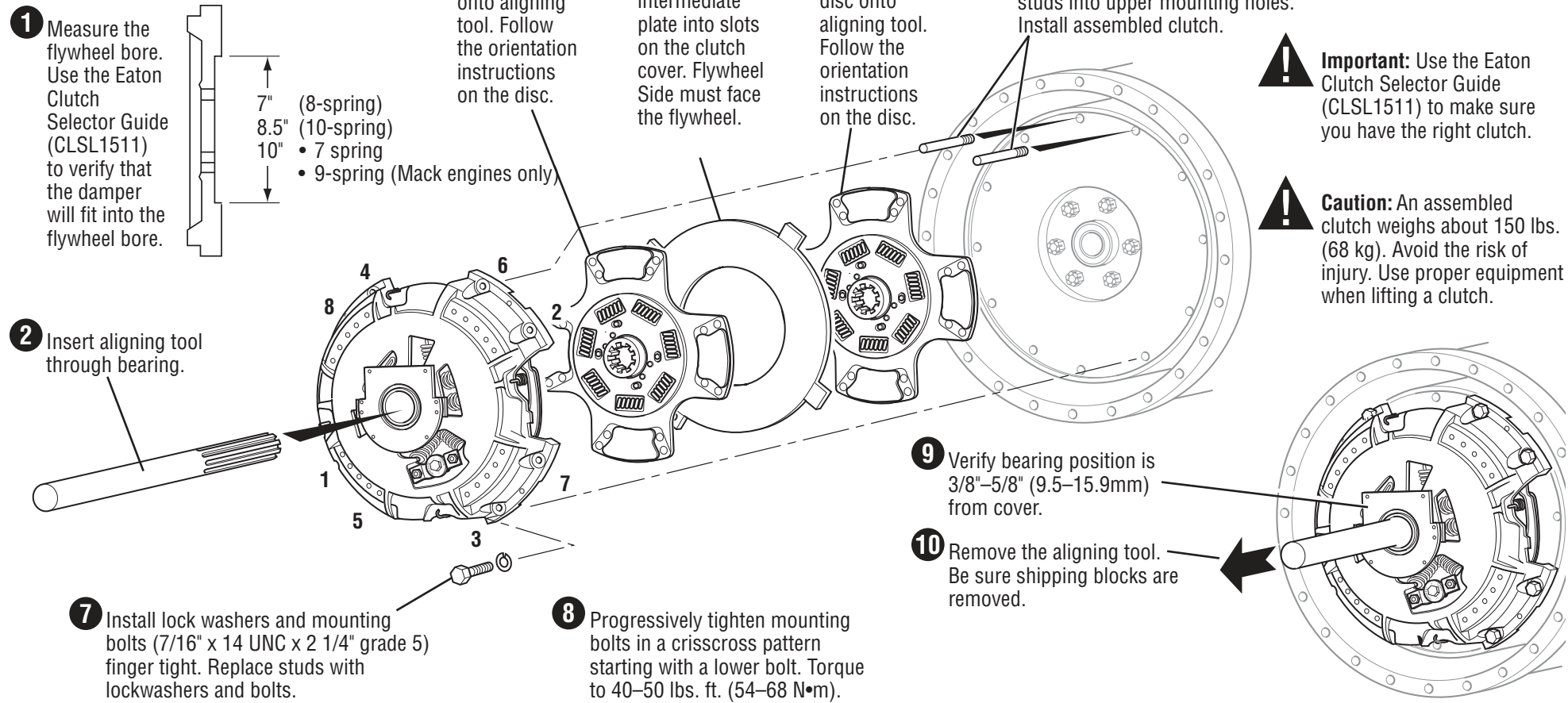

For 14" clutch only:

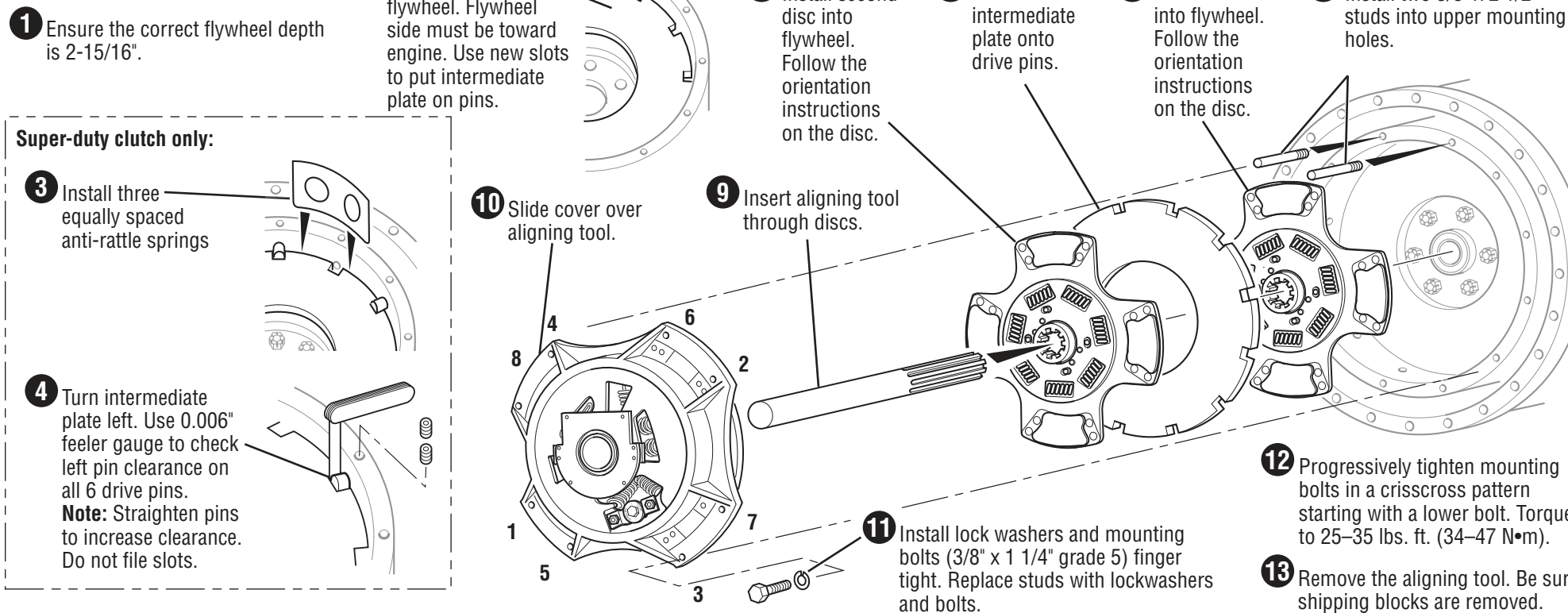

## 3 Install Transmission

Check Transmission For Wear

Replace any worn components.

**Transmission Bearing Retainer Cap**  
A worn/rough bearing retainer cap may cause the clutch brake to wear prematurely.

**Release Yoke**  
Worn fingers can cause bushing wear and yoke interference when the pedal is down.

**Input Shaft**  
Wear (roughness) can reduce sleeve bushing life and cause it to come out.

**Cross Shaft and Bushings**  
Excessive wear at these points can cause side loading on the sleeve bushing, bushing failures and yoke bridge contact with the clutch when the pedal is down.

**Input Shaft Splines**  
Any wear on the splines will prevent the driven discs from sliding freely, causing poor clutch release (clutch drag). Slide discs full length of shaft to check for twisted shaft splines.

**Clutch Brake**  
Replace.

**Measure Input Shaft**  
Length should be 8.657" (219.89 mm) nominal, and not greater than 8.71" (221.23 mm). Ref. 1990 SAE handbook 4:36.106. Replace transmission bearing retainer cap if length is greater than 8.71" (219.89 mm).

Fasten Transmission To Flywheel Housing

Transmission installation and clutch set-up procedures are the same for the 14" and 15.5" clutch.

