

SIXPAR 100IP™
user manual

©2020 ELATION PROFESSIONAL all rights reserved. Information, specifications, diagrams, images, and instructions herein are subject to change without notice. ELATION PROFESSIONAL logo and identifying product names and numbers herein are trademarks of ELATION PROFESSIONAL. Copyright protection claimed includes all forms and matters of copyrightable materials and information now allowed by statutory or judicial law or hereinafter granted. Product names used in this document may be trademarks or registered trademarks of their respective companies and are hereby acknowledged. All non-ELATION brands and product names are trademarks or registered trademarks of their respective companies.

ELATION PROFESSIONAL and all affiliated companies hereby disclaim any and all liabilities for property, equipment, building, and electrical damages, injuries to any persons, and direct or indirect economic loss associated with the use or reliance of any information contained within this document, and/or as a result of the improper, unsafe, insufficient and negligent assembly, installation, rigging, and operation of this product.

Elation Professional USA | 6122 S. Eastern Ave. | Los Angeles, CA. 90040

323-582-3322 | 323-832-9142 fax | www.elationlighting.com | info@elationlighting.com

Elation Professional B.V. | Junostraat 2 | 6468 EW Kerkrade, The Netherlands

+31 45 546 85 66 | +31 45 546 85 96 fax | www.elationlighting.eu | info@elationlighting.eu

Elation Professional Mexico | AV Santa Ana 30 | Parque Industrial Lerma, Lerma, Mexico 52000

+52 (728) 282-7070

DOCUMENT VERSION



Due to additional product features and/or enhancements, an updated version of this document may be available online. Please scan the QR Code with your mobile device or visit www.elationlighting.com for the latest revision/update of this manual, before installation and/or programming.

Date	Document Version	Software Version ≥	DMX Channel Modes	Notes
2/2015	1	≥1.03	6/7/8/12	Initial Release
09/2020	2	≥1.16	N/C	Updated Primary/Secondary
10/2021	3	N/C	N/C	Updated Introduction
11/2021	4	N/C	N/C	Updated Format

CONTENTS

General Information	4
Limited Warranty (USA Only)	5
Safety Guidelines	6
Overview	8
Installation	10
DMX Setup	13
System Menu	15
Dimmer Mode	17
DMX Channel Functions and Values	18
Maintenance Guidelines	20
Specifications	21
Optional Accessories	23

GENERAL INFORMATION

INTRODUCTION

Please read and understand the instructions in this manual carefully and thoroughly before attempting to operate this device. These instructions contain important safety and use information.

IP65 RATED

An IP rated lighting fixture is one, which is commonly installed in outdoor environments and has been designed with an enclosure that effectively protects the ingress (entry) of external foreign objects such as dust and water. **The International Protection (IP)** rating system is commonly expressed as "**IP**" (Ingress Protection) followed by two numbers (i.e. IP65) where the numbers define the degree of protection. The first digit (Foreign Bodies Protection) indicates the extent of protection against particles entering the fixture and the second digit (Water Protection) indicates the extent of protection against water entering the fixture. An **IP65** rated lighting fixture is one, which has been designed and tested to protect against the ingress of dust **(6)** and low-pressure water jets from any direction **(5)**.

MARINE COASTAL ENVIRONMENT INSTALLATIONS

Please note that although this fixture is IP rated, the fixture is not suitable for marine/or coastal environment installations. Installing this fixture in a marine and/or coastal environment may cause corrosion and/or excessive wear to the interior and/or exterior components of the fixture. Damages and/or performance issues resulting from installation in a marine and/or coastal environment will void the manufacturers warranty and will not be subject to any warranty claims and/or repairs.

Ensure all connections and end caps are properly sealed with a non-conductive dielectric grease (available at most electrical suppliers) to prevent water ingress/condensation and/or corrosion.

OPTIONAL CORROSION-RESISTANT COATING

Optional Corrosion-Resistant Coatings may be available for this fixture. Please consult your Elation Professional sales representative for details.

UNPACKING

Every device has been thoroughly tested and has been shipped in perfect operating condition. Carefully check the shipping carton for damage that may have occurred during shipping. If the carton is damaged, carefully inspect the device for damage, and be sure all accessories necessary to install and operate the device have arrived intact. In the event damage has been found or parts are missing, please contact our customer support team for further instructions. Please do not return this device to your dealer without first contacting customer support. Please do not discard the shipping carton in the trash. Please recycle whenever possible.

BOX CONTENTS

Male Edison to IP Female Power Cable 6,6 ft. (2m)
Male 5pin XLR to IP Female DMX Input Cable 3.3 ft (1m)
Female 5pin XLR to IP Male DMX Output Cable 3.3 ft (1m)
Manual & Warranty Card

CUSTOMER SUPPORT

Contact ELATION Service for any product related service and support needs. Also visit forums.elationlighting.com with questions, comments or suggestions.

ELATION SERVICE USA - Monday - Friday 8:00am to 4:30pm PST
323-582-3322 | Fax 323-832-9142 | support@elationlighting.com

ELATION SERVICE EUROPE - Monday - Friday 08:30 to 17:00 CET
+31 45 546 85 63 | Fax +31 45 546 85 96 | support@elationlighting.eu

REPLACEMENT PARTS please visit parts.elationlighting.com

WARRANTY RETURNS (USA ONLY)

- A. Elation Professional hereby warrants, to the original purchaser, Elation Professional products to be free of manufacturing defects in material and workmanship for a period of two years (730 days), and Elation Professional product rechargeable batteries to be free of manufacturing defects in material and workmanship for a period of six months (180 days), from the original date of purchase. This warranty excludes discharge lamps and all product accessories. This warranty shall be valid only if the product is purchased within the United States of America, including possessions and territories. It is the owner's responsibility to establish the date and place of purchase by acceptable evidence, at the time service is sought.
- B. For warranty service, send the product only to the Elation Professional factory. All shipping charges must be pre-paid. If the requested repairs or service (including parts replacement) are within the terms of this warranty, Elation Professional will pay return shipping charges only to a designated point within the United States. If any product is sent, it must be shipped in its original package and packaging material. No accessories should be shipped with the product. If any accessories are shipped with the product, Elation Professional shall have no liability what-so-ever for loss and/or damage to any such accessories, nor for the safe return thereof.
- C. This warranty is void if the product serial number and/or labels are altered or removed; if the product is modified in any manner which Elation Professional concludes, after inspection, affects the reliability of the product; if the product has been repaired or serviced by anyone other than the Elation Professional factory unless prior written authorization was issued to purchaser by Elation Professional; if the product is damaged because not properly maintained as set forth in the product instructions, guidelines and/or user manual.
- D. This is not a service contract, and this warranty does not include any maintenance, cleaning or periodic check-up. During the periods as specified above, Elation Professional will replace defective parts at its expense, and will absorb all expenses for warranty service and repair labor by reason of defects in material or workmanship. The sole responsibility of Elation Professional under this warranty shall be limited to the repair of the product, or replacement thereof, including parts, at the sole discretion of Elation Professional. All products covered by this warranty were manufactured after January 1, 1990, and bare identifying marks to that effect.
- E. Elation Professional reserves the right to make changes in design and/or performance improvements upon its products without any obligation to include these changes in any products theretofore manufactured.
- F. No warranty, whether expressed or implied, is given or made with respect to any accessory supplied with the products described above. Except to the extent prohibited by applicable law, all implied warranties made by Elation Professional in connection with this product, including warranties of merchantability or fitness, are limited in duration to the warranty periods set forth above. And no warranties, whether expressed or implied, including warranties of merchantability or fitness, shall apply to this product after said periods have expired. The consumer's and/or dealer's sole remedy shall be such repair or replacement as is expressly provided above; and under no circumstances shall Elation Professional be liable for any loss and/or damage, direct and/or consequential, arising out of the use of, and/or the inability to use, this product.
- G. This warranty is the only written warranty applicable to Elation Professional products and supersedes all prior warranties and written descriptions of warranty terms and conditions heretofore published.

WARRANTY RETURNS

All returned service items whether under warranty or not, must be freight pre-paid and accompany a return authorization (R.A.) number. The R.A. number must be clearly written on the outside of the return package. A brief description of the problem as well as the R.A. number must also be written down on a piece of paper and included in the shipping container. If the unit is under warranty, you must provide a copy of your proof of purchase invoice. Items returned without a R.A. number clearly marked on the outside of the package will be refused and returned at customer's expense. You may obtain a R.A. number by contacting customer support.

SAFETY GUIDELINES

This fixture is a sophisticated piece of electronic equipment. To guarantee a smooth operation, it is important to follow all instructions and guidelines in this manual. Elation Professional is not responsible for injury and/or damages resulting from the misuse of this fixture due to the disregard of the information printed in this manual. Only qualified and/or certified personnel should perform installation of this fixture and only the original rigging parts (omega brackets) included with this fixture should be used for installation. Any modifications to the fixture and/or the included mounting hardware will void the original manufacturer's warranty and increase the risk of damage and/or personal injury.



PROTECTION CLASS 1 - FIXTURE MUST BE PROPERLY GROUNDED.



**THERE ARE NO USER SERVICEABLE PARTS INSIDE THIS UNIT.
DO NOT ATTEMPT ANY REPAIRS YOURSELF; DOING SO WILL VOID YOUR
MANUFACTURER'S WARRANTY. DAMAGES RESULTING FROM MODIFICATIONS
TO THIS FIXTURE AND/OR THE DISREGARD OF SAFETY INSTRUCTIONS AND
GUIDELINES IN THIS MANUAL VOID THE MANUFACTURE'S WARRANTY AND
ARE NOT SUBJECT TO ANY WARRANTY CLAIMS AND/OR REPAIRS.**



**DO NOT PLUG FIXTURE INTO A DIMMER PACK!
NEVER OPEN THIS FIXTURE WHILE IN USE!
UNPLUG POWER BEFORE SERVICING FIXTURE!
NEVER TOUCH FIXTURE DURING OPERATION, AS IT MAY BE HOT!
KEEP FLAMMABLE MATERIALS AWAY FROM FIXTURE!**

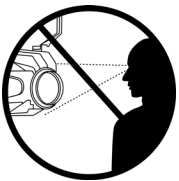

**NEVER LOOK DIRECTLY INTO THE LIGHT SOURCE!
RETINA INJURY RISK - MAY INDUCE BLINDNESS!
SENSITIVE PERSONS MAY SUFFER AN EPILEPTIC SHOCK!**



**MINIMUM DISTANCE TO OBJECTS/SURFACES
MUST BE 65.6 FEET (20 METERS)
MAXIMUM TEMP OF EXTERNAL SURFACE 212° F (100°C)
MINIMUM DISTANCE OF INFLAMMABLE MATERIALS
FROM THE SURFACE 1.6 FEET (0.5 METER)**

SAFETY GUIDELINES

! CAUTION

HIGH INTENSITY ULTRAVIOLET LIGHT



AVOID DIRECT EYE & SKIN EXPOSURE.
WEAR PROPER EYE & SKIN PROTECTION.
SEE MANUAL FOR SAFETY INSTRUCTIONS.

RISK GROUP 3 - RISK OF EXPOSURE TO ULTRAVIOLET UV RADIATION! FIXTURE EMITS HIGH INTENSITY WAVELENGTH OF ULTRAVIOLET UV LIGHT FROM THE UV LED. WEAR PROPER EYE AND SKIN PROTECTION. AVOID PROLONGED PERIODS OF EXPOSURE TO UV LED. AVOID WEARING WHITE COLOR CLOTHING AND/OR USING UV PAINTS ON SKIN. AVOID DIRECT EYE AND/OR SKIN EXPOSURE AT DISTANCES LESS THAN 11 FEET (3.3m).

DO NOT OPERATE FIXTURE WITH DAMAGED/MISSING EXTERNAL COVERS. DO NOT LOOK DIRECTLY INTO THE UV LIGHT AND/OR VIEW UV LIGHT DIRECTLY WITH OPTICAL INSTRUMENTS THAT MAY CONCENTRATE THE LIGHT/RADIATION OUTPUT. INDIVIDUALS SUFFERING FROM A RANGE

OF EYE CONDITIONS, SUNLIGHT EXPOSURE DIS-ORDERS, OR INDIVIDUALS USING PHOTSENSITIVE MEDICATION, MAY RECEIVE DISCOMFORT IF EXPOSED TO THE ULTRAVIOLET UV LIGHT EMITTED FROM THE UV LED.

DO NOT TOUCH the fixture housing during operation. Turn OFF the power and allow approximately 15 minutes for the fixture to cool down before serving.

DO NOT shake fixture, avoid brute force when installing and/or operating fixture.

DO NOT operate fixture if the power cord is frayed, crimped, damaged and/or if any of the power cord connectors are damaged and do not insert into the fixture securely with ease. NEVER force a power cord connector into the fixture. If the power cord or any of its connectors are damaged, replace it immediately with a new one of similar power rating.

DO NOT block any air ventilation slots.

All fan and air inlets must remain clean and never blocked.

Allow approx. 6" (15cm) between fixture and other devices or a wall for proper cooling.

Always disconnect fixture from main power source before performing any type of service and/or cleaning procedure. Only handle the power cord by the plug end, never pull out the plug by tugging the wire portion of the cord.

During the initial operation of this fixture, a light smoke or smell may emit from the interior of the fixture. This is a normal process and is caused by excess paint in the interior of the casing burning off from the heat associated with the lamp and will decrease gradually over time.

Consistent operational breaks will ensure fixture will function properly for many years.

ONLY use the original packaging and materials to transport the fixture in for service.

OVERVIEW

System Menu
LCD & Controls



Mounting Brackets/Yokes

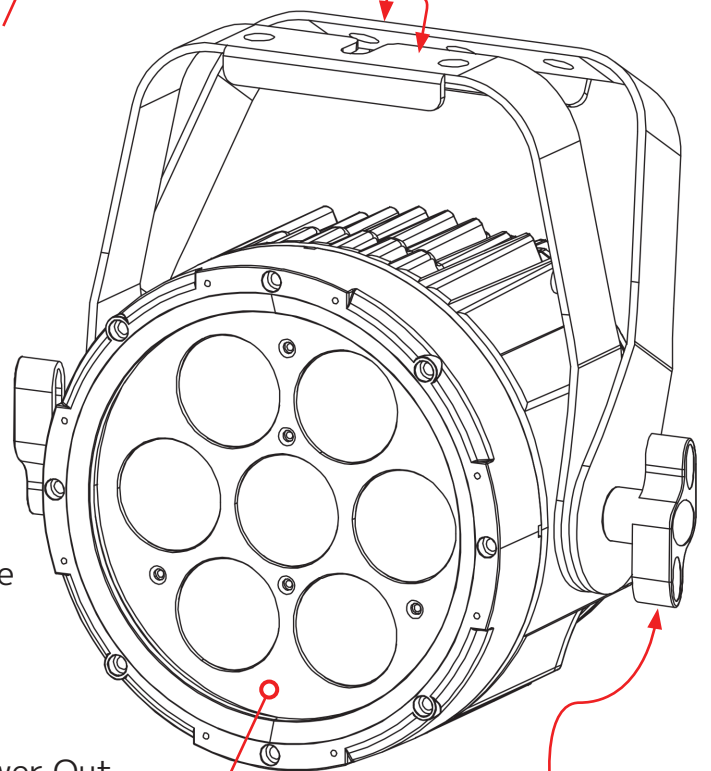
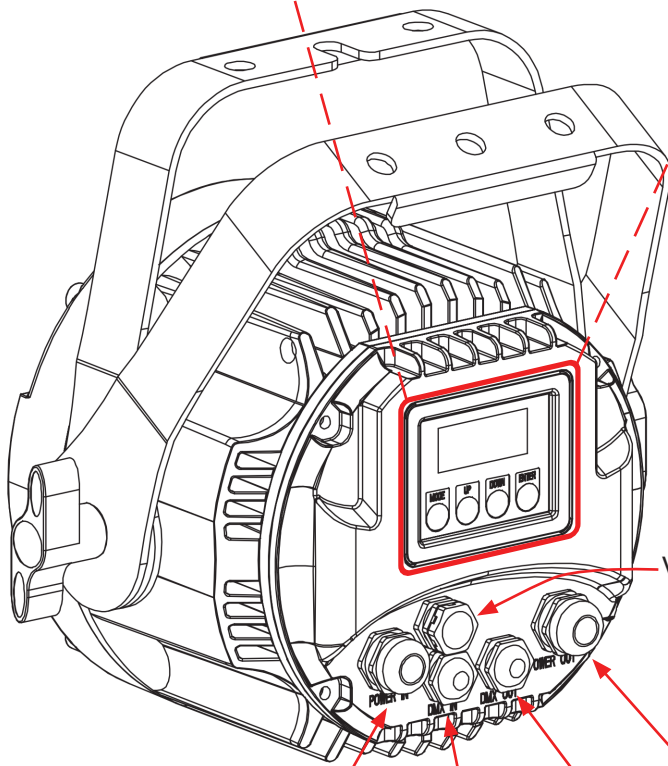

Valve
Power Out
DMX OUT
POWER IN
DMX IN

Lens
"S" Knobs to tighten
Brackets/Yokes

TORQUE SETTINGS FOR SCREWS



The hex-head screws holding either the panels or the base **MUST** be tightened with a torque wrench (not included). **TORQUE SETTING = 11 lbf-in. (12.7kgf-cm)***

*** lbf-in = Pound Force Inches | kgf-cm = Kilogram Force Centimeters**



CAUTION! DO NOT OVER TORQUE SCREWS AS THIS CAN CAUSE LEAKAGE ISSUES!

TO CONFIRM THE IP65 INTEGRITY AFTER A LAMP REPLACEMENT, TEST FIXTURE USING THE ELATION IP TESTER. CONTACT ELATION SERVICE FOR MORE DETAILS.



INSTALLATION GUIDELINES



FLAMMABLE MATERIAL WARNING

Keep fixture minimum 5.0 feet (1.5m) away from flammable materials and/or pyrotechnics.



ELECTRICAL CONNECTIONS

A qualified electrician should be used for all electrical connections and/or installations.



USE CAUTION WHEN POWER LINKING OTHER MODEL FIXTURES AS THE POWER CONSUMPTION OF OTHER MODEL FIXTURES MAY EXCEED THE MAX POWER OUTPUT ON THIS FIXTURE. CHECK SILK SCREEN FOR MAX AMPS.



**MINIMUM DISTANCE TO OBJECTS/SURFACES
MUST BE 1.6 FOOT (0.5 METERS)**



**MINIMUM DISTANCE OF INFLAMMABLE MATERIALS
FROM THE SURFACE 1.6 FEET (0.5 METER)**



MAXIMUM AMBIENT TEMPERATURE 113°F (45°C)



DO NOT INSTALL THE FIXTURE IF YOU ARE NOT QUALIFIED TO DO SO!

Fixture **MUST** be installed following all local, national, and country commercial electrical and construction codes and regulations.

Before rigging/mounting the fixture to any metal truss/structure or placing the fixture on any surface, a professional equipment installer **MUST** be consulted to determine if the metal truss/structure or surface is properly certified to safely hold the combined weight of the fixture, clamps, cables, and accessories.

Overhead rigging requires extensive experience, including, amongst others, calculating working load limits, installation material being used, and periodic safety inspection of all installation material and the fixture. If you lack these qualifications, do not attempt the installation yourself. Improper installation can result in bodily injury.

Fixture ambient operating temperature range is **14° to 113°F. (-10° to 45°C)**

Do not use the fixture under or above this temperature.

Fixture should be installed in areas outside walking paths, seating areas, or away from areas where unauthorized personnel might reach the fixture by hand.

NEVER stand directly below the fixture when rigging, removing or servicing.

Overhead fixture installation must always be secured with a secondary safety attachment, such as an appropriately rated safety cable.

Allow approximately 10 minutes for the fixture to cool down before serving.

INSTALLATION GUIDELINES

MOUNTING THE FIXTURE ON A TRUSS USING CLAMP

When mounting the fixture to a truss, be sure to secure an appropriately rated professional grade rigging clamp (not included) to the closed dual yokes using an M10 screw fitted through the center hole of the closed dual yokes. The dual yokes of the fixture provides a rigging point for a **SAFETY CABLE** (not included). Be sure to only use one of the designated rigging points for the safety cable and never secure a safety cable to a carrying handle.

SAFETY CABLE

ALWAYS ATTACH AN APPROPRIATELY RATED SAFETY CABLE WHENEVER INSTALLING THIS FIXTURE IN A SUSPENDED ENVIRONMENT TO ENSURE THE FIXTURE WILL NOT FALL IF THE CLAMP FAILS.

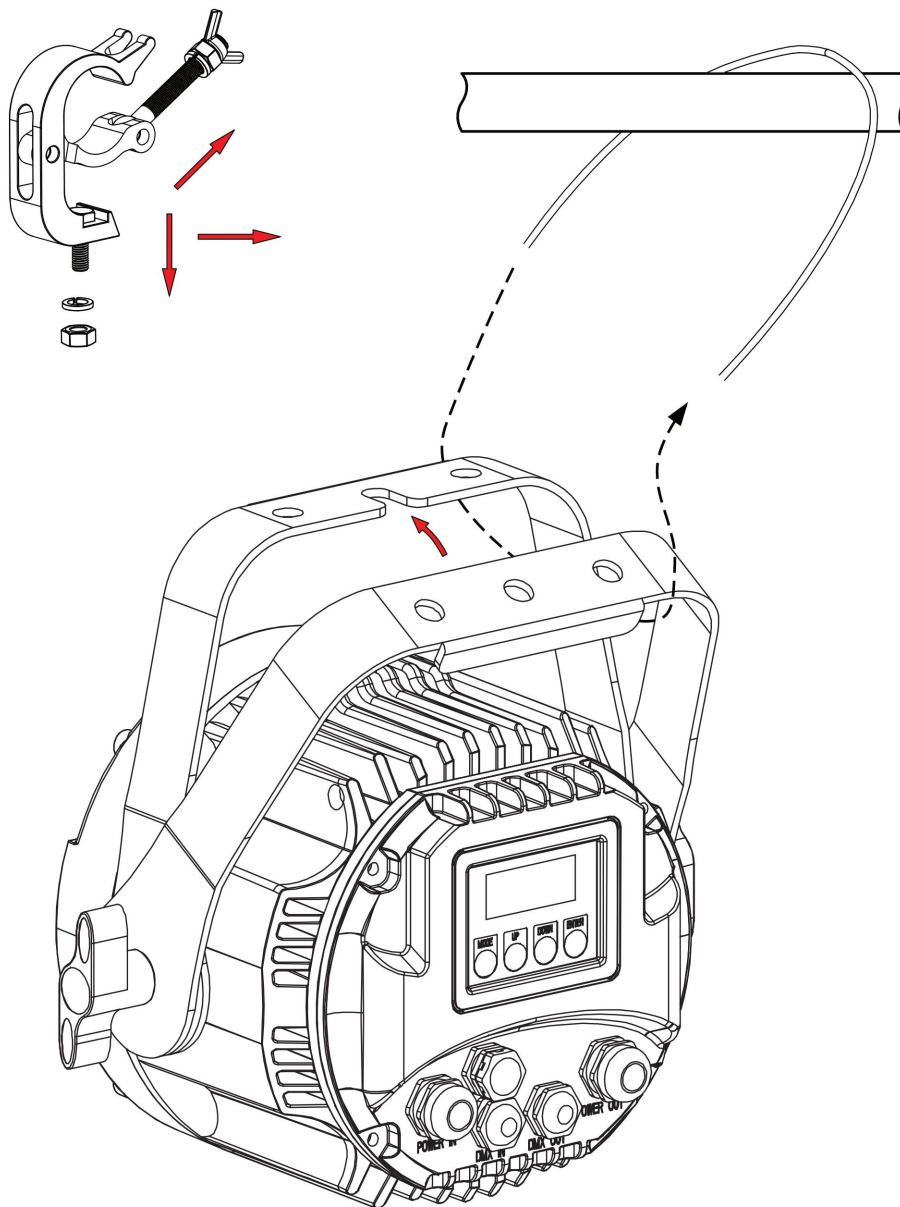

INSTALLATION GUIDELINES

RIGGING

Overhead rigging requires extensive experience, including among others calculating working load limits, installation material being used, and periodic safety inspection of all installation material and the fixture. If you lack these qualifications, do not attempt the installation yourself. Improper installation can result in bodily injury.

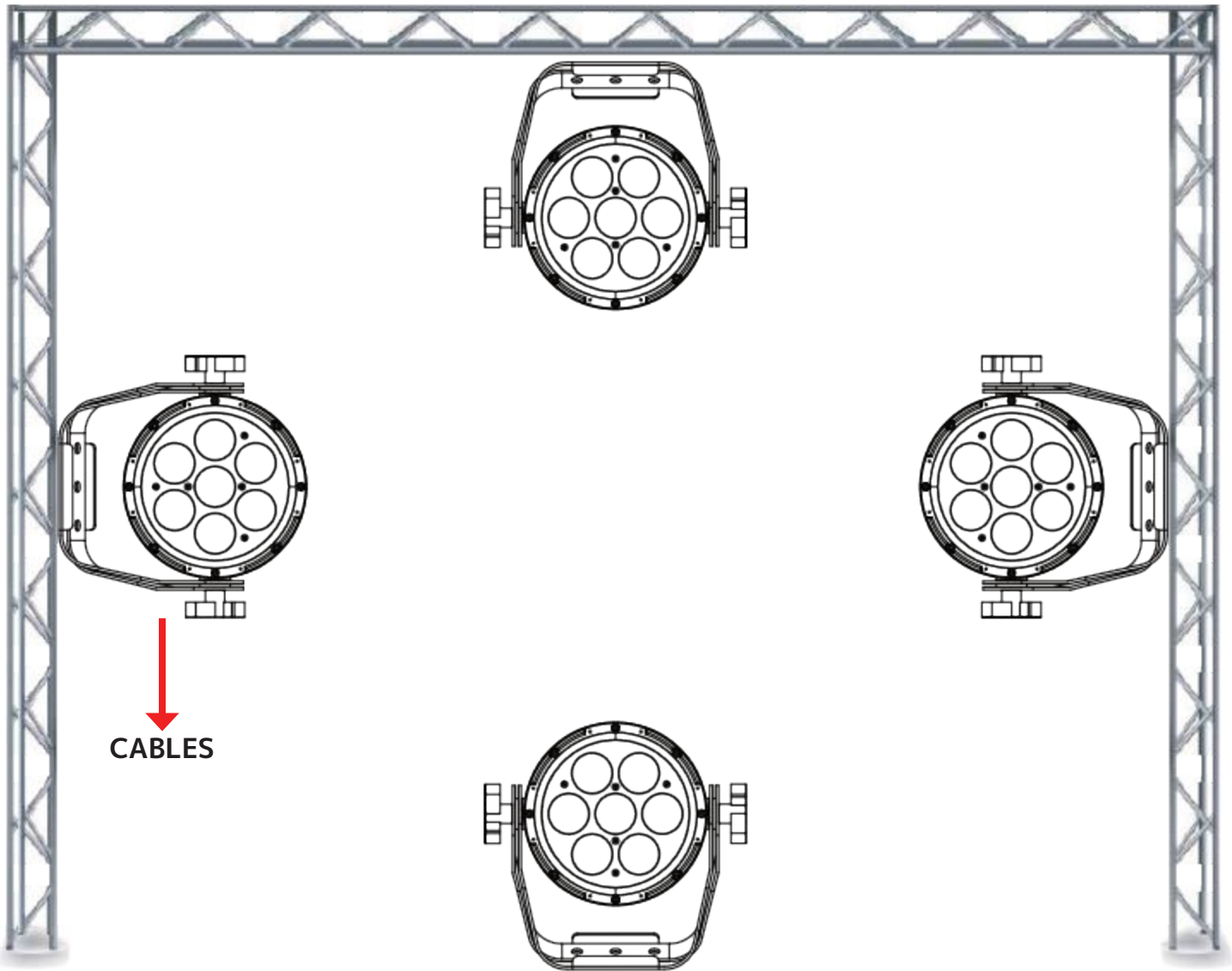

POWER AND DATA CABLES



TO MAINTAIN THE IP65 RATING INTEGRITY OF THE FIXTURE, ALL CABLES MUST BE RUN TOWARDS THE GROUND TO PREVENT WATER ACCUMULATION AROUND THE CONNECTIONS.

DMX SETUP

DMX-512

DMX is short for Digital Multiplex. This is a universal protocol used by most lighting and controller manufactures as a form of communication between intelligent fixtures and controllers. DMX allows all makes and models of different manufactures to be linked together and operate from a single controller. This is possible as long as all the fixtures and the controller are DMX compliant. A DMX controller sends the DMX data instructions to the fixture allowing the user to control the different aspects of an intelligent light. DMX data is sent out as serial data that travels from fixture to fixture via data "IN" and data "OUT" XLR terminals located on the fixtures (most controllers will only have output jacks).

DMX LINKING

To ensure proper DMX data transmission, always use the SIXPAR™ series IP rated DMX cables listed in the OPTIONAL ACCESSORIES section at the end of this manual. When using several DMX fixtures try to use the shortest cable path possible. Never split a DMX line with a "Y" style connector. The order in which the fixtures are connected in a DMX line does not influence the DMX addressing. For example; a fixture assigned a starting DMX address of 1 may be placed anywhere in the DMX chain, at the beginning, at the end, or anywhere in the middle. The DMX controller knows to send data assigned to address 1 to that fixture no matter where it is located in the DMX chain. The SIXPAR 100IP™ can be controlled via DMX-512 protocol and the DMX address is set via the control menu.

DMX Cable REQUIREMENTS (For DMX and Primary/Secondary Operation)

Your fixture and your DMX controller require a standard 3pin or 5pin XLR connector for data input and data output. Also, remember that a DMX line must be daisy chained and cannot be split.

DMX-512 CONTROLLER CONNECTION

Connect the provided XLR cable to the female XLR output of your controller and the other side to the male XLR input of the SIXPAR 100IP™. The diagram below illustrates a typical DMX-512 connection when the fixture is in the 12 Channel Mode. You can chain multiple panels together through serial linking. Always be sure daisy chain your in and out data connections, never split or "Y" your DMX connections.

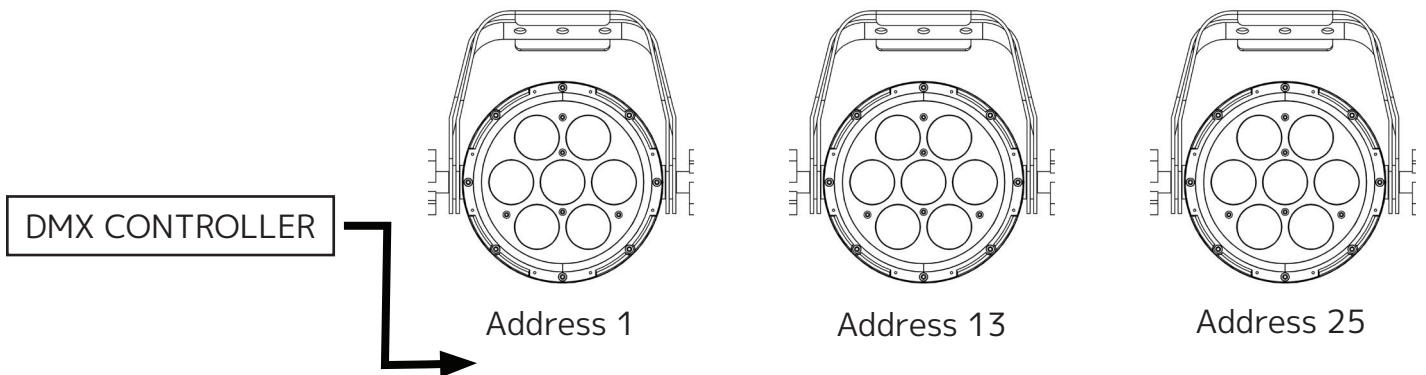

DMX-512 CONNECTION WITH DMX TERMINATOR

A DMX terminator should be used in all DMX lines especially in longer runs. The use of a terminator may avoid erratic behavior in your DMX line. A terminator is a 120 ohm 1/4 watt resistor that is connected between pins 2 and 3 of a male XLR connector (DATA + and DATA -). This fixture is inserted in the female XLR connector of the last fixture in your daisy chain to terminate the line. Using a line terminator will decrease the possibilities of erratic behavior. Use the SIXPAR™ DMX Terminator End Cap listed in the OPTIONAL ACCESSORIES section at the end of this manual.

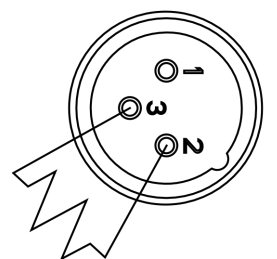

DMX SETUP

DMX ADDRESSING

All fixtures should be given a DMX starting address when using a DMX controller, so the correct fixture responds to the correct control signal. This digital starting address is the channel number from which the fixture starts to “listen” to the digital control information sent out from the DMX controller. The allocation of this starting DMX address is achieved by setting the correct DMX address on the digital display located on the back of the fixture.

The same starting address can be set for all fixtures or a group of fixtures, or set different address for each individual fixture. Be advised that setting all fixtures to the same DMX address will subsequently control all fixtures in the same fashion, in other words, changing the settings of one channel will affect all the fixtures simultaneously.

If a different DMX address is set for each fixture, each unit will start to “listen” to the channel number you have set, based on the quantity of control channels (DMX channels) of each fixture. That means changing the settings of one channel will only affect the selected fixture.

In the case of the SIXPAR 100IP™, when in the 12 Channel Mode you should set the starting DMX address of the first unit to 1, the second unit to 13 (1 + 12), the third unit to 25 (13 + 12), and so on.

Note: During start-up the SIXPAR 100IP™ will automatically detect whether a DMX data signal is being received or not. If the fixture is not receiving a DMX signal please check the following:

- The 3pin or 5pin XLR input plug (cable with DMX signal from controller) is not connected or is not inserted completely into the DMX input jack of the fixture.
- The DMX controller is switched off or defective.
- The DMX cable or connector is defective.
- A DMX terminator has been inserted into the last fixture in your DMX chain.

SYSTEM MENU

ON-BOARD SYSTEM MENU

The **SIXPAR 100IP™** comes with an easy to navigate system menu. The next sections will cover how to access each menu function.

LCD CONTROL PANEL DISPLAY

The (4) button control panel (see image below) located on back of the fixture allows you to access the main menu and make all necessary adjustments to the **SIXPAR 100IP™**.

During normal operation, pressing the **MODE** button will navigate through the different function menus. Once you reach a desired menu, press the **ENTER** button to select that menu. The variable field that can be adjusted within the selected menu will begin to flash. Using the **UP** or **DOWN** buttons, adjust the field until the desired value is displayed. For example, the **CHANNEL CH:** menu variable field can be set to **06, 07, 08,** or **12**. Pressing the **ENTER** button once will confirm your selected value. Exit at any time without making any adjustments by pressing the **MODE** button.



INFORMATION DISPLAYED DURING INITIAL POWER ON

When the fixture is initially powered **ON**, the display shows the following information:



*Fixture Software Version (≥)

LCD CONTROL PANEL LOCKOUT

When the **Display ON** menu is set to **OFF1**, the LCD display will turn OFF after 30 seconds and the (4) button Control Panel will be **LOCKED**. To unlock the (4) button LCD control panel follow these steps:

1. When locked, the display will show: **LOCKED*******
2. Press **UP**, then the display will change to: **LOCKED****** (one * disappears)
3. Press **DOWN**, then the display will change to: **LOCKED***** (two * disappear)
4. Press **UP**, then the display will change to: **LOCKED**** (three * disappear)
5. Press **DOWN**, then the display will change to: **LOCKED*** (4 * disappear)
6. Press **ENTER**, then the display will change to **LOCKED** and then become unlocked

SYSTEM MENU

ELATION SIXPAR 100IP		
Supports Software Versions: ≥ 1.3		
MAIN MENU	OPTIONS / VALUES (Default Settings in BOLD)	DESCRIPTION
Channel	CH: 06, 07, 08, 12	DMX Channel Mode
DMX Mode	ADDR: 001 ~ 512	DMX Address Setting
Secondary Mode	SECONDARY MODE	Set Fixture A secondary Unit
Display On	ON	LCD Display Always ON
	OFF	LCD Display OFF after 30 Seconds
	OFF1	LCD Display OFF after 30 Seconds and LOCKED
Internal Programs	1.MANUAL	Manual Color Adjustment
	R00-99	Adjust RED Brightness (00-99)
	G00-99	Adjust GREEN Brightness (00-99)
	B00-99	Adjust BLUE Brightness (00-99)
	W00-99	Adjust WHITE Brightness (00-99)
	A00-99	Adjust AMBER Brightness (00-99)
	U00-99	Adjust UV Brightness (00-99)
	S00-99	Adjust STROBE SPEED 00 SLOW (0.1Hz) - 99 FAST (20Hz)
	2.CHANGE	30 Color Chase Macro
	SP01-99	Adjust SPEED 01 SLOW - 99 FAST
	S00-99	Adjust STROBE SPEED 00 SLOW (0.1Hz) - 99 FAST (20Hz)
	3.CHANG6	6 Color Chase Macro
	SP01-99	Adjust SPEED 01 SLOW - 99 FAST
	S00-99	Adjust STROBE SPEED 00 SLOW (0.1Hz) - 99 FAST (20Hz)
	4.FADE	Color Fade Macro
	SP01-99	Adjust SPEED 01 SLOW 99 - FAST
S00-99	Adjust STROBE SPEED 00 SLOW (0.1Hz) - 99 FAST (20Hz)	
DimCurve	Standard, Stage, TV, Architec, Theatre	Set Dimming Curve
No DMX	Blackout	No Output
	Hold	Hold Last Setting
	Fade	Fade

DIMMER MODE

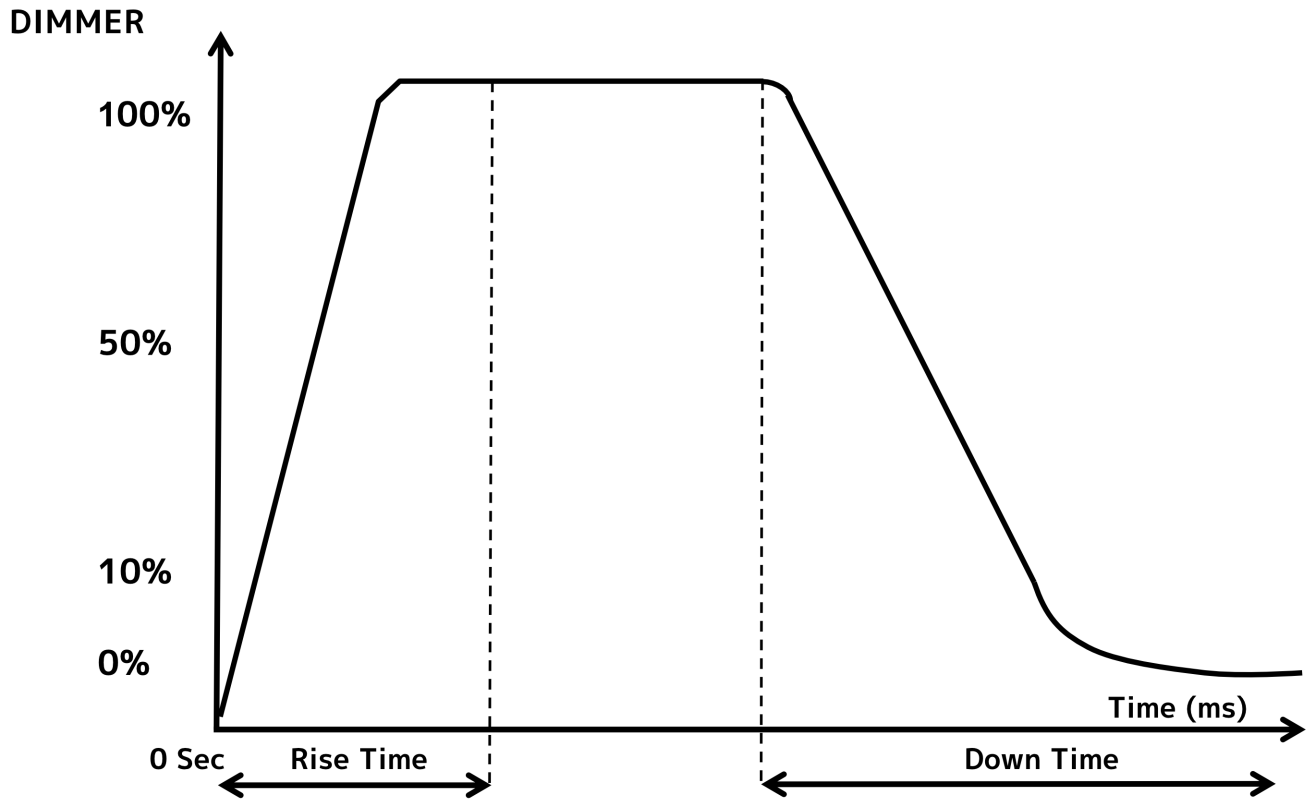

Dimming Curve Ramp Effect	0 sec Fade Time		1 sec Fade Time	
	Rise Time (ms)	Down Time (ms)	Rise Time (ms)	Down Time (ms)
Standard (default)	0	0	0	0
Stage	780	1100	1540	1660
TV	1180	1520	1860	1940
Architectural	1380	1730	2040	2120
Theatre	1580	1940	2230	2280

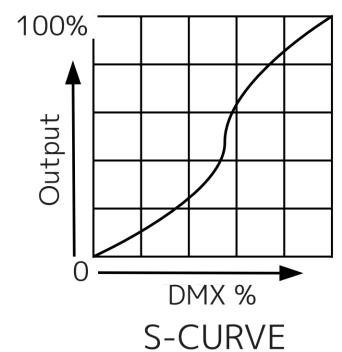
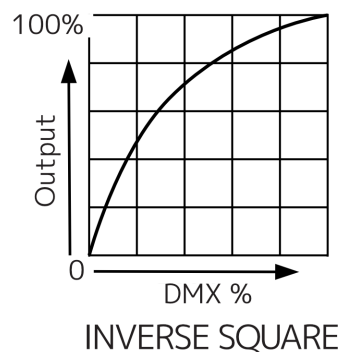
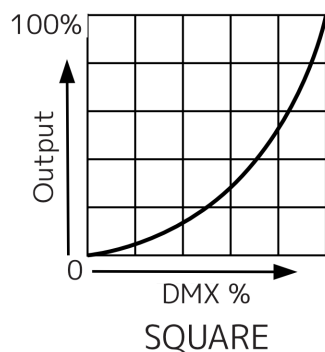
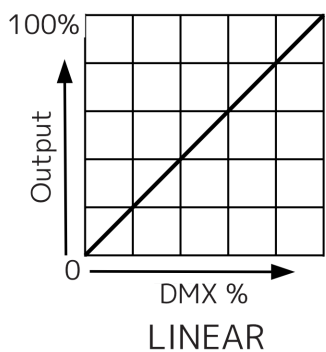

DMX TRAITS: CHANNEL FUNCTIONS & VALUES

ELATION SIXPAR 100IP					
DMX Channel Values / Functions					
Supports Software Versions: ≥ 1.0					
Features subject to change without notice					
MODE/CHANNEL				VALUE	FUNCTION
6CH	7CH	8CH	12CH		
1	1	1	1	0-255	Red: Red (0-100%)
2	2	2	2	0-255	Green: Green (0-100%)
3	3	3	3	0-255	Blue: Blue (0-100%)
4	4	4	4	0-255	White: White (0-100%)
5	5	5	5	0-255	Amber: Amber (0-100%)
6	6	6	6	0-255	U.V.: U.V. (0-100%)
	7	7	7	0-255	Master Dimmer: Dimmer (0-100%)
		8	8	0-31	STROBE: LED OFF (NO STROBE)
				32-95	Strobe Effect SLOW to FAST
				96-127	LED ON (NO STROBE)
				128-159	Strobe Pulse Effect in Sequence SLOW to FAST
				160-191	LED ON (NO STROBE)
				192-223	Random Strobe Effect SLOW to FAST
				224-255	LED ON (NO STROBE)
			9	0-3	COLOR MACROS OFF
				4-7	RED
				8-11	GREEN
				12-15	BLUE
				16-19	WHITE
				20-23	AMBER
				24-27	UV
				28-31	RED + GREEN
				32-35	RED + BLUE
				36-39	RED + BLUE
				40-43	RED + AMBER
				44-47	RED + UV
				48-51	GREEN + BLUE
				52-55	GREEN + WHITE
				56-59	GREEN + AMBER
				60-63	GREEN + UV
				64-67	BLUE + WHITE
				68-71	BLUE + AMBER
				72-75	BLUE + UV
				76-79	WHITE + AMBER
				80-83	WHITE + UV
				84-87	AMBER + UV
				88-91	RED + GREEN + BLUE
				92-95	RED + GREEN + WHITE
				96-99	RED + GREEN + AMBER
				100-103	RED + GREEN + UV
				104-107	RED + BLUE + WHITE
				108-111	RED + BLUE + AMBER
				112-115	RED + BLUE + UV

ELATION SIXPAR 100IP					
DMX Channel Values / Functions					
Supports Software Versions: ≥ 1.0					
Features subject to change without notice					
MODE/CHANNEL				VALUE	FUNCTION
6CH	7CH	8CH	12CH		
			9		
				116-119	RED + WHITE + AMBER
				120-123	RED + WHITE + UV
				124-127	RED + AMBER + UV
				128-131	GREEN + BLUE + WHITE
				132-135	GREEN + BLUE + AMBER
				136-139	GREEN + BLUE + UV
				140-143	GREEN + WHITE + AMBER
				144-147	GREEN + WHITE + UV
				148-151	GREEN + AMBER + UV
				152-155	BLUE + WHITE + AMBER
				156-159	BLUE + WHITE + UV
				160-163	BLUE + AMBER + UV
				164-167	WHITE + AMBER + UV
				168-171	RED + GREEN + BLUE + WHITE
				172-175	RED + GREEN + BLUE + AMBER
				176-179	RED + GREEN + BLUE + UV
				180-183	RED + GREEN + WHITE + AMBER
				184-187	RED + GREEN + WHITE + UV
				188-191	RED + GREEN + AMBER + UV
				192-195	RED + BLUE + WHITE + AMBER
				196-199	RED + BLUE + WHITE + UV
				200-203	RED + BLUE + AMBER + UV
				204-207	RED + WHITE + AMBER + UV
				208-211	GREEN + BLUE + WHITE + AMBER
				212-215	GREEN + BLUE + WHITE + UV
				216-219	GREEN + BLUE + AMBER + UV
				220-223	GREEN + WHITE + AMBER + UV
				224-227	BLUE + WHITE + AMBER + UV
				228-231	RED + GREEN + BLUE + WHITE + AMBER
			232-235	RED + GREEN + BLUE + WHITE + UV	
			236-239	RED + GREEN + BLUE + AMBER + UV	
			240-243	RED + GREEN + WHITE + AMBER + UV	
			244-247	RED + BLUE + WHITE + AMBER + UV	
			248-251	GREEN + BLUE + WHITE + AMBER + UV	
			252-255	RED + GREEN + BLUE + WHITE + AMBER + UV	
				COLOR CHASE MACROS	
			0-20	NO FUNCTION	
			21-40	30 COLOR CHASE	
			41-60	6 COLOR CHASE	
			61-80	COLOR FADE CHASE	
			81-255	NO FUNCTION	
				COLOR CHASE MACROS SPEED	
			0-255	CHASE SPEED OF CHANNEL 10-SLOW TO FAST	
				DIMMING MODES	
			0-20	STANDARD	
			21-40	STAGE	
			41-60	TV	
			61-80	ARCHITECTURAL	
			81-100	THEATER	
			101-255	NO FUNCTION	

MAINTENANCE GUIDELINES



DISCONNECT POWER BEFORE PERFORMING ANY MAINTENANCE!

CLEANING

Frequent cleaning is recommended to insure proper function, optimized light output, and an extended life. The frequency of cleaning depends on the environment in which the fixture operates: damp, smoky or particularly dirty environments can cause greater accumulation of dirt on the fixture's optics. Clean the external lens surface at least every 20 days with a soft cloth to avoid dirt/debris accumulation.

NEVER use alcohol, solvents, or ammonia-based cleaners.

MAINTENANCE

Regular inspections are recommended to insure proper function and extended life.

There are no user serviceable parts inside this fixture, please refer all other service issues to an authorized Elation service technician. Should you need any spare parts, please order genuine parts from an authorized Elation dealer.

Please refer to the following points during routine inspections:

- A detailed electric check by an approved electrical engineer every three months, to make sure the circuit contacts are in good condition and prevent overheating.
- Be sure all screws and fasteners are securely tightened at all times. Loose screws may fall out during normal operation resulting in damage or injury as larger parts could fall.
- Check for any deformations on the housing, color lenses, rigging hardware and rigging points (ceiling, suspension, trussing). Deformations in the housing could allow for dust to enter into the fixture. Damaged rigging points or unsecured rigging could cause the fixture to fall and seriously injure a person(s).
- Electric power supply cables must not show any damage, material fatigue or sediments.
- NEVER remove the ground prong from the power cable.

SPECIFICATIONS

SOURCE

(7) 12W 6-in-1 RGBAW+UV LEDs
100,000 Hour Average LED Life*

*LED Life may vary depending on several factors including but not limited to:
Environmental Conditions, Power/Voltage, Usage Patterns (On-Off Cycling), Control, and Dimming.

PHOTOMETRIC DATA

12,850 LUX 1,194 FC @3.3' (1m) (15° Full ON)

EFFECTS

Electronic Strobe
Color and Chase Macros
Electronic Dimming: 0% - 100%
5 Variable Dimming Curve Modes

CONTROL / CONNECTIONS

(4) DMX Channel Modes (6 / 7 / 8 / 12)
(4) Button Touch Control Panel
LCD Menu Display
IP DMX In/Out
IP Power In/Out
With Wired Digital Communication Network

SIZE / WEIGHT

Length: 10.1" (257mm)
Width: 6.2" (158mm)
Vertical Height: 9.6" (243mm)
Weight: 9.5 lbs. (4.3 kg)

ELECTRICAL / THERMAL

AC 110-250V - 50/60Hz
89W Max Power Consumption
Power Linking: 12pcs @110V / 25pcs @240V
5°F to 113°F (-15°C to 45°C)
UV Wavelength: 395nm

APPROVALS / RATINGS

CE | cETLus | IP65



Intertek
4010765

INCLUDED ITEMS

Male Edison to IP Female Power Cable 6,6 ft. (2m) (16AWG)
Male 5pin XLR to IP Female DMX Input Cable 3.3 ft (1m) 24AWG)
Female 5pin XLR to IP Male DMX Output Cable 3.3 ft (1m) 24AWG)

FIRMWARE UPDATES

Current Version: V1.17
Click [HERE](#) for software updates

Specifications and documentation subject to change without notice.

PHOTOMETRIC DATA

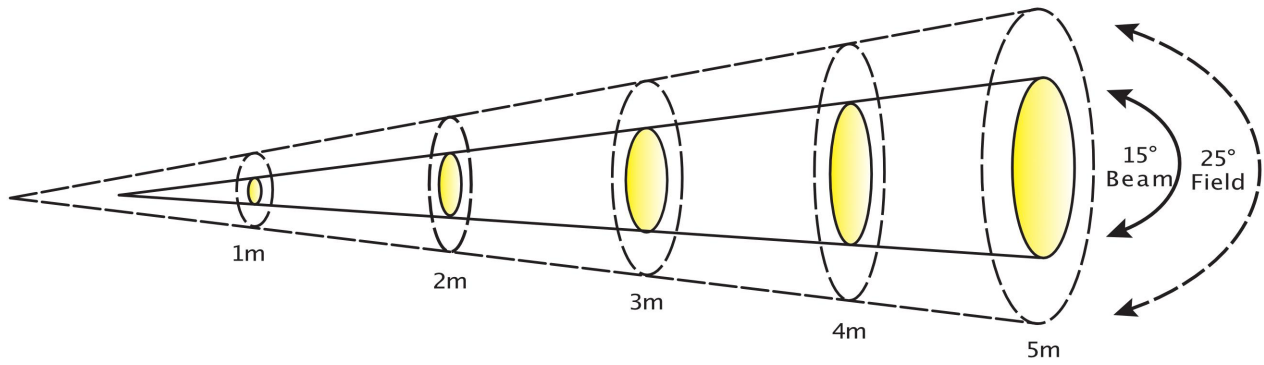

Distance	m	ft	m	ft	m	ft	m	ft	m	ft
15° Beam Diameter	0.35	1.1	0.54	1.8	0.8	2.6	1.05	3.4	1.32	4.3
25° Field Diameter	0.45	1.5	0.88	2.9	1.33	4.4	1.77	5.8	2.21	7.3
	lux	fc	lux	fc	lux	fc	lux	fc	lux	fc
RED LEDs	2,160	201	545	51	249	23	116	11	83	8
GREEN LEDs	4,180	388	1,055	98	484	45	235	22	174	16
BLUE LEDs	4,670	434	1,205	112	545	51	284	26	190	18
WHITE LEDs	4,160	386	1,012	94	487	45	271	25	174	16
AMBER LEDs	1,590	148	376	35	172	16	93	9	61	6
UV LEDs	985	92	247	23	175	16	63	6	43	4
FULL ON	12,850	1194	2,880	268	1,401	130	848	79	571	53

DIMENSIONS

*Drawings not to scale. Specifications and improvements in the design of this unit and this manual are subject to change without notice.

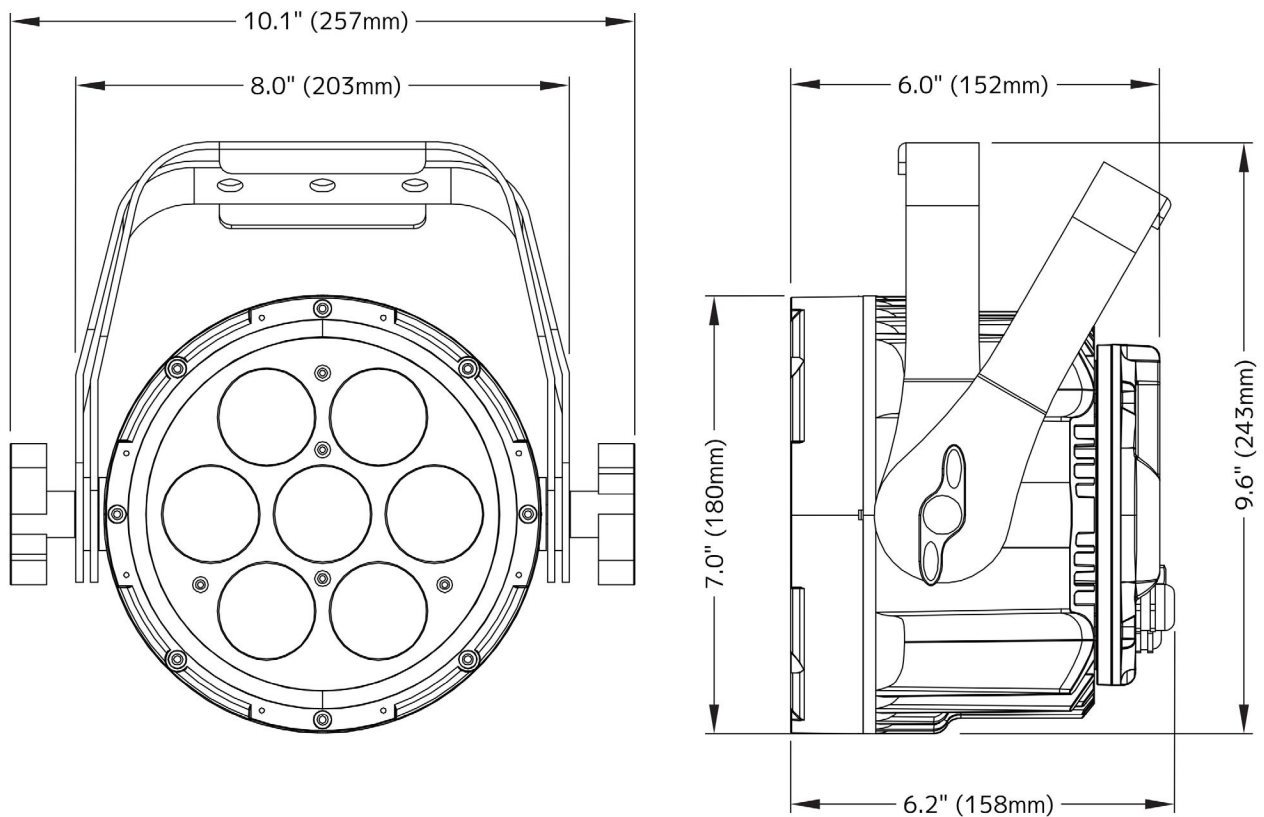

OPTIONAL ACCESSORIES

ORDER CODE	ITEM
SIXPAR100/GFH	Gel Frame Holder Kit
SIXPAR/BD100	Barn Door
NOTE: Gel Frame Holder Kit required to attach Barn Door. (Sold separately)	
SIXPAR/2MDLC	6.6 ft. (2m) IP Data Link Cable
SIXPAR/2MPLC	6.6 ft. (2m) IP Power Link Cable
SIXPAR/3MDLC	9.8 ft. (3m) IP Data Link Cable
SIXPAR/3MDLC	9.8 ft. (3m) IP Power Link Cable
SIXPAR/5MDLC *SPECIAL ORDER*	16.4 ft. (5m) IP Data Link Cable
SIXPAR/5MPLC *SPECIAL ORDER*	16.4 ft. (5m) IP Power Link Cable
SIXPAR/10MDLC *SPECIAL ORDER*	32.8 ft. (10m) IP Data Link Cable
SIXPAR/10MPLC *SPECIAL ORDER*	32.8 ft. (10m) IP Power Link Cable
SIXPAR/20MDLC *SPECIAL ORDER*	65.6 ft. (20m) IP Data Link Cable
SIXPAR/20MPLC *SPECIAL ORDER*	65.6 ft. (20m) IP Power Link Cable
SIXPAR/DIAC	Data IN IP Adapter Cable
SIXPAR/DOAC	Data OUT IP Adapter Cable
SIXPAR/PIAC	Power IN IP Adapter Cable
SIXPAR/POAC	Power OUT IP Adapter Cable
SIXPAR/TERMINATOR	DMX Terminator End Cap

FCC STATEMENT

This device complies with Part 15 of the FCC Rules. Operation is subject to the following two conditions: (1) this device may not cause harmful interference, and (2) this device must accept any interference received, including interference that may cause undesired operation.

FCC RADIO FREQUENCY INTERFERENCE WARNINGS & INSTRUCTIONS

This product has been tested and found to comply with the limits as per Part 15 of the FCC Rules. These limits are designed to provide reasonable protection against harmful interference in a residential installation. This device uses and can radiate radio frequency energy and, if not installed and used in accordance with the included instructions, may cause harmful interference to radio communications. However, there is no guarantee that interference will not occur in a particular installation. If this device does cause harmful interference to radio or television reception, which can be determined by turning the device off and on, the user is encouraged to try to correct the interference by one or more of the following methods:

- Reorient or relocate the device.
- increase the separation between the device and the receiver.
- Connect the device to an electrical outlet on a circuit different from which the radio receiver is connected.
- Consult the dealer or an experienced radio/TV technician for help.

Energy Saving Matters (EuP 2009/125/EC)

Saving electric energy is a key to help protecting the environment. Please turn off all electrical products when they are not in use. To avoid power consumption in idle mode, disconnect all electrical equipment from power when not in use. Thank you!



