

※ Thank you for selecting the Tracer BP MPPT solar charge controller. Please read this manual carefully before using the product and pay attention to the safety information.
 ※ Do not install this product in humid, salt spray, corrosion, greasy, flammable, explosive, dust accumulative, or other severe environments.

MPPT Solar Charge Controller

1. Safety Information

- Read all the instructions before installation.
- DO NOT disassemble or attempt to repair the controller.
- Install external fast-acting fuse or breaker as required.
- Disconnect the solar module and fast-acting fuse/ breakers near to battery before installing or moving the controller.
- Power connections must remain tight to avoid excessive heating from a loose connection.
- Only batteries that comply with the controller's parameters can be charged.
- Battery connection may be wired to one battery or a bank of batteries.
- Risk of electric shock, the PV and load may produce high voltages when the controller is running.

2. Overview

The Tracer BP solar charge controller adopts the advanced Maximum Power Point Tracking charging technology. Increase the system charging efficiency, yet lower down the system cost. The controller supports various batteries, for example, sealed, gel, flooded, and lithium battery. Users can view and modify the operational status and parameters. It can be widely used in a solar home system, traffic signal, solar street light, solar garden lamp, etc. The features are listed below:

- Adopt high-quality components of ST, IR, and Infineon to ensure product lifespan
- Wider working environment temperature
- Apply to lead-acid battery and lithium battery
- Lithium battery self-activating and low-temperature protection function
- The maximum conversion efficiency of 98%
- Advanced Maximum Power Point Tracking (MPPT) technology, with tracking efficiency no less than 99%
- Accurately recognizing and tracking of multiple power points
- PV power limitation function
- Monitoring and setting parameters via Mobile APP, PC software
- Adopt standard Modbus communication protocol for RS485 bus connections to get better communication protocol compatibility
- Connecting the IoT (Internet of Things) module and Cloud Server monitoring software to realize remote monitoring
- The RS485 connector can provide a power supply
- Aluminum housing for better cooling
- Real-time energy statistics function
- IP68 waterproof degree

3. Product Features

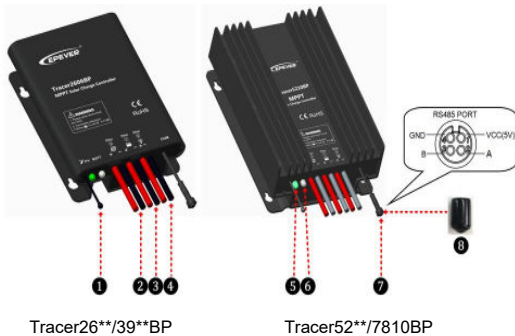

① Temperature Sensor ^①	⑤ Charging Status LED indicator
② PV Positive and Negative Wires	⑥ Battery Status LED indicator
③ Battery Positive and Negative Wires	⑦ RS485 waterproof port ^②
④ Load Positive and Negative Wires	⑧ Waterproof cap(Included)

- (1) If the temperature sensor is short-circuited or damaged, the controller shall be charging or discharging at the default temperature of 25°C.
- (2) The port can provide a DC power supply of 5VDC/150mA and own the short circuit function.

	When the RS485 communication port is not working, the waterproof cap must be installed to prevent water from getting in.
--	--

4. Wiring

● Connection sequence

- 1) Connect components to the controller in the sequence ① > ② > ③ as shown below and pay much attention to the "+" and "-". Please don't insert the fast-acting fuse or turn on the breaker during the installation. When disconnecting the system, the order

will be reserved.

- 2) After powering the controller, the battery LED indicator on the controller shall flash green. If it's not green, please refer to Chapter 10 Troubleshooting.

- 3) Connect a fast-acting fuse in series through battery positive (+) in the circuit. The battery fast-acting fuse must be 1.25 to 2 times the rated current. The installed distance is within 150mm.

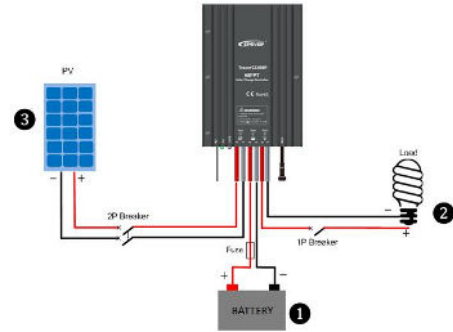

● Load self-test function

The load is automatically turned ON after powering on the controller for 10s. After the load keeps ON status for 10s, the controller restores to the set working mode.

5. LED Indicators

Indicator	Color	Status	Instruction
PV	Green	On Solid	PV connection normal but low voltage (irradiance) from PV, no charging
		OFF	No PV voltage (night time) or PV connection problem
		Slowly Flashing (1Hz)	In charging
		Fast Flashing (4Hz)	PV overvoltage
BATT	Green	On Solid	Battery is normal
		Slowly Flashing (1Hz)	Battery charges full
		Fast Flashing (4Hz)	Battery overvoltage
	Red	On Solid	Battery under voltage
		Fast Flashing (4Hz)	Battery over-discharged Battery overheating Lithium battery low temperature
Charging indicator (green) and battery indicator (orange) flashing simultaneously			System voltage error※

※When the battery type is a lithium battery, the controller does not recognize the system voltage automatically.

6. Load Working Mode

- 1) Manual Mode(Default ON)
- 2) Light ON/OFF

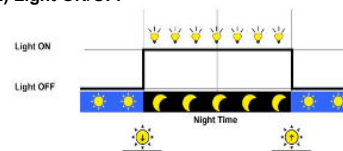

Turn-On voltage (Adjustable):
5V (12Vsystem), delay 10min.

Turn-Off voltage (Adjustable):
6V (12Vsystem), delay 10min.

Note: 24V system voltage×2

- 3) Light ON+ Timer

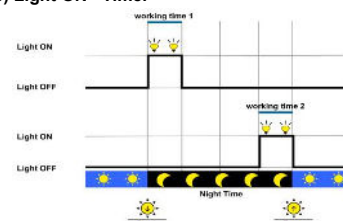

- 4) Real-time Control

Control the load ON/OFF time by setting a real-time clock.



In the mode of Light ON/OFF and Light ON/Timer, the Load is turned on after 10Min. Delay.

7. Optional Accessories and Software

- 1) EPEVER cloud-PC website: <https://hncloud.epsolarpv.com/>
- 2) EPEVER cloud-APP download:



※ For detail of EPEVER cloud, please refer to the Solar Guardian user manual. MT52 and eLOG01-G3 are not waterproof. If used outdoors, please ensure proper waterproofing and dust protection. And MT52 cannot set the relevant parameters of the lithium battery and load mode.



8. Protection

• PV Over Current

The controller will limit the battery charging current to the Maximum Battery Current rating. Therefore an oversized solar array will not operate at peak power.

• PV Short Circuit

When PV short circuit is powered on or the PV input is a short circuit on low-power, the controller will stop charging. Clear it to resume regular operation.



WARNING

The controller may be damaged when the PV input is a short circuit on a high-power.

• PV Reverse Polarity

The PV can be reversely connected with a controller when:

- ✓ Only the PV is connected with the controller;
- ✓ The battery is positively connected, and the PV's open-circuit voltage is lower than 85V (This requirement is only for Tracer26/39/5210BP).



WARNING

The controller will be damaged when the PV array straight polarity and the PV array's actual operating power is 1.5 times greater than the rated charge power!

• Battery Reverse Polarity

When the PV is not connecting or connecting reversed, complete protection against reverse battery polarity, correct the wire connection to resume regular operation.



WARNING

The controller will be damaged when the PV connection is correct, and the battery connection reversed!

• Battery Over Voltage

When the battery voltage reaches the set point of Over Voltage Disconnect Voltage, the controller will stop charging the battery to protect the battery from being overcharged to break down.

• Battery Over Discharge

When the battery voltage reaches the Low Voltage Disconnect Voltage, the controller will stop discharging the battery to protect the battery from being over-discharged to break down.

• Battery Overheating

The controller detects the environment temperature through the external temperature sensor. If the environment temperature exceeds 65°C, the controller will automatically start the overheating protection to stop working and recover below 55°C.

• Lithium battery Low Temperature

The temperature sensor is less than the low-temperature value, and the Lithium battery stops charging/discharging. It is higher than the low-temperature value, and the Lithium battery starts charging/discharging.

• Load Overload

If the load current exceeds the maximum load current rating 1.05 times, the controller

will disconnect the load. Overloading must be cleared up by reducing the load and restarting the controller.

• Load Short Circuit

The load will be switched off when the load short circuit (≥ 4 times rated current) happens.

The controller will automatically attempt to reconnect the load 5 times. Suppose short circuit protection still exists after the controller's 5 times attempts. In that case, the user has to clear the short circuit, restart the controller or wait for one night-day cycle (night time > 3 hours).

• Temperature sensor break down

Suppose the temperature sensor is short-circuited or damaged. In that case, the controller shall be charging or discharging at the default temperature of 25°C to prevent the battery damaged from overcharging or over-discharged.

• High Voltage Transients

The controller is protected against small high voltage transients. In lightning-prone areas, additional external suppression is recommended.

10. Troubleshooting

Faults	Possible reasons	Troubleshooting
LED Charging indicator turn off during daytime when sunshine falls on PV modules properly	PV array disconnection	Confirm that PV and battery wire connections are correct and tight.
No LED indicator	Battery voltage may be less than 8.5V	Measure battery voltage with the multi-meter. Min.8.5V can start up the controller.
Battery LED indicator green fast Flashing	Battery over voltage	Check if the battery voltage is higher than OVD, and disconnect the PV.
Battery LED indicator red	Battery over-discharged	When the battery voltage is restored to or above the LVR point (low voltage reconnect voltage), the load will recover.
Battery LED indicator red flashing	Battery Overheating	The controller will automatically turn the system off. But while the temperature decline to be below 50°C, the controller will resume.
Load is not output	Load Overload ^①	①Please reduce the number of electric equipment. ②Restart the controller. ③wait for one night-day cycle (night time >3 hours).
	Load Short Circuit ^①	①Check carefully loads connection, clear the fault. ②Restart the controller. ③wait for one night-day cycle (night time >3 hours).

①When it is overload or short circuit, the load has 5 times auto-recovery output function, which each time delay respectively 5s, 10s, 15s, 20s, 25s.

11. Disclaimer

This warranty does not apply under the following conditions:

- Damage from improper use or use in an unsuitable environment.
- PV or load current, voltage, or power exceeds the rated value of the controller.
- The controller's working temperature exceeds the limit working environment temperature.
- User disassembly or attempted to repair the controller without permission.
- The controller is damaged due to natural elements such as lightning.
- The controller is damaged during transportation and shipment.

9. Technical Specifications

Item	Model	Tracer2606BP	Tracer3906BP	Tracer5206BP	Tracer2610BP	Tracer3910BP	Tracer5210BP	Tracer7810BP
Nominal system voltage		12/24VDC Auto (Lithium battery cannot automatically identify system voltage)						
Battery input voltage range		8.5 to 32VDC						
Rated charge/discharge current		10A	15A	20A	10A	15A	20A	30A
Rated charge power		130W/12V; 260W/24V	200W/12V; 400W/24V	260W/12V; 520W/24V	130W/12V; 260W/24V	200W/12V; 400W/24V	260W/12V; 520W/24V	390W/12V; 780W/24V
Max. PV open circuit voltage		60V (at minimum operating environment temperature) 46V (at 25°C environment temperature)			100V (at minimum operating environment temperature) 92V (at 25°C environment temperature)			
MPP Voltage range		(Battery voltage+2V) to 36V						
Battery Type		Lead-acid battery: Sealed(Default)/Gel/Flooded/User; Lithium battery: LiFePO4/Li-NiCoMn/User						
Lead-acid	Equalize Charging Voltage	Sealed: 14.6V, Gel: No, Flooded: 14.8V, User: 9-17V (X2/24V)						
	Boost Charging Voltage	Sealed:14.4V, Gel: 14.2V, Flooded: 14.6V, User: 9-17V (X2/24V)						
	Float Charging Voltage	Sealed/Gel/Flooded: 13.8V, User: 9-17V (X2/24V)						
	Low Voltage Reconnect Voltage	Sealed/Gel/Flooded: 12.6V, User: 9-17V (X2/24V)						
Lithium	Low Voltage Disconnect Voltage	Sealed/Gel/Flooded: 11.1V, User: 9-17V (X2/24V)						
	Boost Charging Voltage	LiFePO4: 14.5V, Li-NiCoMn: 12.5V, User: 9-17V (X2/24V)						
	Low Voltage Reconnect Voltage	LiFePO4: 12.8V, Li-NiCoMn: 10.5V, User: 9-17V (X2/24V)						
Low Voltage Disconnect Voltage	LiFePO4:1 1.1V, Li-NiCoMn: 9.3V, User: 9-17V (X2/24V)							
Self-consumption		$\leq 13mA/12V; \leq 11.5mA/24V$						
Temperature compensation coefficient		-3mV/°C/2V (Lithium battery don't have temperature compensation coefficient)						
Communication		RS485						
Environment Temperature		-40°C to +60°C						-40°C to +50°C
Enclosure		IP68						
Overall dimension		124×89×30mm	150×93.5×32.7mm	153×105×52.1mm	124×89×30mm	150×93.5×32.7mm	153×105×52.1mm	153.3×105×52.1mm
Mounting hole size		Φ3.5mm						
Mounting size		88×76mm	120×83mm	120×94mm	88×76mm	120×83mm	120×94mm	
Power cable		14AWG (2.5mm ²)		12AWG (4mm ²)	14AWG (2.5mm ²)		12AWG (4mm ²)	10AWG (6mm ²)
Net weight		0.54kg	0.74kg	1.20kg	0.54kg	0.74kg	1.20kg	1.26kg

Any changes without prior notice! Version number: V3.6