

Parts and Components

What comes in the box

Robot Vacuum

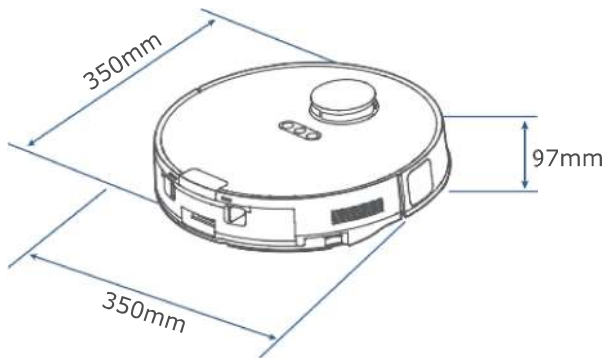

Self-Emptying Base

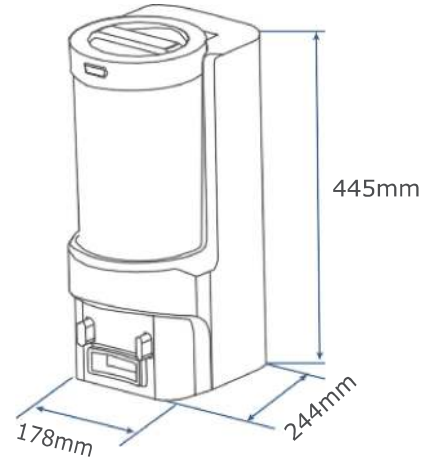

Side Brush x2

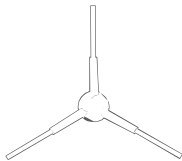

Cleaning Brush



Instruction Manual



How to identify parts of your robot

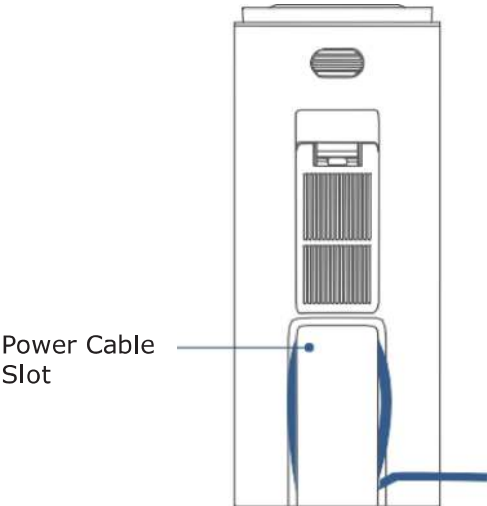
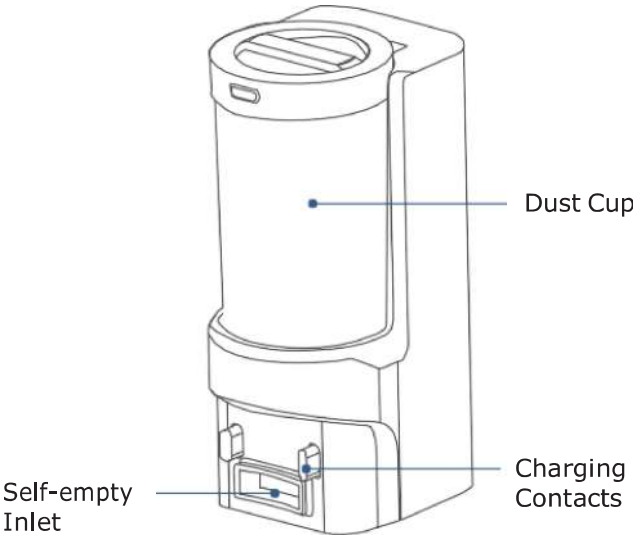
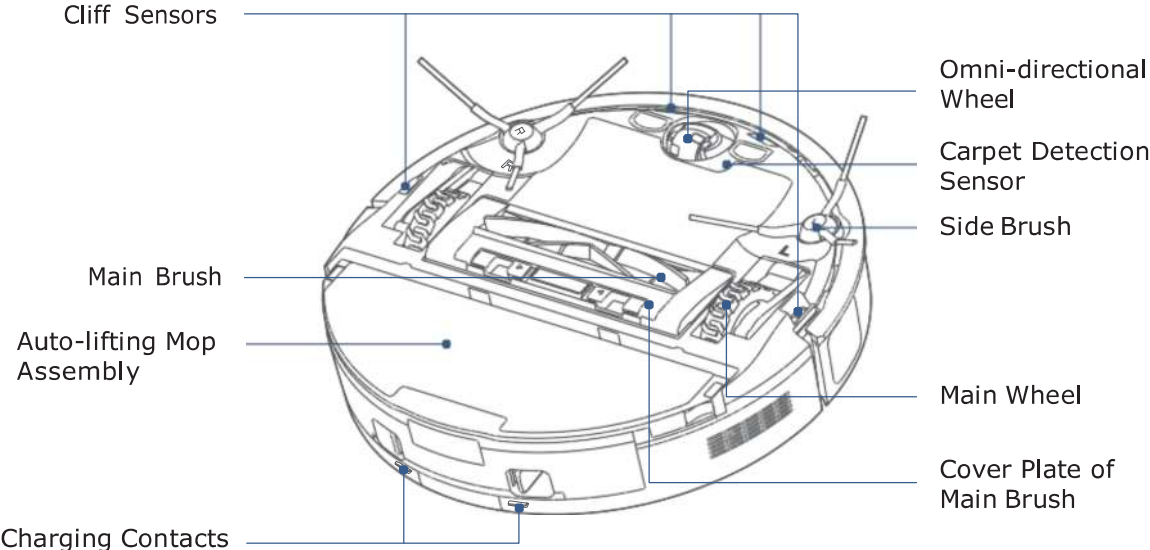
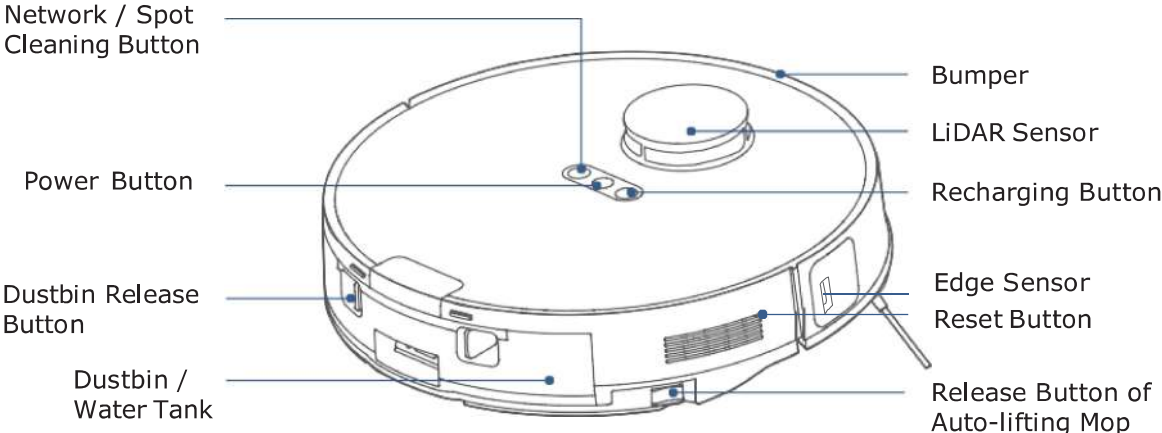

! WARNING

Remove excess clutter and cables on the floor before cleaning.

Quick Assembly

■ Installation of side brushes

Turn the main unit over. Attach the side brush to its color-matched post and press down until they fit into place.

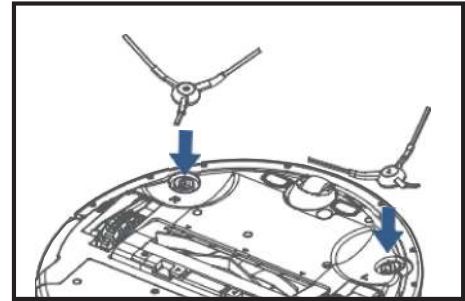

■ Filter installation

Robot comes with filter installed. Before use, ensure the filter is securely in place. If not, remove dustbin from robot, pull up lid of dustbin and make sure filter is snapped into place. Ensure dustbin lid and bottom latch are securely closed and place back dustbin onto robot. When using the mopping function, open the tank lid, fill the water tank with cold water, and securely close the lid.

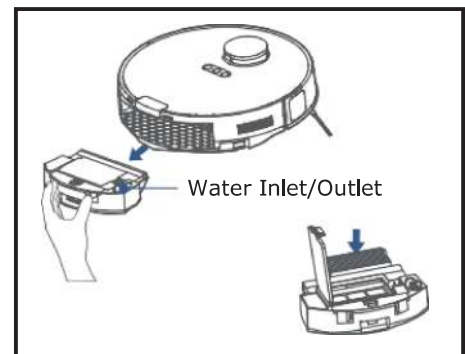

■ Setting up self-emptying base

1. Place the self-emptying base flat against the wall on a level surface. If there is any charging base for other robot vacuum cleaners in the room, please put it away before use of our self-emptying base to avoid mismatching.
2. Place the self-emptying base in an area covered with wireless network signal to ensure stable network connection of the robot and proper function of the App. Store the excess cords into the slot at the back of the charging base to avoid affecting the proper function of the robot vacuum.
3. Plug the power plug into a power outlet.

