

Uputstvo za upotrebu (EN)

FIELDMANN FDPO 200711-E univerzalna testera



Tehnoteka je online destinacija za upoređivanje cena i karakteristika bele tehnike, potrošačke elektronike i IT uređaja kod trgovinskih lanaca i internet prodavnica u Srbiji. Naša stranica vam omogućava da istražite najnovije informacije, detaljne karakteristike i konkurentne cene proizvoda.

Posetite nas i uživajte u ekskluzivnom iskustvu pametne kupovine klikom na link:

<https://tehnoteka.rs/p/fieldmann-fdpo-200711-e-univerzalna-testera-akcija-cena/>



FDPO 200711-E

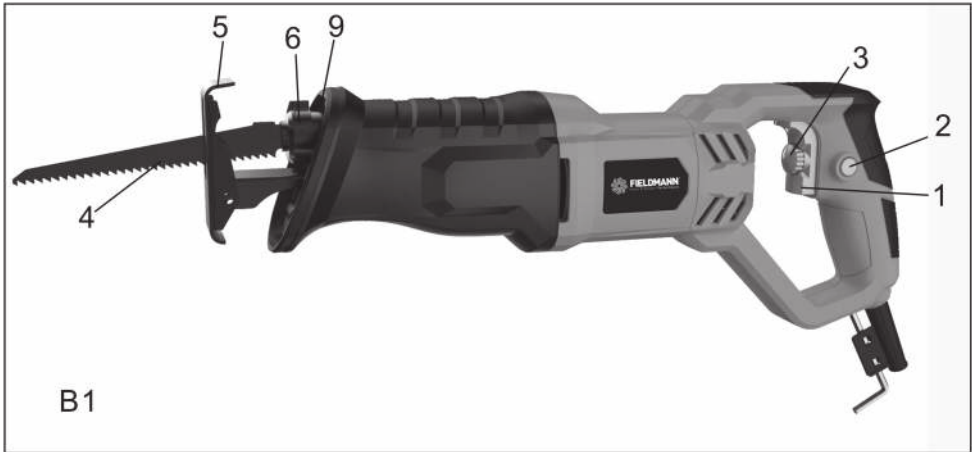

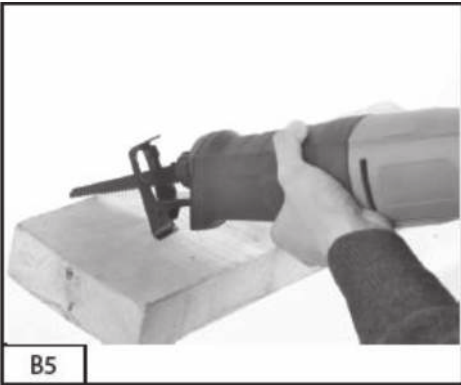
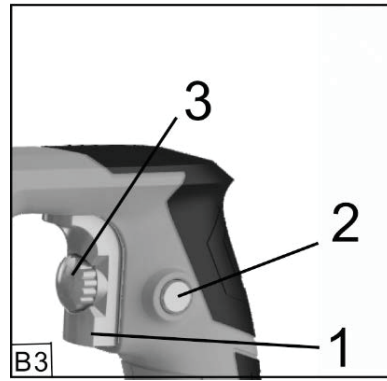
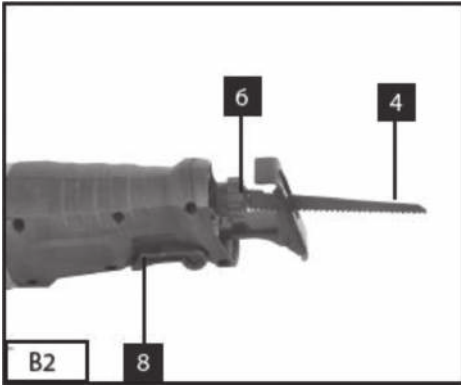

Electrical Reciprocating Saw

USER'S MANUAL

Thank you for purchasing this Electrical Reciprocating Saw. Before you start using it, please carefully read this user's manual and save it for possible future use.

CONTENTS



1. GENERAL SAFETY INSTRUCTIONS	6
2. SYMBOLS	7
3. MACHINE DESCRIPTION AND ITEMS DELIVERED.....	8
4. GENERAL SAFETY INSTRUCTIONS.....	9
5. BEFORE STARTING THE EQUIPMENT.....	12
6. OPERATIONAL	13
7. TECHNICAL DATA.....	14
8. CLEANING AND MAINTENANCE.....	14
9. DISPOSAL	15

1. GENERAL SAFETY INSTRUCTIONS

WARNING!

Carefully read the instruction manual before use.

Important safety warnings

-  Unpack the product carefully and be sure not to throw away any part of the package before having found all components of the product.
-  Keep the product in a dry place out of reach of children.
-  Read all cautions and instructions. The failure to adhere to warning cautions and instructions may result in an accident, fire and/or a serious injury.

Packaging

The product is placed in a package preventing damage during transport. This package is a raw material therefore it can be handed-over for recycling.

Instructions for use

Before beginning to work with the machine, read the following safety rules and instructions for use. Familiarize with operating elements and the proper use of the device. Keep the manual in a safe place for future reference.

We recommend keeping the original package including the inner packaging materials, cash voucher and guarantee card for a period of warranty at minimum.

For a case of transportation, pack the machine into the original box from the manufacturer, thus ensuring a maximum protection of the product during a possible transport (e.g. moving or sending into a service station).

Note:

If you hand the machine over to next persons, hand it over together with the manual. Adherence to the attached instructions for use is a precondition for the proper use of the machine. The operation manual includes also instructions for operation, maintenance and repairs.

The manufacturer does not take any responsibility for accidents or damages resulting from the failure to adhere to this manual.

2. SYMBOLS



The product complies with the applicable standards and regulations.



Read the Instruction Manual attentively prior to use.



Use eyes protective equipment



Use ears protective equipment

3. MACHINE DESCRIPTION AND ITEMS DELIVERED

1. On/Off switch
2. Locking button
3. Locking for speed
4. Saw blade
5. Soleplate
6. Blade holder
8. Lever to adjust the soleplate
9. LED working light

Items Delivered

Remove all contents from the box and inspect to ensure no damage was incurred during shipping, and that the items listed below are included.

- ✿ Reciprocating Saw
- ✿ 2 saw blade
- ✿ Warranty card
- ✿ EC declaration
- ✿ Instruction Manual

Should the components be missing or damaged, contact the dealer of the machine.

4. GENERAL SAFETY INSTRUCTIONS

Please read these safety instructions carefully, remember them and keep them in a safe place.

⚠ WARNING!

When using electric machinery and power tools, it is important to abide by and adhere to the following safety instructions for reasons of protection against injury caused by electric current, injury of persons and risk of starting fires. The term "power tools" used in the instructions below refers to power tools that are plugged into a power supply (by a power cord) as well as tools running on a battery pack (cordless). Keep all warnings and instructions for further use.

Work environment

- ✿ Keep the work area clean and well lit. Untidiness and dark places on the job site are usually causes of accidents. Store tools that are not used.
- ✿ Do not use power tools in an environment where there is risk of starting a fire or explosion; this refers to places where there are flammable liquids, gases or dust. Sparks form on the power tool's commutator, which can cause dust or fume ignition.
- ✿ When using power tools, unauthorized persons, especially children, should be denied entry to the job site! In case you are interrupted, you can lose control of the current activity. In any case, do not leave the power tool without supervision. Prevent animals from approaching the equipment.

Electrical safety

- ✿ The power tool's power plug must correspond to the power outlet. Never alter the plug in any way. If the tool's plug has a safety peg, never use an adapter of any kind. Undamaged plugs and corresponding outlets prevent the risk of injury by electric current. If the power cord is damaged, it must be replaced by a new power cord that can be obtained from an authorized service centre or the importer.
- ✿ Avoid bodily contact with grounded items, e.g. piping, radiators, kitchen ranges and refrigerators. The risk of injury by electric current is greater if your body is connected to the ground.
- ✿ Do not expose power tools to rain, moisture or dampness. Never touch power tools with wet hands. Never wash power tools with running water and never submerge them into water.
- ✿ Do not use the power cord for any other purpose than originally intended. Never carry or pull the power tools by the power cord. Do not pull the plug out of the outlet by pulling on the cord. Avoid mechanical damage to the power cord by sharp or hot objects.
- ✿ Power tools were manufactured exclusively for the AC power supply. Always check if the electrical voltage corresponds to the data printed on the tool's serial number label.
- ✿ Never work with a tool that has a damaged power cord or plug, or that has fallen on the ground and is damaged in any way.
- ✿ In the case of using an extension cord, always check that its technical parameters correspond to the data printed on the tool's serial number label. If the power tool is used outdoors, use an extension cord that is appropriate for exterior use. When using an extension cable drum, the cord must be unwound to prevent the cord from overheating.
- ✿ If the power tool is used in moist areas or outdoors, it is permitted to use it only if it is plugged into an electric circuit with a residual current device ≤ 30 mA. Using a circuit with an RCD lowers the risk of injury by electric current.

- ✿ Grasp hand power tools at the designated isolated grip areas because, during operation, one may come into contact with the cutting or drilling fittings with a hidden conductor or with the power cord.

Personal safety

- ✿ When using a power tool, be careful and alert, pay special attention to the activity you are doing. Concentrate on your work. Do not work with power tools if you are tired or if you are under the influence of drugs, alcohol or medication. When using power tools, even a momentary lapse in attentiveness can lead to severe personal injury. Do not eat, drink or smoke while working with power tools.
- ✿ Use protective gear. Always use eye protection. Use protective gear corresponding to the type of work you are doing. Protective gear such as respirators, safety shoes with antiskid treatment, head protection or ear protection, used in accordance with working conditions, lower the risk of personal injury.
- ✿ Avoid unintentional operation of tools. Do not carry tools that are plugged into the electric grid with your finger on the switch or release trigger. Before connecting the tool to a power supply, make sure that the switch or release trigger are in the "off" position. Carrying tools with your finger on the switch or plugging the tool into an outlet with the switch in the "on" position can cause serious injury.
- ✿ Before turning tools on, remove all adjustment wrenches and tools. The adjustment wrench or tool that stays connected to the rotating part of the power tool can cause personal injury.
- ✿ Always stand firmly and keep your balance. Work only in places that you can reach safely. Never overestimate your own strength. Do not use power tools if you are tired.
- ✿ Dress appropriately. Use working clothes. Do not wear loose clothing or jewellery. Make sure that your hair, clothing, gloves or other body parts do not come overly close to rotating or heated parts of the power tool.
- ✿ Connect the equipment to the dust exhaust. If the tool offers the possibility to connect equipment for capturing dust or dust suction, make sure that it is properly connected and used. Using this equipment can reduce danger resulting from dust.
- ✿ Firmly fasten the workpiece. Use a carpenter's clamp or vice to secure the piece you will be cutting.
- ✿ Do not use power tools if you are under the influence of alcohol, drugs, medication or other narcotics or addictive substances.
- ✿ This equipment is not intended to be used by persons with limited physical, sensory or mental abilities (including children) or persons with insufficient experience and knowledge, unless they are supervised or received instructions to use the equipment from a person responsible for his/her safety. Children must be supervised in order to ensure that they are not playing with the equipment.

Using power tools and their maintenance

- ✿ Always disconnect the power tool from the electric grid if there is any problem during work, before every cleaning or maintenance, during every shift and after finishing work! Never work with power tools if they are damaged in any way.
- ✿ If the tool starts emitting abnormal noises or odours, immediately stop working.
- ✿ Do not overload power tools. The power tool will function better and more safely if it operates at speeds for which it was designed. Use correct tools that are designated for the given activity. The correct tool works better and more safely.
- ✿ Do not use power tools that cannot be turned on safely and cannot be turned on and off with a control switch. Using this type of tool is dangerous. Faulty switches must be repaired at a certified service centre.
- ✿ Disconnect the tool from the power supply before you start setting, changing accessories or maintenance. This measure will prevent the risk of accidental start-up.

- ✿ Store unused power tools so that they are out of the reach of children and unauthorized persons. Power tools in the hands of inexperienced users can be dangerous. Store power tools in a dry and safe place.
- ✿ Keep power tools in good condition. Regularly check the setting of moving parts and their movability. Check if the protective cover or other parts that can limit the safe functioning of the power tool are not damaged. If the tool is damaged, ensure its proper repair before the next use. Many injuries are caused by poorly maintained power tools.
- ✿ Keep cutting tools sharp and clean. Properly maintained and sharpened tools make work easier, limit the risk of injury and work with them is much more easily controlled. Using other accessories than those listed in the instruction manual can cause damage to the tool and can cause injury.
- ✿ Use power tools, accessories, work tools, etc. in accordance with these instructions and in a way that is described for the specific power tool and with regard to the given working conditions and the type of job. Using tools for other purposes than those intended can lead to dangerous situations.

Service

- ✿ Do not change parts of the tool, do not perform repairs on your own and do not interfere with the tool's construction in any way. Leave tool repairs to qualified persons.
- ✿ Each repair or product modification performed without our company's permission is inadmissible (it can cause injury or harm to the user).
- ✿ Always leave tools to be repaired in a certified service centre. Use only original or recommended spare parts. This will ensure your and your tool's safety.

5. BEFORE STARTING THE EQUIPMENT

Before you connect the equipment to the mains supply make sure that the data on the rating plate are identical to the mains data.

Always pull the power plug before making adjustments to the equipment.

Changing the saw blade (B2)

- ✿ Always switch off and unplug the reciprocating saw before working on the machine or changing the saw blade.
- ✿ Turn the ring on the blade holder (6) as shown in Fig. 2 until the blade lets itself be slipped into the slot of the blade holder (6).
- ✿ When you now let go of the ring again, the ring should return to its starting position.
- ✿ If this fails to happen, try turning the ring by hand into its starting position.
- ✿ Pull on the blade to check whether it sits tightly in the holder.

Adjusting the soleplate (B2)

- ✿ Loosen the lever(8), pull or push the soleplate to a desired position.
- ✿ Push the lever(8) back.
- ✿ Check that the soleplate is secure.

Electronic speed control (B3)

- ✿ By increasing pressing the on / off switch (1), the speed increases.
- ✿ With the speed selection (3) in the ON / OFF switch (1), the desired speed can be selected.

Turn toward +: higher speed

Turn towards -: lower speed

6. OPERATIONAL

ON/OFF switch (B3)

To switch on:

Press the ON/OFF switch (1)

To switch off:

Release the ON/OFF switch (1)

Locking button (B3)

You can lock the ON/OFF switch (1) using the locking button (2) when the equipment is in operation. To lock it, press the ON/OFF switch. To switch off the equipment briefly hold down the ON/OFF switch.

Use as a jigsaw (B5)

Place the reciprocating saw on the material to be cut as shown in Fig. 5. Switch on the reciprocating saw and push it along against the material to be cut. Adapt your cutting speed to the material.

LED lamp

The LED light (9) makes it possible to illuminate working in unfavorable lighting conditions. The LED light (9) lights up automatically as soon as you put the plug in the socket.

Replacing the power cable

If the power cable for this equipment is damaged, it must be replaced by the manufacturer or its aftersales service or similarly trained personnel to avoid danger.

7. TECHNICAL DATA

Mains voltage	AC 230-240V, 50/60Hz
Power input	710 W
Stroke speed	0–2800 min ⁻¹
Cutting depth, wood	115 mm
Cutting depth, iron	5 mm
Cutting depth, metal pipe	60 mm
Sound pressure level	$L_{pA} = 82.1 \text{ dB (A)}$, $K_{pA} = 5 \text{ dB (A)}$
Sound power level	$L_{wA} = 93.1 \text{ dB (A)}$, $K_{wA} = 5 \text{ dB (A)}$
Vibration level	$a_h, B = 22.5 \text{ m/s}^2$, $K = 1.5 \text{ m/s}^2$

8. CLEANING AND MAINTENANCE

Always pull out the mains power plug before starting any cleaning work.

Cleaning

- ✿ Keep all safety devices, air vents and the motor housing free of dirt and dust as far as possible.
- ✿ Wipe the equipment with a clean cloth or blow it with compressed air at low pressure.
- ✿ We recommend that you clean the device immediately each time you have finished using it.
- ✿ Clean the equipment regularly with a moist cloth and some soft soap. Do not use cleaning agents or solvents; these could attack the plastic parts of the equipment. Ensure that no water can seep into the device.

Carbon brushes

In case of excessive sparking, have the carbon brushes checked only by a qualified electrician.

IMPORTANT

The carbon brushes should not be replaced by anyone but a qualified electrician.

Maintenance

There are no parts inside the equipment which require additional maintenance.

9. DISPOSAL

INSTRUCTIONS AND INFORMATION ON DISPOSING OF USED PACKAGING MATERIALS

Dispose of used packaging material at a site designated for waste in your municipality.



The appliance and its accessories are manufactured from various materials, e.g. metal and plastic.

Take damaged parts to a recycling centre. Inquire at the relevant government department.



This appliance meets all the basic requirements of the EU directives.

Changes in the text, design and technical specifications may be made without prior notice and we reserve the right to make these changes.

User manual in the original language.

Ovaj dokument je originalno proizveden i objavljen od strane proizvođača, brenda Fieldmann, i preuzet je sa njihove zvanične stranice. S obzirom na ovu činjenicu, Tehnoteka ističe da ne preuzima odgovornost za tačnost, celovitost ili pouzdanost informacija, podataka, mišljenja, saveta ili izjava sadržanih u ovom dokumentu.

Napominjemo da Tehnoteka nema ovlašćenje da izvrši bilo kakve izmene ili dopune na ovom dokumentu, stoga nismo odgovorni za eventualne greške, propuste ili netačnosti koje se mogu naći unutar njega. Tehnoteka ne odgovara za štetu nanесenu korisnicima pri upotrebi netačnih podataka. Ukoliko imate dodatna pitanja o proizvodu, ljubazno vas molimo da kontaktirate direktno proizvođača kako biste dobili sve detaljne informacije.

Za najnovije informacije o ceni, dostupnim akcijama i tehničkim karakteristikama proizvoda koji se pominje u ovom dokumentu, molimo posetite našu stranicu klikom na sledeći link:

<https://tehnoteka.rs/p/fieldmann-fdpo-200711-e-univerzalna-testera-akcija-cena/>