



FIELDMANN®
Home & Garden Performance



FDK 200802 - E

English	9
Čeština	26
Slovenčina	44
Magyarul	66
Polski	87

1

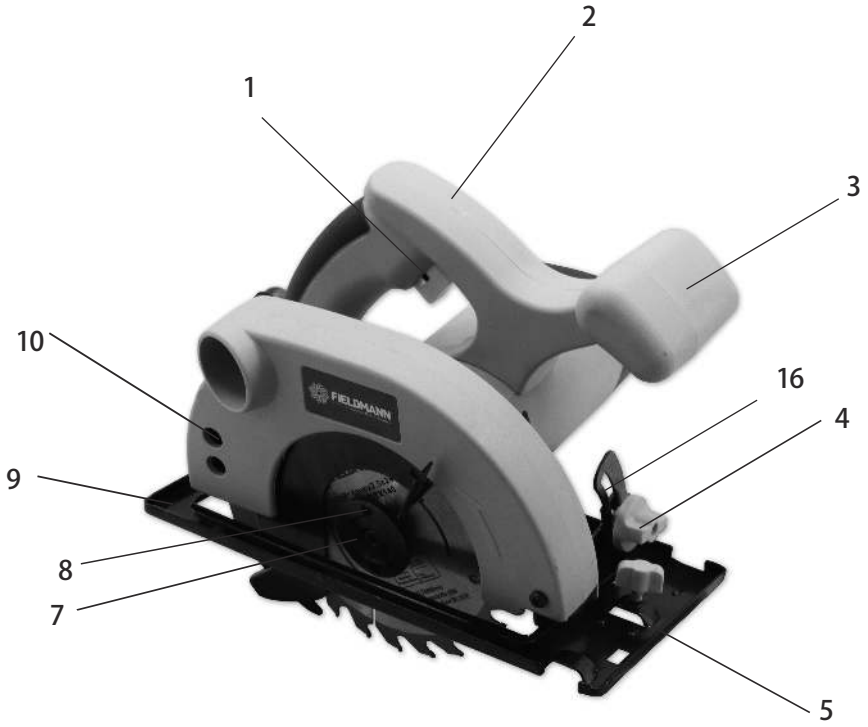

2

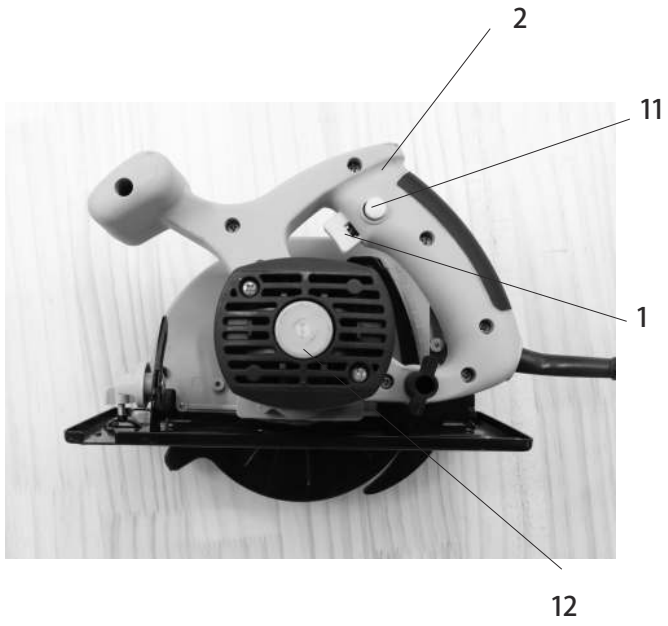

3



4

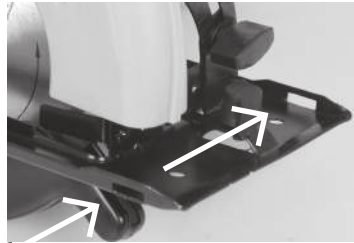

5



6



7

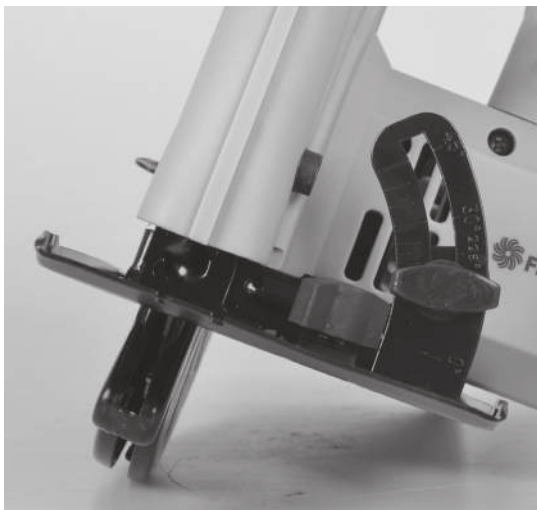

8



Electrical Circular Saw

INSTRUCTION MANUAL

Thank you for your purchase of the electrical circular saw. For your personal safety, read and understand the Instruction Manual before using. Keep the Instruction Manual in a safe place for future reference.

TABLE OF CONTENTS

1. GENERAL SAFETY REGULATIONS	10
2. GENERAL SAFETY INSTRUCTIONS	13
3. SYMBOLS AND PICTOGRAMS	14
4. MACHINE DESCRIPTION AND PACKAGE CONTENT	15
5. SAFETY INSTRUCTIONS	16
6. USE AND OPERATION	20
7. ADJUSTMENT AND OPERATION	20
8. CLEANING AND MAINTENANCE	22
9. CLEANING AND MAINTENANCE TIPS	22
10. TECHNICAL DATA	23
11. LIQUIDATION	25

GENERAL SAFETY INSTRUCTIONS

Carefully read, remember and keep these safety instructions

⚠ WARNING! In the use of electric machines and power tools, it is necessary to respect and follow the following safety instructions for the reasons of protection against electric shock, personal injury and danger of fire. The term “power tool” in the instructions below refers both to mains-operated (corded) power tool or battery-operated (cordless) power tool. Save all warnings and instructions for future reference.

Workplace

- ✿ Keep the work area clean and well lit. Cluttered or dark areas in the workplace invite accidents. Store power tools that you don't currently use.
- ✿ Do not operate power tools in environments with danger of occurrence of a fire or explosion, such as in the presence of flammable liquids, gases, or dust. Power tools create sparks which may ignite the dust or fumes.
- ✿ Keep unauthorised persons, especially children, away from the work area while operating a power tool! Distractions can cause you to lose control over the performed activity. In no event leave your power tool unattended. Keep the equipment away from animals.

Electrical Safety

- ✿ Power tool plugs must match the mains socket outlet. Never modify the plug in any way. Do not use any adapter plugs with earthed (grounded) power tools. Undamaged plugs and matching outlets will reduce risk of electric shock. Damaged or fouled supply cables increase the risk of electric shock. If the power cord is damaged, it must be replaced by a new power cord which is available at the authorised service centre or the importer.
- ✿ Avoid body contact with earthed or grounded surfaces such as pipes, radiators, cooking ranges and refrigerators. There is an increased risk of electric shock if your body is earthed or grounded.
- ✿ Do not expose power tools to rain or wet conditions. Never touch the power tool with wet hands. Never wash the power tool under running water or immerse it in water.
- ✿ Never use the supply cable for other than intended purposes. Never use the cord for carrying or pulling the power tool. Never unplug the plug from the outlet by pulling the cable. Keep electric cables away from sharp or hot objects to prevent mechanical damage.
- ✿ The power tool was designed to be powered solely by alternating electric current. Always check if the electric voltage matches the information specified in the type label of the power tool.
- ✿ Never use power tool with damaged electric cable or plug or which has been dropped or is in any way damaged.

- ✿ If an extension cord is used, always check whether its technical parameters match the information specified in the type label of the power tool. When operating a power tool outdoors, use an extension cord suitable for outdoor use. If extension drums are used, these must be rolled out to prevent overheating of the cord.
- ✿ If a power tool is operated in a damp location or outdoors, its operation is only permitted if connected to an electric circuit protected by a residual current device <math><30\text{ mA}</math>. Use of residual current device (RCD) reduces the risk of electric shock.
- ✿ Hold the power tool by insulated gripping surfaces only as the cutting or drilling tool may contact hidden wiring or its own power cord during operation.

Personal Safety

- ✿ Be careful, stay alert and watch what you are doing when operating a power tool. Concentrate on your work. Do not use a power tool while you are tired or under the influence of drugs, alcohol or medication. A moment of inattention while operating power tools may result in serious personal injury. Do not eat, drink and smoke while operating a power tool.
- ✿ Use personal protective equipment. Always wear eye protection. Use protective equipment corresponding to the type of work you are doing. Protective equipment such as dust mask, non-skid safety shoes, hard hat, or hearing protection used in accordance with the working conditions will reduce the risk of personal injury.
- ✿ Prevent unintentional starting. Do not carry the power tool while it is energised or with your finger on the switch or trigger. Ensure the switch or trigger is in the "off" position before connecting to power source. Carrying power tools with your finger on the switch or energising power tools that have the switch on may result in serious injuries.
- ✿ Remove any adjusting key or wrench before turning the power tool on. An adjusting wrench or a key left attached to a rotating part of the power tool may result in personal injury.
- ✿ Keep proper footing and balance at all times. Do not overreach. Never overestimate your own capabilities. Never use power tools while you are tired.
- ✿ Dress properly. Wear work clothes. Do not wear loose clothing or jewellery. Keep your hair, clothing, gloves and other part of your body away from moving or hot parts of the power tool.
- ✿ Connect the equipment to dust exhaustion. If the tools are provided for the connection of dust collection or exhaustion devices, ensure these are properly connected and used. Use of such devices can reduce dust-related hazards.
- ✿ Fix the work-piece tightly. Use a cabinet clamp or a cramp to fix the work-piece you are about to machine.
- ✿ Never use power tools if you are under the influence of alcohol, drugs, medication or other narcotic or addictive substances.
- ✿ This equipment is not intended for use by persons (including children) with limited physical, sensual or mental capacities or lack of experience or knowledge unless they are supervised or instructed about the use of the equipment by a person responsible for their safety. Children must be supervised to make sure they are not playing with the equipment.

Power Tool Use and Maintenance

- ✿ Always disconnect the power tool from the mains in case of any problem during the work, before cleaning the power tool or its maintenance, during each transportation and after the completion of the work! Never operate a power tool if it is damaged in any way.
- ✿ Immediately stop working if the power tool generates abnormal noise or smell.
- ✿ Do not overload the power tool. The power tool will operate better and safer if it is used at the rate for which it was designed. Use correct power tool which is intended for the given activity. The correct power tool will do the job it was designed for better and safer.
- ✿ Do not use the power tool if it cannot be safely turned on and off using the control switch. Use of such power tool is dangerous. Defective switches must be repaired by a certified service provider.
- ✿ Disconnect the tool from the power source before making any adjustments, changing accessories or maintenance. Such preventive safety measure prevents the risk of starting the power tool accidentally.
- ✿ Store idle power tools out of the reach of children and unauthorised persons. Power tools can be dangerous in the hands of untrained users. Store the power tools in a dry and safe place.
- ✿ Keep the power tool in good condition. Check the adjustment of moving parts and their mobility. Check for any damage to the protective guards or other parts which could affect safe operation of the power tool. If damaged, have the power tool properly repaired before further use. Many accidents are caused by poorly maintained power tools.
- ✿ Keep cutting tools sharp and clean. Properly maintained cutting tools with sharp cutting edges facilitate work, reduce the risk of injury and are easier to control. Use of accessories other than those specified in the instructions for use could result in damage to the power tool and cause injuries.
- ✿ Use the power tool, accessories and tool bits etc. in accordance with these instructions and in the manner intended for the particular type of power tool taking into account the working conditions and the work to be performed. Use of the power tool for purposes other than those the power tool was intended for could result in hazardous situations.

Service

- ✿ Do not replace parts of the power tool, do not make any repairs or interfere in any way with the construction of the power tool. Have your power tool repaired by qualified repair persons.
- ✿ Any repair or modification of the product without our company's authorisation is impermissible (it could cause injury or damage to the user).
- ✿ Always have your power tool repaired in a certified service centre. Use only original or recommended replacement parts. This will ensure that your safety and the safety of your power tool is maintained.

3. SYMBOLS AND PICTOGRAMS



The product complies with the applicable standards and regulations.



Read the Instruction Manual attentively prior to use.

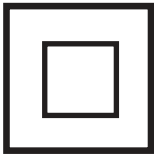

Double-insulated.



Use eyes protective equipment



Use ears protective equipment



Subjected to recycling



4. MACHINE DESCRIPTION AND PACKAGE CONTENT

Machine Description (see Fig. 1.2)

- 1 - Switch
- 2 - Handle
- 3 - Guiding handle
- 4 - Bevel adjustment knob
- 5 - Parallel guide adjustment knob
- 6 - Parallel guide
- 7 - Circular-saw blade guide
- 8 - Circular-saw base
- 9 - Blade stud
- 10 - Cutting depth adjustment knob
- 11 - Safety switch
- 12 - Carbon brush cover
- 13 - Allen wrench
- 16 - Bevel angle measuring rod

Package Content

Remove the machine carefully from the packaging and check the completeness of the following parts:

- ✿ Circular saw
- ✿ Parallel guide
- ✿ 1 circular-saw blade
- ✿ Warranty certificate
- ✿ Operating instructions
- ✿ Allen wrench

If some parts are missing or are damaged, please contact the vendor where you purchased the machine.

5. SAFETY INSTRUCTIONS

Before use, please read these safety instructions and keep them in a safe place.

- ⚠ ATTENTION!** This symbol indicates risk of injury or damage to the equipment.
- ⚠ ATTENTION!** Upon failure to follow the instructions specified in this manual, there is a risk of injury.
- ⚠ ATTENTION!** Electric circular saw conforms to applicable technical regulations and standards.
- ⚠ ATTENTION!** Before putting the circular saw aside, make sure all moving parts have stopped.

Special Safety Instructions for Operation of the Circular Saw

- ⚠ ATTENTION!** Risk of Injury! Turn off the saw and unplug the plug from the outlet before attempting to install or remove the circular-saw blade. This way you prevent the circular saw from being accidentally started.
- ✿ The root of the circular-saw blade should always be in tight contact with the cut material.
- ✿ Keep your hands away from the circular-saw blade.
- ✿ Never touch the bottom of the material during cutting.
- ✿ Make sure the circular-saw blade is sharp, undamaged and correctly adjusted. Otherwise, the cutting edge could break and cause damage to the circular saw or operator's injury.
- ✿ Do not touch the circular-saw blade immediately after cutting. It could be hot.
- ✿ Remove the adjustment key from the saw before starting the work.
- ✿ Some machined materials may contain preservative substances which could be toxic. Avoid inhaling saw-dust while machining such materials.
- ✿ When cutting thin materials, make sure that the cut-off parts do not get into the retractable guard of the saw.
- ⚠ ATTENTION!** Wear dust mask and protective goggles while performing dusty work. Wear protective goggles conforming to DIN 58214 standard. If the circular saw is used without eye protection, foreign particles could get lodged in your eyes (such as cuttings or matchwood). This could permanently damage your eyesight. Using protective goggles that do not conform to DIN standard could result in serious injury for the reasons of possible shattering of the protective glass.
- ⚠ ATTENTION!** Choose appropriate circular-saw blade for the work you intend to do. Use this circular saw only for cutting wood, wooden materials and soft metals such as aluminium. Other materials could tear, rip or spring up, get hitched on the circular-saw blade or cause other danger.

- ⚠ **ATTENTION!** Do not use grinding discs
 - The arrow on the circular-saw blade indicating the running direction must indicate the same direction as the arrow on the circular-saw guard. The teeth of the circular-saw blade must match the running direction of the saw (downwards and forward).
 - Keep the circular-saw blade and the clamping surface of the flange clean. The flange of the circular-saw blade must always fit inwards into the rotating dropping guard (towards the circular-saw blade).
 - Make sure that all clamping devices and locking devices have been tightened and that no parts shows excessive idle travel.
- ⚠ **ATTENTION!** Never cut objects while holding them in your hand.
- ⚠ **ATTENTION!** Make sure that the already cut-off parts cannot get into contact with the circular-saw blade as they may be caught by the circular-saw blade and sprung up.
- ⚠ **ATTENTION!** Never cut more than one piece of material at the same time.
- ⚠ **ATTENTION!** Be especially careful when cutting large, very small or irregular pieces.
- ⚠ **ATTENTION!** No nails or other foreign objects may be present in the part of the machined piece to be cut.
- ⚠ **ATTENTION!** No persons are allowed to stay near or behind the circular saw where saw dust and cuttings are thrown away.
- ⚠ **ATTENTION!** Do not use the circular saw for cutting fire wood.
- ⚠ **ATTENTION!** Do not attempt to stop the circular-saw blade from rotating by exerting pressure to its lateral face.
- ⚠ **ATTENTION!** Do not use circular-saw blades which do not conform, in terms of dimensions and shape, to the requirements of this tool. Before cutting, fix the work-piece firmly e.g. using clamps (they are not part of the supply).
- ⚠ **ATTENTION!** Keep your hands away from the cutting area and from the circular-saw blade. Use your other hand to hold the auxiliary handle or the engine cover. If you hold the circular saw with your both hands, they cannot be cut by the circular-saw blade.
- ⚠ **ATTENTION!** Adjust the cutting depth to at least the thickness of the processed material.
- ⚠ **ATTENTION!** If you carry out work during which the tool could get into contact with hidden electric wiring or its own cord, hold the power tool by insulated gripping surfaces intended for holding.
- ⚠ **ATTENTION!** Maintain a firm grip with both hands on the saw and position your arms to resist kickback forces. Position your body to either side of the circular-saw blade but not in line with the circular-saw blade.

- ⚠ **ATTENTION!** During longitudinal cutting, always use the longitudinal guide scale or straight guide rail.
- ⚠ **ATTENTION!** Never use damaged or incorrect washers or clamping bolts.
- ⚠ **ATTENTION!** If the circular-saw blade is pinched or when interrupting a cut for other reason, release the trigger and hold the saw motionless in the material until the blade comes to a complete stop.
- ⚠ **ATTENTION!** Never attempt to remove the saw from the work or pull the saw backward while the blade is in motion. A kickback may occur.
- ⚠ **ATTENTION!** When restarting the saw in a work-piece, centre the saw blade in the kerf and check that saw teeth are not engaged into the material.
- ⚠ **ATTENTION!** Support large panels to minimize the risk of blade pinching or kickback.
- ⚠ **ATTENTION!** Do not use dull or otherwise damaged blades.
- ⚠ **ATTENTION!** Blade depth and bevel adjusting locking levers must be tight and secure before making a cut.
- ⚠ **ATTENTION!** Use extra caution especially when making a “plunge cut”, e.g. cut into existing walls or blind areas.
- ⚠ **ATTENTION!** Never operate the saw without the blade guard attached.

Lower guard

- ⚠ **ATTENTION!** Check lower guard for proper closing before each use.
- ⚠ **ATTENTION!** Do not operate the saw if the lower guard does not move freely and close instantly! Never clamp or tie the lower guard into the open position.
- ⚠ **ATTENTION!** Check the operation of the lower guard spring. If the guard and the spring are not operating properly, they must be repaired before use.
- ⚠ **ATTENTION!** Lower guard should be retracted manually only for special cuts such as “plunge cuts” or “compound cuts”. Raise the lower guard by the lower guard lift lever and as soon as the blade enters the material, the lower guard must be released.
- ⚠ **ATTENTION!** Always observe that the lower guard is covering the blade before placing saw down on the bench or floor.

Riving knife

- ⚠ **ATTENTION!** Use appropriate riving knife for the circular-saw blade used.
- ⚠ **ATTENTION!** Adjust the riving knife as indicated in the instructions for use.

- ⚠ **ATTENTION!** Except for plunge cuts, always use the riving knife.
- ⚠ **ATTENTION!** In order for the riving knife to work, it must fit into the cut-out in the processed piece.
- ⚠ **ATTENTION!** Do not operate the saw if the riving knife is bent.
- ⚠ **ATTENTION!** Make sure that the riving knife is so adjusted that the distance between the riving knife and the blade rim is not greater than 5 mm and the blade rim does not reach out behind the lower edge of the riving knife by more than 5 mm.
- ⚠ **ATTENTION!** When replacing the circular-saw blade, make sure that the cut width is not smaller than the depth of the riving knife.

Avoid the kickback of the saw.

- ⚠ **ATTENTION!** Kickback occurs when a force is exerted against the saw blade causing a quick and unexpected lift up of the wood. Kickback is very dangerous but can be minimised if you identify its causes and avoid them.
- ✿ The root of the circular-saw blade should always be in tight contact with the cut material
- ✿ Always hold the saw with your both hands. Support the cut parts by large panels.
- ✿ Be careful when cutting long parts which can be bent, twisted or pinch the circular-saw blade.
- ✿ Never cut in the centre of the supported piece of wood. The wood could bend over and pinch the circular-saw blade.
- ✿ Never cut overhead.
- ✿ Do not exert pressure upon the saw. Let the circular-saw blade work at its own rate.
- ✿ Secure the flange using clamps or cramp to avoid vibrations and irregular cuts.
- ✿ Do not let the blade leave the cutting line as it could cause the saw jump out of the kerf.
- ✿ Before cutting, check the wood and remove all bolts, clamps and nails.
- ✿ Replace the circular-saw blade if it is dull.
- ✿ Only use circular-saw blades according to EN 847-1 and never use circular-saw blades made of high speed steel - HSS.
- ⚠ **ATTENTION!** Wear hearing protection to reduce the risk of impaired hearing! Use protection against dangerous dust inhaling.
- ⚠ **ATTENTION!** Wear gloves when working with circular-saw blades and roughly machined materials - circular-saw blades should be carried in holders, if possible.
- ⚠ **ATTENTION!** Use means of protection against noise, dust and vibrations !!!
- ⚠ **ATTENTION!** Keep these safety instructions.

6. USE AND OPERATION

The circular saw is supplied with a circular-saw blade intended for making straight cuts in wooden materials. After replacement of the circular-saw blade, you can also cut plastics, thermoplastics, hard plastics, laminate, polyurethane foam boards, mineral wool insulation boards, cement bricks, cellular concrete and products made of non-ferrous metals. The saw is intended for household or hobby use only. Any other use is strictly prohibited.

7. ADJUSTMENT AND OPERATION

Portable circular saw operation

- ✿ Turn on the saw and allow the blade to reach full speed before starting the cut, i.e. before the blade touches the material.
- ✿ Do not exert too much force upon the saw, give it enough time for cutting.
- ✿ Hold the saw with your both hands using both handles. This is the best way to control the saw.
- ✿ The part being cut automatically applies pressure the retractable guard of the machine.
- ✿ During cutting, push the circular saw evenly and smoothly forward.
- ✿ The part to be cut off must be on the right-hand side of the saw so that the wide part of the base plate is fully supported.

Attaching the parallel guide (see Fig. 3)

- ✿ The parallel guide /6/ allows cuts parallel to the edge the distance of which does not exceed 10 cm.
- ✿ Loosen the adjustment knob /5/- clockwise direction
- ✿ Insert the parallel guide /6/ into the saw base /8/ .
- ✿ Adjust the parallel guide at the desired distance and tighten the adjustment knob /5/ - anticlockwise
- ✿ Unscrew the adjusting screw.
- ✿ Adjust the parallel stop according to the scale taking also into account the circular-saw blade width.

⚠ ATTENTION! Before making a clean cut, perform a testing cut using a material chunk.

Blade replacement (see Fig. 5)

⚠ ATTENTION! Before the blade replacement, always disconnect the saw from the mains.

⚠ ATTENTION! Use only sharp and undamaged blades. Cracked or bent blades must be immediately replaced.

⚠ ATTENTION! Make sure that the spindle diameter matches the blade hole.

- ✿ Secure the clamping nut using the flange wrench 14 and loosen it using the Allen wrench 13 anticlockwise.
- ✿ Retract the blade guard and remove the blade stud, washer and flange.
- ✿ Remove the old saw blade and insert a new blade. Make sure the direction of the teeth matches the rotation direction indicated by an arrow on the fixed blade guard.
- ✿ Press down the shaft lock lever. Close the blade guard.
- ✿ Insert the flange, washer and blade stud and tighten firmly.

Cut depth adjustment (see Fig. 6)

- ✿ Loosen the adjusting screw /10/ - anticlockwise.
- ✿ Move the base /8/ downwards.
- ✿ Using the scale, adjust the desired cut depth. The upper cutting line must protrude from the material by approx. 2 mm and tighten the adjusting screw /4/
- ✿ Maximum cut depth is attained by adjusting the bevel at 45°.

Bevel adjustment (see Fig. 7)

- ✿ Unscrew the adjusting screw /4/.
- ✿ Adjust the desired bevel according to the scale /16/ in the range 0-45°.
- ✿ Tighten the adjusting screw /4/.

Riving knife adjustment

- ✿ Open the lower blade guard and hold it firmly.
- ✿ Unscrew the screws.
- ✿ Adjust the riving knife and tighten the screws.

Before switching the tool on

Before switching the machine on, make sure the circular-saw blade is correctly mounted, that all moving parts move freely and that all adjusting screws are firmly tightened.

Starting and stopping the tool (see Fig. 8)

The tool is equipped with double-acting safety switch: the saw can only be started if you hold the handle firmly and press both safety switches. After releasing the handle, the saw is automatically switched off to prevent accidental machine operation.

Replacement of carbon brushes

⚠ ATTENTION! In case of carbon brush seasoning, immediately switch off the saw and contact the nearest service centre of FAST ČR, a.s. or your nearest vendor.

- ✿ Use only correct types of carbon brushes.
- ✿ After attaching new carbon brushes, let the saw run on idle for approx. 5 minutes.

8. CLEANING AND MAINTENANCE

- ✿ Keep the engine vent holes clean and dust-free.
- ✿ If the circular-saw blade is damaged, replace it immediately by a new blade of the same type.

⚠ ATTENTION! Before cleaning and maintenance, always unplug the supply cable of the tool from the socket.

- ✿ The tool requires no special maintenance, just wipe the cover of the tool with a wet cloth on a regular basis.
- ✿ Clean the vent holes on a regular basis.
- ✿ Never clean any part of the tool using a hard, sharp or rough object.

9. CLEANING AND MAINTENANCE TIPS

- ✿ Store the tool, accessories and instructions for use in the original packaging to ensure you always have all necessary parts and information.
- ✿ If the tool is not used for a long time, do not store it in places with high temperatures.
- ✿ If practicable, store the tool in a place with constant temperature and humidity.
- ✿ Avoid contact of the tool with humidity and water. Follow the instructions specified in this operating manual

10. TECHNICAL DATA

ELECTRICAL CIRCULAR SAW:	
Power supply	230V/50Hz
Power input	800W
Speed	4000rpm
Protection class	II
Blade Diameter	140 mm
Cutting capacity	45mm at 90 degree, 28mm at 45 degree
Power supply cable length	1.8m
Declared noise level	98dB(A)
Vibration	$a_h=3.2 \text{ ms}^{-2}$, $k=1.5 \text{ ms}^{-2}$

Instructions Manual - language version only.

Amendments to text and technical parameters are reserved.

Changes in the text, design and technical specifications may change without prior notice and we reserve the right to make these changes. keep it from turning as the drill bit rotates.

Troubleshooting

Suspected malfunctions are often due to causes the user can fix themselves. Therefore check the product using this section .In most cases the problem can be solved quickly .

WARNING!

Only perform the steps described within these instructions! All further inspection ,maintenance and repair work must be performed by an authorized service centre or a similarly qualified specialist if you cannot solve the problem yourself !

Problem	Possible Cause	Solution
1. Product does not start	1.1 Not connected to power supply 1.2 Power cord or plug is defective 1.3 Other electrical defect to the product	1.1 Connect to power supply 1.2 Check by a specialist electrician 1.3 Check by a specialist electrician
2. Product does not reach full power	2.1 Extension cord is not suitable for operation with this product . 2.2 Power source (e.g. generator) has too low voltage 2.3 Air vents are blocked	2.1 Use a proper extension cord 2.2 Connect to another power source 2.3 Clean the air vents
3. Unsatisfactory result	3.1 Disk bit is dull/damaged 3.2 Disk bit is not suitable for work piece material	3.1 Replace with new one 3.2 Use proper drill bit
4. Excessive vibration or noise	4.1 Disk bit is dull/damaged 4.2 Bolts /nuts are loose	4.1 Replace with a new one 4.2 Tighten bolts/nuts

11. LIQUIDATION

INSTRUCTIONS AND INFORMATION ON DISPOSAL OF USED PACKAGING.

Put any used package material to the place determined by the municipality for waste disposal.

DISPOSAL OF USED ELECTRIC AND ELECTRONIC EQUIPMENT



This symbol on products or accompanying documents means that used electric or electronic products must not be put to ordinary municipal waste. Hand over such products to determined collection points for proper disposal, restoration and recycling. Alternatively, in some countries of the European Union or other European countries you can return your products to your local dealer when you buy an equivalent new product. By dutiful disposal of this product you can preserve precious natural resources and you help prevent any potential adverse effects on the environment and human health which could be the results of wrong waste disposal. Ask your local authority or the nearest collection point for additional details. In case of improper disposal of this waste kind penalties can be imposed in accordance with national regulations.

For companies in the European Union countries

Should you want to dispose of electric and electronic devices, ask your dealer or vendor for necessary information. Disposal in other countries outside the European Union. Should you want to dispose of this product, ask your local authorities or your dealer for necessary information about disposal method.



This product fulfils all basic requirements of the EU directives that apply to it.

Text, design and technical specifications can change without prior notice and we reserve the right for their change.

EU DECLARATION OF CONFORMITY

Product / brand: Electrical Circular Saw / **FIELDMANN**

Type / model: **FDK 200802-E** as factory model M1Y-GW2-140
AC 230V; 50Hz; 800W; speed 4000/m⁻¹, diameter 140mm, Class II
L_{PA} = 90 dB(A), L_{WA} = 101 dB(A)

Manufacturer: FAST ČR, a.s.
Černokostecká 2111, 100 00 Praha 10, Czech Republic
VAT no: CZ26726548

The product is inline with directives and regulations listed below:

Directive MD 2006/42/EC
Directive EMC 2014/30/EU
Directive NEOE 2000/14/EC
Directive RoHS 2011/65/EU

and norms:

EN 62841-1:2015
EN 62841-2-5:2014
EN 55014-1:2017
EN 55014-2:2015
EN IEC 61000-3-2:2019
EN 61000-3-3:2013+A1



Place of issuance: Prague

Name: Ing. Zdeněk Pech
Chairman of the Board

Date of issuance: 12. 9. 2022

Signature:

FAST[®] FAST ČR, a.s. 
Černokostecká 1621, 251 01 Říčany
IČO: 26726548 tel.: +420/ 323 204 111
DIČ: CZ26726548 fax: +420/ 323 204 110