

UTOPIA

Technical specifications /
Spécifications techniques

6WM: 2
8WM: 4
TBM: 6
3.5WM: 8
SUB10WM: 10
165W-XP: 12

6WM

Woofer 6^{1/2}"

MECHANICAL DRAWING

Dimensions in mm

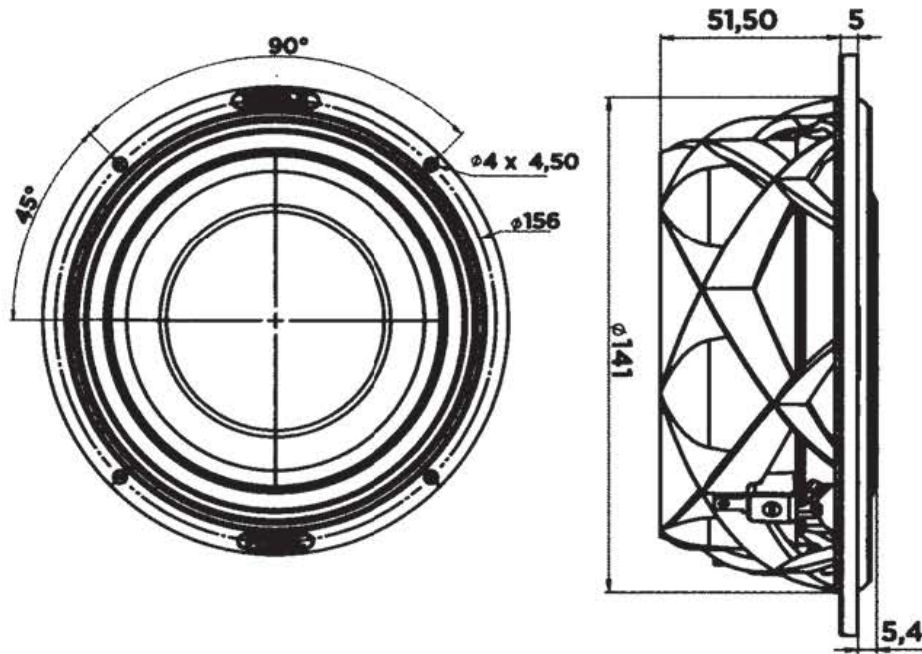

FREQUENCY RESPONSE

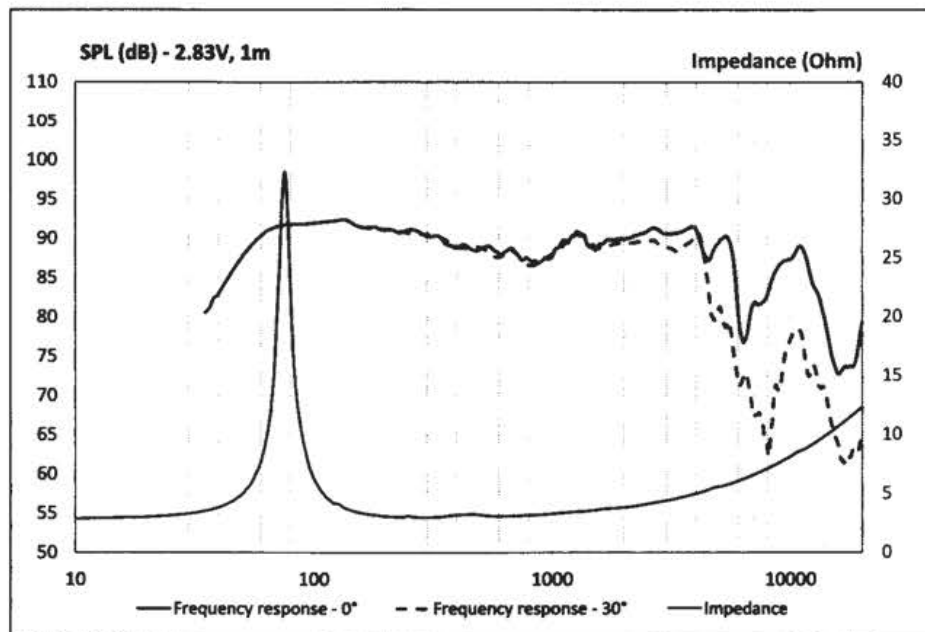

6WM

Technical specifications

3

SPECIFICATIONS

Nominal power	100W	
Maximum power	200W	
Sensitivity (2.83V/1m)	91.5dB	
Nom. Impedance	4Ω	
Cone	W	
Surround	Butyl	
DC resistance	2.7Ω	
VC diameter	80mm	3 ¹ / ₈ "
Former	Glass Fiber	
Layers	1	
Wire	CCAW	
Magnet D x H	75x4mm	2 ¹⁵ / ₁₆ " x 0 ³ / ₁₆ "
Net weight	1,050g	2.3lbs

PARAMETERS

Rdc	2.7Ω
Fs	70Hz
Mms	14.5g
Cms	0.36mm/N
Vas	8.5l
Qts	0.79
Qes	0.86
Qms	10.5
Bxl	4.4N/A
Sd	132.7cm ²
SPL	89.3dB
Xmax	5.5mm





You have just purchased a Focal product. We would like to thank you and welcome you to our world, the world of High-Fidelity... Focal has been designing, developing and manufacturing speaker drivers and loudspeakers for more than 35 years, and more recently headphones. Innovation, Tradition, Performance and Pleasure are our key values. Wherever you are, only one goal for us: gathering you around a common passion, the rich, faithful and pure sound. Listen Beyond.

MADE IN FRANCE

The speaker driver is what is at the core of Focal's DNA, it is what the historical root of our trade is built around: technology, mechanics and sophisticated materials. Focal's history is written every day by men and women whose unique expertise pushes back the limits of sound reproduction. We are proud to have succeeded in keeping our own manufacturing facilities, which was the only feasible way for us to continue innovating and developing our expertise and technology. This has given us unique recognition, that of being awarded a Living Heritage Company label (Entreprise du Patrimoine Vivant).

EXCELLENCE

Whether it is a loudspeaker, a studio monitor, a car audio kit or headphones, we only develop products that we are certain will become a reference in their category. All our products are designed and manufactured with the same quality standards, by the same teams of engineers and specialised operators in order to provide the best audio solutions, whatever the size or price, from entry-level products to luxury ranges. That is what makes our offer and our brand unique.

INNOVATION

Innovation means pushing back the limits of the impossible. Innovation requires a certain frame of mind, the freedom to brave the extravagant, to dare the impossible... Utopia perfectly symbolises this. Above all, it is a desire which has been part of Focal since day one, a desire driven by the passion for sound and all its delights. Today, innovation goes way beyond technology, it also involves aesthetics and usage. And to achieve innovation without constraint, there was no other way for Focal than to master each and every process, including manufacturing of course...

PLEASURE

That is the ultimate goal, our quest: to offer you audio devices which bring you closer to artists and their intentions, their intimacy, with pure, faithful sound whose harmonic richness paves the way for listening pleasure. What is more, today, music follows you everywhere... From the recording studio to the living room, from your car to the street, and we want to be the only ones taking care of reproducing your music for your greatest pleasure.

classic loudspeakers



headphones & multimedia



car audio



studio monitors



FOCAL

