

CERTAIN 2013-2014 FUSION, 2013-2015 TRANSIT CONNECT, 2014 ESCAPE, AND 2014-2015 FIESTA ST VEHICLES EQUIPPED WITH A 1.6L ECOBOOST ENGINE — COOLANT LEVEL SENSOR SYSTEM INSTALLATION

2013-2014 FUSION TECHNICAL INFORMATION

OVERVIEW

In the affected vehicles, localized overheating of the engine cylinder head may cause the cylinder head to crack, causing a pressurized oil leak that may result in a fire in the engine compartment.

Service parts and repair procedures are now available to address this safety recall. Dealers are to perform repairs following the technical information in this document that include enhancements to the engine cooling and control systems. This service must be performed on all affected vehicles at no charge to the vehicle owner.

Due to the complexity of this repair, the following considerations have been made to help the repair procedure go as smoothly as possible:

- Repair procedures have been divided alphabetically into multiple separate procedures.
- Parts have been packaged into kits.
- Each procedure includes:
 - Overview
 - List and photo of the parts required
 - List of unique tools needed
 - Service tips to help complete the repair

NOTE: Please read this procedure in its entirety, prior to performing repairs. Additionally, instructional videos have been developed to assist with the repair. Please refer to Attachment VII: Instructional Video Links to view the videos.



Recommended Tools:

General Tools	General Equipment
1/4" Drive Ratchet (Power and Hand Tool)	Floor Jack
1/4" Drive 7, 8, and 10 mm Shallow Sockets	Wood Block
1/4" Drive 10 mm, 12 mm Deep Sockets	Coolant Pressure Tester
1/4" Drive 8 mm Swivel Socket	Drain Pan
1/4" Drive E8 Inverted Torx Socket	Battery Charger
1/4" Drive T-30 Torx Bit Sockets	Extension Cord
1/4" Drive 4 in (101 mm) and 16 in (406 mm) Extensions	Tape/Electrical Tape
3/8" Drive Ratchet (Power and Hand Tool)	
3/8" Drive 11 mm, 13 mm, and 15 mm Deep Impact Socket	
3/8" Drive 15 mm Shallow Impact Socket	Special Tools
3/8" Drive 15 mm Swivel Impact Socket	Hydrometer/Refractometer
3/8" Drive 1 in (25 mm) Extension	Vacuum Tester/Re-filler
1/2" Drive Ratchet Power Tool and Hand Tool	IDS and VCM II
1/4" and 1/2" Drive Impact Swivel	
1/2" Drive 18 mm Deep Impact Socket	
1/2" Drive 15mm Shallow Impact Socket	
1/2" Drive 6" (152 mm) and 10" (254 mm) Impact Extensions	
1/2" Drive Torque Wrench	
1/4" And 3/8" Drive Torque Wrench	
15 mm Ratchet Wrench	
17 mm Wrench 15 in (381 mm)	
Channel Lock Pliers	
Trim Tool 7 in (177 mm) and 12 in (304 mm)	
Inspection Mirror	
Screwdriver 8 in (203 mm)	
Paint Stick/Pen	
Scissors	
Cable Operated Hose Pliers	
4 in (101 mm) Pick Tool	
Pocket Screwdriver	
Side Cutters	
Needle Nose Pliers 8 in (203 mm) and 11 in (279 mm)	
Hose Hook Tool	



SERVICE PROCEDURE

Procedure A - Initial Disassembly and Preparation for Inspection

OVERVIEW: This procedure details the components to be removed to enable initial vehicle inspection.

PARTS / SUPPLIES REQUIRED: None

UNIQUE TOOL REQUIREMENTS: None

SERVICE TIPS: Please note the following:

- The Inspection / Check Sheet (Attachment IV) must be printed and started during "Procedure A".
- The air cleaner, mass air flow sensor and air intake tube are removed as an assembly.
- Cover the turbocharger inlet opening to prevent dropping any parts or debris into the turbocharger while the turbocharger inlet pipe is off.

1. Print a copy of the Inspection / Check Sheet (Attachment IV), to record vehicle information and inspection/repair information for the vehicle. The Inspection / Check Sheet is to be attached/filed with the recall repair order following completion, it does not need to be provided to Ford at this time.

2. Fill out top of Inspection / Check Sheet including:

- VIN
- Technician ID
- Repair Order Number
- Repair Date
- Vehicle Mileage
- Vehicle Build Date
- Open Recalls

3. Using OASIS, document vehicle build date on the Inspection / Check Sheet.

4. With the vehicle in NEUTRAL, position it on a hoist. Please follow the Workshop Manual (WSM) procedures in Section 100-02.

5. Using IDS/scan tool, retrieve and record DTCs on the Inspection / Check Sheet.

- Any DTCs recorded will be used later in this procedure.

6. Remove the engine appearance cover.



All Vehicles

NOTICE: When working with liquid or vapor tube connectors, make sure to use compressed air to remove any foreign material from the connector retaining clip area before separating from the tube or damage to the tube or connector retaining clip can occur. Apply clean engine oil to the end of the tube before inserting the tube into the connector.

NOTICE: Whenever turbocharger air intake system components are removed, always cover open ports to protect from debris. It is important that no foreign material enter the system. The turbocharger compressor vanes are susceptible to damage from even small particles. All components should be inspected and cleaned, if necessary, prior to installation or reassembly.

7. Detach the EVAP line from the clip on the air intake tube center section. See Figure A1.
8. Loosen the clamp and disconnect the air intake tube from the turbocharger inlet pipe. See Figure A1.

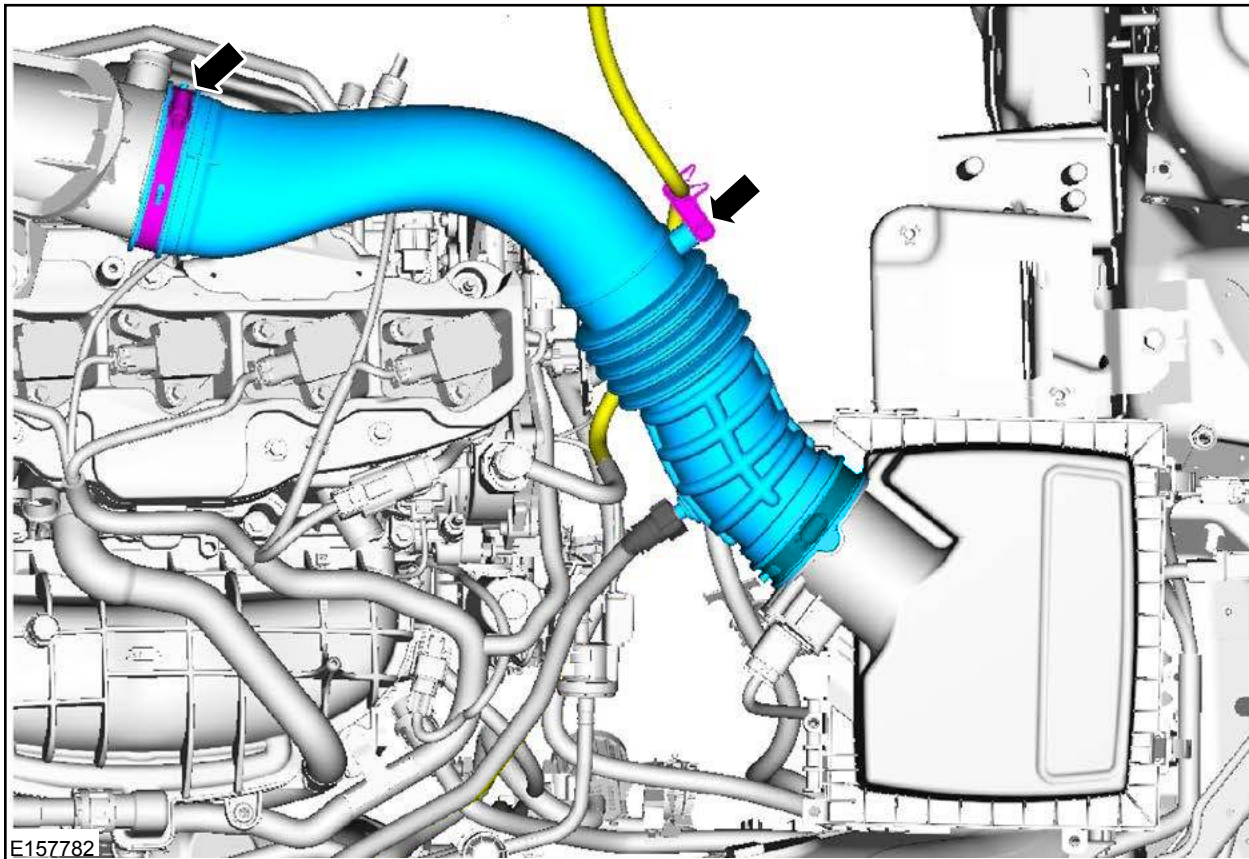

FIGURE A1



NOTE: The air cleaner assembly is removed from the vehicle with the mass air flow sensor and air intake tube attached.

9. Remove the air cleaner assembly. See Figure A2.

- a. Remove the two bolts
- b. Disconnect the mass air flow sensor electrical connector and wire harness retainer from the air cleaner assembly.
- c. Disconnect the EVAP hose from the air cleaner outlet tube.
- d. Lift upward to disengage the retaining grommets and remove the air cleaner assembly.

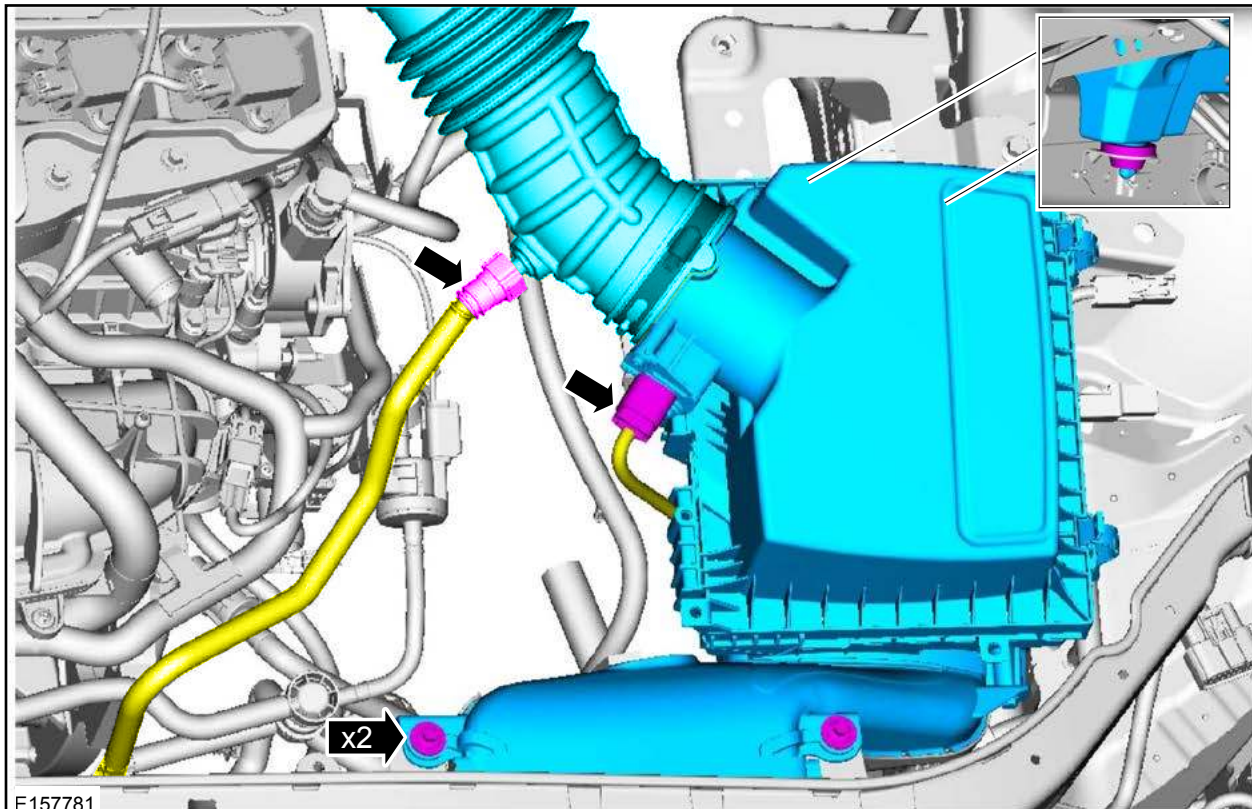

FIGURE A2



NOTICE: Whenever turbocharger air intake system components are removed, always cover open ports to protect from debris. It is important that no foreign material enter the system. The turbocharger compressor vanes are susceptible to damage from even small particles. All components should be inspected and cleaned, if necessary, prior to installation or reassembly.

10. Remove the turbocharger air inlet pipe. See Figure A3.

1. Disconnect the crankcase ventilation tube quick release coupling.
2. Remove the turbocharger air inlet pipe retaining nut, the turbocharger air inlet pipe ball stud, and the turbocharger air inlet pipe clamp.
3. Loosen the turbocharger air inlet pipe clamp and remove the turbocharger air inlet pipe.

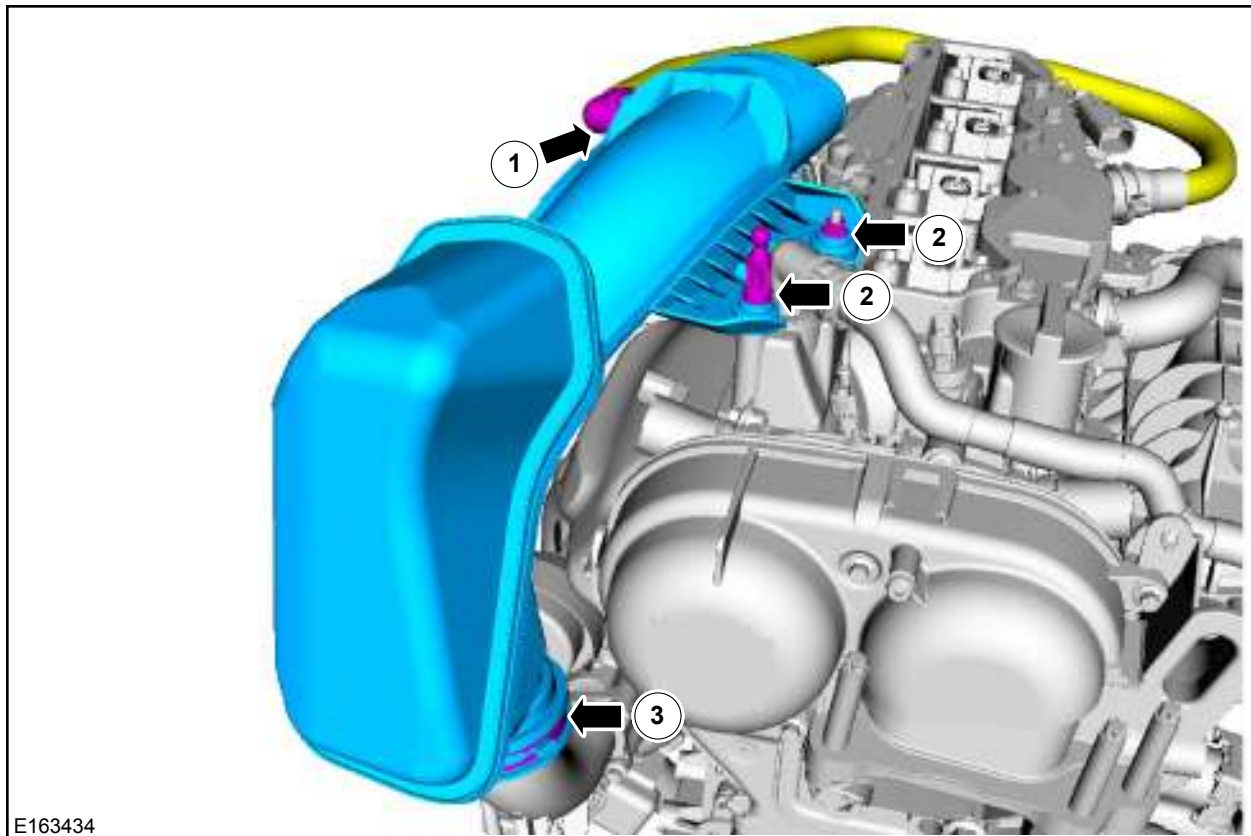

E163434

FIGURE A3



11. Remove the retainers and the front underbody air deflectors. See Figures A4 and A5.

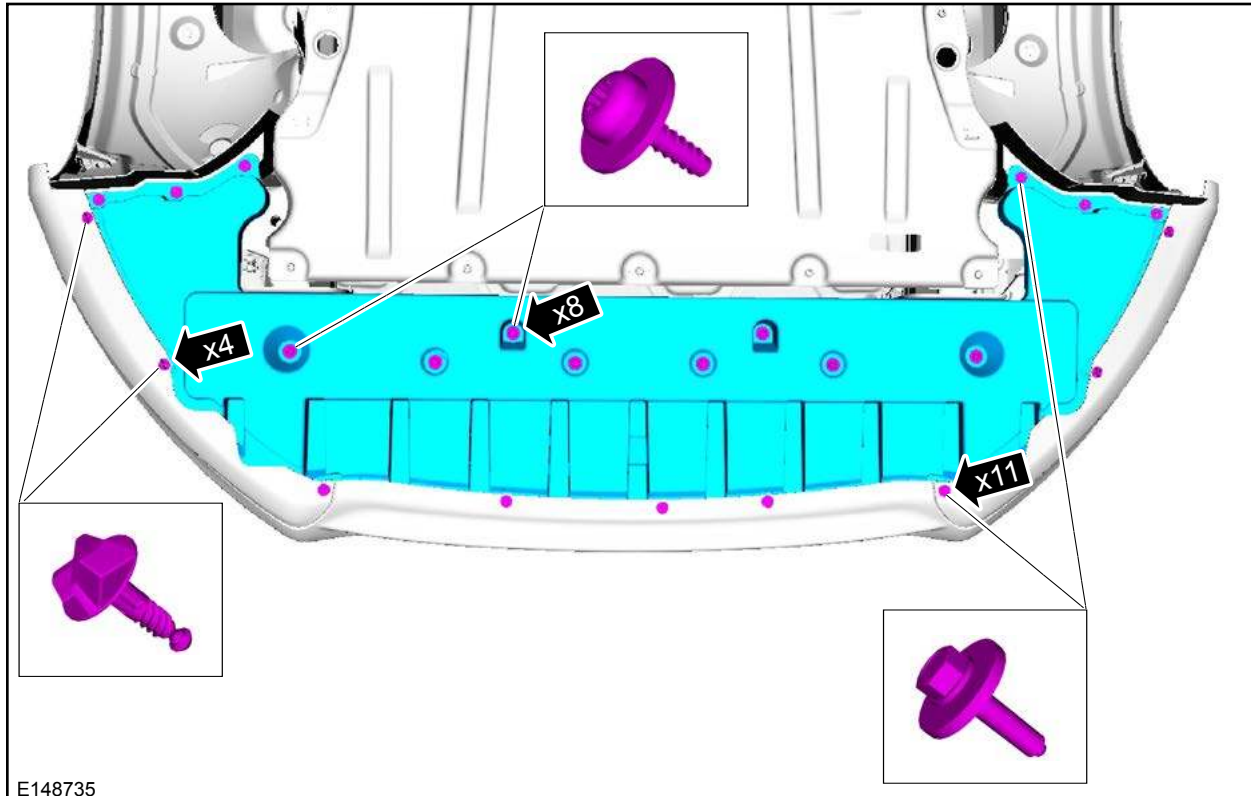

E148735

FIGURE A4

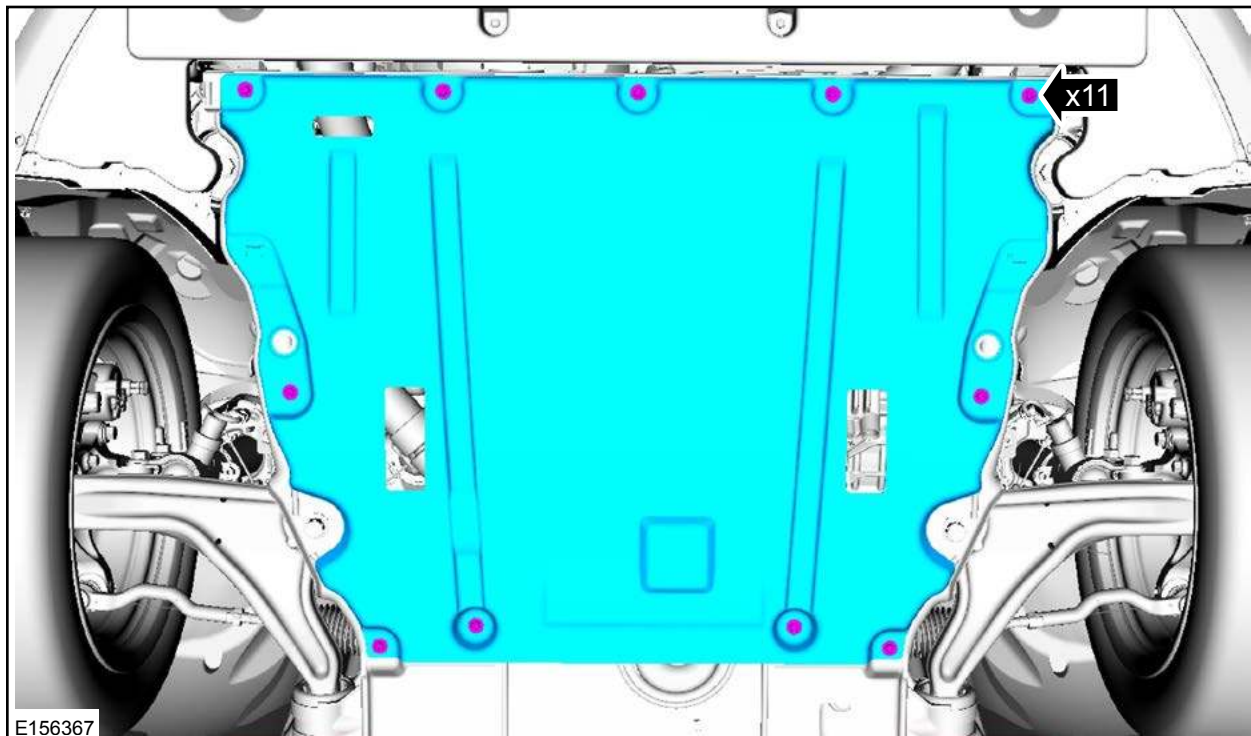

E156367

FIGURE A5



12. Detach the three wire harness retainers, disconnect the crankshaft position sensor, turbocharger wastegate regulating valve solenoid, and turbocharger bypass valve electrical connectors.
See Figure A6.

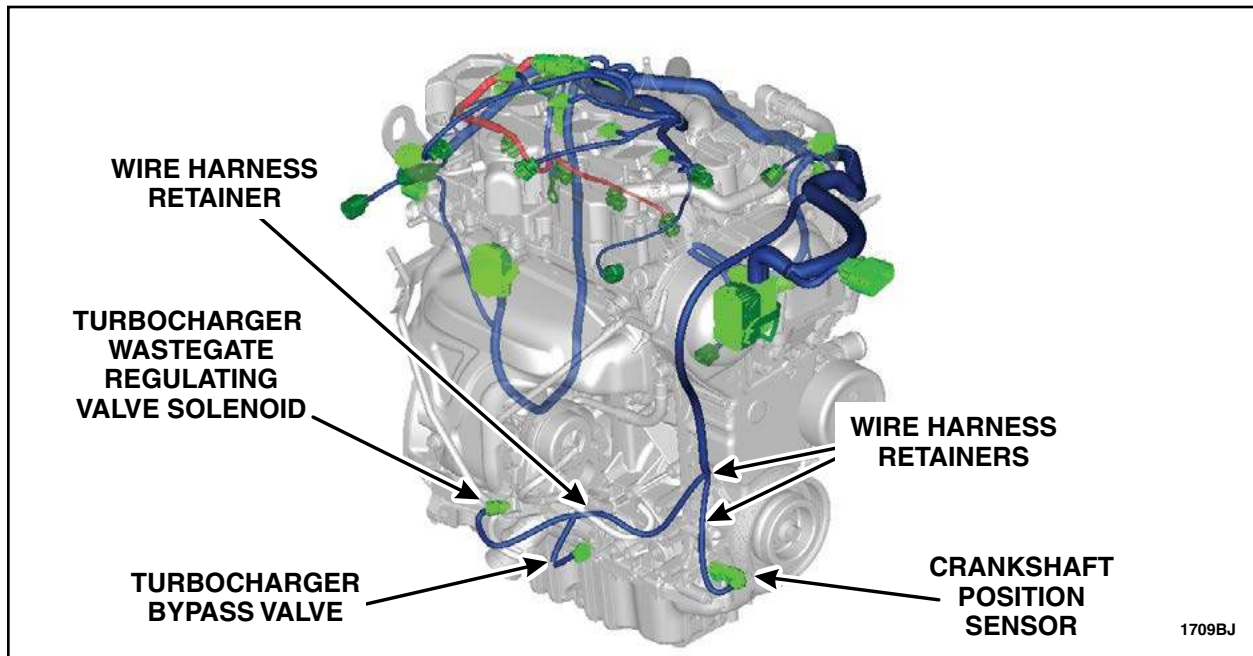

FIGURE A6

13. Remove the three nuts and position the Powertrain Control Module (PCM) aside. See Figure A7.

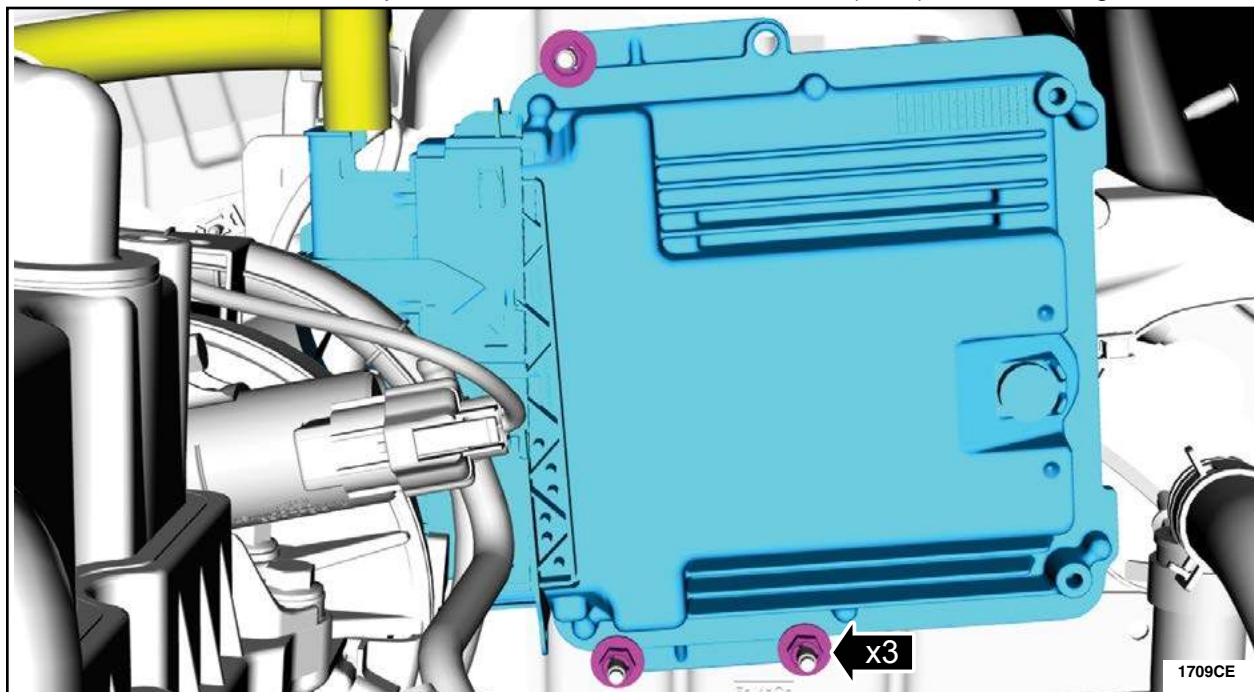

FIGURE A7



Procedure B - Inspection / Check Sheet Completion

OVERVIEW: The Inspection must be completed and documented on the Inspection / Check Sheet. The inspection will check for obvious concerns that require correction with additional focus on cooling system concerns such as:

- Internal coolant leaks
- External coolant leaks
- Any DTC(s) that could indicate a recent engine overheat event or internal engine damage that may have resulted from a previous cooling system concern.

PARTS / SUPPLIES REQUIRED: None

UNIQUE TOOL REQUIREMENTS: Rotunda Cooling System Pressure Tester (STN12270) and adapter (Snap-On TA52, AST ASSFZ-47, Redline RDL95-0750 or equivalent).

SERVICE TIPS: Use standard Workshop Manual and PC/ED Diagnostics, if necessary, to diagnose any cooling system or misfire DTC(s) retrieved and for any coolant loss concerns.

NOTE: Perform an underhood visual inspection for any obvious coolant, oil, transmission, or fuel leaks.

NOTE: If any concerns are identified repair as related damage before proceeding. If the coolant pressure test identifies concerns with the degas bottle, turbocharger return tube, upper section of the degas bottle return hose, or quick connect T-fitting at the coolant shutoff solenoid valve; note the condition. These items will be replaced as part of this recall. Refer to Dealer Bulletin Attachment I, Related Damage, for related damage claiming.

Vehicle Inspection

1. Visually inspect the coolant level in the degas bottle.

- If the coolant level **is** visible in the degas bottle, proceed to Step 2.
- If the coolant level **is not** visible in the degas bottle, add coolant as necessary, and proceed to Step 2.

NOTE: Any gross loss of coolant must be identified and repaired prior to proceeding.

2. Remove the degas bottle cap.

3. Install a coolant pressure tester with adapter onto the degas bottle. Pressurize to 138 kPa (20 psi). Once stabilized, pressure should hold at 138 kPa (20 psi) for a minimum of 2 minutes.

- If cooling system pressure does not hold for a minimum of 2 minutes, the source of pressure loss must be identified and repaired as necessary before proceeding.

4. Visually check for coolant leaks with the system under pressure.



5. Check the engine oil level to ensure it is within normal range, note if it is overfilled. Visually check for engine oil leaks at the rear surface of the cylinder head, above exhaust manifold, that may be the result of a crack in the cylinder head. See Figure B1.

- If an oil leak is detected at the rear surface of the cylinder head, replace the complete cylinder head assembly before proceeding.

NOTE: The turbocharger coolant tubes and exhaust manifold heat shield are removed for clarity.

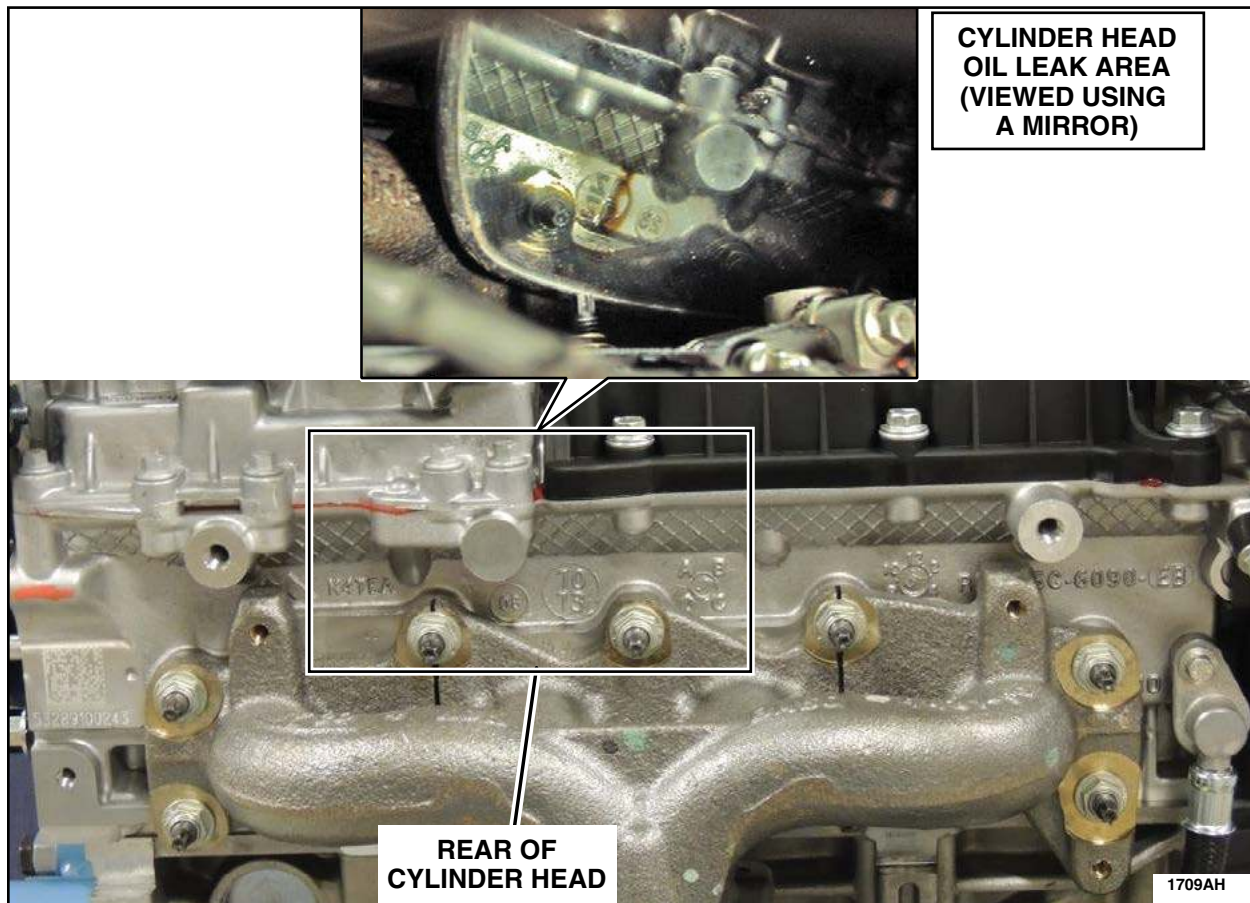

FIGURE B1



6. DTCs - Note and identify the cause of the following DTCs before proceeding:

- If additional DTCs are present, diagnose and repair as required.

NOTE: Diagnosis for any of the following DTCs may require reinstallation of the air intake components and battery. Perform diagnosis and repairs as necessary.

Cooling System DTCs	
P0217	Engine Coolant Over Temperature Condition
P0218	Transmission Fluid Over Temperature Condition
P0219	Engine Over Speed Condition
P1299	Cylinder Head Over Temperature Protection Active
Engine Misfire DTCs	
P0300	Random Misfire Detected
P030x	Cylinder X Misfire Detected
P0313	Misfire Detected With Low Fuel
P0316	Misfire Detected On Startup (First 1000 Revolutions)

7. Note any issues and/or repairs made on the Inspection / Check Sheet.



Procedure C - Powertrain Control Module Connector Back Shell Replacement - (Manual Transmission Vehicles Only)

OVERVIEW: Powertrain Control Module (PCM) connector back shell replacement is only required for vehicles equipped with a manual transmission. The new PCM connector back shell will allow for clearance between the PCM connector back shell and the new stand-pipe.

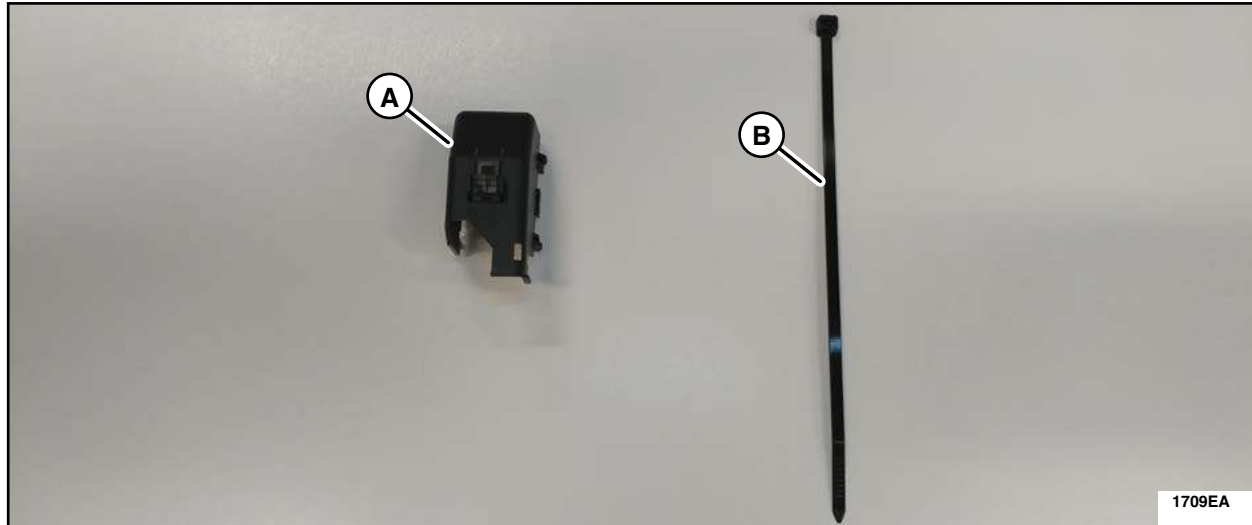

A	PCM Connector Back Shell
B	Tie-Strap

UNIQUE TOOL REQUIREMENTS: None

SERVICE TIPS: None



1. Disconnect the battery cable to ground. Please follow the procedures in WSM Section 414-01.
2. Disconnect the lower PCM electrical connector. See Figure C1.

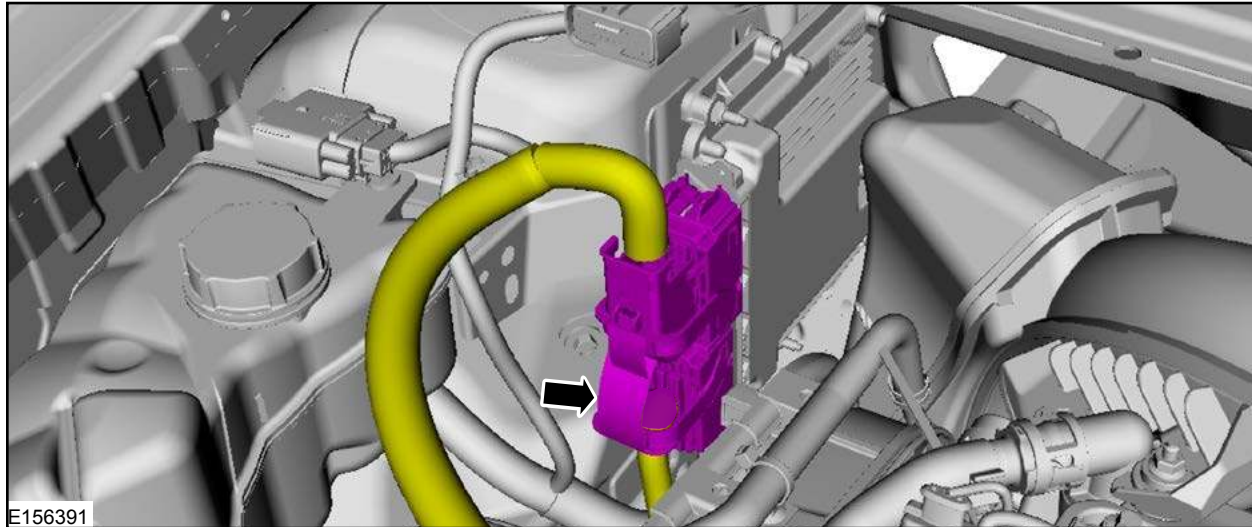

FIGURE C1

3. Replace the connector back shell with the *new* connector back shell. Secure the PCM connector wires to the back shell and the *new* tie-strap. See Figure C2.



FIGURE C2

4. Connect the lower PCM electrical connector. See Figure C1.

NOTE: Do not reconnect the battery cable to ground at this time. It will be reconnected later in the procedure.



Procedure D - Coolant Stand-pipe Wire Harness Installation

OVERVIEW: The coolant stand-pipe wire harness is partially installed in this procedure. This is necessary to complete the connections at the electronic power assist steering (EPAS) electrical connectors which are a part of the CAN Network. The CAN Network must be complete to allow module programming.

PARTS / SUPPLIES REQUIRED:

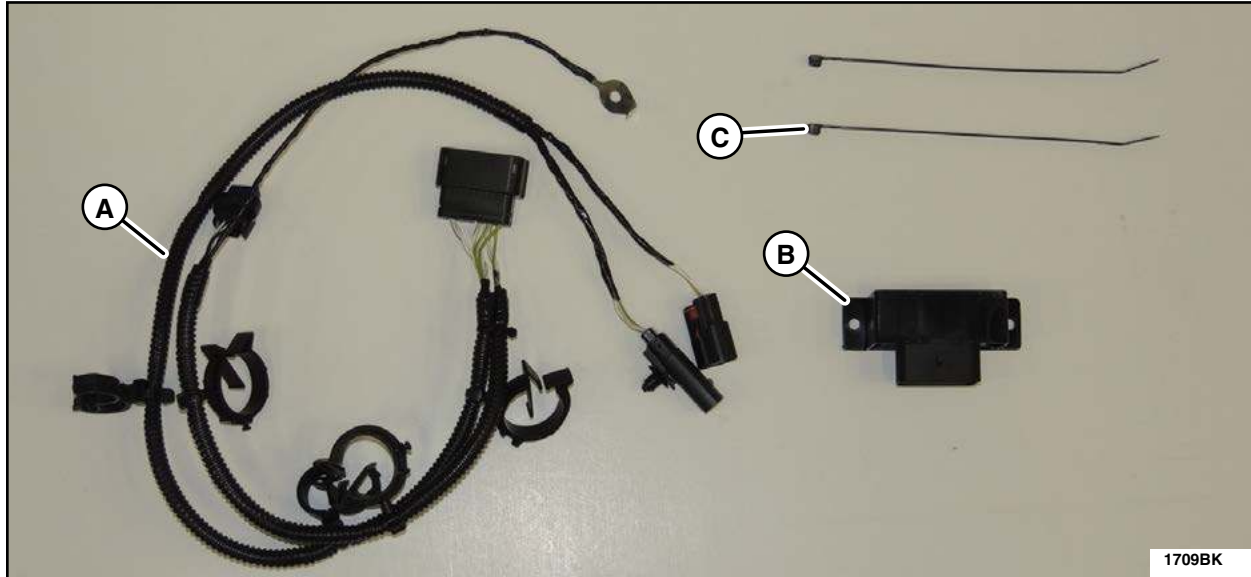

A	Coolant Stand-pipe Wire Harness
B	Junction Box
C	Tie-Straps x2

UNIQUE TOOL REQUIREMENTS: None

SERVICE TIPS: None



1. If not done previously, disconnect the battery cable to ground. Please follow the procedures in WSM Section 414-01.
2. Install the junction box and coolant stand-pipe wiring harness. See Figure D1.
 1. Position the junction box onto the engine wire harness, behind the Powertrain Control Module (PCM) and secure with the two tie-straps.
 2. Connect the electrical connector to the connector junction box.
 3. Route the coolant stand-pipe wire harness downward to the EPAS and secure to the bulkhead wire harness and A/C line as shown in Figure D1.

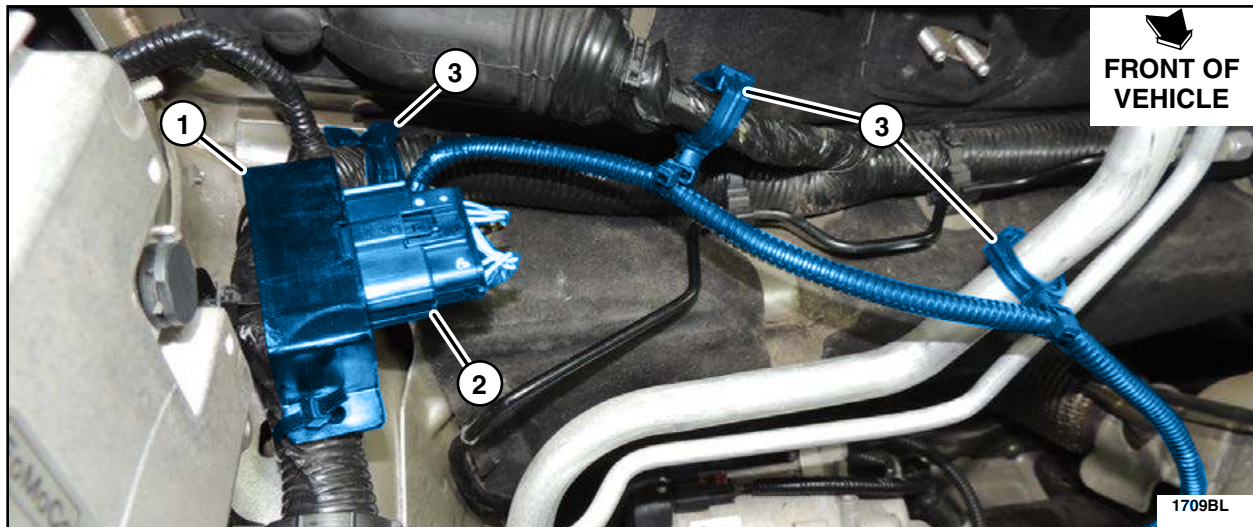

FIGURE D1

3. Disconnect the EPAS electrical connector and connect the coolant stand-pipe wiring harness to the EPAS module and the EPAS electrical connector. See Figure D2.

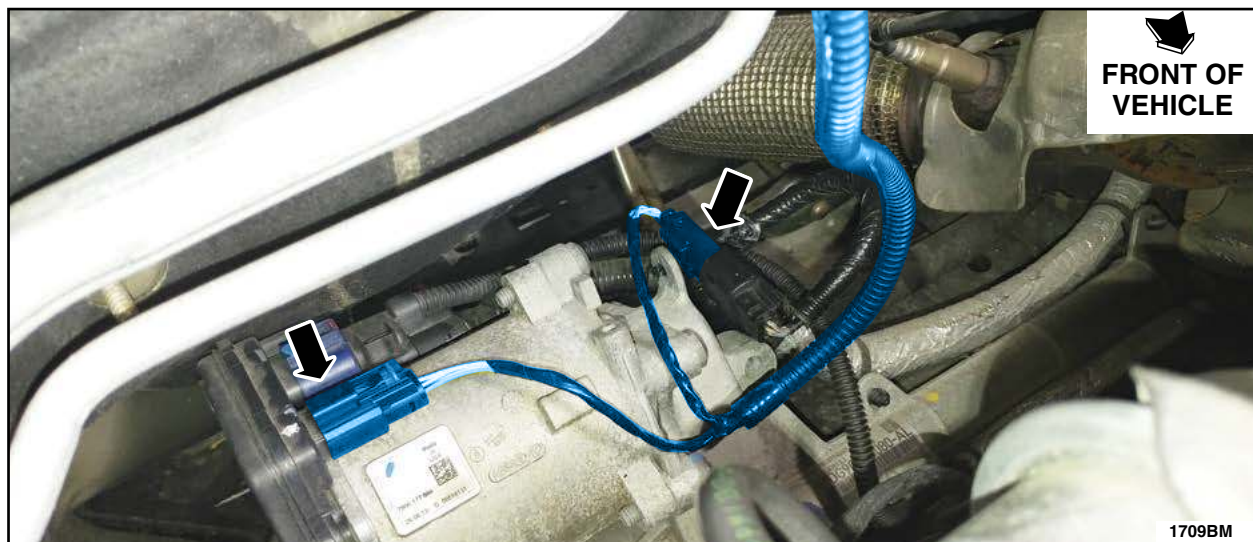

FIGURE D2



4. Route the coolant stand-pipe wire harness stand pipe electrical connector and ground eyelet wire along the lower PCM connector wire harness. Secure the stand-pipe wire harness as shown in Figure D3.

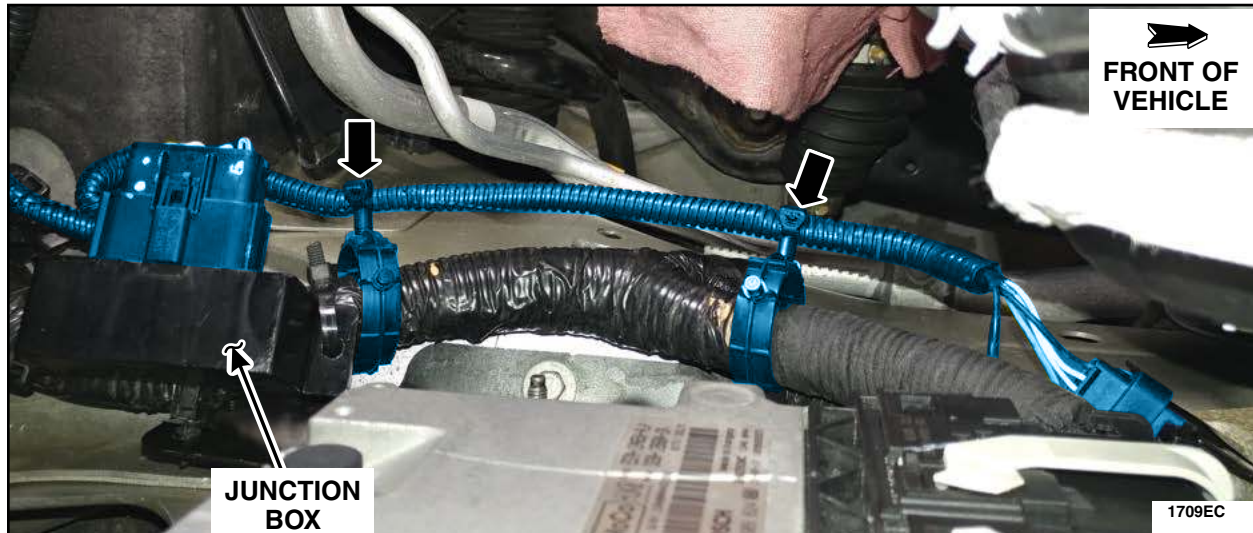

FIGURE D3

5. **NOTICE:** Ensure the surface is clean and free of any dirt and debris prior to re-installing the ground bolt.

Install the *new* coolant stand-pipe wire harness ground eyelet to the vehicle using the existing wire harness ground bolt. See Figure D4.

- Remove and reattach the upper PCM connector harness retaining clip to access the ground bolt.
- When installing tighten to 106 lb.in (12 Nm)

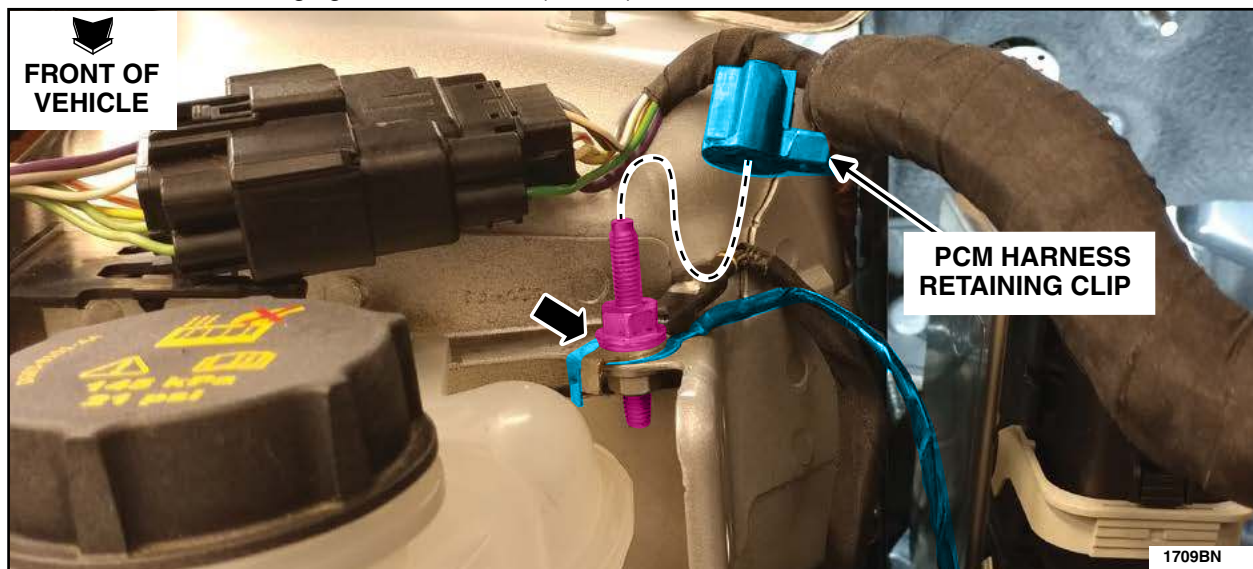

FIGURE D4



6. Position the stand-pipe wire harness electrical connector aside. It will be connected later.
7. Remove the nut and disconnect the generator battery cable and electrical connector. See Figure D5.
 - Cover the cable end using electrical tape.

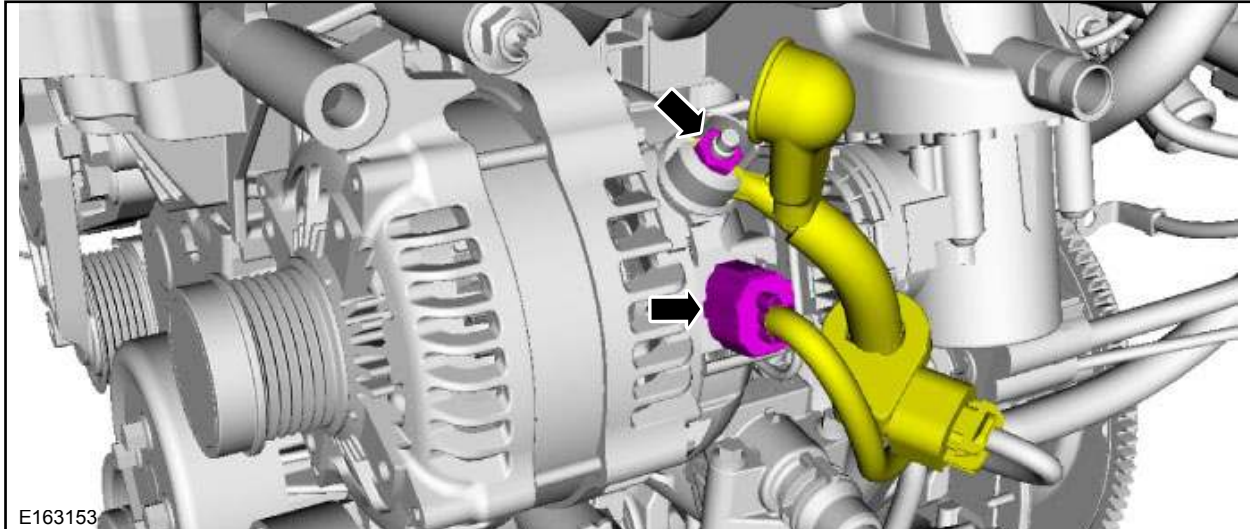

FIGURE D5

8. Connect the battery cable to ground. Please follow the procedures in WSM Section 414-01.



Procedure E - Instrument Panel Cluster (IPC) Reprogramming

OVERVIEW: The IPC software is being updated to coordinate cooling system improvements and instrument cluster messaging. IPC reprogramming can be performed while performing other repairs on the vehicle. The PCM must be reprogrammed during Procedure L after cooling system repairs and bleeding are completed.

PARTS / SUPPLIES REQUIRED: None

UNIQUE TOOL REQUIREMENTS:

- IDS with release 108.03 or higher
- Portable battery charger (10 to 20 amps)

SERVICE TIPS: Begin IPC reprogramming and continue to perform repairs during IPC reprogramming. Reprogramming times for the IPC can be significantly reduced by using a VCM II instead of a VCM.

Important Information for Module Programming

NOTE: When programming or reprogramming a module, use the following basic checks to ensure programming completes without errors.

- Make sure the 12V battery is fully charged before carrying out the programming steps and connect IDS/scan tool to a power source.
- Inspect Vehicle Communication Module (VCM) and cables for any damage. Make sure scan tool connections are not interrupted during programming.
- A hardwired connection is strongly recommended.
- Turn off all unnecessary accessories (radio, heated/cooled seats, headlamps, interior lamps, HVAC system, etc.) and close doors.
- Disconnect/depower any aftermarket accessories (remote start, alarm, power inverter, CB radio, etc.).
- Follow all scan tool on-screen instructions carefully.
- Disable IDS/scan tool sleep mode, screensaver, hibernation modes.
- Create all sessions key on engine off (KOEO). Starting the vehicle before creating a session will cause errors within the programming inhale process.
- Ensure the headlamps and accessories are turned off.



Module Reprogramming

NOTE: The IDS must be updated to software level 108.03 or later to perform the FSA. If the IDS is not updated when the FSA is performed, it may result in various DTCs and drivability concerns. It is important that all steps of this FSA are performed in the order listed. This will ensure proper operation of the vehicle once completed.

NOTE: Reprogram appropriate vehicle modules before performing diagnostics and clear all Diagnostic Trouble Codes (DTCs) after programming. For DTCs generated after reprogramming, follow normal diagnostic service procedures.

1. The IPC reprogramming can take up to 1 hour or more. Connect a portable battery charger of 10 to 20 amps to an extension cord and to the 12V battery. This will allow the vehicle to be raised and lowered as needed while completing the remaining repair procedures, and ensure uninterrupted reprogramming is achieved. Programming times can be significantly reduced by using a VCMII.

NOTE: Periodically check the status of the reprogramming progress to continue the process, as required.

2. Reprogram the IPC using IDS release 108.03 or higher.

NOTE: Follow the IDS on-screen instructions to complete the reprogramming procedure.

Recovering a module when programming has resulted in a blank module: NEVER DELETE THE ORIGINAL SESSION!

- a. Obtain the original IDS tool which will have the original IDS session, that was used when the programming error occurred during module reprogramming (MR) or programmable module installation (PMI).
- b. Disconnect the VCM from the data link connector (DLC) and the IDS.
- c. Reconnect the VCM to IDS and then connect to the DLC. Once reconnected, the VCM icon should appear in the corner of the IDS screen. If it does not, troubleshoot the IDS to VCM connection.
- d. Locate the original vehicle session when programming failed. This should be the last session used in most cases. If not, use the session created on the date that the programming failed.

NOTE: If the original session is not listed in the previous session list, click the Recycle Bin icon at the lower right of the previous session screen. This loads any deleted sessions and allows you to look through them. Double-click the session to restore it.

- e. Once the session is loaded, the failed process should resume automatically.
- f. If programming does not resume automatically, proceed to the Module Programming menu and select the previously attempted process, PMI or MR.
- g. Follow all on-screen prompts/instructions.
- h. The last screen on the IDS may list additional steps required to complete the programming process. Make sure all applicable steps listed on the screen are followed in order.



Procedure F - Turbocharger Wire Harness Taping

OVERVIEW: This procedure wraps the turbocharger wire harness with Coroplast® tape to prevent the entry/buildup of fluids and debris in the convolute which could ignite from an ignition source.

PARTS / SUPPLIES REQUIRED:

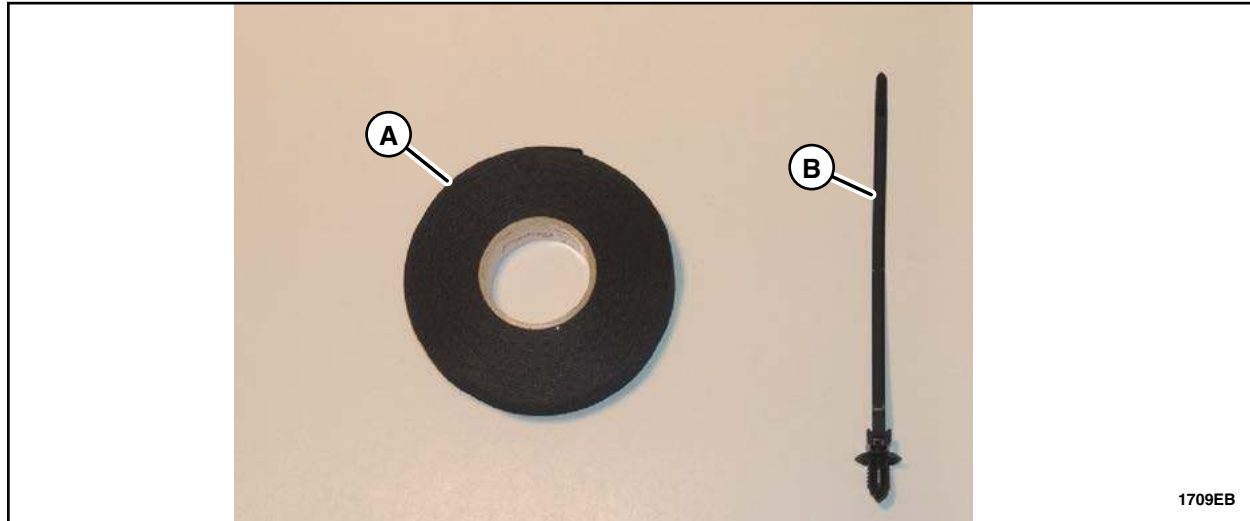

A	Coroplast® Tape
B	Wire Harness Retainer w/Tie-Strap

UNIQUE TOOL REQUIREMENTS: None

SERVICE TIPS: Tips for wrapping the harness are included in the procedure.



NOTE: Figure F1 is for reference only the harness retainers were previously disconnected in Procedure A.

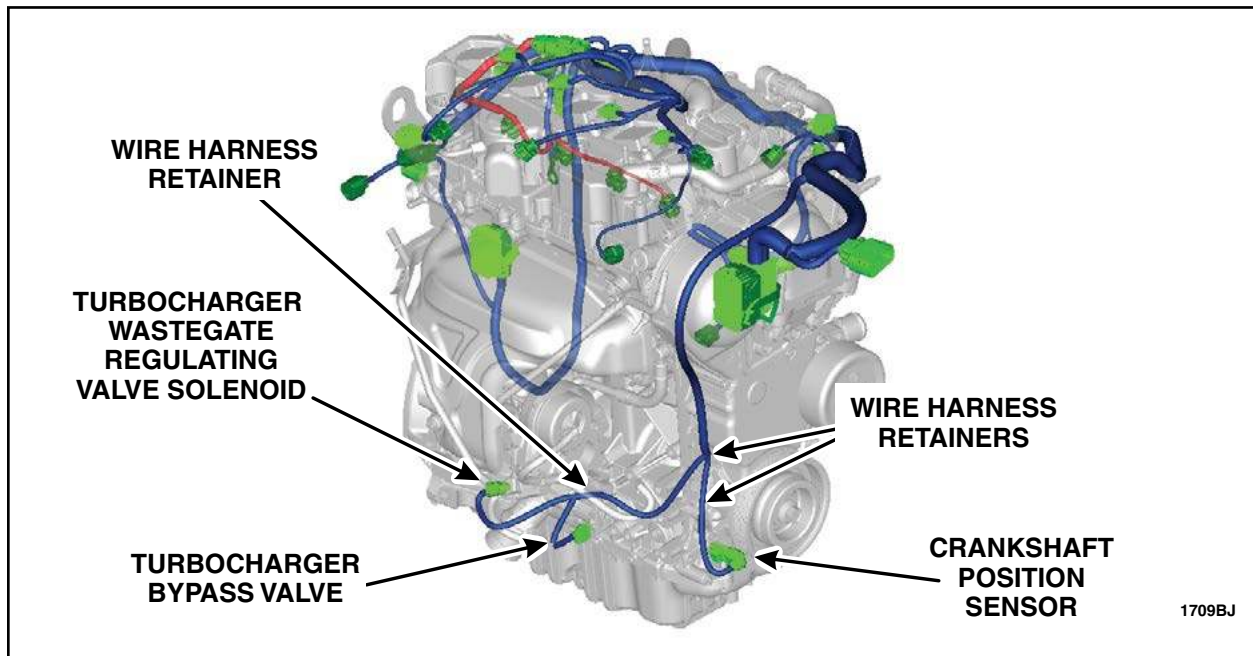

FIGURE F1

1. Route the turbocharger wire harness to the top of the engine compartment. See Figure F2.
2. If broken, replace the wire harness retainer with the *new* one supplied in the vehicle parts kit. See Figures F1 and F2.
 - Mark the wire harness retainer location before removal.



3. Wrap the turbocharger wire harness convolute with the Coroplast® tape provided in the service kit. See Figure F2.

- Start and finish each length of tape applied with three (3) initial and three (3) finishing wraps.
- Apply each wrap of tape with a 50% overwrap.
- First, wrap the takeout for the crankshaft position sensor. Begin the wrap at the connector and end this portion of wrapping by going around the main harness at the takeout. See Figure F2, (A).
- Wrap the turbocharger harness starting at the side of the harness closest to the engine. Proceed down the remaining length of harness to the turbocharger wastegate regulating valve solenoid connector and turbocharger bypass valve electrical connectors. See Figure F2, (B).

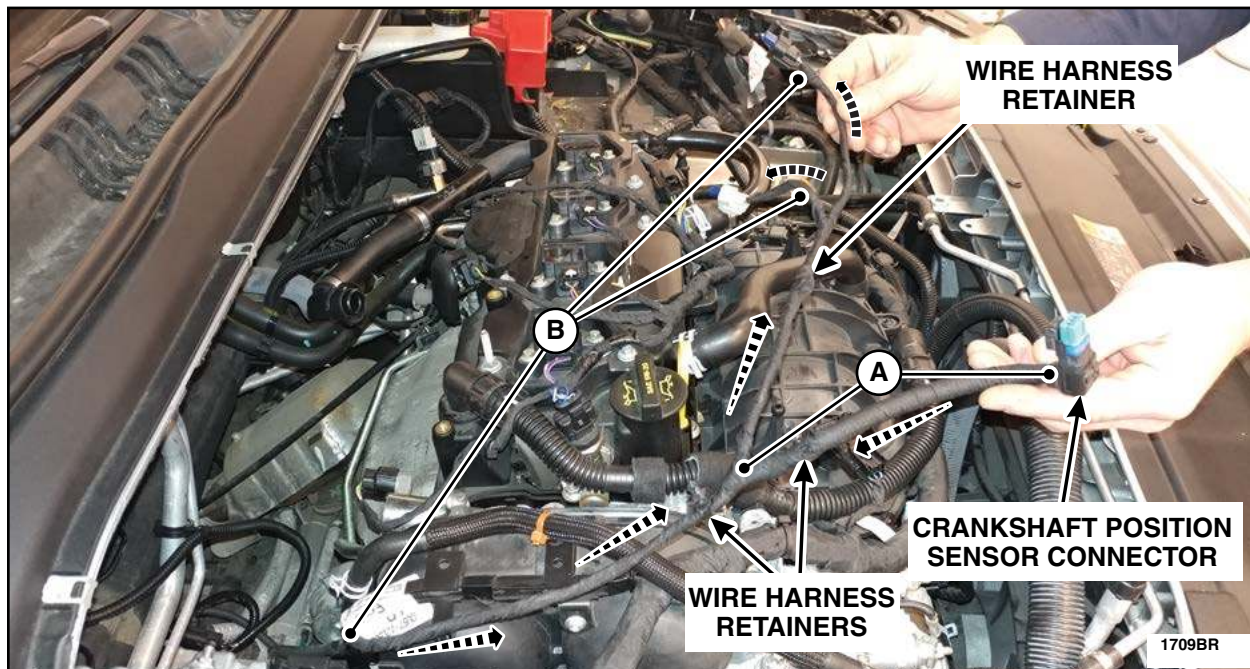

FIGURE F2

4. Route the wire harness back down to the crankshaft position sensor, turbocharger wastegate regulating valve solenoid, and turbocharger bypass valve. See Figure F1.
5. Connect the crankshaft position sensor, turbocharger wastegate regulating valve solenoid, and turbocharger bypass valve electrical connectors. Attach the wire harness retainers to the engine. See Figure F1.



Procedure G - Thermostat Replacement

OVERVIEW: An updated 82° C (179.6° F) thermostat will be installed to improve cooling system performance

PARTS / SUPPLIES REQUIRED:

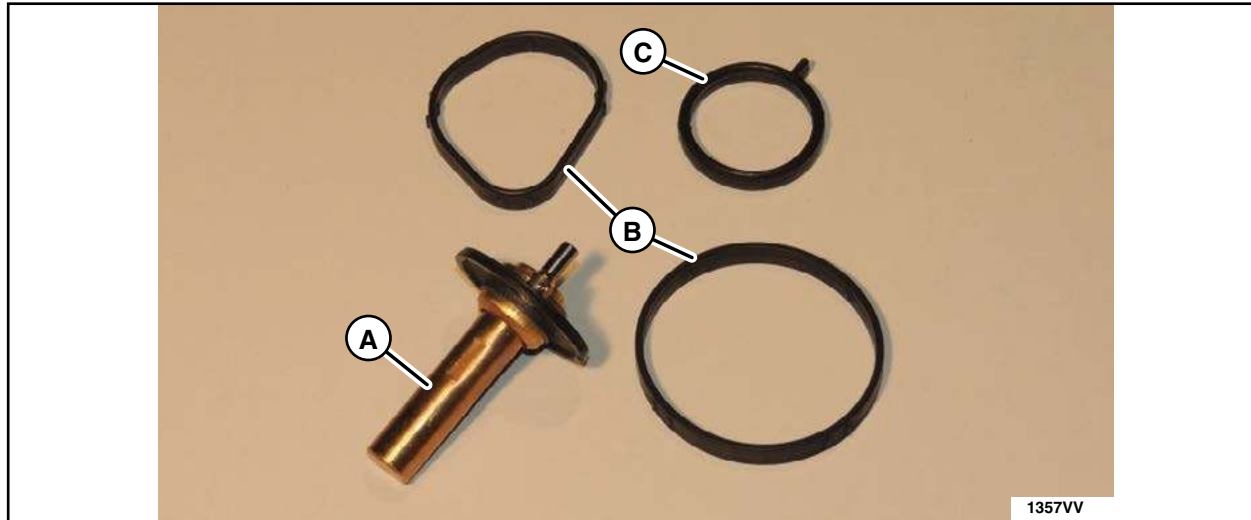

A	Thermostat
B	Thermostat housing to cylinder block O-rings (2 ea.)
C	Thermostat Housing to coolant valve O-Ring (1 ea.)

UNIQUE TOOL REQUIREMENTS: None

SERVICE TIPS: Make sure the air bleed hole in the thermostat is in the “UP” position when installed to allow any air trapped in the system to pass.



1. Remove the thermostat housing. Please follow the WSM procedures in 303-03.
 - Discard the thermostat housing gaskets.
2. Use a 13 mm (1/2 in) deep well socket to press downward on the thermostat retaining clip and rotate to remove it from the thermostat housing. Remove the thermostat spring. See Figure H2.
 - Note the position of the thermostat retaining clip and thermostat prior to removing. See Figures G1 and G2.

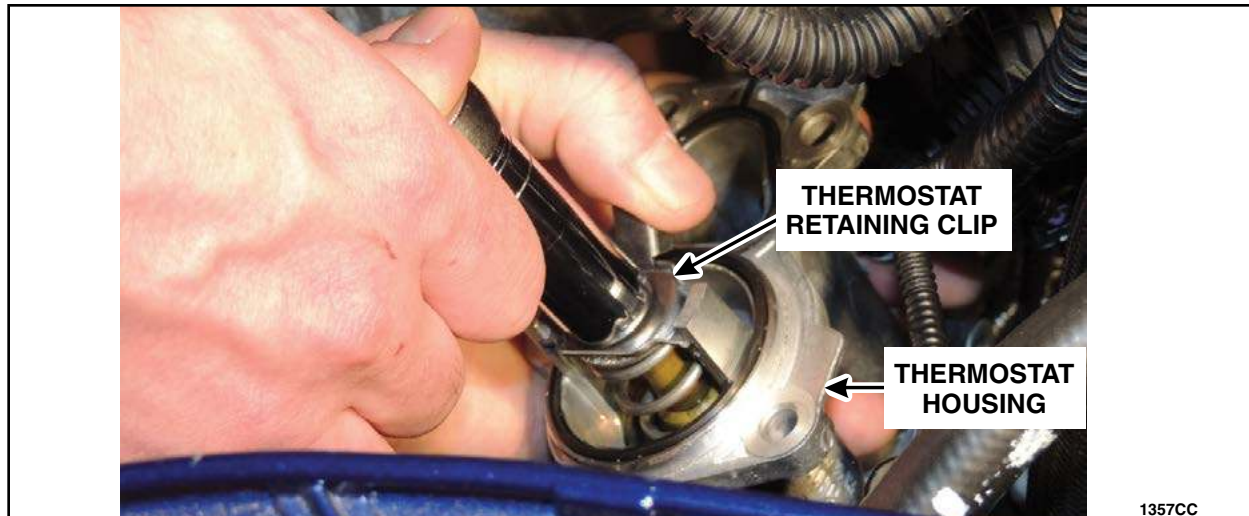

FIGURE G1

3. Remove and discard the thermostat. See Figure G2.
4. Position the *new* thermostat into the housing with the air bleed hole positioned upward. Use a 13 mm (1/2 in) deep well socket to install the thermostat spring and clip. The retaining clip must be in the same orientation that it was in prior to removal. See Figures G2 and G3.

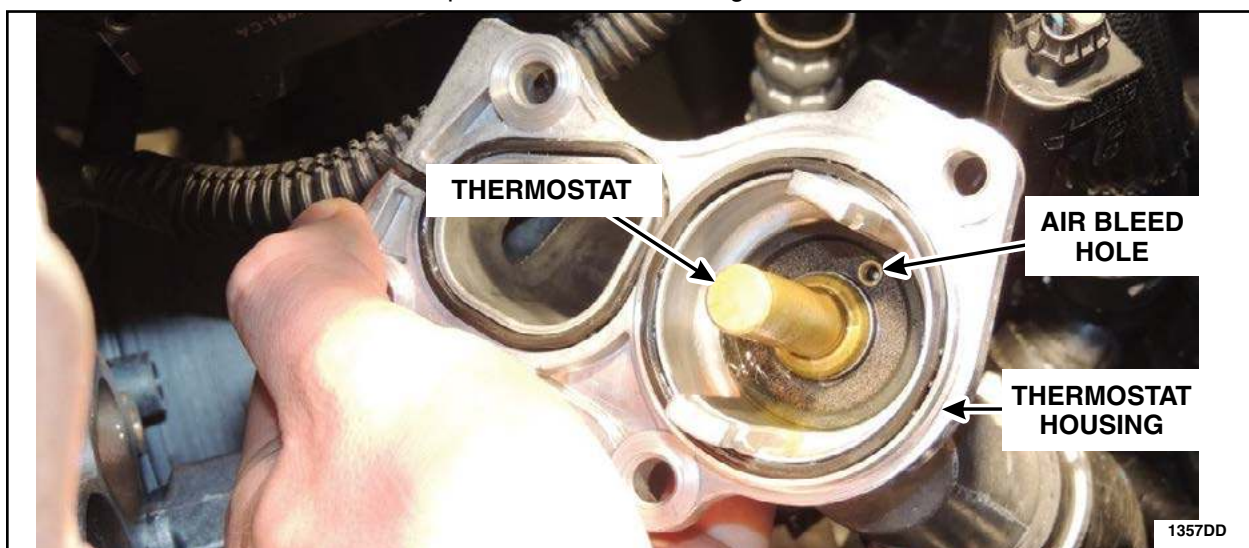

FIGURE G2



NOTICE: Do not use pliers or other tools to install the thermostat.

NOTE: The thermostat retaining clip must be installed in the position as shown. See Figure G3.

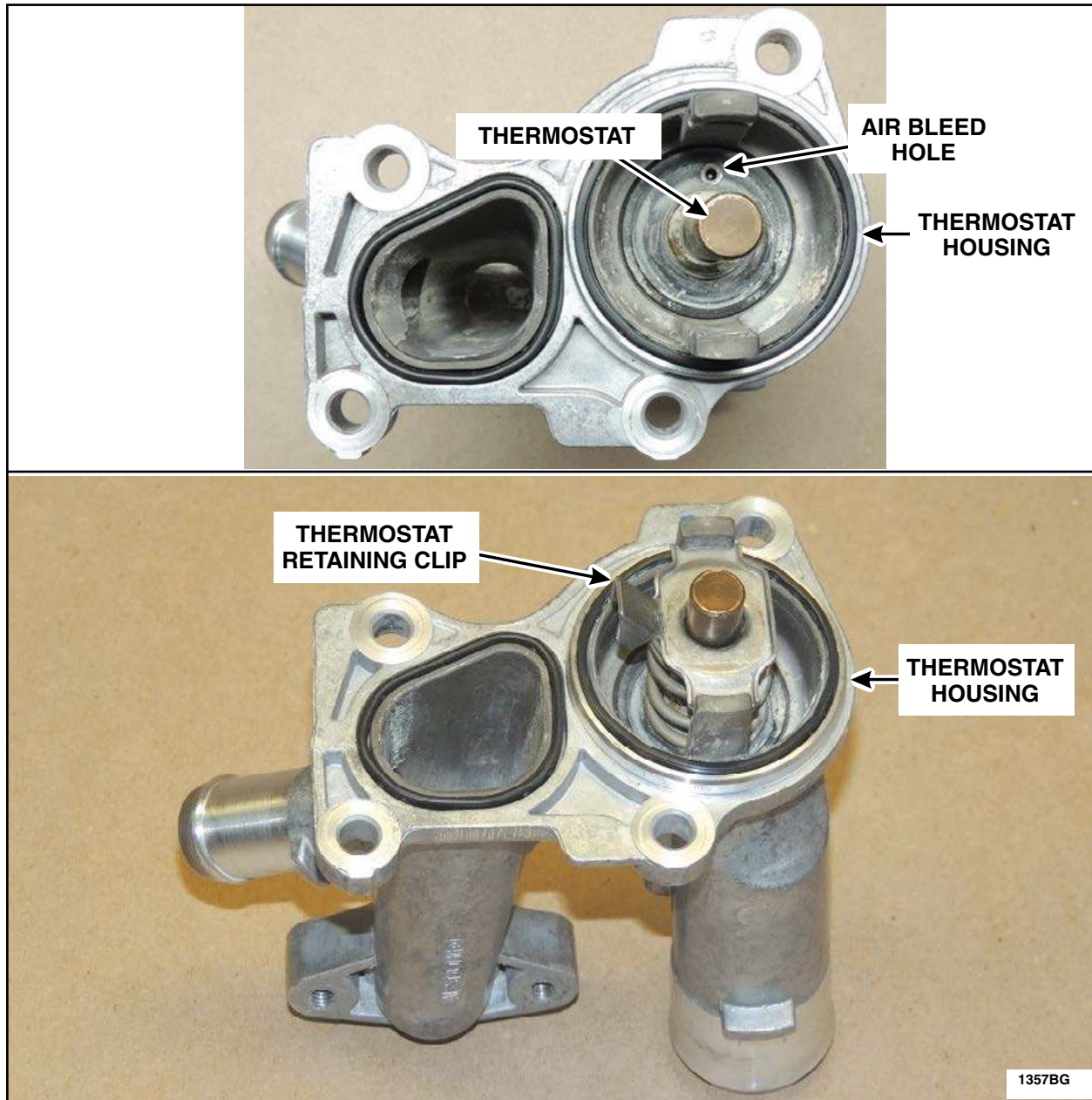

FIGURE G3

5. Install the *new* thermostat housing gaskets and install the thermostat housing. Please follow the WSM procedures in 303-03.

- Do not re-connect the degas bottle to thermostat housing coolant hose at this time.
- Do not re-connect the generator battery cable and electrical connector to the generator at this time.
- Do not refill the engine coolant at this time.



Procedure H - Engine Coolant Bypass Valve Replacement

OVERVIEW: The engine coolant bypass valve is being replaced in this procedure.

PARTS / SUPPLIES REQUIRED:

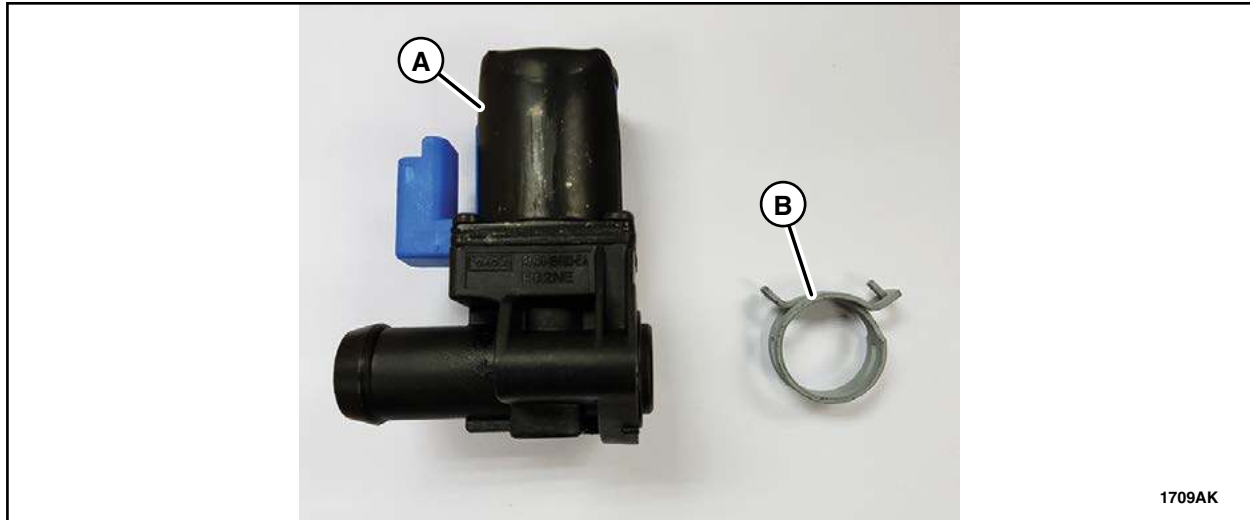

A	Engine Coolant Bypass Valve
B	Hose Clamp

UNIQUE TOOL REQUIREMENTS: None

SERVICE TIPS: None



1. Disconnect the engine coolant bypass valve electrical connector. See Figure H1.

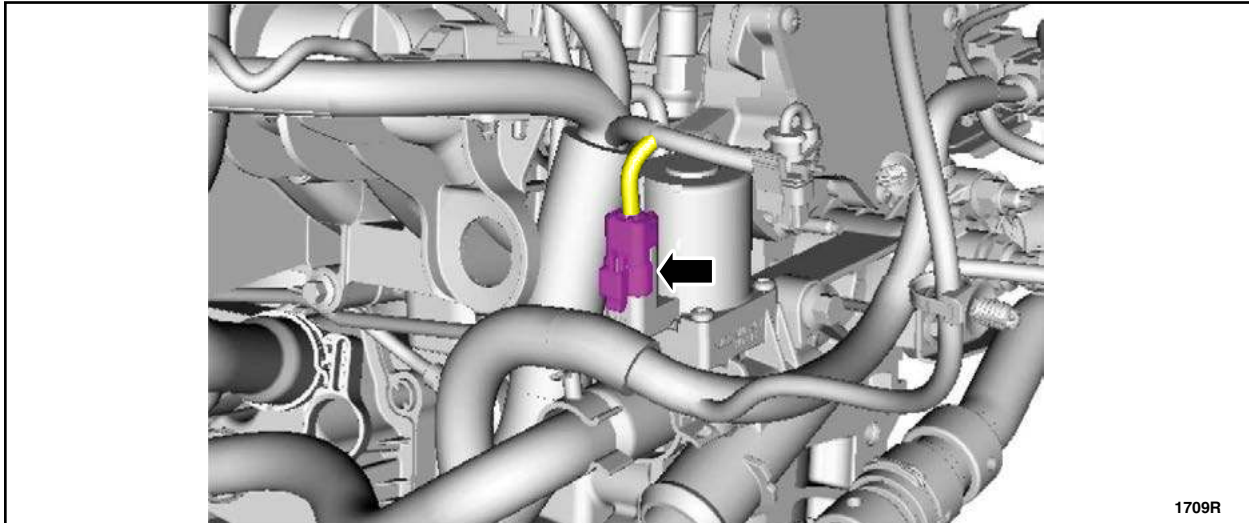

FIGURE H1

2. Release the clamp and disconnect the coolant hose. Discard the clamp. See Figure H2.

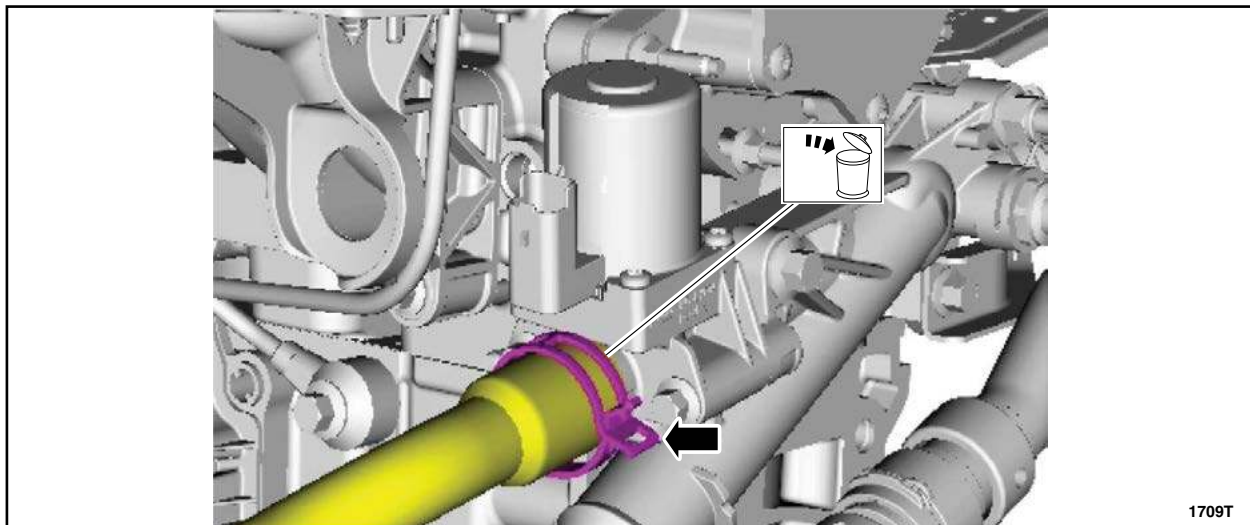

FIGURE H2



3. Remove the bolts from the engine coolant bypass valve. Remove and discard the valve and O-ring seal. See Figure H3.

- Tighten to 89 lb.in (10 Nm).

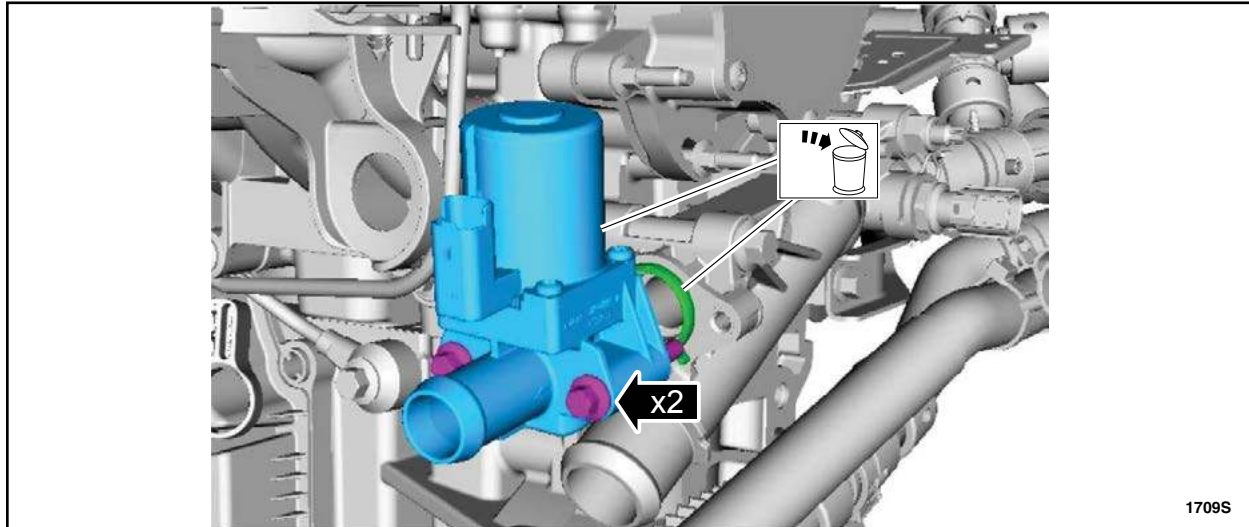

FIGURE H3

4. Install a *new* engine coolant bypass valve and O-ring seal by reversing the removal procedure.



Procedure I - Coolant Hose Replacement

OVERVIEW: In this procedure, the coolant hose that runs between the degas bottle and thermostat quick connect T-fitting is replaced with an updated hose that allows for connection to the turbocharger coolant return line and the *new* coolant stand-pipe. The engine degas tube is also being replaced with an updated assembly that allows for connection to the radiator degas hose and degas bottle.

PARTS / SUPPLIES REQUIRED:

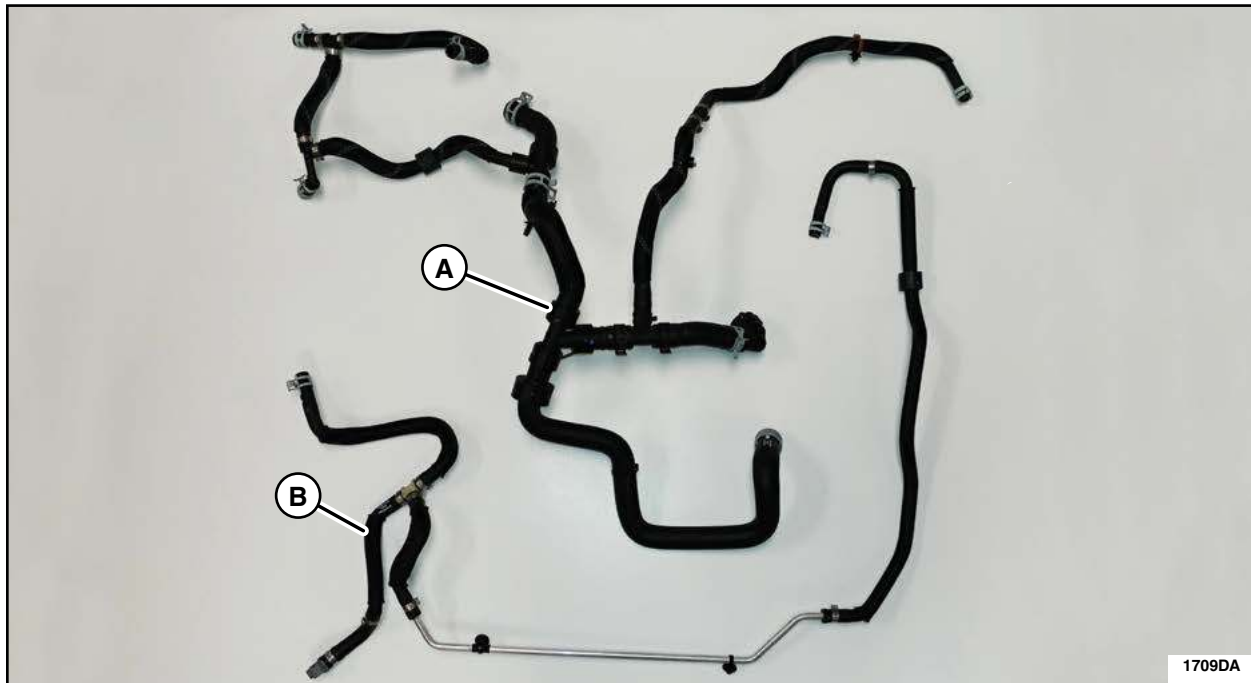

A	Coolant Degas Bottle to Thermostat Housing Hose
B	Engine Degas Tube

UNIQUE TOOL REQUIREMENTS: None



SERVICE TIPS: The degas bottle hose assembly will need to be separated (an upper and lower portion) at the reusable clamp to allow it to be fitted to the vehicle. The clamp will be re-used during the installation. The new coolant hoses and connection points are called out below. See Figures I1A and I1B.

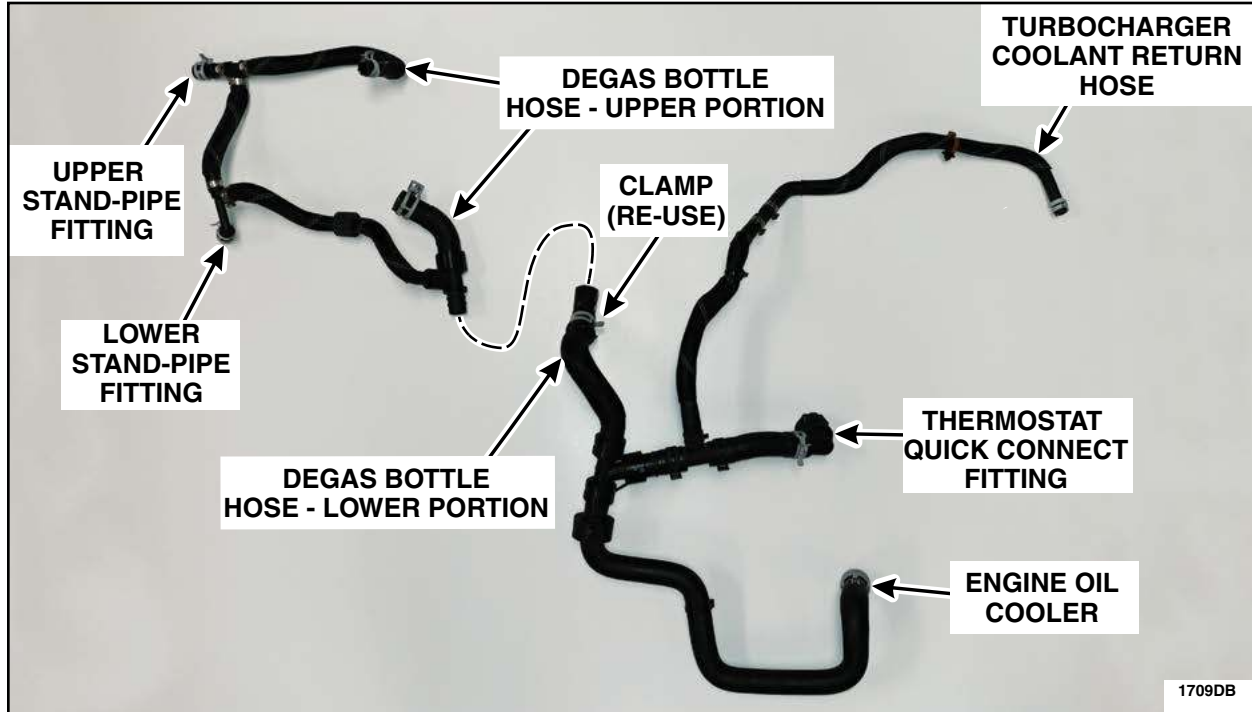

FIGURE I1A



FIGURE I1B



1. Remove and discard the degas bottle and cap. See Figure I2.

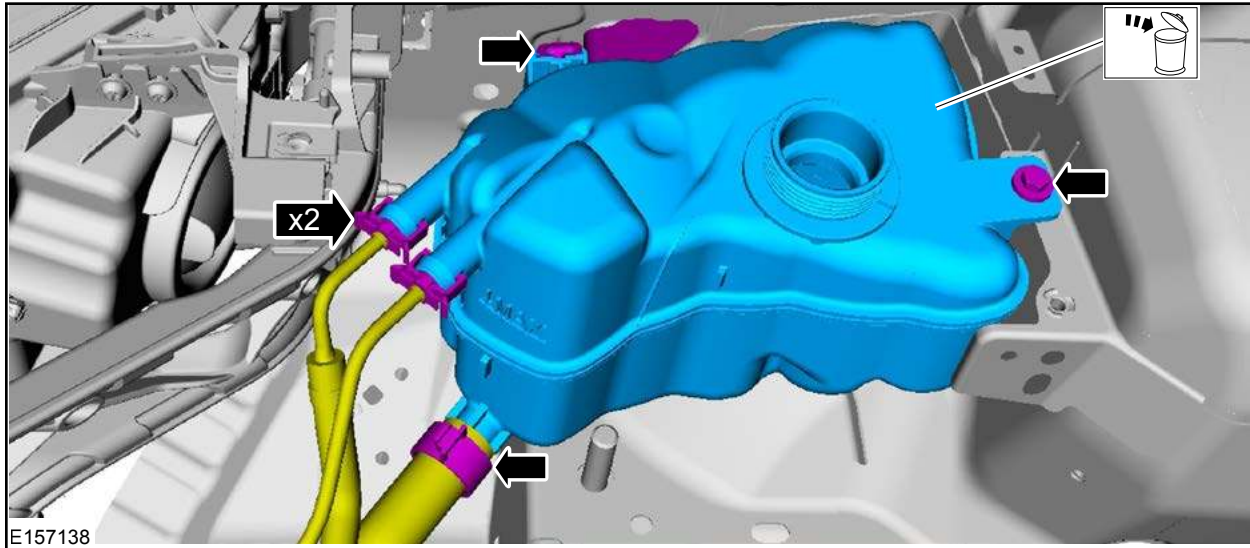

FIGURE I2

2. Disconnect and position aside the turbocharger coolant return hose. See Figure I3.

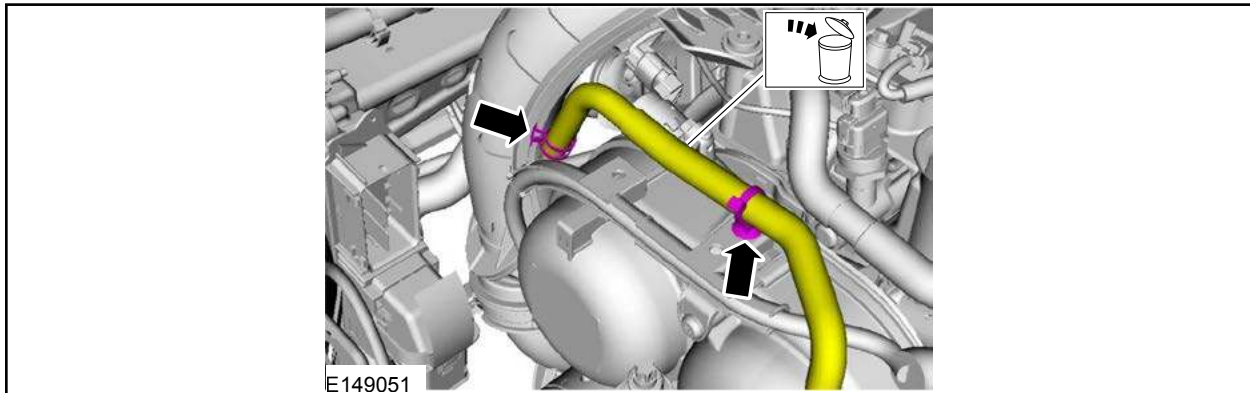

FIGURE I3

3. Disconnect the degas bottle coolant hose from the radiator and discard. See Figure I4.

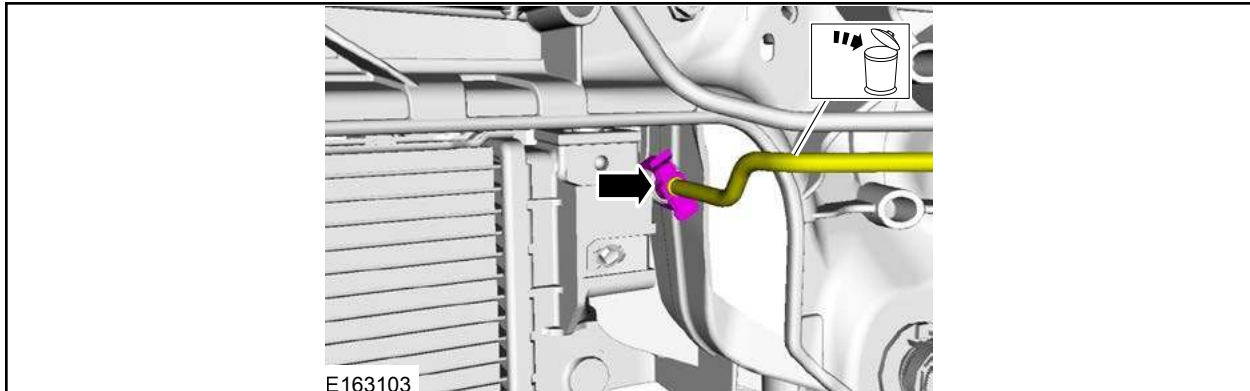

FIGURE I4



4. Detach the retainers, remove and discard the engine degas tube assembly. See Figure I5.

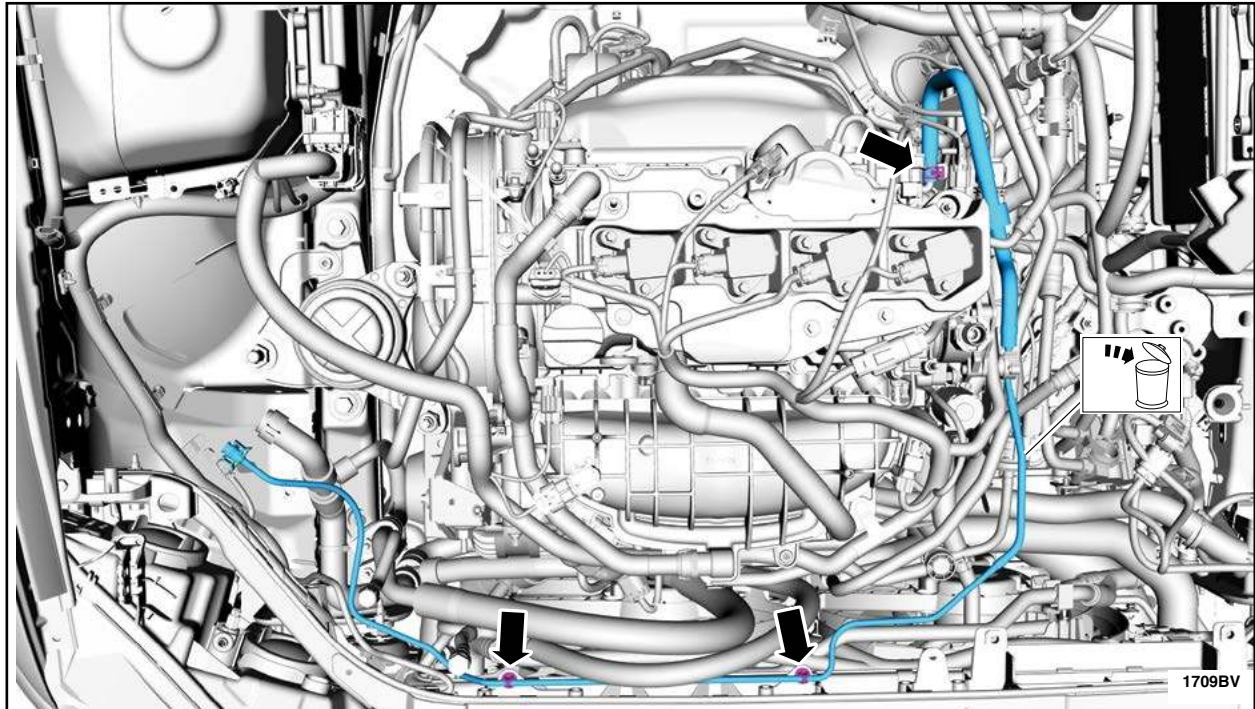

FIGURE I5

5. Detach the retainer, then route the degas hose assembly out from under the A/C line, to allow for easier removal. See Figure I6.

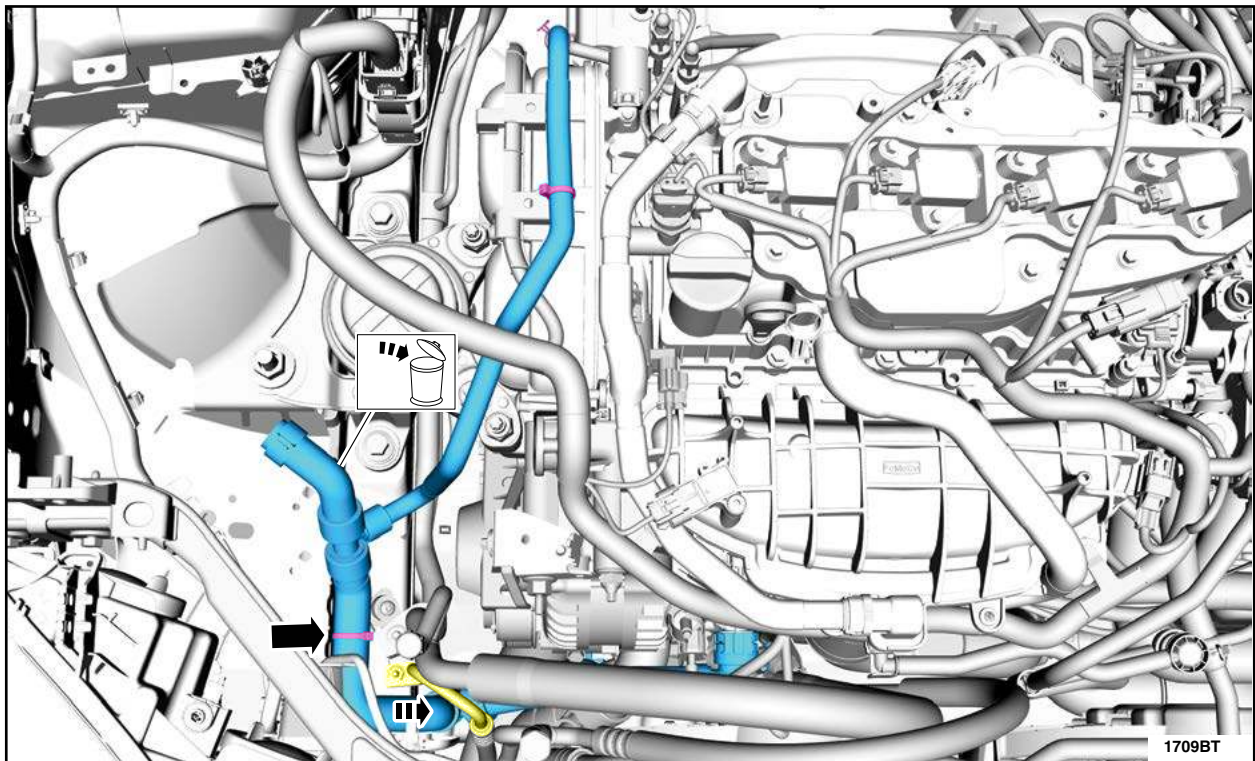

FIGURE I6



6. Detach the retaining clip and disconnect the degas bottle hose from the engine oil cooler assembly. Remove and discard the degas hose assembly. See Figure 17.

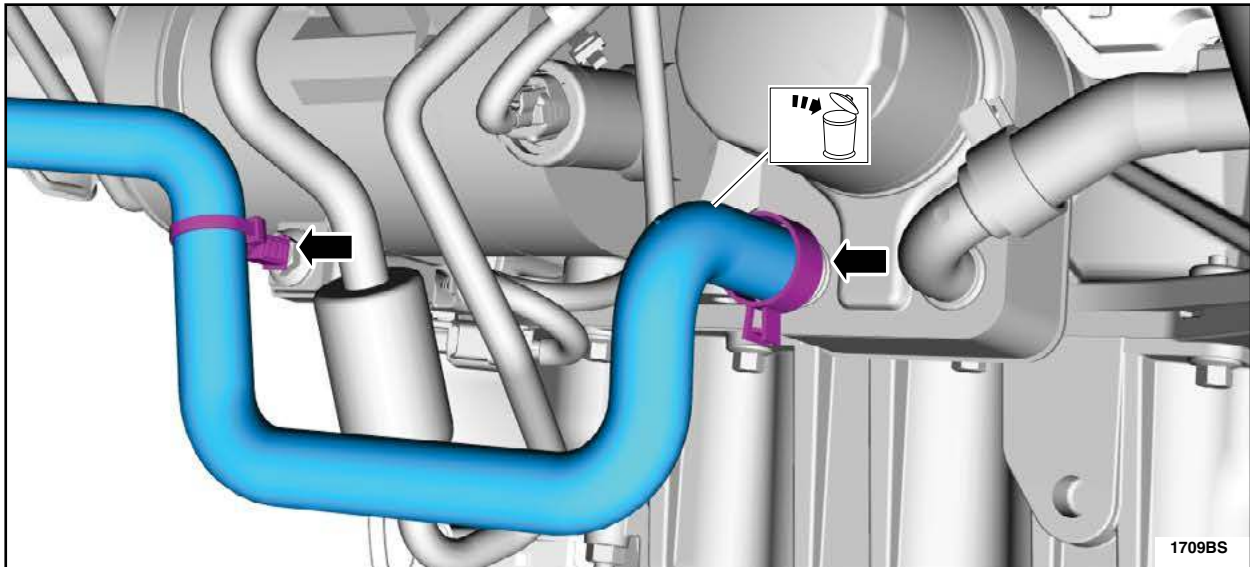

FIGURE 17



NOTE: Lubricating the new coolant hoses with coolant will aid in easier installation.

NOTE: Ensure the inside of the hose fittings are free from dirt and debris.

7. Install the *new* lower portion of the degas bottle hose. See Figure I8.

1. Route the turbocharger coolant return hose upward to the top of the engine.
2. Position the lower portion of the degas bottle hose. Attach the lower retaining clip.
3. Connect the lower hose to the engine oil cooler.

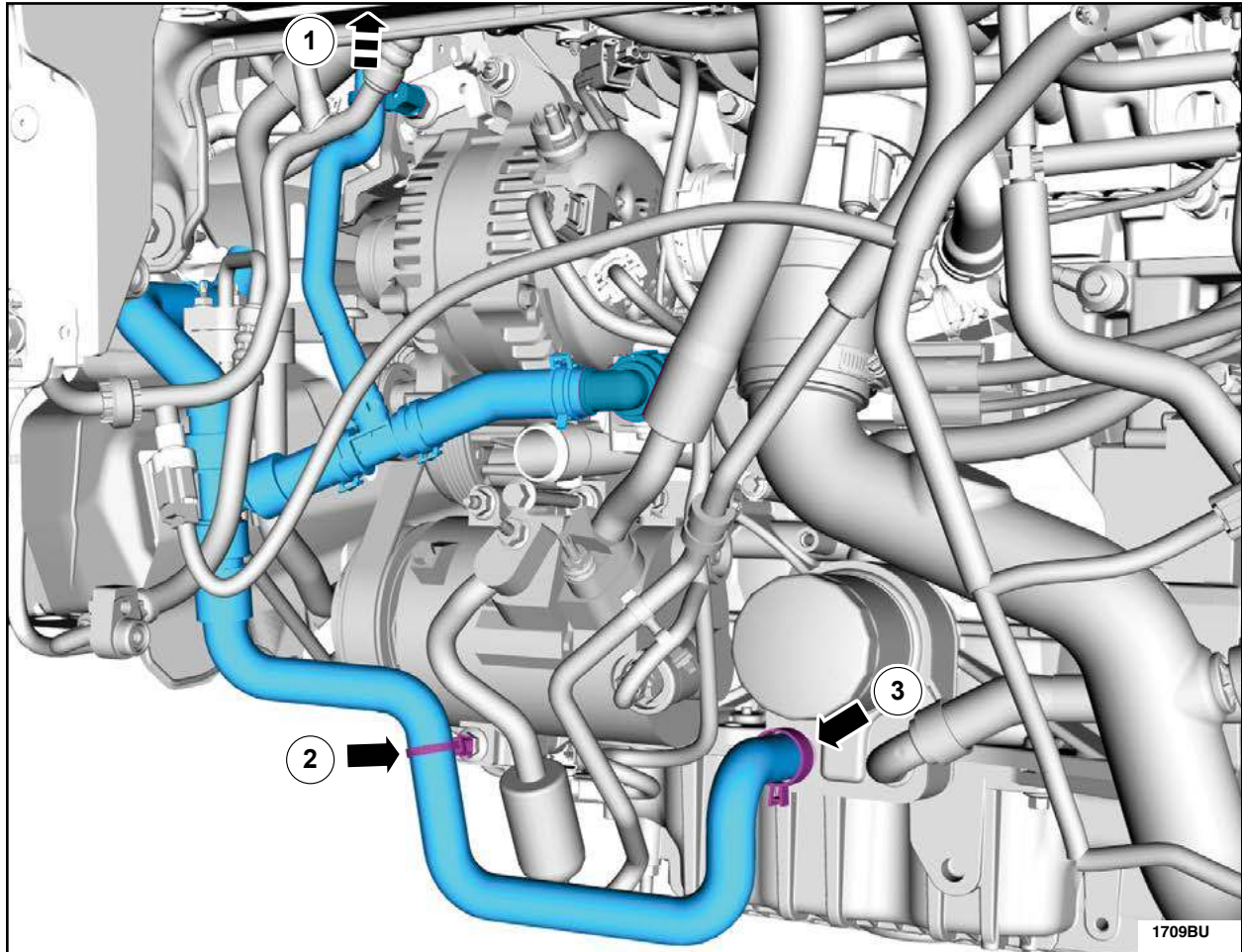

FIGURE I8



8. Connect the thermostat quick connect fitting to the thermostat housing. See Figure I9.

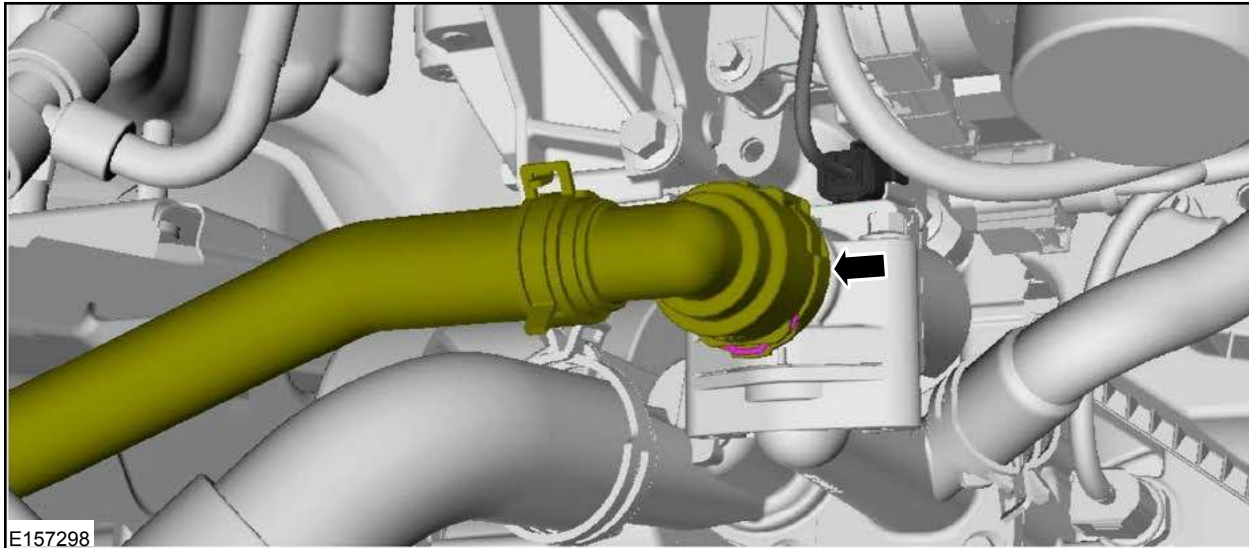

FIGURE I9

9. Route the lower degas hose upward around the A/C line and to the degas bottle area. Install the lower degas hose push pin retainers to the A/C line bracket and generator stud. See Figure I10.
10. Connect the *new* turbocharger coolant return hose and attach the retaining clip. See Figure I10.

NOTE: The coolant stand-pipe is shown installed for reference only. It will be installed later in this procedure.

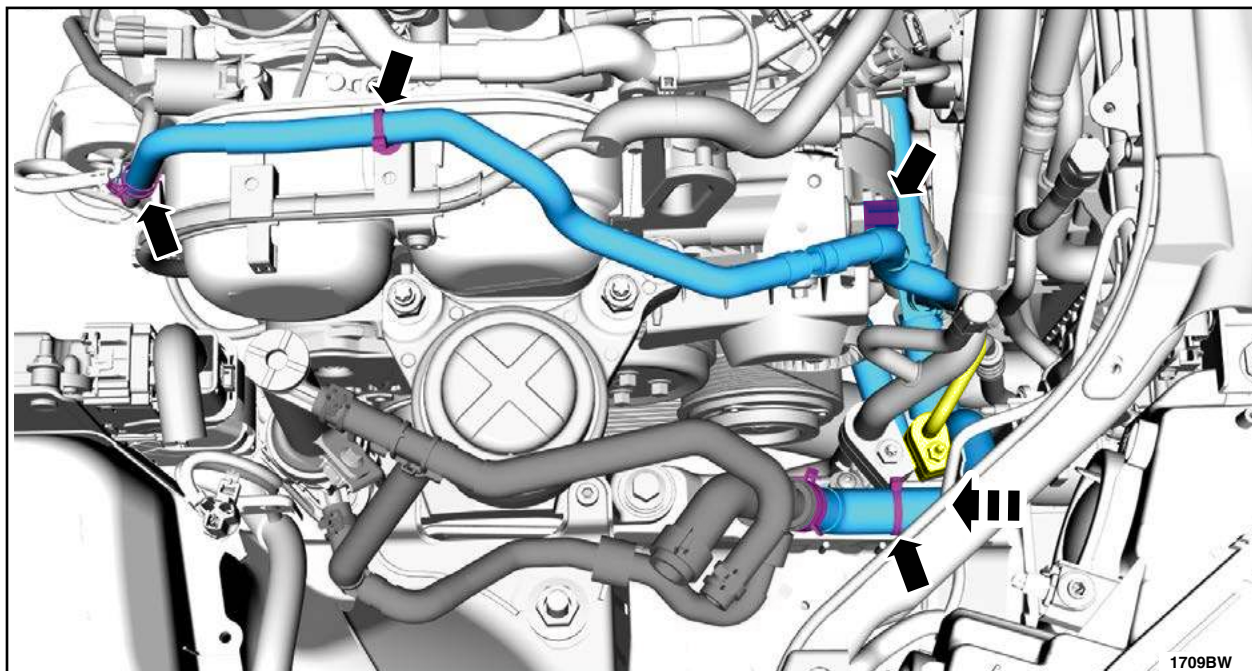

FIGURE I10



11. Install and connect the *new* upper portion of the *new* degas hose, to the previously installed *new* lower degas hose. Align the hose with the marks and install the hose clamp. See Figure I11.

NOTE: The coolant stand-pipe is shown installed for reference only. It will be installed later in this procedure.

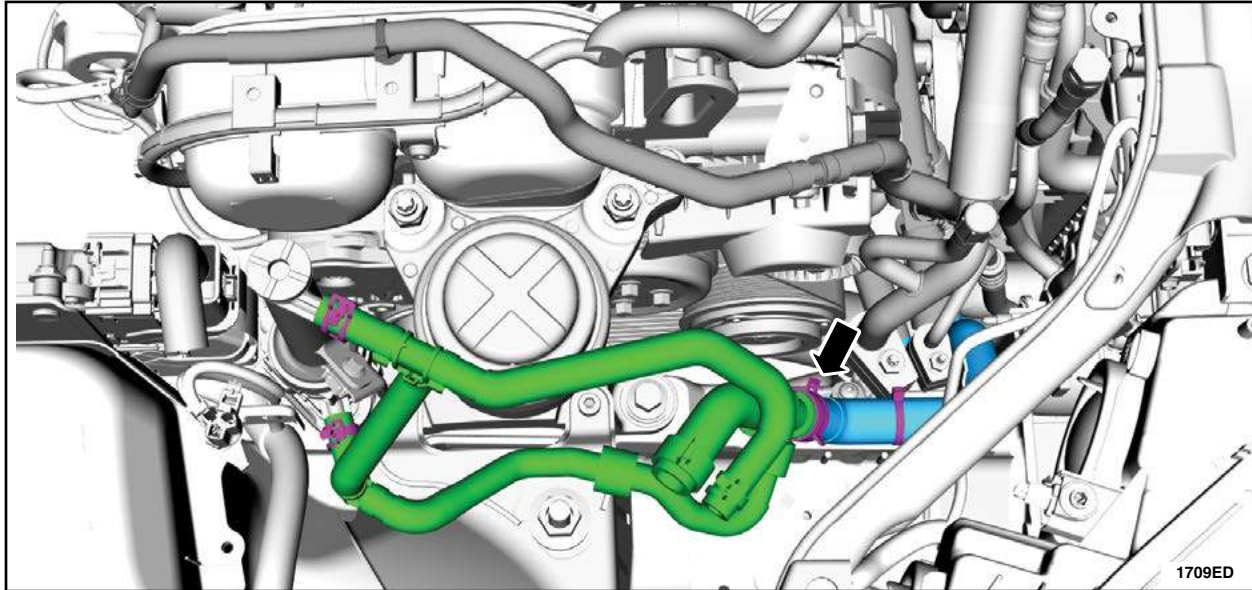

FIGURE I11

12. Install the *new* engine degas tube assembly and connect to the back of the engine. Connect the engine degas tube assembly to the radiator. Attach the retaining clips. See Figure I12.

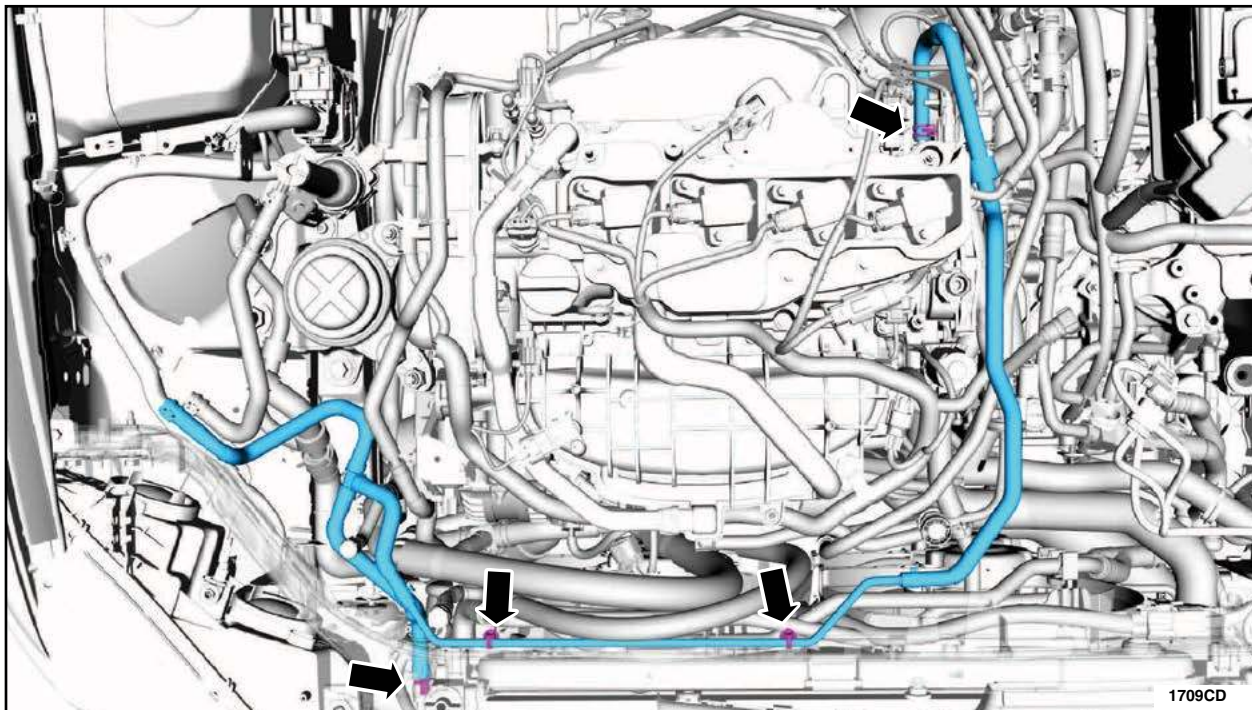

FIGURE I12



Procedure J - Coolant Stand-pipe, Degas Bottle and Cap Installation

OVERVIEW: The coolant stand-pipe provides coolant level information to the PCM and IPC via the CAN network, this prevents overheat issues due to low coolant level by informing the driver when the coolant level is low. The coolant stand-pipe and bracket is installed using the engine mount rear fixing bolt. On installation, the wiring harness is routed across the engine bay wiring loom and the related coolant hoses are attached.

PARTS / SUPPLIES REQUIRED:

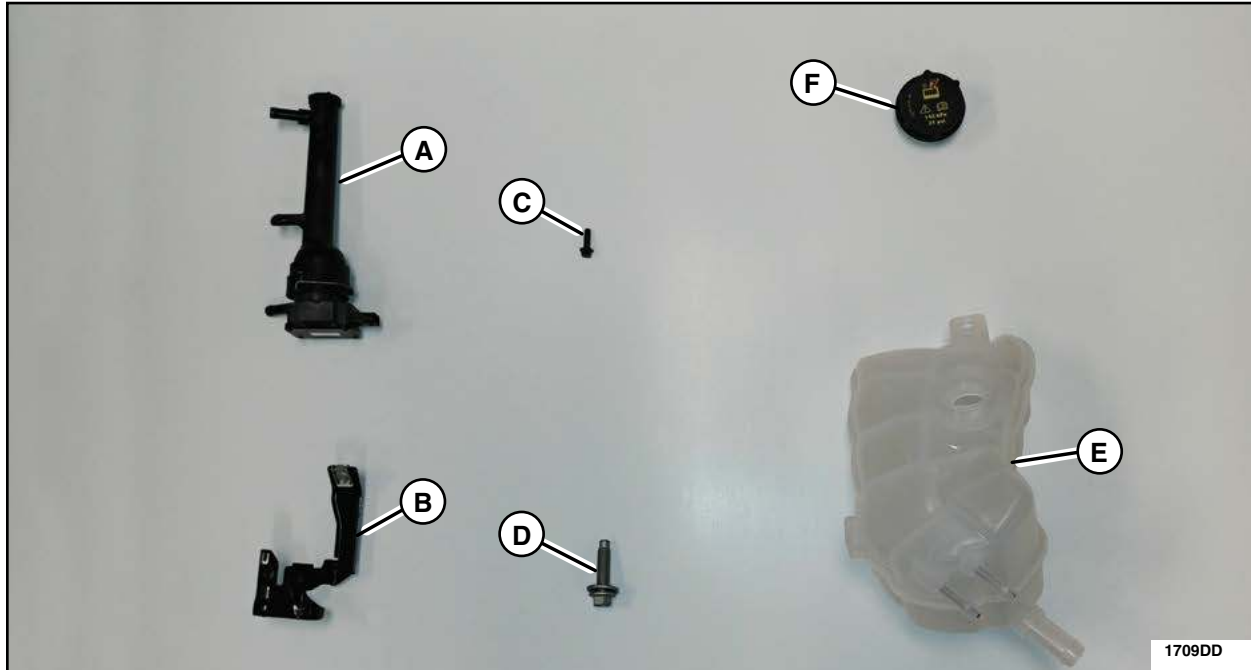

A	Coolant Stand-pipe (Includes Coolant Level Sensor)
B	Coolant Stand-pipe Bracket
C	Coolant Stand-pipe to Bracket Bolt
D	Engine Mount Bolt
E	Degas Bottle
F	Degas Bottle Cap



1. Remove the rear engine mount bolt and take note of the bolt hole location. The bolt hole must be centered with the engine mount hole to allow for proper installation of the coolant stand-pipe bracket. See Figure J1.
 - If the bolt hole is centered with the engine mount, then powertrain assembly mount neutralizing will not be required. Proceed to Step 2.
 - If the hole is not centered, carry out the powertrain assembly mount neutralizing procedure. Please follow the WSM procedures in Section 303-00. Then proceed to Step 2.

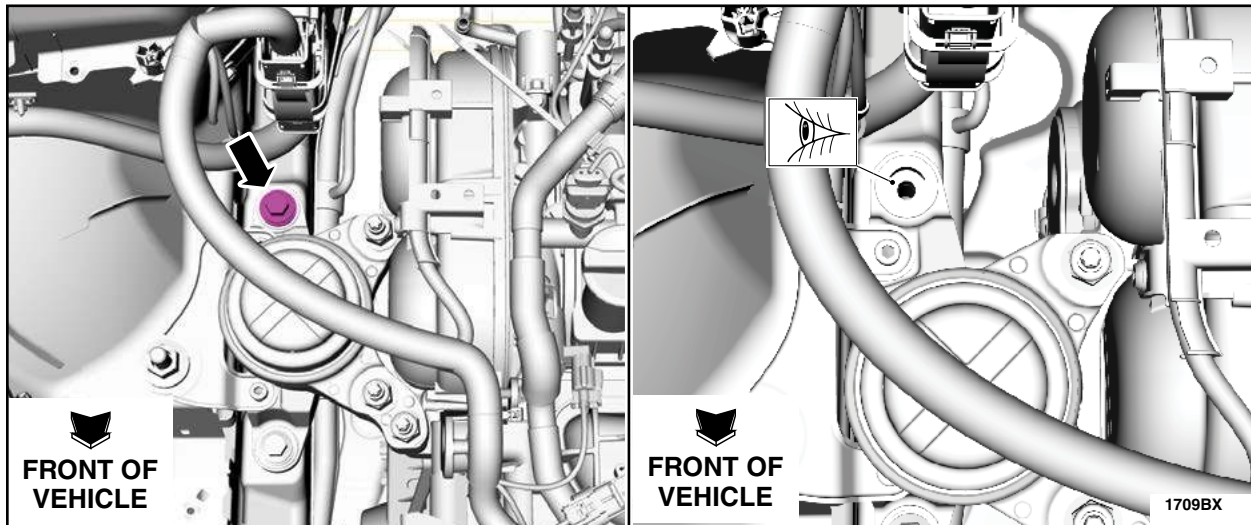

FIGURE J1

2. **NOTICE:** The bolt hole must be centered with the engine mount hole to allow for proper installation of the coolant stand-pipe bracket. **DO NOT** use power tools to re-install the bolt.

Position the coolant stand-pipe bracket on the engine mount. The bolt will center the bracket and the locating tab on the bottom of the bracket should be pressed against the engine mount. Hand start the bolt and then tighten both engine mount retaining bolts at this time. See Figure J2.

- Tighten to 90 Nm (66 lb.ft).

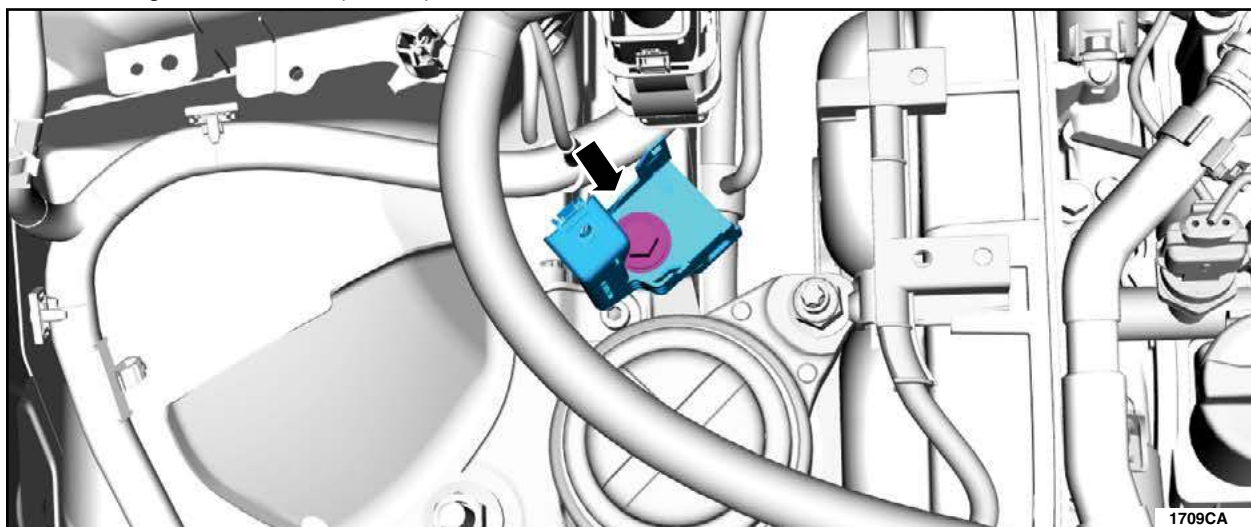

FIGURE J2



3. Install the coolant stand-pipe to the bracket. See Figure J3.

1. Push the coolant stand-pipe fully down in to position on the bracket.
2. Tighten the bolt to 5 Nm (44 lb.in).

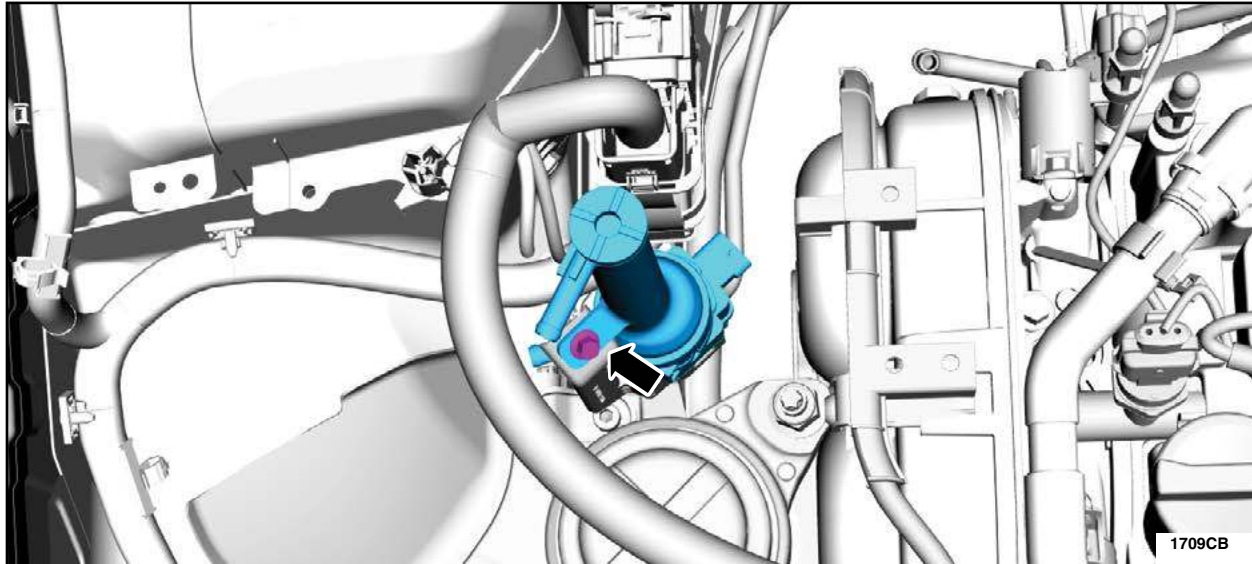

FIGURE J3

NOTE: Lubricating the new coolant hoses with coolant will aid in easier installation.

NOTE: When connecting the coolant hoses to the stand-pipe ensure the hoses are fully installed and meet the hose stops, before securing in place with hose clamps.

NOTE: Make sure that no strain is placed on the coolant hose and pipe.

4. Connect the *new* coolant hoses to the *new* coolant stand-pipe. See Figure J4.

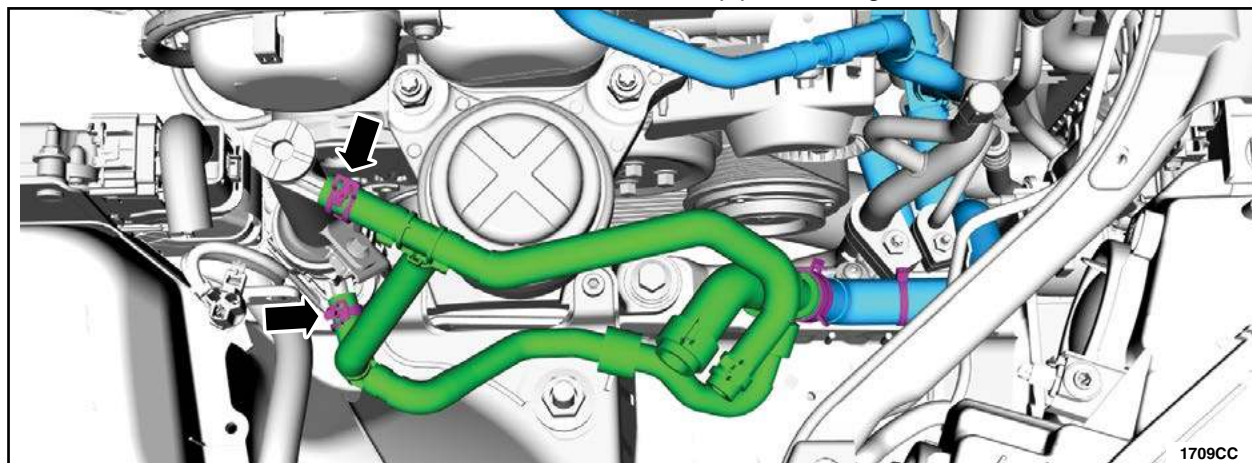

FIGURE J4



5. Connect coolant stand-pipe wiring harness to the coolant stand-pipe. See Figure J5.

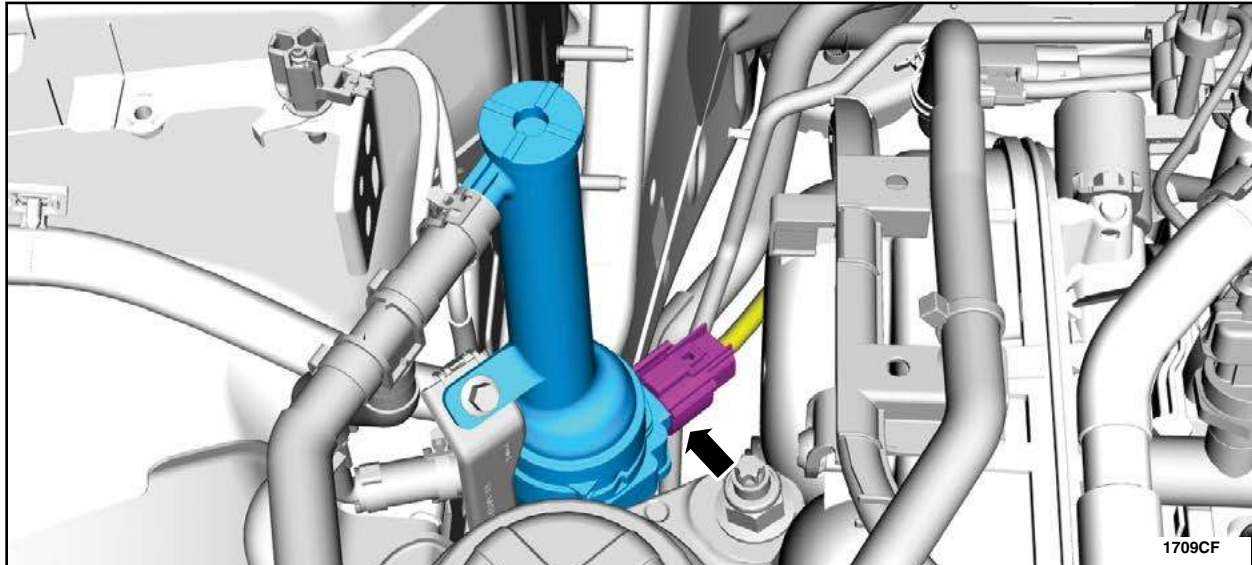

FIGURE J5

6. **NOTE:** Do Not fill the cooling system at this time.

Install the *new* degas bottle, install the bolt and cap. Connect the coolant hoses. See Figure J6.

- Tighten to 9 Nm (80 lb.in).

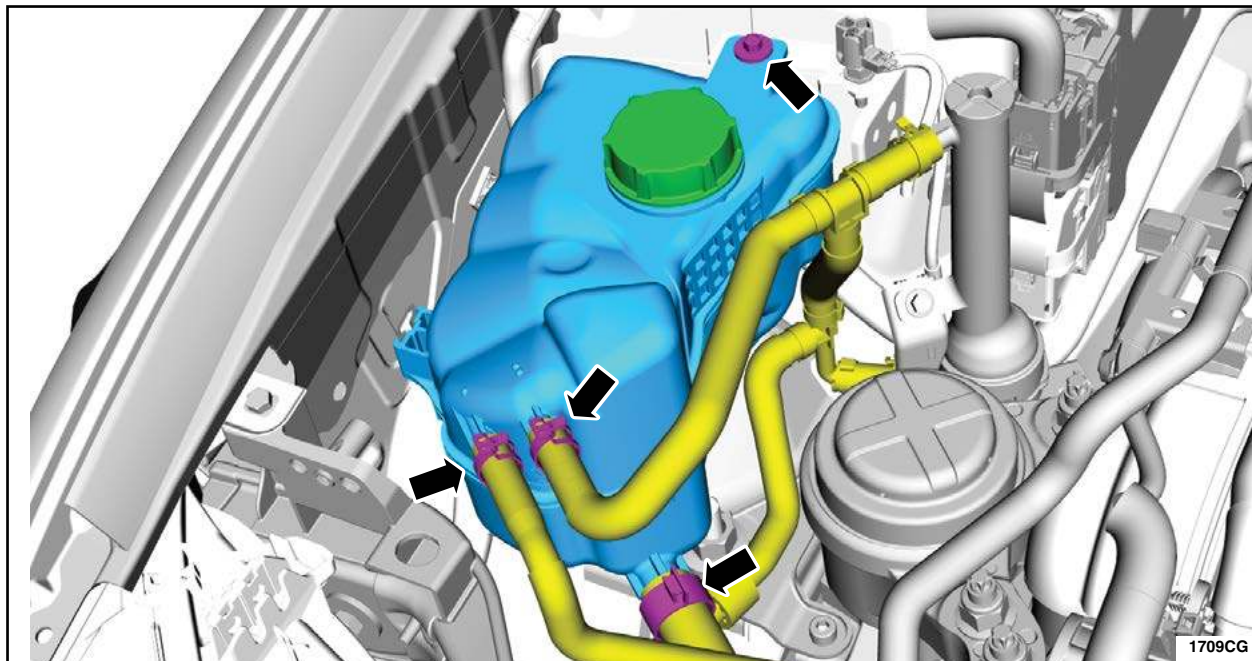

FIGURE J6

NOTE: Check the status of the IPC reprogramming progress.



Procedure L - Vehicle Reassembly, PCV Tube Retention, and Powertrain Control Module (PCM) Reprogramming

OVERVIEW: The vehicle is reassembled, the cooling system is vacuum filled, pressure tested and bled; and a PCV tube retainer is installed. The PCM is reprogrammed and coolant level sensor operation is validated.

PARTS / SUPPLIES REQUIRED:

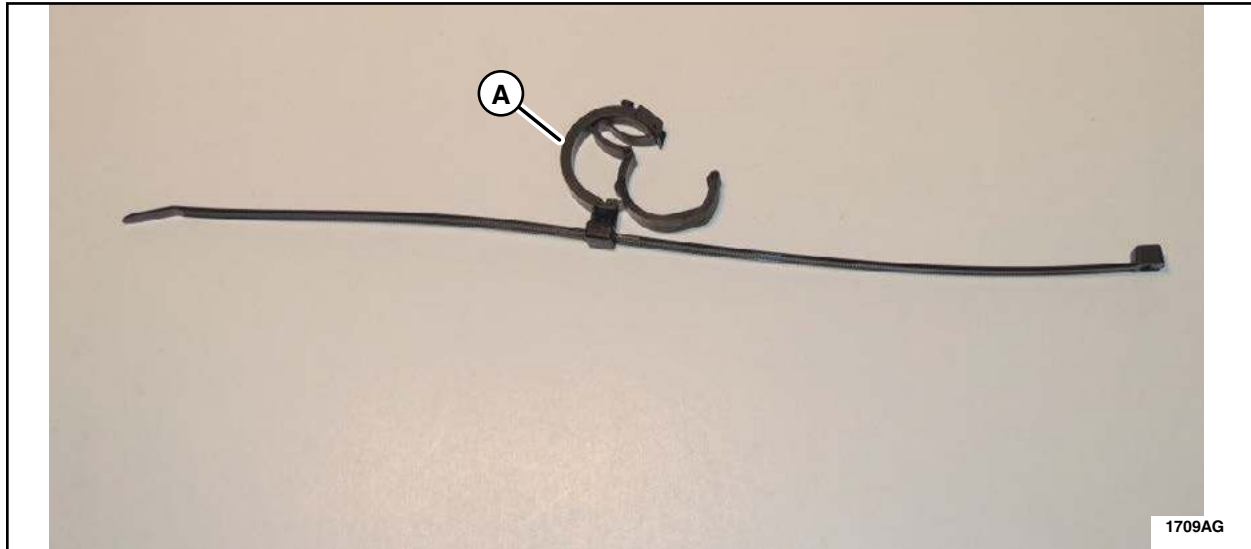

A	PCV Tube Retainer / Tie strap
B	Motorcraft® Metal Brake Parts Cleaner (PM-4-A or PM-4-B) (Dealer Procured) (Not Shown)
C	Motorcraft® Orange Antifreeze / Coolant Prediluted (VC-3DIL-B (U.S.) CVC-3DIL-B (Canada) / WSS-M97B44-D2) (Dealer Procured) (Not Shown)

UNIQUE TOOL REQUIREMENTS: Vacuum Filling Tool, Hydrometer and/or Refractometer, Cooling System Pressure Tester

SERVICE TIPS: Follow procedure steps to verify proper coolant fill.



NOTE: This procedure contains unique steps for reassembly, including installation of *new* components.

1. Disconnect the battery cable to ground. Please follow the WSM procedures in Section 414-01.
2. Position the PCM back onto the bracket and install the three nuts. See Figure A7.
 - Tighten to 10 Nm (89 lb-in).
3. Uncover the generator battery cable end then connect to the generator, install the nut. See Figure D5.
 - Tighten to 15 Nm (133 lb-in).
4. Connect the generator electrical connector. See Figure D5.
5. Connect the battery negative cable to ground. Please follow the WSM procedures in Section 414-01.

NOTE: Remove protective covers that were placed over the turbocharger air intake system before re-installing components.

6. Install the turbocharger inlet pipe and connect the PCV hose to the turbocharger inlet pipe. See Figure A3.
 - Tighten the turbocharger inlet pipe fasteners to 5 Nm (44 lb-in).
 - Tighten the turbocharger inlet pipe-to-turbocharger clamp to 5 Nm (44 lb-in).
7. Install the air cleaner and outlet pipe assembly. See Figures A1 and A2.
 - a. Tighten the bolts and clamp to 5 Nm (44 lb-in).
 - b. Connect the vent tube to the air cleaner outlet pipe
 - c. Connect the EVAP line to the air tube center section.
 - d. Connect the mass air flow electrical connector.
8. Vacuum fill the cooling system. Refer to WSM Section 303-03 for coolant specifications.
 - Do not bleed the cooling system at this time.
 - Coolant level should be filled to the "MAX" mark on the degas bottle.
9. Install a coolant pressure tester with adapter onto the degas bottle. Pressurize to 138 kPa (20 psi). Once pressure stabilizes, pressure should hold at 138 kPa (20 psi) for a minimum of 2 minutes.
 - If pressure test fails, the source of pressure loss must be identified and repaired as appropriate before proceeding. Retest the cooling system, if required.



10. Install the PCV tube retainer / tie strap provided in the vehicle parts kit. See Figure L1.
 - a. Attach the clamp onto the PCV tube and secure.
 - b. Wrap the tie strap around the air intake tube center section and tighten.
 - c. Trim the excess length from the tie strap.

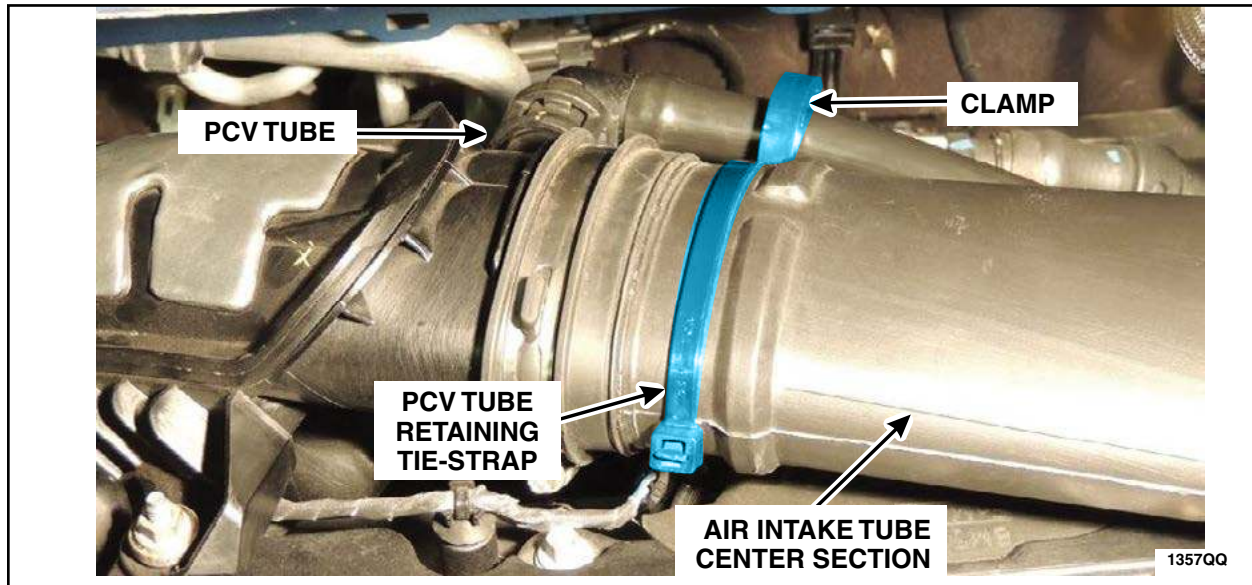

FIGURE L1

11. Install the front under-body air deflector and retainers. See Figure A5.
12. Bleed the cooling system. Please follow the WSM procedures in Section 303-03.



13. Reprogram the PCM using IDS release 108.03 or higher. For additional information, Refer to "Procedure E" (Important Information for Module Reprogramming).
14. Reprogram the Gateway Module (GWM) using IDS release 108.03 or higher. For additional information, Refer to "Procedure E" (Important Information for Module Reprogramming).
15. Using IDS select "Coolant Level Sensor Check". See Figure L2.

- Follow the on screen instructions to complete the "Coolant Level Sensor Check" procedure.

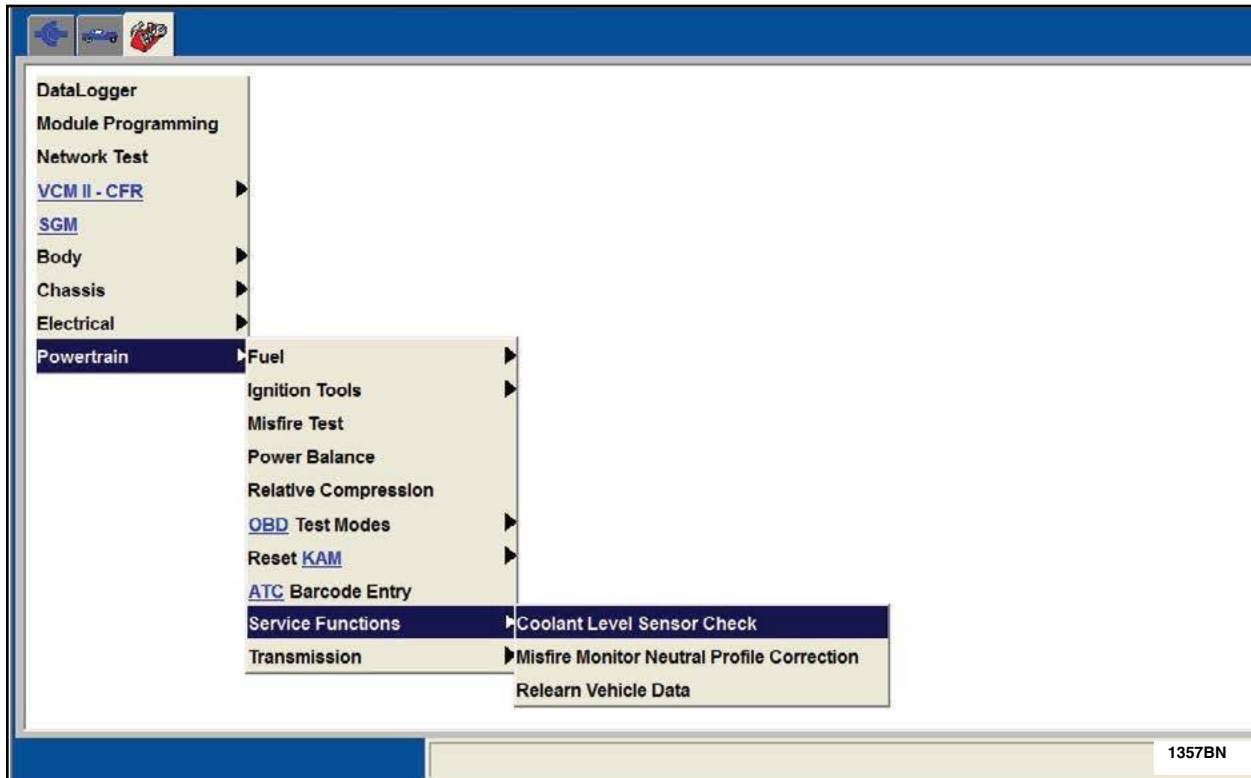
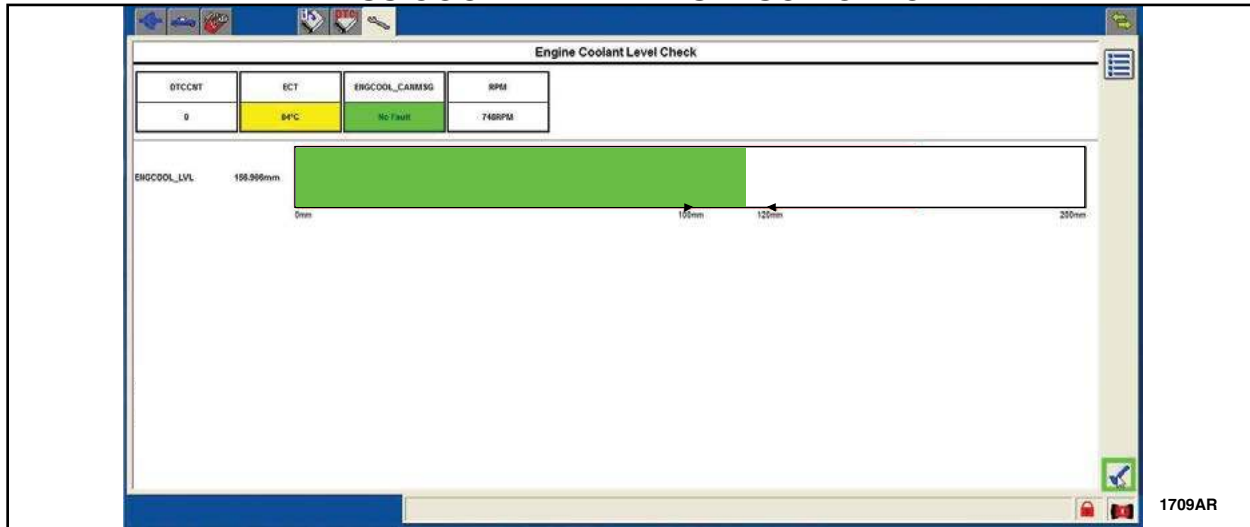

FIGURE L2



PASS COOLANT LEVEL SENSOR CHECK



DOES NOT PASS COOLANT LEVEL SENSOR CHECK

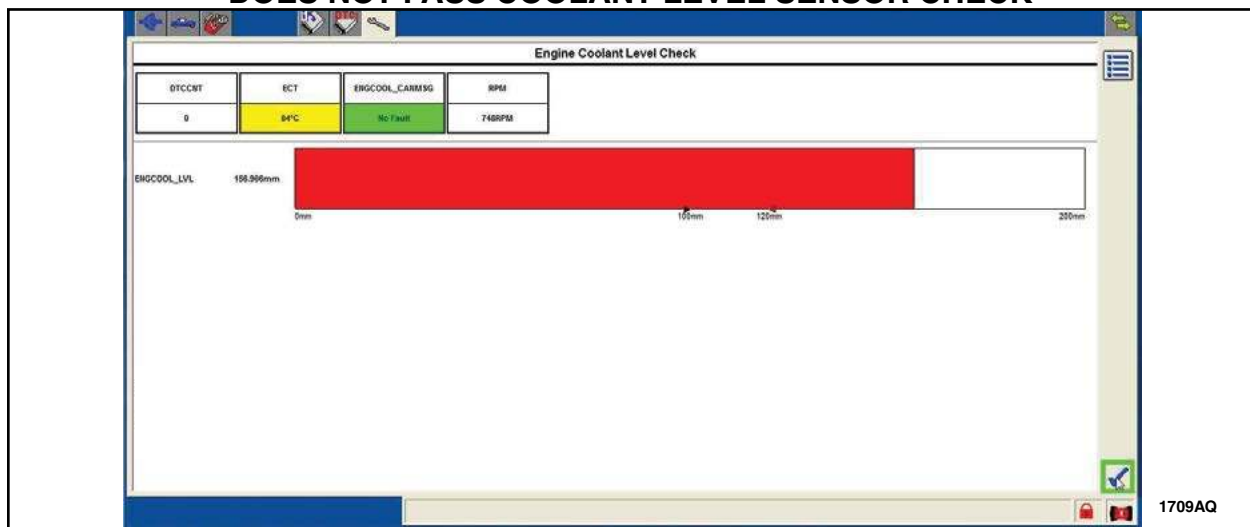

NOTE: If the coolant level is too high, additional cooling system bleeding is needed. If it is proving difficult to bleed, it may be necessary to drive the vehicle up to 12.5 Miles (20 km) to remove the air from the system.

16. Check coolant concentration using the hydrometer/refractometer to make sure it is at 50%.
17. Remove the portable battery charger.
18. Install the engine appearance cover.
19. Perform any other open recalls.
20. Coolant level should be filled to the "MAX" mark on the degas bottle once the engine is cold, prior to returning the vehicle to the customer.

