

12L

Art. 11140

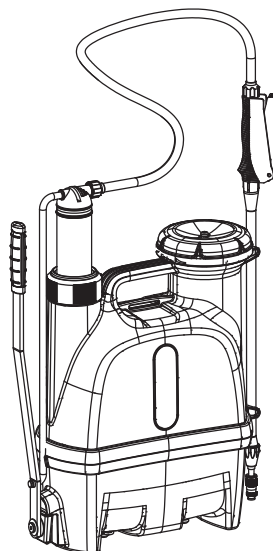
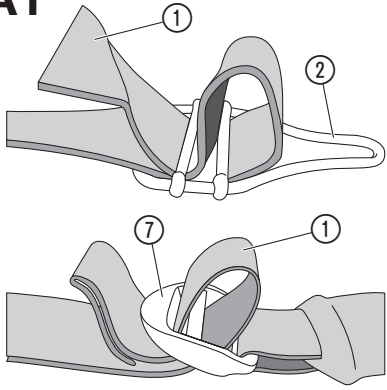
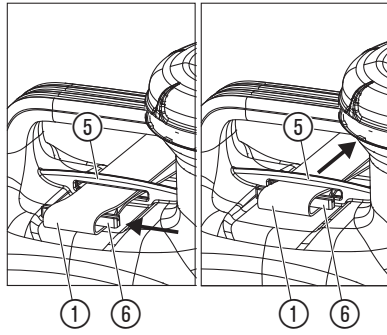
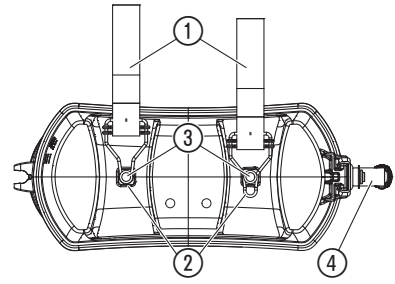
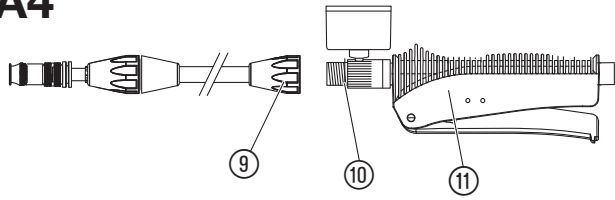
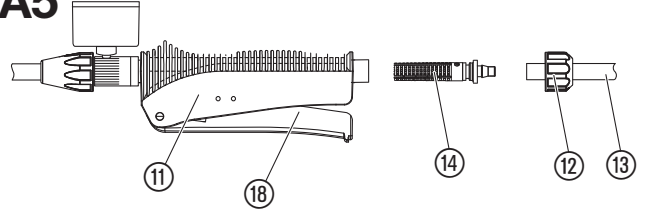
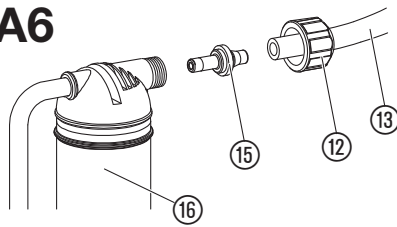
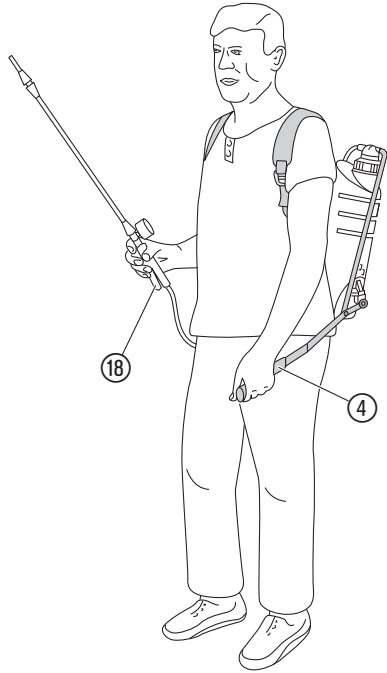
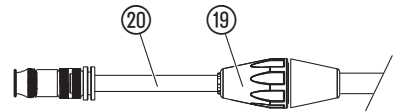
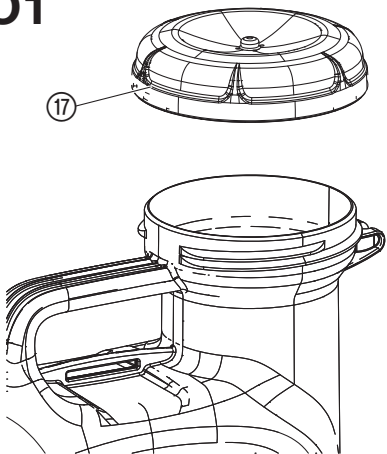
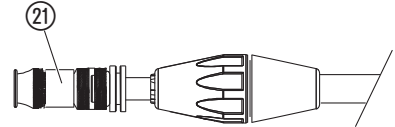
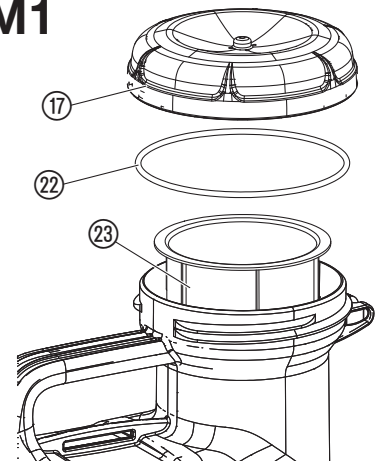
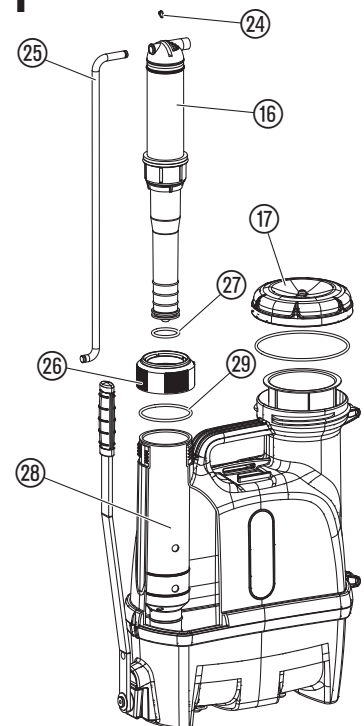

EN Operator's manual
Backpack Sprayer

A1**A2****A3****A4****A5****A6****O2****O3****O1****O4****M1****T1**

EN GARDENA Backpack Sprayer 12L

Translation of the original instructions.

Please read the operating instructions carefully and observe the notes given. Use these operating instructions to familiarise yourself with the Backpack Sprayer, its proper use and the notes on safety.

For safety reasons, children and young people under 16 as well as anyone who is not familiar with these operating instructions should not use the product. Never operate the product when you are tired, ill or under the influence of alcohol, drugs or medicine.

Read the operator's manual carefully before use and keep for future reference.

Intended use:

The **GARDENA Backpack Sprayer** is intended for distributing solvent-free liquid pesticides¹⁾, herbicides¹⁾, fertilisers¹⁾, window cleaners¹⁾, and car wax¹⁾ in domestic gardens and allotments. It must not be used in public places, parks, sport arenas, or in agriculture or forestry. Compliance with the specifications in this operating manual is a requirement for the proper use of the Backpack Sprayer.

¹⁾ According to the Plant Protection Law as well as the Detergents and Cleaning Agents Law, only approved agents may be used (authorised specialist dealers).

Please note:

Due to the risk of physical injury, the GARDENA Backpack Sprayer must not be used for spraying substances other than those specified by GARDENA. Also, no acids, disinfectants or impregnators, aggressive and solvent-containing cleaning agents, petrol or spray oil may be sprayed.

1. SAFETY

Danger of physical injuries:

Never open the Backpack Sprayer or unscrew the sprayer handle when the Pressure Sprayer is still pressurised.

When spraying insecticides, herbicides and fungicides or other liquid plant protection products, you must comply with all special precautionary measures specified by the manufacturer of the product you are using.

Always release the pressure completely before opening the Backpack Sprayer by pressing the pushbutton of the sprayer handle.

DANGER! Small parts can be easily swallowed. There is also a risk that the polybag can suffocate toddlers. Keep toddlers away when you assemble the product.

Operation:

CAUTION: The tank may only be filled with a maximum of 12 litres liquid.

Check the Backpack Sprayer for possible damages before each use. Never leave your Backpack Sprayer unattended or for long periods when full and pressurised.

Keep the product out of the reach of children. You are responsible for the safety of others.

Keep your Backpack Sprayer away from heat sources and hot environments.

The tank cap is equipped with a pressure relief valve. This valve draws in air to equalise the pressure inside the tank and prevents liquid leaking out if the Backpack Sprayer falls over.

Cleaning:

Release the pressure after each use by pressing the pushbutton of the sprayer handle, empty the container, clean it carefully and rinse with clear water. Then leave the Backpack Sprayer open and allow it to dry.

Do not dispose of residual fluids in the sewerage system (local disposal systems).

Always clean the Backpack Sprayer before using a different product to avoid chemical reactions.

To prevent reactions with the products you are using, never use aggressive cleaning agents that contain solvent or petrol.

We recommend that you have your Backpack Sprayer thoroughly inspected (preferably at a GARDENA Service Centre) after using it for 5 years.

Storage:

Before storing, loosen the tank cap and always empty your Backpack Sprayer completely (also after cleaning with water). Store away from frost. Make sure that the product is protected from direct sunlight. The product may heat up.

2. ASSEMBLY

To assemble the carrying strap [Fig. A1/A2/A3]:

1. Pull each unstitched end of the carrying strap ① approx. 2 to 3 cm through the metal buckles ②.
2. Pull the carrying strap ① through the opening ⑤ under the carrying handle so that the strap adjuster ⑦ is at the front.
3. Push the strap lock ⑥ sideways into the carrying strap ①.
4. Pull back the carrying strap ① until the strap lock ⑥ prevents the carrying strap from sliding out.
5. Pull the metal buckles ② onto the lugs ③ on the bottom of the Backpack Sprayer until it audibly engages.

If you are right-handed the pump lever ④ should be on the left-hand side so that you can hold the spray lance in your right hand. For left-handers correspondingly the reverse direction.

To assemble the sprayer head:**To assemble the sprayer head to the handle [Fig. A4]:**

1. Push the sprayer head ⑨ all the way into the sprayer handle ⑪. Make sure that the O-Ring ⑩ is in the right position.
2. Screw the sprayer head ⑨ onto the sprayer handle ⑪ by hand (do not use pliers).

To assemble the sprayer handle to the hose [Fig. A5]:

3. Push the union nut ⑫ onto the hose ⑬.
4. Push the filter ⑭ into the sprayer handle ⑪.
5. Push the hose ⑬ onto the filter ⑭.
6. Screw the hose ⑬ onto the sprayer handle ⑪ by hand using the union nut ⑫ (do not use pliers).

To assemble the hose to the pump [Fig. A6]:

7. Push the union nut ⑫ onto the hose ⑬.
8. Push the connector ⑮ into the pump ⑯.
9. Push the hose ⑬ onto the connector ⑮.
10. Screw the hose ⑬ onto the pump ⑯ by hand using the union nut ⑫ (do not use pliers).

3. OPERATION

To fill the tank [Fig. O1]:

1. Stir the spray liquid thoroughly.
2. Unscrew the tank cap ⑰.
3. Fill the spray liquid up to the highest mark (12 litres). Please observe the safety and proportioning instructions provided by the manufacturer of the spray liquid you are going to spray.
4. Screw the tank cap ⑰ tight again by hand (do not use pliers).

To spray the liquid [Fig. O2/A1]:

1. Strap the Backpack Sprayer to your back.
2. Adjust the length of the carrying straps ① as required using the strap adjusters ⑦. (The stitched end of the carrying strap is threaded through the strap adjusters ⑦ at the factory.)
3. Push down the pump lever ④ repeatedly (approx. 7 – 9 times) until it becomes more difficult to press the lever and you feel resistance.
4. Push the button H on the sprayer handle.
The Backpack Sprayer starts spraying.
5. Release the button H on the sprayer handle.
The Backpack Sprayer stops spraying.

To adjust the spray lance [Fig. O3]:

1. Loosen the union nut ⑮.
2. Pull out the spray lance ⑳ to the desired length.
3. Tighten the union nut ⑮ again.

To adjust the spray jet [Fig. O4]:

You can adjust the spray jet from full jet (nozzle open) to a fine mist (nozzle closed).

→ Open or close the nozzle ㉑ to adjust the spray jet as required.

4. MAINTENANCE

To clean the Backpack Sprayer [Fig. A5/M1]:

The Backpack Sprayer must be cleaned after each use.

1. Push the button ⑮ on the sprayer handle and release the pressure through the spray lance.
2. Unscrew the tank cap ⑰. If the outside of the cap is dirty, thoroughly clean the area around the thread and thread O-ring ㉒.
3. Clean the inlet filter ㉓ and the tank cap ⑰ in clean water.
4. Empty the tank and fill it with clean water (with detergent added to the water if necessary).
5. Spray the water out of the Backpack Sprayer until the tank is empty.
This cleans the nozzle and the valves.
6. Leave the Backpack Sprayer open and allow it to dry.

Do not dispose of residual products by pouring them into the sewerage system. Please contact your local disposal centre and ask about proper disposal of the spray liquid you have used.

5. STORAGE

To put into storage:

1. Clean the backpack (see 4. MAINTENANCE).
2. Loosen the tank cap and store the Backpack Sprayer in a frost-free place.

6. TROUBLESHOOTING

To clean the filter [Fig. A5]:

1. Unscrew the union nut ⑫ and pull the hose ⑬ with filter ⑭ out of the sprayer handle ⑪.
2. Clean the filter ⑭ under running water.
3. Reassemble the sprayer handle (see 3. ASSEMBLY
To assemble the sprayer handle to the hose).

To clean the pump [Fig. T1]:

If the pump does not provide pressure after cleaning your Backpack Sprayer you must also clean the pump.

1. Push out the locking ring ㉔ (e.g. with a screwdriver).
2. Pull the joint rod ㉕ out of the pump ⑯.
3. Unscrew the union ring ㉖ and pull out the pump ⑯.
4. Check the pump O-ring ㉗ and replace it if necessary.
5. Pull out the inner part of the pump ㉘ and the gasket ㉙.
6. Clean all pump parts and gaskets with water (and detergent).
7. Reassemble the pump in the reverse order. Make sure that the pump gaskets are seated properly after installation and are not squashed.

Problem	Possible Cause	Remedy
Pump does not provide pressure	Valve in the tank cap is blocked.	→ Clean the tank cap..
	Hose connection at the pump and the sprayer handle are leaking.	→ Tighten the hose connections at the pump and the sprayer handle.
	Pump O-ring (27) is leaking at the pump.	→ Clean the pump. Check the pump O-ring (27) and replace it if necessary.
Backpack Sprayer does not spray although there is sufficient pressure or sprays with a poor spray jet	Nozzle is blocked.	→ Clean the nozzle.
	Filter (14) is clogged.	→ Clean the filter (14) in the sprayer handle.
Tank is difficult to open	Pressure in the tank is too low because the valve in the tank cap (17) is blocked.	→ Clean the tank cap (17).

NOTE: For any other malfunctions please contact the GARDENA service department. Repairs must only be done by GARDENA service departments or specialist dealers approved by GARDENA.

7. TECHNICAL DATA

Max. capacity	12 l
Minimum / maximum spray lance length	60 / 100 cm
Hose length	125 cm
Permissible working pressure	3 bar
Permissible operating temperature	35 °C

8. SERVICE/WARRANTY

Service:

Please contact the address on the back page.

Warranty statement:

In the event of a warranty claim, no charge is levied to you for the services provided.

GARDENA Manufacturing GmbH grants a warranty for all original GARDENA new products for two years from the date of original purchase from the retailer, provided that the devices have been for private use only. This manufacturer's warranty does not apply to products acquired second hand. This warranty includes all significant defects of the product that can be proved to be material or manufacturing faults. This warranty is fulfilled by supplying a fully functional replacement product or by repairing the faulty product sent to us free of charge; we reserve the right to choose between these options. This service is subject to the following provisions:

- The product has been used for its intended purpose as per the recommendations in the operating instructions.
- Neither the purchaser nor a third party has attempted to open or repair the product.
- Only Original GARDENA replacement parts and wear parts have been used for operation.
- Presentation of the receipt.

Normal wear and tear of parts and components (such as blades, blade fixing parts, turbines, light bulbs, V-belts/toothed belts, impellers, air filters, spark plugs), visual changes, wear parts and consumables are excluded from the warranty.

This manufacturer's warranty is limited to replacement and repair of products in accordance with the abovementioned conditions. The manufacturer's warranty does not constitute an entitlement to lodge other claims against us as a manufacturer, such as for damages. This manufacturer's warranty does not, of course, affect statutory and contractual warranty claims against the dealer/retailer.

The manufacturer's warranty is governed by the law of the Federal Republic of Germany.

In case of a warranty claim, please return the faulty product, together with a copy of the receipt and a description of the fault, with postage paid to the service address.

<p>DE Produkthaftung Wir weisen ausdrücklich darauf hin, dass wir in Übereinstimmung mit dem Produkthaftungsgesetz nicht für Schäden haften, die durch unsere Produkte entstehen, wenn diese unsachgemäß und nicht durch einen von uns autorisierten Servicepartner repariert wurden oder wenn keine Original GARDENA Teile oder von uns zugelassene Teile verwendet wurden.</p>
<p>EN Product liability In accordance with the German Product Liability Act, we hereby expressly declare that we accept no liability for damage incurred from our products where said products have not been properly repaired by a GARDENA-approved service partner or where original GARDENA parts or parts authorised by GARDENA were not used.</p>
<p>FR Responsabilité Conformément à la loi relative à la responsabilité du fait des produits défectueux, nous déclarons expressément par la présente que nous déclinons toute responsabilité pour les dommages résultant de nos produits, si lesdits produits n'ont pas été correctement réparés par un partenaire d'entretien agréé GARDENA ou si des pièces d'origine GARDENA ou des pièces agréées GARDENA n'ont pas été utilisées.</p>
<p>NL Productaansprakelijkheid Conform de Duitse wet inzake productaansprakelijkheid verklaren wij hierbij uitdrukkelijk dat wij geen aansprakelijkheid aanvaarden voor schade ontstaan uit onze producten waarbij deze producten niet zijn gerepareerd door een GARDENA-erkende servicepartner of waarbij geen originele GARDENA-onderdelen of onderdelen die door GARDENA zijn goedgekeurd zijn gebruikt.</p>
<p>SV Produktansvar I enlighet med tyska produktansvarslagar förklarar vi härmed uttryckligen att vi inte åtar oss något ansvar för skador som orsakas av våra produkter där produkterna inte har genomgått korrekt reparation från en GARDENA-godkänd servicepartner eller där originaldelar från GARDENA eller delar godkända av GARDENA inte använts.</p>
<p>DA Produktsvar I overensstemmelse med den tyske produktansvarslav erklærer vi hermed udtrykkeligt, at vi ikke påtager os noget ansvar for skader på vores produkter, hvis de pågældende produkter ikke er blevet repareret korrekt af en GARDENA-godkendt servicepartner, eller hvor der ikke er brugt originale GARDENA-reservedele eller godkendte reservedele fra GARDENA.</p>
<p>FI Tuotevastuu Saksan tuotevastuulain mukaisesti emme ole vastuussa laitteiden vaurioista, jos korjauksia ei ole tehnyt GARDENAn hyväksymä huoltoliike tai jos niiden syynä on muiden kuin alkuperäisten GARDENA-varaosien tai GARDENAn hyväksymien varaosien käyttö.</p>
<p>IT Responsabilità del prodotto In conformità con la Legge tedesca sulla responsabilità del prodotto, con la presente dichiariamo espressamente che decliniamo qualsiasi responsabilità per danni causati dai nostri prodotti qualora non siano stati correttamente riparati presso un partner di assistenza approvato GARDENA o laddove non siano stati utilizzati ricambi originali o autorizzati GARDENA.</p>
<p>ES Responsabilidad sobre el producto De acuerdo con la Ley de responsabilidad sobre productos alemana, por la presente declaramos expresamente que no aceptamos ningún tipo de responsabilidad por los daños ocasionados por nuestros productos si dichos productos no han sido reparados por un socio de mantenimiento aprobado por GARDENA o si no se han utilizado piezas originales GARDENA o piezas autorizadas por GARDENA.</p>
<p>PT Responsabilidade pelo produto De acordo com a lei alemã de responsabilidade pelo produto, declaramos que não nos responsabilizamos por danos causados pelos nossos produtos, caso os tais produtos não tenham sido devidamente reparados por um parceiro de assistência GARDENA aprovado ou se não tiverem sido utilizadas peças GARDENA originais ou peças autorizadas pela GARDENA.</p>
<p>PL Odpowiedzialność za produkt Zgodnie z niemiecką ustawą o odpowiedzialności za produkt, niniejszym wyraźnie oświadczamy, że nie ponosimy żadnej odpowiedzialności za szkody poniesione na skutek użytkowania naszych produktów, w przypadku gdy naprawa tych produktów nie była odpowiedzialnie przeprowadzana przez zatwierdzonego przez firmę GARDENA partnera serwisowego lub nie stosowano oryginalnych części GARDENA albo części autoryzowanych przez tę firmę.</p>
<p>HU Termékszavatosság A németországi termékszavatossági törvénnyel összhangban ezennel nyomatékosan kijelentjük, hogy nem vállalunk felelősséget a termékeinkben keletkezett olyan károkért, amelyek valamely GARDENA által jóváhagyott szervizpartner által nem megfelelően végzett javításból adódtak, vagy amely során nem eredeti GARDENA alkatrészeket vagy a GARDENA által jóváhagyott alkatrészeket használtak fel.</p>
<p>CS Odpovědnost za výrobek V souladu s německým zákonem o odpovědnosti za výrobek tímto výslovně prohlašujeme, že nepřijímáme žádnou odpovědnost za poškození vzniklá na našich výrobcích, kdy zmíněné výrobky nebyly řádně opraveny schváleným servisním partnerem GARDENA nebo kdy nebyly použity originální náhradní díly GARDENA nebo náhradní díly autorizované společností GARDENA.</p>
<p>SK Zodpovednosť za produkt V súlade s nemeckými právnymi predpismi upravujúcimi zodpovednosť za výrobok týmto výslovné prehlasujeme, že nenesieme žiadnu zodpovednosť za škody spôsobené našimi výrobkami, v prípade ktorých neboli náležité opravy vykonané servisným partnerom schváleným spoločnosťou GARDENA alebo neboli použité diely spoločnosti GARDENA alebo diely schválené spoločnosťou GARDENA.</p>
<p>EL Ευθύνη προϊόντος Σύμφωνα με τον γερμανικό νόμο περί Ευθύνης για τα Προϊόντα, με το παρόν δηλώνουμε ρητώς ότι δεν αποδεχόμαστε καμία ευθύνη για τυχόν ζημιές που προκύπτουν από τα προϊόντα μας εάν αυτά δεν έχουν επισκευαστεί σωστά από κάποιον εγκεκριμένο συνεργάτη επισκευών της GARDENA ή εάν δεν έχουν χρησιμοποιηθεί αυθεντικά εξαρτήματα GARDENA ή εξαρτήματα εγκεκριμένα από την GARDENA.</p>
<p>SL Odgovornost proizvajalca V skladu z nemškimi zakoni o odgovornosti za izdelke, izrecno izjavljajo, da ne sprejemamo nobene odgovornosti za škodo, ki jo povzročijo naši izdelki, če teh niso ustrezno popravili GARDENINI odobreni servisni partnerji ali pri tem niso bili uporabljeni originalni GARDENINI nadomestni deli ali GARDENINIMI homologiranimi nadomestnimi deli.</p>
<p>HR Pouzdanost proizvoda Sukladno njemačkom zakonu o pouzdanosti proizvoda, ovime izričito izjavljujemo kako ne prihvaćamo nikakvu odgovornost za oštećenja na našim proizvodima nastala uslijed neispravnog popravka od strane servisnog partnera kojeg odobrava GARDENA ili uslijed nekorištenja originalnih GARDENA dijelova ili dijelova koje odobrava GARDENA.</p>
<p>RO Răspunderea pentru produs În conformitate cu Legea germană privind răspunderea pentru produs, declarăm în mod expres prin prezentul document că nu acceptăm nicio răspundere pentru defecțiunile suferite de produsele noastre atunci când acestea nu au fost reparate în mod corect de un atelier de service partener, aprobat de GARDENA, sau când nu au fost utilizate piese GARDENA originale sau piese autorizate de GARDENA.</p>
<p>BG Отговорност за вреди, причинени от стоки Съгласно германския Закон за отговорността за вреди, причинени от стоки, с настоящото изрично декларираме, че не носим отговорност за щети, причинени от нашите продукти, ако те не са били правилно ремонтирани от одобрен от GARDENA сервиз или ако не са използвани оригинални части на GARDENA или части, одобрени от GARDENA.</p>
<p>ET Tootevastutus Vastavalt Saksamaa tootevastutusseadusele deklareerime käesolevaga selgesõnaliselt, et me ei kannu mingisugust vastutust meie toodetest tingitud kahjude eest, kui need tooted ei ole korrektselt parandatud GARDENA heakskiidetud hoolduspartneri poolt või kui parandamisel ei ole kasutatud GARDENA originaalosi või GARDENA volitatud osi.</p>
<p>LT Gaminio patikimumas Mes aiškiai pareiškiame, kad, atsižvelgiant į Vokietijos gaminių patikimumo įstatymą, nepriisiame atsakomybės dėl bet kokios žalos, patirtos dėl mūsų gaminių, jeigu jie buvo netinkamai taisomi arba juo dalys buvo pakeistos neoriginaliomis GARDENA dalimis ar nepatvirtintomis dalimis, arba jeigu remonto darbai buvo atliekami ne GARDENA techninės priežiūros centro specialistų.</p>
<p>LV Atbildība par produkcijas kvalitāti Saskaņā ar Vācijas likumu par atbildību par produkcijas kvalitāti ar šo mēs paziņojam, ka neuzņemamies atbildību par bojājumiem, kas radušies, lietojot mūsu izstrādājumus, kuru remontu nav veicis uzņēmuma GARDENA apstiprināts apkopes partneris vai kuru remontam netika izmantotas oriģinālās GARDENA detaļas vai detaļas, kuru lietošanu apstiprinājis uzņēmums GARDENA.</p>

Deutschland / Germany

GARDENA
Manufacturing GmbH
Central Service
Hans-Lorenser-Straße 40
D-89079 Ulm
Produktfragen:
(+49) 731 490-123
Reparaturen:
(+49) 731 490-290
service@gardena.com
http://www.gardena.com

Albania

KRAFT SHPK
Autostrada Tirane-Durres
Km 7
1051 Tirane

Argentina

ROBERTO C. RUMBO S.R.L.
Predio Norlog
Lote 7
Benavidez. ZC:1621
Buenos Aires
ventas@rumbosrl.com.ar

Australia

Husqvarna Australia Pty. Ltd.
Locked Bag 5
Central Coast BC
NSW 2252
Phone: (+61) (0) 2 4352 7400
customer.service@
husqvarna.com.au

Austria / Österreich

Husqvarna Austria GmbH
Industriezeile 36
4010 Linz
Tel.: (+43) 732 77 01 01-485
service.gardena@
husqvarnagroup.com

Azerbaijan

Firm Progress
a. Aliyev Str. 26A
1052 Baku

Belarus

Private Enterprise
"Master Garden"
Minsk
Sharangovich str., 7a
Phone: (+375) 17 257-00-33
Mob.: (+375) 29 676-16-09
mg@mastergarden.by

Belgium

Husqvarna Belgium nv
Gardena Division
Leuvensesteenweg 542
Planet II E
1930 Zaventem
België

Bosnia / Herzegovina

SILK TRADE d.o.o.
Industrijska zona Bukva bb
74260 Tešanj

Brazil

Husqvarna do Brasil Ltda
Av. Francisco Matarazzo,
1400 - 19º andar
São Paulo - SP
CEP: 05001-903
Tel: 0800-112252
marketing.br.husqvarna@
husqvarna.com.br

Bulgaria

AGROLAND Бълг рия АД
бул. 8 Декември, №13
Офис 5
1700 Студентски гр д
София
Тел.: (+359) 2466 69 10
info@agroland.eu

Canada / USA

GARDENA Canada Ltd.
100 Summerlea Road
Brampton, Ontario L6T 4X3
Phone: (+1) 905 792 93 30
info@gardenacanada.com

Chile

REPRESENTACIONES
JCE S.A.
Av. Del Valle Norte 857,
Piso 4
Santiago RM
Phone: (+56) 2 24142560
contacto@jce.cl

China

Husqvarna (Shanghai)
Management Co., Ltd.
富世华 (上海) 管理有限公司
3F, Benq Square B,
No207, Song Hong Rd.,
Chang Ning District,
Shanghai
PRC. 200335
上海市长宁区淞虹路207号明
基广场B座3楼, 邮编: 200335

Colombia

Husqvarna Colombia S.A.
Calle 18 No. 68 D-31, zona
Industrial de Montevideo
Bogotá, Cundinamarca
Tel. 571 2922700 ext. 105
jairo.salazar@
husqvarna.com.co

Costa Rica

Compania Exim
Euroiberoamericana S.A.
Los Colegios, Moravia,
200 metros al Sur del Colegio
Saint Francis - San José
Phone: (+506) 297 68 83
exim_euro@racsa.co.cr

Croatia

Husqvarna Austria GmbH
Industriezeile 36
4010 Linz
Tel.: (+43) 732 77 01 01-485
service.gardena@
husqvarnagroup.com

Cyprus

Med Marketing
17 Digeni Akrita Ave
P.O. Box 27017
1641 Nicosia

Czech Republic

Husqvarna Česko s.r.o.
Türkova 2319/5b
149 00 Praha 4 - Chodov
Bezplatná infolinka:
800 100 425
servis@cz.husqvarna.com

Denmark

GARDENA DANMARK
Lejrvvej 19, st.
3500 Værløse
Tlf.: (+45) 7026 4770
husqvarna@husqvarna.dk
www.gardena.com/dk

Dominican Republic

BOSQUESA, S.R.L
Carretera Santiago Licey
Km. 5 ½
Esquina Copal II.
Santiago
Dominican Republic
Phone: (+809) 736-0333
joserbosquesa@claro.net.do

Ecuador

Husqvarna Ecuador S.A.
Arupos E1-181 y 10 de
Agosto Quito, Pichincha
Tel. (+593) 22800739
francisco.jacome@
husqvarna.com.ec

Estonia

Husqvarna Eesti OÜ
Valdeku 132
EE-11216 Tallinn
info@agardena.ee

Finland

Oy Husqvarna Ab
Gardena Division
Lautatarhankatu 8 B/PL 3
00581 HELSINKI
www.gardena.fi

France

Husqvarna France
9/11 Allée des pierres mayettes
92635 Gennevilliers Cedex
France
http://www.gardena.com/fr
N° AZUR: 0 810 00 78 23
(Prix d'un appel local)

Georgia

Transporter LLC
113b Belialshvili street
0159 Tbilisi, Georgia

Great Britain

Husqvarna UK Ltd
Preston Road
Aycliffe Industrial Park
Newton Aycliffe
County Durham
DL5 6UP
info.gardena@
husqvarna.co.uk

Greece

Π. ΠΑΠΑΔΟΠΟΥΛΟΣ ΑΕΒΕ
Λεωφ. Αθηνών 92
Αθήνα
T.K.104 42
Ελλάδα
Τηλ. (+30) 210 51 93 100
info@papadopoulos.com.gr

Hungary

Husqvarna Magyarország Kft.
Ezred u. 1-3
1044 Budapest
Telefon: (+36) 1 251-4161
vevoszolgalat.husqvarna@
husqvarna.hu

Iceland

BYKO ehf.
Bildshöfoa 20
110 Reykjavik

Ireland

Husqvarna UK Ltd
Preston Road
Aycliffe Industrial Park
Newton Aycliffe
County Durham
DL5 6UP
info.gardena@
husqvarna.co.uk

Italy

Husqvarna Italia S.p.A.
Via Santa Vecchia 15
23868 VALMADRERA (LC)
Phone: (+39) 0341.203.111
assistenza.italia@
it.husqvarna.com

Japan

Husqvarna Zenoah Co., Ltd.
1-9 Minamidai
Kawagoe
350-1165 Saitama
gardena-jp@
husqvarnagroup.com

Kazakhstan

LAMED Ltd.
155/1, Tazhibayevoy Str.
050060 Almaty
IP Schmidt
Abayavenue 3B
110 005 Kostanay

Korea

Kyung Jin Trading CO.,LTD.
107-4, SunDuk Bld.,
YangJae-dong,
Seocho-gu,
Seoul, (zipcode: 137-891)
Phone: (+82) (0)2 574-6300

Latvia

Husqvarna Latvija SIA
Ulbrokas 19A
LV-1021 Riga
info@gardena.lv

Lithuania

UAB Husqvarna Lietuva
Ateities pl. 77C
LT-52104 Kaunas
info@gardena.lt

Luxembourg

Magasins Jules Neuberg
39, rue Jacques Stas
Luxembourg-Gasperich 2549
Case Postale No. 12
Luxembourg 2010
Phone: (+352) 40 14 01
api@neuberg.lu

Mexico

AFOSA
Av. Lopez Mateos Sur # 5019
Col. La Calma 45070
Zapopan, Jalisco
Mexico
Phone: (+52) 33 3818-3434
icornejo@afosa.com.mx

Moldova

Convel S.R.L.
290A Muncesti Str.
2002 Chisinau

Netherlands

Husqvarna Nederland B.V.
GARDENA Division
Postbus 50131
1305 AC ALMERE
Phone: (+31) 36 521 00 10
info@gardena.nl

Neth. Antilles

Jonka Enterprises N.V.
Sta. Rosa Weg 196
P.O. Box 8200
Curaçao
Phone: (+599) 9 767 66 55
pgm@jonka.com

New Zealand

Husqvarna New Zealand Ltd.
PO Box 76-437
Manukau City 2241
Phone: (+64) (0) 9 9202410
support.nz@husqvarna.co.nz

Norway

Husqvarna Norge AS
Gardena Division
Trøskenveien 36
1708 Sarpsborg
info@gardena.no

Peru

Husqvarna Perú S.A.
Jr. Ramón Cárcamo 710
Lima 1
Tel: (+51) 1 3320 400 ext. 416
juan.remuzgo@
husqvarna.com

Poland

Husqvarna
Poland Spółka z o.o.
ul. Wysockiego 15 b
03-371 Warszawa
Phone: (+48) 22 330 96 00
gardena@husqvarna.com.pl

Portugal

Husqvarna Portugal, SA
Lagoa - Albarraque
2635 - 595 Rio de Mouro
Tel.: (+351) 21 922 85 30
Fax : (+351) 21 922 85 36
info@gardena.pt

Romania

Madex International Srl
Soseaua Odaii 117-123,
RO 013603 București, S1
Phone: (+40) 21 352.76.03
madex@ines.ro

Russia / Россия

ООО „Хускв рн “
141400, Московск я обл.,
г. Химки,
улиц Ленингр дск я,
вл дение 39, стр.6
Бизнес Центр
„Химки Бизнес П рк“,
помещение ОВ02_04
http://www.gardena.ru

Serbia

Domel d.o.o.
Autoput za Novi Sad bb
11273 Belgrade
Phone: (+381) 1 18 48 88 12
miroslav.jejina@domel.rs

Singapore

Hy-Ray PRIVATE LIMITED
40 Jalan Pemimpin
#02-08 Tat Ann Building
Singapore 577185
Phone: (+65) 6253 2277
shiyang@hyray.com.sg

Slovak Republic

Husqvarna Česko s.r.o.
Türkova 2319/5b
149 00 Praha 4 - Chodov
Bezplatná infolinka: 800 154 044
servis@sk.husqvarna.com

Slovenia

Husqvarna Austria GmbH
Industriezeile 36
4010 Linz
Tel.: (+43) 732 77 01 01-485
service.gardena@
husqvarnagroup.com

South Africa

Husqvarna South Africa (Pty) Ltd
Postnet Suite 250
Private Bag X6,
Cascades, 3202, South Africa
Phone: (+27) 33 846 9700
info@gardena.co.za

Spain

Husqvarna España S.A.
Calle de Rivas nº 10
28052 Madrid
Phone: (+34) 91 708 05 00
atencioncliente@gardena.es

Suriname

Deto Handelmaatschappij N.V.
Kernkampweg 72-74
P.O.Box: 12782
Paramaribo - Suriname
South America
Phone: (+597) 438050
www.deto.sr

Sweden

Husqvarna AB/
GARDENA Sverige
Drottninggatan 2
561 82 Huskvarna Sverige

Switzerland / Schweiz

Husqvarna Schweiz AG
Consumer Products
Industriestrasse 10
5506 Mägenwil
Phone: (+41) (0) 62 887 37 90
info@gardena.ch

Turkey

Dost Bahçe Diş Ticaret
Mümessillik A.Ş
Yunus Mah. Adil Sok. No:3
Ic Kapi No: 1 Kartal
34873 Istanbul
Phone: (+90) 216 38 93 939
info@dostbahce.com.tr

Ukraine / Україна

ТОВ «Хускв рн Укр ін »
вул. В сільківськ , 34,
офіс 204-г
03022, м. Київ
Тел. (+38) 0 800 504 804
info@gardena.ua

Uruguay

FELI SA
Entre Ríos 1083 CP 11800
Montevideo - Uruguay
Tel: (+598) 22 03 18 44
info@felisa.com.uy

Venezuela

Corporación Casa y Jardín C.A.
Av. Caroní, Edif. Trezmen, PB.
Colinas de Bello Monte.
1050 Caracas.
Tlf: (+58) 212 992 33 22
info@casayjardin.net.ve

11140-20.960.01/1020
© GARDENA Manufacturing GmbH
D-89079 Ulm
http://www.gardena.com