

This Owner's Manual is provided and hosted by [Appliance Factory Parts](http://ApplianceFactoryParts.com).



GENERAL 1099LHS Owner's Manual

[Shop genuine replacement parts for GENERAL
1099LHS](#)



[Find Your GENERAL Humidifier Parts - Select From 70 Models](#)

----- Manual continues below -----

Model 1099LHS

Installation & Owners Manual

Humidifier
GFI #5015

Read and Save These Instructions

- Installation by anyone other than a qualified contractor voids the warranty.
- Product designed for residential installation only. Commercial installation voids warranty.
- Modification or alteration of product, parts, installation instructions or local safety codes voids warranty.
 - Read our full warranty policy at the end of this document.



Manufacturers of Whole House Residential Indoor Air Quality Products.

www.generalfilters.com

BREATHE HEALTHIER™
GeneralAire®

By General Filters, Inc.

1099LHS Table of Contents

Subject	Page #
Specifications	3
Unit Location	3
Additional Materials That May Be Necessary	3
Installation	4
Saddle Valve Installation	5
Installing / Wiring the Control	6
How the Humidifier Works	7
Maintenance	7
Parts Drawing	8
Humidifier Chassis Duct Cut Out	8
Trouble Shooting	9
FAQ's	10
Warranty Registration	11
Limited Warranty	11-12

**WARNING!**

This symbol indicates: **IMPORTANT INSTRUCTIONS!**

Failure to heed them can result in serious injury or death.

**CAUTION!**

This symbol indicates: **IMPORTANT INSTRUCTIONS!**

Failure to heed them can result in serious injury or material property damage.

Specifications

- **Model:** 1099LHS Legacy Flow Through Humidifier (GFI #5015)
- **Type:** Flow Through
- **GPD:** 19 Based on 120° F Plenum Temperature
- **Warranty:** 5 Years
- **Replacement Vapor Pad®:** 1099-20 (GFI#7047)
(Replace 1-2 times per season)
- **Dimensions:** 16" W x 16" H x 12-1/4" D
- **Weight:** 15 Lbs.
- **Home Size:** To 3,000 Sq. Ft.
- **Installation:** Warm Air Plenum / Right or Left
- **Plenum Opening:** 14-1/8" W X 12" H
- **Bypass Duct:** 7"
- **Pallet Qty:** 16
- **Cabinet Construction:** UV-Stable Automotive Grade Plastic
- **Humidistat:** Models: MHX3C (Included)
- **Voltage:** 24V
- **In The Box:** Humidifier, humidistat, installation instructions, Vapor Pad®, parts kit, saddle valve, 7" connecting collar, 24V transformer

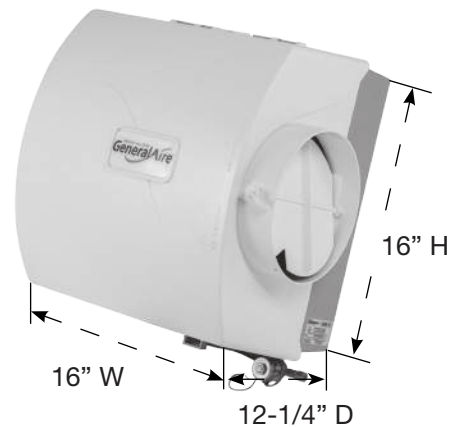

Unit Location

WARNING: Disconnect electrical power before beginning installation.

- Do not install where temperatures fall below 32° F or where plenum temperatures exceed 200° F. For maximum evaporative capacity, install this humidifier on the warm air supply plenum.
- **INSTALLATION:** For installation on a vertical surface of the warm air plenum of any forced air furnace.

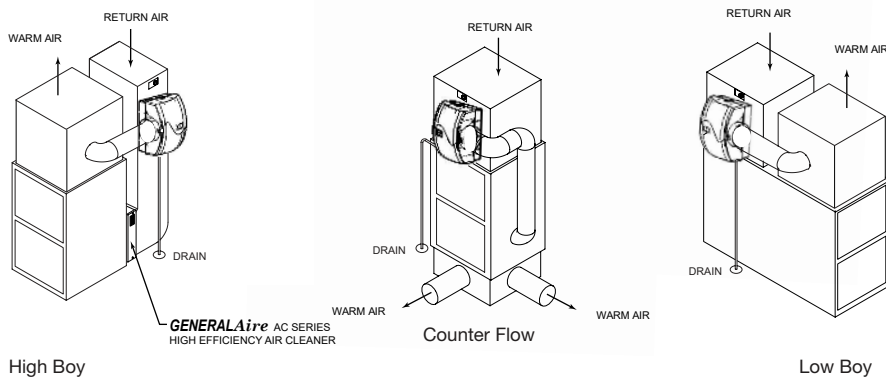

Additional Materials That May Be Necessary

1. 1/4" Diameter plastic supply tubing for cold water applications, or 1/4" copper supply tubing for hot water applications
2. 7" Diameter galvanized by-pass pipe
3. Electrical wire and wire nuts
4. Current sensing relay Model #GA50 (GFI #7026) suggested

BREATHE HEALTHIER
GeneralAire®

www.generalfilters.com

Installation

1. Select location on vertical surface of warm or return air plenum for mounting humidifier. Tape mounting template in place making sure the template is level. Do not install humidifier or 7" bypass pipe where the blanked off ends of a cooling coil will restrict air flow to the humidifier. Extend horizontal centerline from template to the adjacent plenum. Scribe 7" circle 10" to 15" from side of humidifier, on cabinet centerline, using connecting collar as guide.

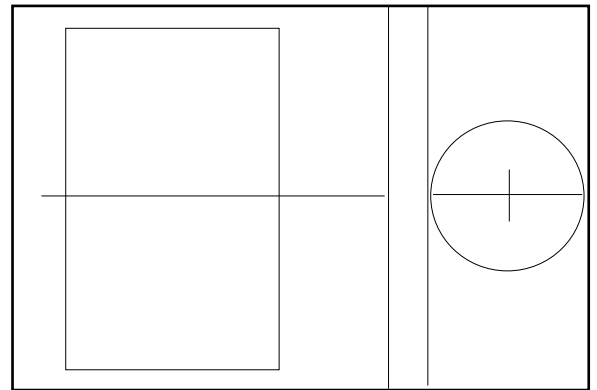

2. Cut out center section of template and 7" hole. Humidifier is self retaining. Slide top side in first, then slide chassis down. Level chassis and install two center screws. If bypass pipe installs to opposite side of chassis, bend clip on side discharge, remove side discharge, and reinstall discharge to opposite side of chassis. Install remaining six screws. Insert Vapor Pad® assembly, with black patch of Vapor Pad® on top.

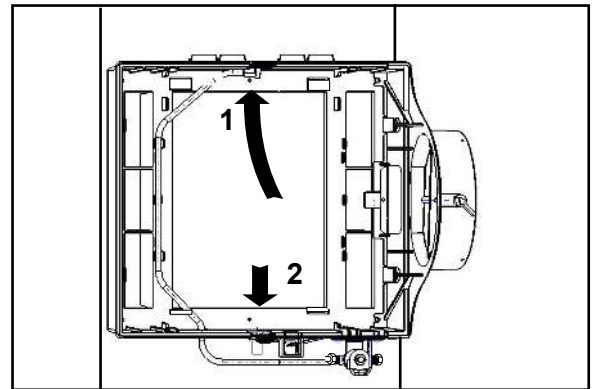

3. Connect by-pass pipe to collar and humidifier cabinet. Using holes at top and bottom of side panel discharge, pierce 2 self tapping screws through the bypass pipe.

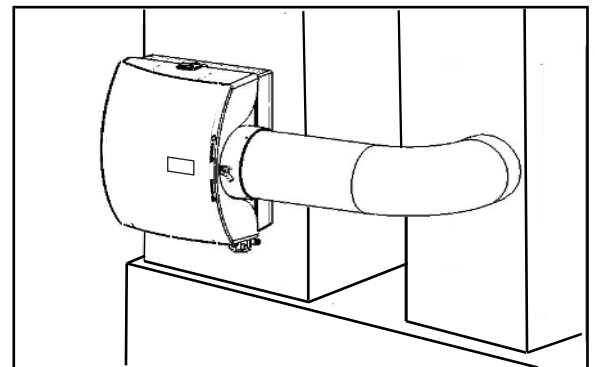

Saddle Valve Installation



CAUTION: Turn off water supply.



CAUTION: Do not use plastic tubing on hot water or in contact with any hot plenum surface or duct. Installation of this saddle valve must meet or exceed local codes and ordinances.

4. Mount the Self-Tapping Saddle Valve.

Copper Pipe:

1. Retract piercing pin into valve body by turning handle counterclockwise.
2. Screw valve body into upper bracket and tighten.
3. Place rubber gasket over piercing pin.
4. Assemble saddle valve over copper pipe using enclosed screws, nuts and lower bracket.
5. Tighten screws evenly and firmly. Brackets should be parallel.
6. Complete compression connection to saddle valve outlet.
7. Turn handle clockwise to pierce tubing and close saddle valve.
8. Turn handle counterclockwise to open saddle valve, leave open for several seconds to flush dirt from pipe and tubing.

Steel, Brass or Hard Plastic Pipe:

1. Shut off water supply and drain pipe.
2. Turn handle clockwise to expose piercing pin and close saddle valve.
3. Place rubber gasket over piercing pin.
4. Drill 1/8" hole in pipe using a hand crank drill to avoid shock hazard.
5. Assemble saddle valve over steel, brass or hard plastic pipe using enclosed screws, nuts and lower bracket.
6. Tighten screws evenly and firmly. Brackets should be parallel.
7. Complete compression connection to saddle valve outlet.
8. Turn handle counterclockwise to open saddle valve, leave open for several seconds to flush dirt from pipe and tubing.

Threaded Pipe Fittings:

1. Turn handle clockwise to expose piercing pin and close saddle valve.
2. Seal valve body threads using pipe tape or sealant.
3. Install valve into 1/8" NPT fitting.
4. Complete compression connection to saddle valve outlet.
5. Turn handle counterclockwise to open saddle valve, leave open for several seconds to flush dirt from pipe and tubing.

5. Install the copper or plastic tubing.

Connect 1/4" O.D. tubing to the saddle valve. Copper tubing requires a brass compression nut and brass sleeve. Plastic tubing requires a brass insert inside the tubing, a plastic sleeve on the outside with a brass compression nut. See figure to right.

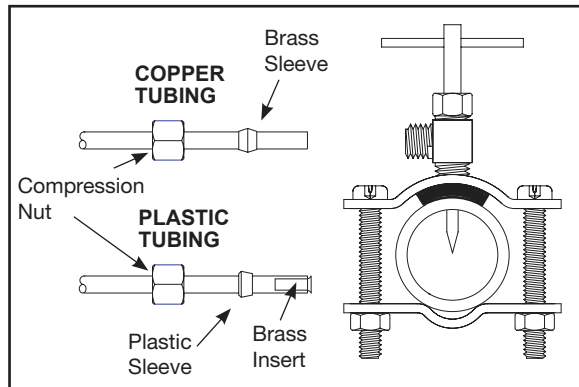

6. Connect 1/4" water supply tube to brass filter at inlet of solenoid.



CAUTION: Do not use plastic tubing in contact with any hot plenum surface or duct. If using plastic tubing, use tube insert P189 (GFI #7567) and plastic compression sleeve P190 (GFI #7568) (available as part of assembly 747-38 tubing kit (GFI #7078).

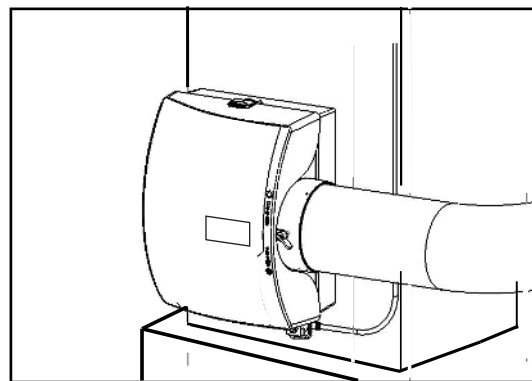

Installing / Wiring the Control

WARNING: ALL WIRING SHOULD COMPLY WITH LOCAL ELECTRICAL CODES.

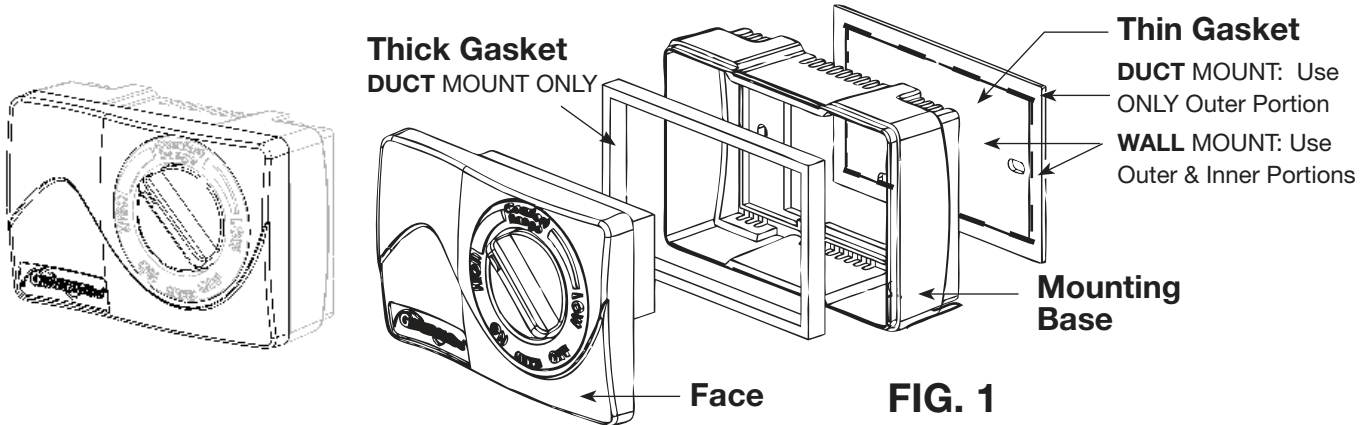

6. MHX3C: DUCT Mounting (Return Air Duct)

CAUTION: Do not install the humidistat on the warm air duct.

1. Locate the humidistat at least 24" upstream of the humidifier or bypass on the return air duct. Avoid areas of direct radiation like secondary heat exchangers in the fan compartment.
2. Place template using level. Cut sensor hole as shown on template. Drill four 3/32" holes (not shown).
3. Remove the housing from the base by prying with a small screwdriver at the notch in the side of the housing.
4. Gaskets: Place the outer portion ONLY of the thin foam gasket on the humidistat base and mount the base with four screws. Place the thick gasket inside the wall mount base to seal off air entering through the vents. Low voltage wire may enter the humidistat under the foam seal.
5. Connect wires to screw terminals on the control assembly as shown in wiring diagram. Replace housing.

6. MHX3C: WALL Mounting Instructions

1. Choose a location for the humidistat about five feet above the floor on an inside wall with average room temperature and humidity conditions.
2. Drill a small hole in the wall and run low voltage wiring to the location chosen. Pull about 6" of wire through the hole. Plug the opening to prevent drafts from affecting the humidistat operation. Remove the housing from the base by prying with a small screwdriver at the notch in the side of the housing.
3. Gaskets: Place the entire outer and inner portions of the gasket on the base as shown. Do NOT install the thick gasket inside the base.
4. Mount the base horizontally over the wires using level. Attach directly to the wall, using four screws provided.
5. Connect wires to screw terminals on the control assembly as shown in wiring diagram. Replace housing.

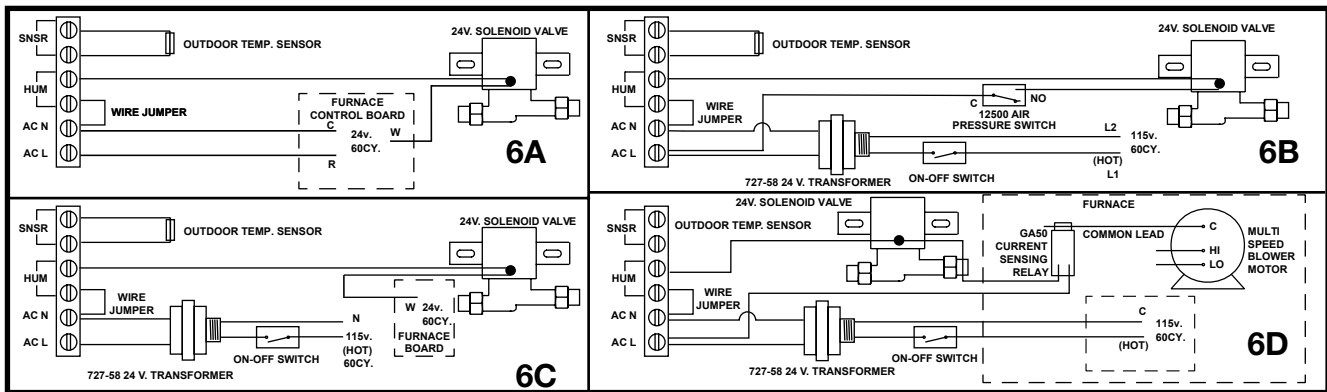

7. Connect drain hose to 1/2" spout on humidifier cabinet using hose clamp if necessary. Run 1/2" hose to suitable drain such as floor drain, sewer or laundry sink.

CAUTION: Be sure hose has continuous slope and is not kinked at any point.

8. Turn on water supply and check operation of humidifier. Set humidistat to a demand setting. With the furnace off, the solenoid valve should be closed. Start the furnace, the solenoid valve should open when the blower or burner circuit is energized. Check flow of water through distributor trough and evaporator pad. The standard Orange orifice GA4299 (GFI #7581) will supply approximately 4.75 GPH of water at a line water pressure of 60 psi. For low water pressures (20-40 psi) a larger Blue orifice GA4232 (GFI #7587) is available to provide the same flow. Leave humidistat set at the recommended setting.

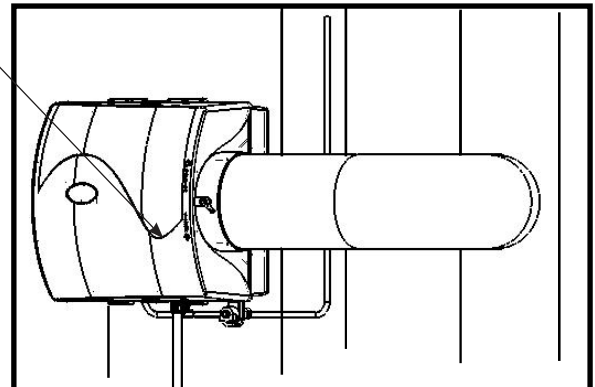

How the Humidifier Works

- The operating principle of the humidifier is based on the most efficient and economical means of evaporating water to the air. The humidifier uses only 2.5 watts of electrical power during operation, less than the smallest household light bulb. The heat necessary for evaporating water is produced by the furnace. The water supply to the humidifier is controlled by the electric solenoid valve. The humidistat connected in series with the solenoid provides low voltage control of the humidifier. The humidistat is designed for wall mounting in the living area or surface mounting on the return air duct.
- Water flows through a strainer, is metered through an orifice to provide the proper amount of water, and is supplied to the Vapor Pad[®] by the distributor trough. Approximately 200 CFM of air is by-passed from the warm air plenum through the humidifier and returned to the cold air plenum. Moisture is evaporated to the air passing through the Vapor Pad[®].
- Minerals are not blown into the air stream as occurs in atomizing humidifiers; they are left on the Vapor Pad[®] where a high percentage is carried off with the waste water.
- When the humidifier is installed and operating, no adjustments are necessary other than setting the control knob on the humidistat to the desired level of humidification. Set knob on the humidifier to "HI" or "WINTER" position. To turn the humidifier off, close the water supply valve, switch electrical power off and turn the humidistat off. If furnace is used for summer cooling or ventilating set air damper on "LOW" or "SUMMER".

At Outside Temperature		Recommended Setting
-20°F	-29°C	15%
-10°F	-23°C	20%
0°F	-18°F	25%
+10°F	-12°C	30%
+20°F	-7°C	35%
+30°F	-1°C	40%



CAUTION: Do not set relative humidity too high during cold weather. Excessive humidity may cause condensation on windows or in walls. Refer to recommended settings as described in the humidistat owners manual.

Maintenance

Your Humidifier is engineered to give helpful and trouble-free humidification. For maximum efficiency the following cleaning procedures should be carried out at the end of each heating season:

- Turn off water supply and electrical power to humidifier.
- Remove cover, water distributor trough, Vapor Pad[®], pad rails and drain pan. Clean excessive mineral deposits from the distributor trough, drain pan, pad rails and humidifier cabinet. A solution of 1/2 vinegar & 1/2 water will help loosen mineral deposits. Inspect drain hose, clean or replace as necessary.
- Insert a new GA23 (GFI #7923) Vapor Pad[®] (black notch on top). Install trough, pad rails and drain pan. Replace cover, reconnect electrical plug. Replace Vapor Pad[®] yearly for peak performance.
- In heavy mineral areas, or if the solenoid valve fails to function, disconnect the 1/4" water supply line from the solenoid valve. Carefully pull the strainer screen from the valve body. Clean the mineral deposits from all parts. If the orifice is clogged, it may be opened by inserting a small pin. Reinsert the filter into the valve body.
- Reconnect the 1/4" water line to the solenoid valve if necessary. Turn on the water supply and check all points for leakage. The operation of the unit may be checked by starting the furnace. The humidifier operates only when the furnace blower is running or the burner circuit is energized. The humidifier is now ready for operation.
- During the summer, turn off water supply and electrical power to humidifier.

Parts Drawing

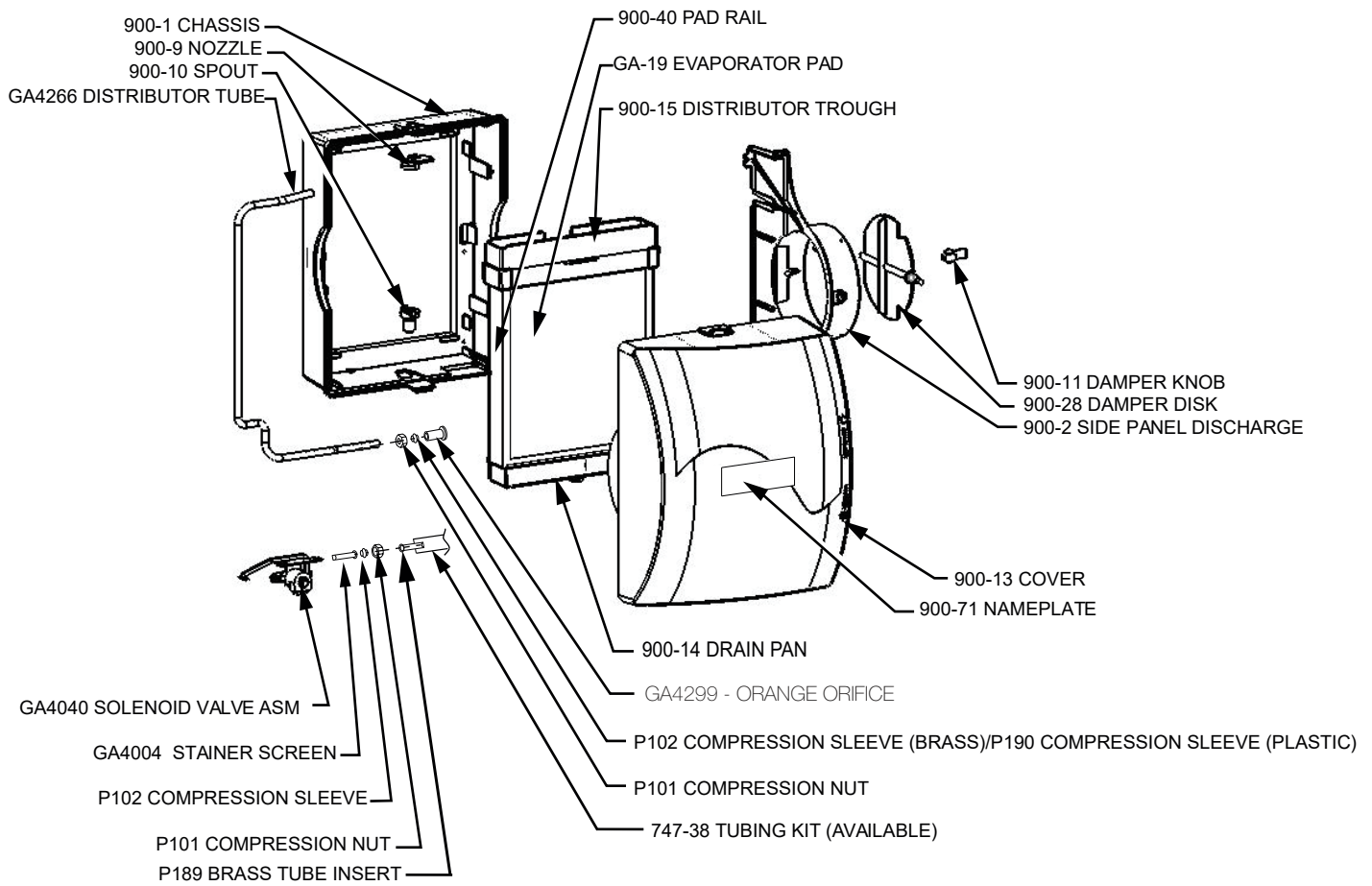

Humidifier Chassis Duct Cut Out

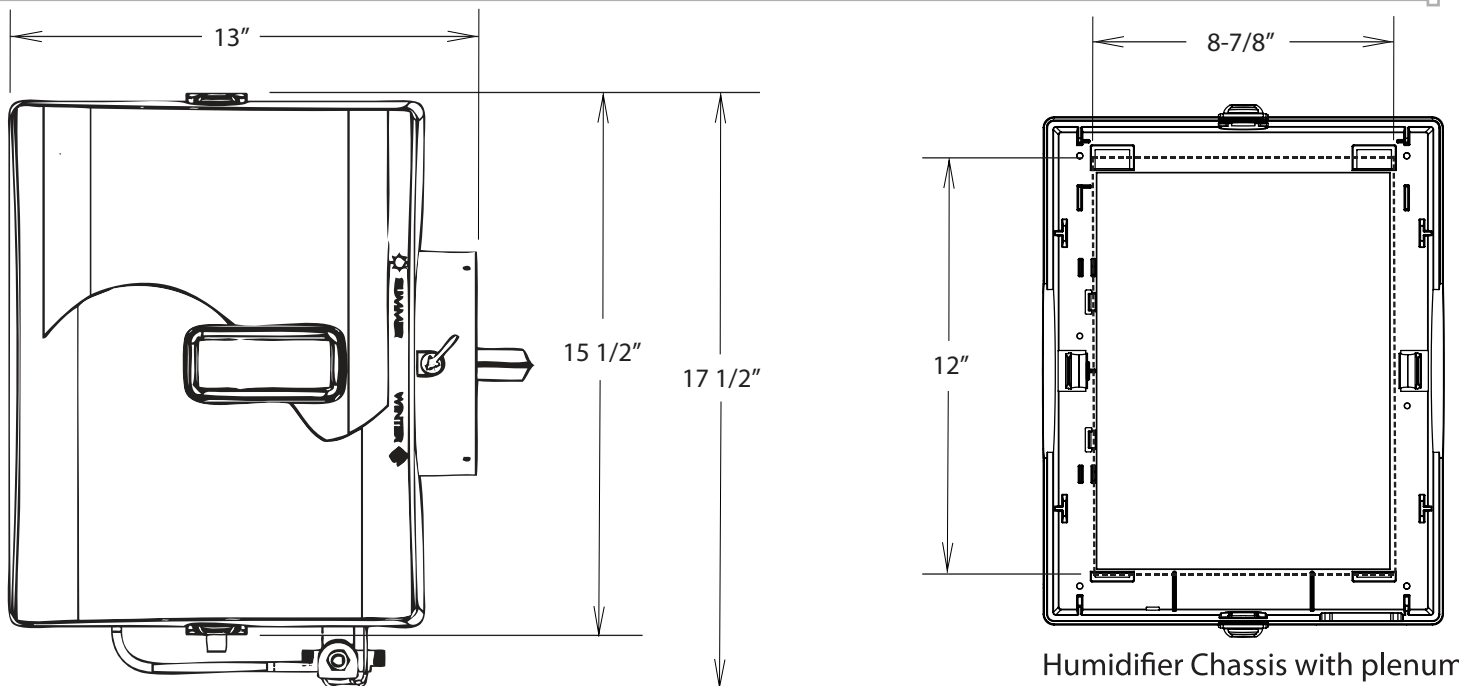

Troubleshooting

1. My humidifier continues to run.

Check for the following:

- The valve might be stuck in the "open" position.
- Check for wiring errors.
- Is the unit sized properly for your home? If it is rated for a smaller-sized home than the home in which it is installed, it will work "overtime" to reach the humidification levels desired.
- Check the Vapor Pad®. If it is clogged, the pad will reduce the humidifier efficiency. Replace if necessary.

2. My solenoid valve is making a "chatter" noise.

This can be caused by any of the following:

- The power to the valve is less than 18V AC.
- The solenoid is causing a "water hammer condition" thru the water pipes (valve closes quickly and shuts off water flow, which in turn creates pressure behind the valve that has no avenue of relief). You may want to install a water hammering device with your plumbing, or contact your local plumber to determine the best solution.
- The humidistat is located too close to the humidifier or the by-pass pipe. Your humidistat should be a min. of 1.5' away or greater.
- The humidistat could have a buildup of dust, causing a faulty reading.
- The solenoid valve might be dirty. Remove, inspect and clean if necessary.
- Water supply pressure going to the valve may be too low.
- The hold down nut on top of the solenoid, as it may be loose.

3. The humidifier is not raising the humidity levels in my home.

Check for the following:

- Ensure you have changed / replaced your Vapor Pad® at the proper intervals (once per year) to ensure the greatest production of moisture.
- Check the setting of your humidistat to ensure it is set higher than current humidity levels in your home (when in doubt, turn it all the way to the right at maximum production). If you don't know what your current humidity level is, use an instrument called a thermohygrometer (Model 610; GFI #7065 suggested) to measure both heat and humidity levels in your home.
- Calculate your humidity load (Gallons Per Day - GPD) via our humidity calculator (www.generalfilters.com/SupportCenter). Check to see that your humidifier model is designed to produce the amount of moisture (GPD) you need.
- Have you recently installed hardwood floors? Have you recently remodeled and added on to your home? These can both increase your home's demand for humidity. Options include connecting your humidifier to the hot water supply (which can increase output by as much as 30%), or installing a new humidifier model that can generate more humidity.
- The unit is not recommended for heat pumps or plenum temperatures < 120° F.

4. My humidifier will not turn on.

The following might be occurring:

- Check to see your humidifier is plugged in, that the breaker is engaged, and that power to other items from the same source is working.
- Check the on/off switch to be sure it is in the O (Open / Summer) position.
- Ensure a fuse has not blown.
- Check that connectors are properly inserted in the terminal block.
- Make sure the furnace is operating in the heat mode.



To ensure your safety and the longevity of your unit, we recommend contacting a licensed contractor to perform any repairs or maintenance.

BREATHE HEALTHIER
GeneralAire®

www.generalfilters.com

FAQ's

1. How does a humidifier help with my allergies?

Dry air can lead to a host of problems for allergy and asthma sufferers. Dry climates, winter air, and artificial heat all contribute to the discomfort by drying out your skin, throat and delicate sinus passages and airways (which can contribute to sinusitis). Winter is an especially bad time for dry air as home heating systems, especially forced-air systems, reduce the amount of moisture in the air while humidity levels outdoors typically dip as well.

2. What range of humidity is ideal?

Research shows that 40-60% relative humidity is ideal. Outside this range, your risk of being adversely affected increases.

3. How often should I change my Vapor Pad®?

We recommend replacing your Vapor Pad® at least once per year. Minerals build up on the vapor pad over time, which in turn:

- Reduces the pad's ability to absorb water.
- Prevents the warm air from flowing through the pad (Warm air moving through the water-soaked pad causes the water in the pad to evaporate. It is this process that delivers moisture throughout your home via the home's duct system).

4. Can't I simply clean my Vapor Pad® instead of replacing it?

At the factory we put a coating on the Vapor Pad® that helps it absorb water and control water flow. This coating is very efficient, however, it is also fragile. The coating is similar in composition to the minerals that accumulate on the pad. If you subject the Vapor Pad® to cleaning, you usually remove much of the coating and the pad becomes ineffective. This reduces the output of the humidifier and increases water consumption.

Instead we recommend the Vapor Pad® be replaced each year.

5. Why would I want to install a humidifier?

For many reasons:

1. Since the air in your home is always trying to reach its saturation point, it will absorb water wherever it can; from the bodies of you and your children, your pets, your furniture and even your house plants. As a result your skin, throat and nasal passages dry out, leaving you more susceptible to physical discomfort, colds, flu and even infection. Allergy and asthma sufferers can be especially affected by air that's too dry.
2. Dry air causes dry, itchy skin.
3. Dry air cracks expensive woodwork, floors, musical instruments, artwork and furnishings.
4. Annoying static electricity (caused by dry air) can damage computers, VCR's and other electronic equipment, requiring expensive repair.
5. Dry air can cause harm to expensive musical instruments like pianos and violins.
6. Dry air causes gaps in window & door frames, letting cold outdoor air in; causing you to turn up the heat and increasing your heating bills! Controlled humidity from a GeneralAire® Humidifier allows you the luxury of dialing the thermostat back & reducing annual heating bills. For example, 68° at 40% relative humidity feels just as warm as 74° at 20% humidity. Setting your thermostat back by as little as three degrees can reduce annual heating bills by as much as 5%.

Limited Warranty

What is Covered

- Five Years: The 1099LHS, if properly registered by the return of the warranty registration card to the manufacturer, is warranted by General Filters, Inc. ("Company") for a period of five (5) years from the date of the original installation, when installed in residential applications only ("Limited Warranty Period").
- One Year: The Humidistat
- This Limited Warranty runs to the original purchaser of the Product(s) who owns, and resides in, the residential property for which it is installed and maintained.
- The Limited Warranty coverage begins upon the date the Product(s) is installed.
- This Limited Warranty is valid only for the original customer purchasing from Company, and is not transferable.

What is Not Covered

- The following components are not covered by this warranty: Vapor Pads, sleeves or plates, wiring, water strainers or metering orifices.
- This product is designed for residential installation only, therefore, commercial or industrial installations are not covered under this warranty.
- Failure to install the 1099LHS in accordance with these instructions, local codes or ordinances voids the warranty.
- Modifications, changes or alterations to equipment.
- Failure to perform regular maintenance as described in this document voids the warranty.
- This Limited Warranty is valid only for the original customer purchasing from Company, and is not transferable.
- Damage caused by misuse, neglect, fire, wind, mold, damage in transit, or other casualty, contact with corrosive materials (chlorine, fluorine, salt, urine, fertilizers, recycled waste water, or other damaging substances), damage caused during installation, or any cause beyond General Filters, Inc. control is not covered under this Limited Warranty.
- Labor involved in diagnostic calls or in removing, repairing, servicing or replacing parts is not covered under this Limited Warranty.

What is Not Covered, Cont.

- Shipping charges are not covered by this Limited Warranty.
- Agreements made by third parties that are not listed in this Limited Warranty.
- Liability for special, incidental, direct, indirect, collateral and consequential damages is excluded. Some states do not allow limitation of incidental damages, so the limitations or exclusions may not apply to you. General Filters, Inc. will not pay electricity or fuel costs, or increases in electricity or fuel costs, for any reason whatsoever, including additional or unusual use of supplemental electric heat. This warranty does not cover lodging expenses or labor charges. General Filters, Inc. shall not be liable for any default or delay in performance under this warranty caused by any contingency beyond its control. This warranty gives you specific legal rights, and you may also have other rights which vary from state to state.

To Make a Warranty Claim / Obtain Service

- Owner must submit a warranty registration within 30 days after installation of Product(s).
- The Owner must complete our online Return Merchandise Authorization (RMA) Form (www.generalfilters.com/returns), to arrange for applicable Limited Warranty service, within the warranty period. Owner must also provide complete model and serial number, proof of required periodic maintenance, installation date and location and an accurate, detailed description of the problem.
- Owner shall be solely responsible for properly packaging the Covered or Extended Coverage Equipment, for all freight charges, and for all risk of loss associated with shipment.
- Owner is responsible for obtaining a licensed contractor to perform any repairs, maintenance or other work on unit.
- If during the Limited or Extended Warranty Period, Covered or Extended Coverage Equipment fails because of a manufacturing defect, Company will provide a free replacement part to the Owner through a licensed service contractor.



Limited Warranty Cont.

Limitations of Liability

- General Filters, Inc. makes no express warranties other than the warranty specified above.
- The implied warranties of merchantability and fitness for a particular purpose are limited to the duration listed.
- The manufacturer assumes no liability in connection with the installation or use of the product, except as stated in this Limited Warranty.
- The manufacturer will in no event be liable for incidental or consequential damages.
- This limited warranty gives you specific legal rights, and you may also have other rights which vary from state to state. Some states do not allow either limitations on implied warranties, or exclusions from incidental or consequential damages, so the above exclusion and limitation may not apply to you.

Questions

- Any questions pertaining to this limited warranty should be addressed to the manufacturer. (U.S.A.: The manufacturer has elected not to make available the informal dispute settlement mechanism which is specified in the Magnuson-Moss Warranty Act.)

The rest of this page left intentionally blank.

