

# INSTRUCTION MANUAL

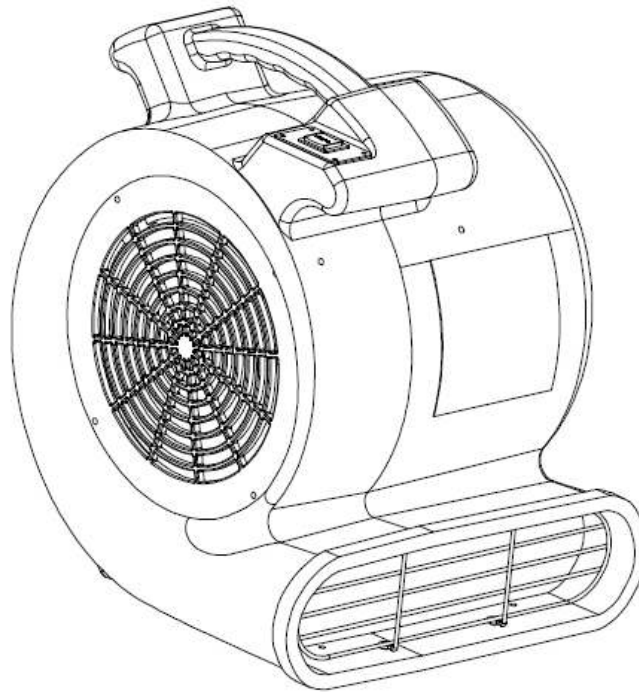

**641763**

1/2hp Air Mover

**READ ENTIRE MANUAL BEFORE**

Global Industrial-11 Harbor Park Drive Port Washington-NY 11050

# Safety Instructions

Please observe the following safety instructions to avoid personal injury and property loss.

- 1) Do not operate any fan with a damaged cord or Plug.
- 2) Do not move or adjust blower while in operation
- 3) Keep this unit out of the reach of children
- 4) Do not alter or modify your blower in any way. Only authorized Global Industrial replacement parts can be used. Use of any unauthorized parts could cause hazards and void the unit's warranty
- 5) Always store unit in a clean, dry environment when not in use. Care should be taken to prevent water from entering the unit's motor. In the case that the unit's motor does become wet, ensure that the motor is dried thoroughly before use.
- 6) Do not allow water near or inside the unit while in use to avoid risk of electric shock. Handle unit with care to avoid causing damage or personal injury.
- 7) Always operate the blower on a flat, level surface. Operating the unit where it could slip or fall increases the risk of injury, fire, or electrical shock.
- 8) Never operate the blower without the factory-installed safety screens in place. This will prevent liquids, gases, and other materials from entering the blower.
- 9) Do not use blower near combustible gas or flammable materials in order to avoid fire or electrical hazards.
- 10) Do not attempt to disassemble or repair unit on your own. Instead, bring to the attention of your distributor or a certified repair center. Never attempt to disassemble or repair unit while blower is plugged in.
- 11) Prior to use, ensure the air intake and outlet are free of obstructions to prevent the blower from overheating

# Operating Procedures

The Global Industrial line of commercial ventilator is designed to efficiently and effectively ventilate, extract and circulate air. Be sure to follow all instructions below to ensure safe and effective use.

- 1) Ensure that the unit is on a stable, level surface, and remains stationary while in use.
- 2) Plug the blower into a grounded outlet with the correct voltage and amperage. Ensure that the unit is plugged into a grounded outlet with voltage and wattage outputs that correspond with the unit's specifications. For maximum protection against electrical shock, ALWAYS use a circuit that is protected by a ground fault circuit interrupter. If you are unsure about the outlet, check with a qualified electrician.
- 3) Ensure that the dial is turned to your desired speed setting before turning the unit on.

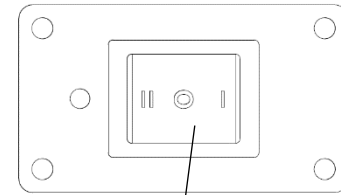

Switch Knob

## Maintenance

- 1) Inspect the electrical cord and wiring for damage or discoloration before use. NEVER use a blower that has a damaged cord to avoid risk of electrical shock or fire.
- 2) Inspect for loose fasteners before each use.
- 3) Clean safety screens of the unit before each use.
- 4) Listen for abnormal sounds and shut unit off immediately upon hearing unusual noises.
- 5) Keep unit clean and free of blockages or obstructions.
- 6) Use compressed air or a vacuum to remove lint and other debris from the motor, inlet, or fan blade.
- 7) Do not use a pressure washer, water hose, or other water source to clean the unit. Ensure that the unit is completely dry before each use.
- 8) The blower has sealed bearings and cannot be lubricated. No oiling is necessary.

**For information about authorized repair and maintenance contact Global Industrial.**

## Specifications

Model	641763
Power Input	115Volt/60hz
Power	1/2hp
Current	5.0amps(Max)
Motor Speed	1100rpm
Air Volume	2200cfm
Size	18.5x16.1x15.4inch
Weight	26.4lbs

Specifications may change without notice.

# Trouble Shooting

<b>BLOWER DOES NOT TURN ON</b>	<ol style="list-style-type: none"><li>1) Switch not turned on - in this case, ensure that the knob is in the correct position to turn the unit on</li><li>2) Circuit breaker or GFCI has tripped - press 'reset button before attempting to turn the unit on</li><li>3) Cord or wires are loose or damaged - Inspect to ensure that cords and wires are tight and free of damage</li><li>4) Faulty switch - Contact your distributor if inside warranty period</li></ol>
<b>BLOWER STARTS AND THEN TURNS OFF</b>	<ol style="list-style-type: none"><li>1) Obstructed inlet/outlet - remove obstructions and ensure that both inlet and outlets are clear before use.</li><li>2) Faulty motor - Contact your distributor if inside warranty period</li></ol>
<b>BLOWER VIBRATES</b>	<ol style="list-style-type: none"><li>1) Motor shaft is bent - Contact your distributor if inside warranty period</li><li>2) Fan blade is bent - Contact your distributor if inside warranty period</li><li>3) Excessive dirt built up on fan blade - Clean blade and ensure blade housing is free of dust and dirt before use</li></ol>
<b>BLOWER MAKES SCRAPING NOISES</b>	<ol style="list-style-type: none"><li>1) Damaged housing - Inspect housing for warps or dents. If housing is rubbing against blade, contact your distributor.</li></ol>
<b>MOTOR MAKES NOISE, BUT BLOWER WON'T TURN ON</b>	<ol style="list-style-type: none"><li>1) Damaged/faulty motor or motor shaft - Contact your distributor if inside warranty period</li><li>2) Motor shaft screw holding fan blade is loose - tighten</li></ol>