

A2L ACCESSORY / ZONING CONTROL KIT

INSTALLATION INSTRUCTIONS

ATTENTION INSTALLING PERSONNEL

As a professional installer, you have an obligation to know the product better than the customer. This includes all safety precautions and related items.

Prior to the actual installation, thoroughly familiarize yourself with this instruction manual. Pay special attention to all safety warnings. Often during installation or repair, it is possible to place yourself in a position which is more hazardous than when the unit is in operation.



Remember, it is your responsibility to install the product safely and to know it well enough to be able to instruct a customer in its safe use.

Safety is a matter of common sense. A matter of thinking before acting. Most dealers have a list of specific good safety practices. Follow them.



The precautions listed in this installation manual are intended as supplemental to existing practices. However, if there is a direct conflict between existing practices and the content of this manual, the precautions listed here take precedence.

SAFETY PRECAUTIONS

The following symbols and labels are used throughout this manual to indicate immediate or potential safety hazards. It is the owner's and installer's responsibility to read and comply with all safety information and instructions accompanying these symbols. Failure to heed safety information increases the risk of personal injury, property damage, and/or product damage.

	WARNING
HIGH VOLTAGE DISCONNECT ALL POWER BEFORE SERVICING THIS UNIT. MULTIPLE POWER SOURCES MAY BE PRESENT. FAILURE TO DO SO MAY CAUSE PROPERTY DAMAGE, PERSONAL INJURY OR DEATH.	
	

If the installation check, as detailed in these installation instructions, does not pass successfully, please call 1-855 DAIKIN1, option 3 for further assistance.

	WARNING
DO NOT BYPASS SAFETY DEVICES.	
	WARNING
<p>ONLY PERSONNEL THAT HAVE BEEN TRAINED TO INSTALL, ADJUST, SERVICE, MAINTENANCE OR REPAIR (HEREINAFTER, "SERVICE") THE EQUIPMENT SPECIFIED IN THIS MANUAL SHOULD SERVICE THE EQUIPMENT.</p> <p>THIS EQUIPMENT IS NOT INTENDED FOR USE BY PERSONS (INCLUDING CHILDREN) WITH REDUCED PHYSICAL, SENSORY OR MENTAL CAPACITIES, OR LACK OF EXPERIENCE AND KNOWLEDGE, UNLESS THEY HAVE BEEN GIVEN SUPERVISION OR INSTRUCTION CONCERNING USE OF THE APPLIANCE BY A PERSON RESPONSIBLE FOR THEIR SAFETY.</p> <p>CHILDREN SHOULD BE SUPERVISED TO ENSURE THAT THEY DO NOT PLAY WITH THE EQUIPMENT.</p> <p>THE MANUFACTURER WILL NOT BE RESPONSIBLE FOR ANY INJURY OR PROPERTY DAMAGE ARISING FROM IMPROPER SUPERVISION, SERVICE OR SERVICE PROCEDURES. IF YOU SERVICE THIS UNIT, YOU ASSUME RESPONSIBILITY FOR ANY INJURY OR PROPERTY DAMAGE WHICH MAY RESULT. IN ADDITION, IN JURISDICTIONS THAT REQUIRE ONE OR MORE LICENSES TO SERVICE THE EQUIPMENT SPECIFIED IN THIS MANUAL, ONLY LICENSED PERSONNEL SHOULD SERVICE THE EQUIPMENT. IMPROPER SUPERVISION, INSTALLATION, ADJUSTMENT, SERVICING, MAINTENANCE OR REPAIR OF THE EQUIPMENT SPECIFIED IN THIS MANUAL, OR ATTEMPTING TO INSTALL, ADJUST, SERVICE OR REPAIR THE EQUIPMENT SPECIFIED IN THIS MANUAL WITHOUT PROPER SUPERVISION OR TRAINING MAY RESULT IN PRODUCT DAMAGE, PROPERTY DAMAGE, PERSONAL INJURY OR DEATH.</p>	

Parts needed in kit:

- 1) 10ft RED 18 AWG wire with insulated 1/4" terminals on each side (for wiring the Alarm terminal to the HVAC unit)
- 2) 10ft BLUE 18 AWG wire with insulated 1/4" terminal on one end and cut on the other end (for wiring transformer common to the HVAC unit)
- 3) 4 10ft BLACK 18 AWG wire with insulated 1/4" terminal on one end and cut on the other end (for power wiring to accessory and to accessory power)
- 4) 4 10ft WHITE 18 AWG wire with insulated 1/4" terminal on one end and cut on the other end (for neutral or common wiring to accessory and to accessory power)
- 5) Mounting hardware (screws & wall anchors)
- 6) PCB Enclosure with Zoning PCB enclosed inside it

19001 Kermier Rd., Waller, TX 77484

www.daikincomfort.com • www.goodmanmfg.com • www.amana-hac.com

© 2024 Daikin Comfort Technologies Manufacturing, L.P.

IO-7032A
07/2024

Amana is a registered trademark of Maytag Corporation or its related companies and is used under license. All rights reserved.



The A2L Accessory / Zoning Control is designed to support R-32 refrigerant HVAC installations that use electronic accessories such as zoning, electronic air cleaners, UV lamps, humidifiers, or dehumidifiers. If these types of electronic accessories are not used in the installation, the A2L Accessory / Zoning Control is not needed. These HVAC installations must also contain a refrigerant detection system to detect leaks. If there is an R-32 refrigerant leak inside the indoor unit, the system's refrigerant detection system will turn off all HVAC functionality (cooling and heating modes) and ensure the indoor blower is running to dissipate any R-32 refrigerant gas. The A2L Accessory / Zoning Control, working with the system's refrigerant leak detection system, will make sure all zone dampers are open and any installed accessory is turned off during

an active refrigerant leak alarm. After the system's refrigerant detection system removes the leak alarm, the A2L Accessory / Zoning Control will provide power back to any installed accessory device and no longer hold any dampers in the open position. This manual will explain how to properly wire the A2L Accessory / Zoning Control to any installed accessory devices and the HVAC unit's refrigerant detection system.

The kit should never be physically mounted anywhere on the unit. The kit can be mounted to a wall near the unit, on a wood beam, on the furnace return duct or other locations deemed acceptable. The kit can be mounted using the wall anchors and screws provided with the kit. The kit must always be accessible and serviceable.

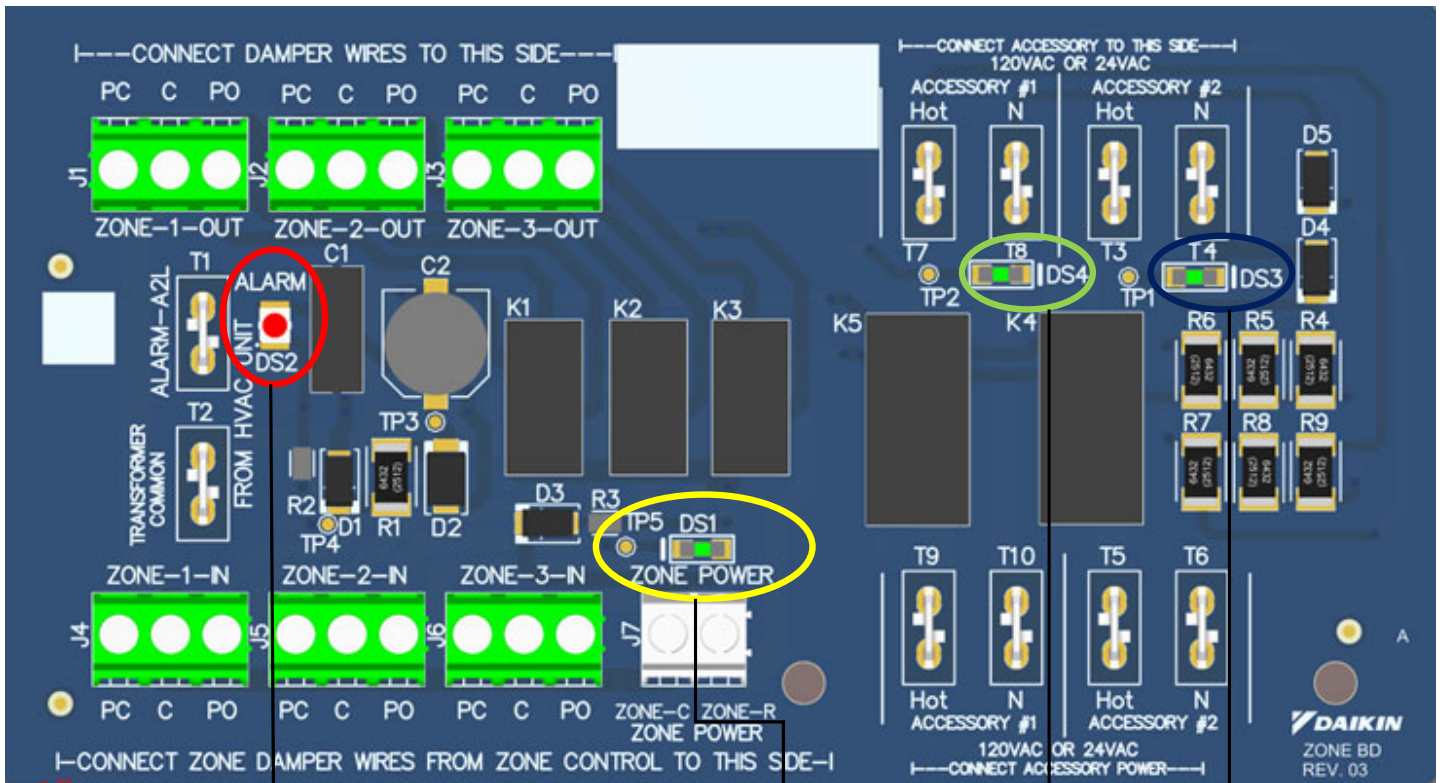

DS2, indicates when the Alarm is active

DS1, indicates Zone board has power applied

DS4, indicates Accessory #1 is powered

DS3, indicates Accessory #2 is powered

Leaderway Coahuila S.DE R.L.DE C.V:

Hangzhou Leaderway Electronics Co.,LTD



Conforms to UL STD 60730-1
Certified to CAN/CSA STD E60730-1



Conforms to UL STD 60730-1
Certified to CAN/CSA STD E60730-1

ZONING AND ACCESSORY CONTROL WIRING DIAGRAMS FOR VARIOUS ZONE DAMPERS

APPLICATIONS USING
POWER OPEN / POWER CLOSED
ZONE DAMPERS

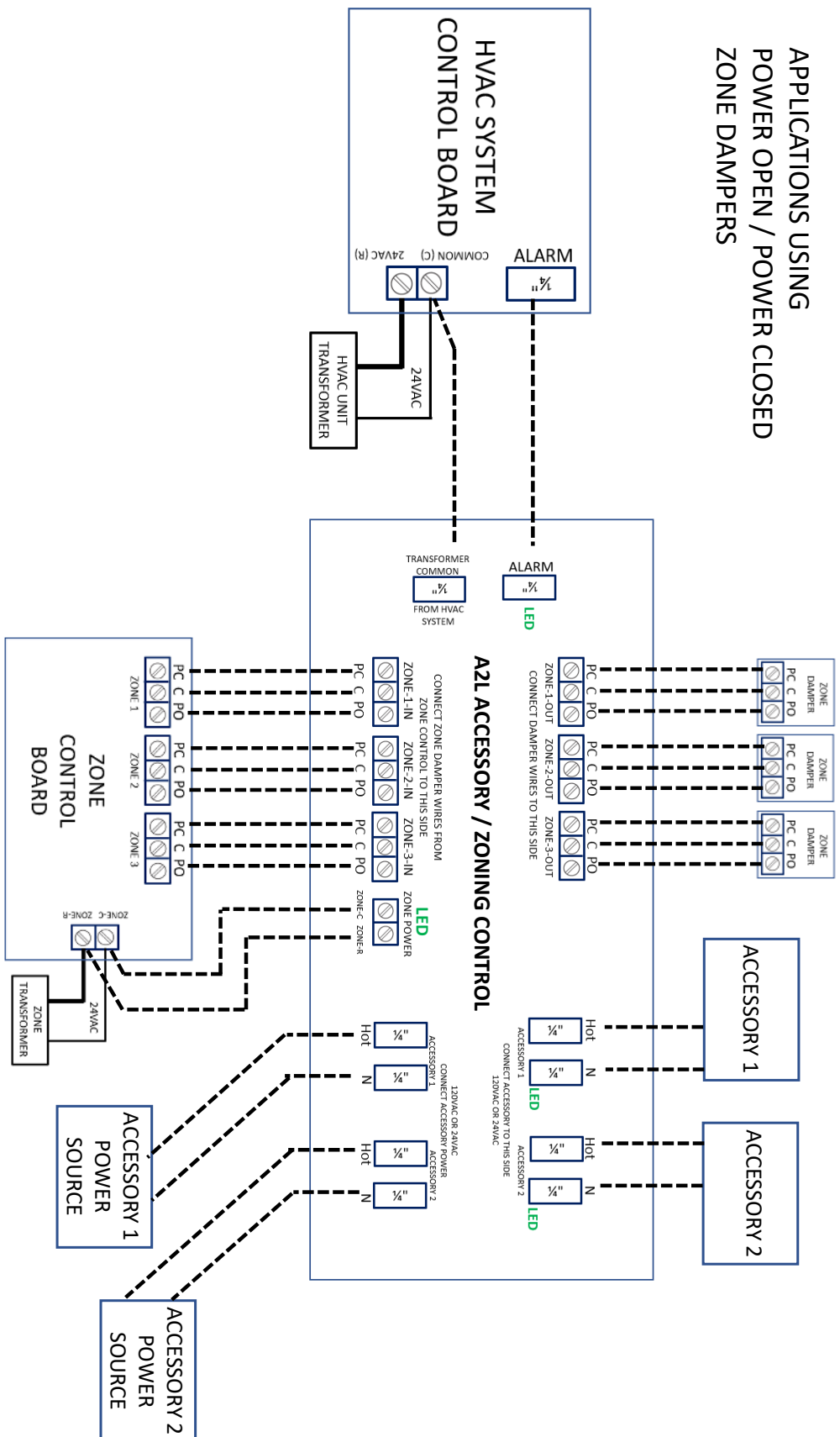

ENLARGED VIEW OF A2L ACCESSORY / ZONING CONTROL



A2L ACCESSORY / ZONING CONTROL

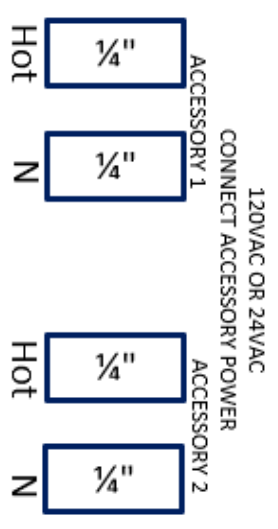
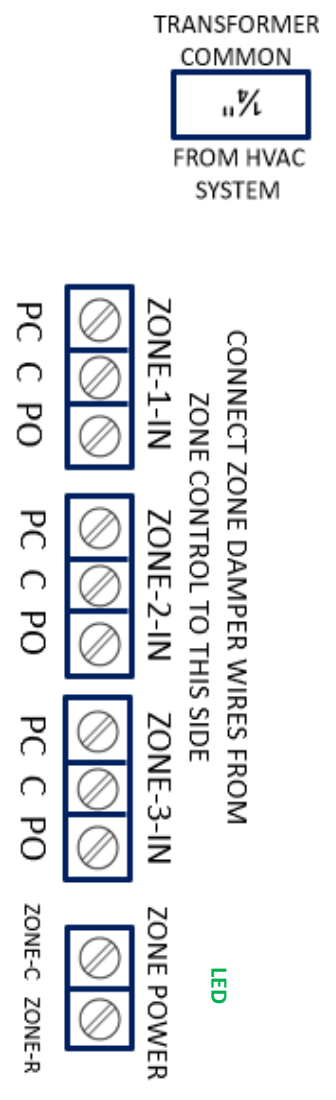
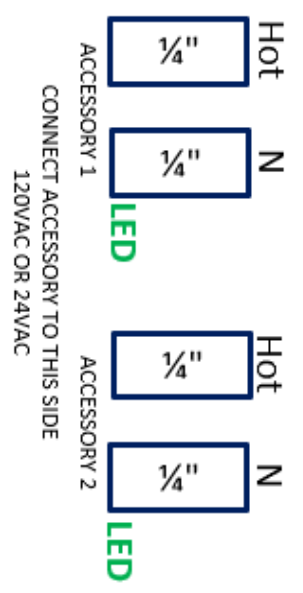

APPLICATIONS USING
POWER CLOSED / SPRING OPEN
ZONE DAMPERS

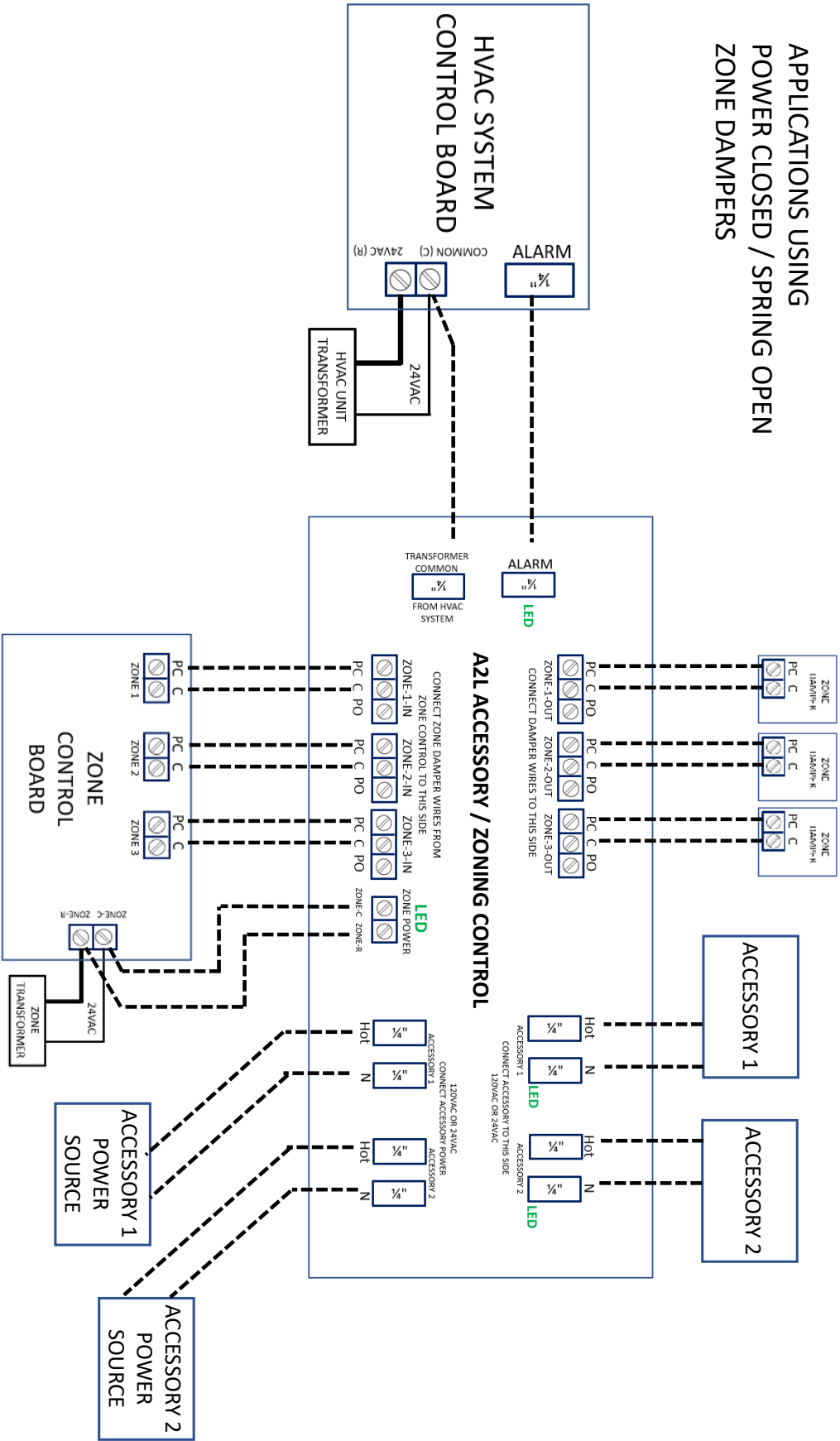

APPLICATIONS USING
POWER OPEN / SPRING CLOSED
ZONE DAMPERS

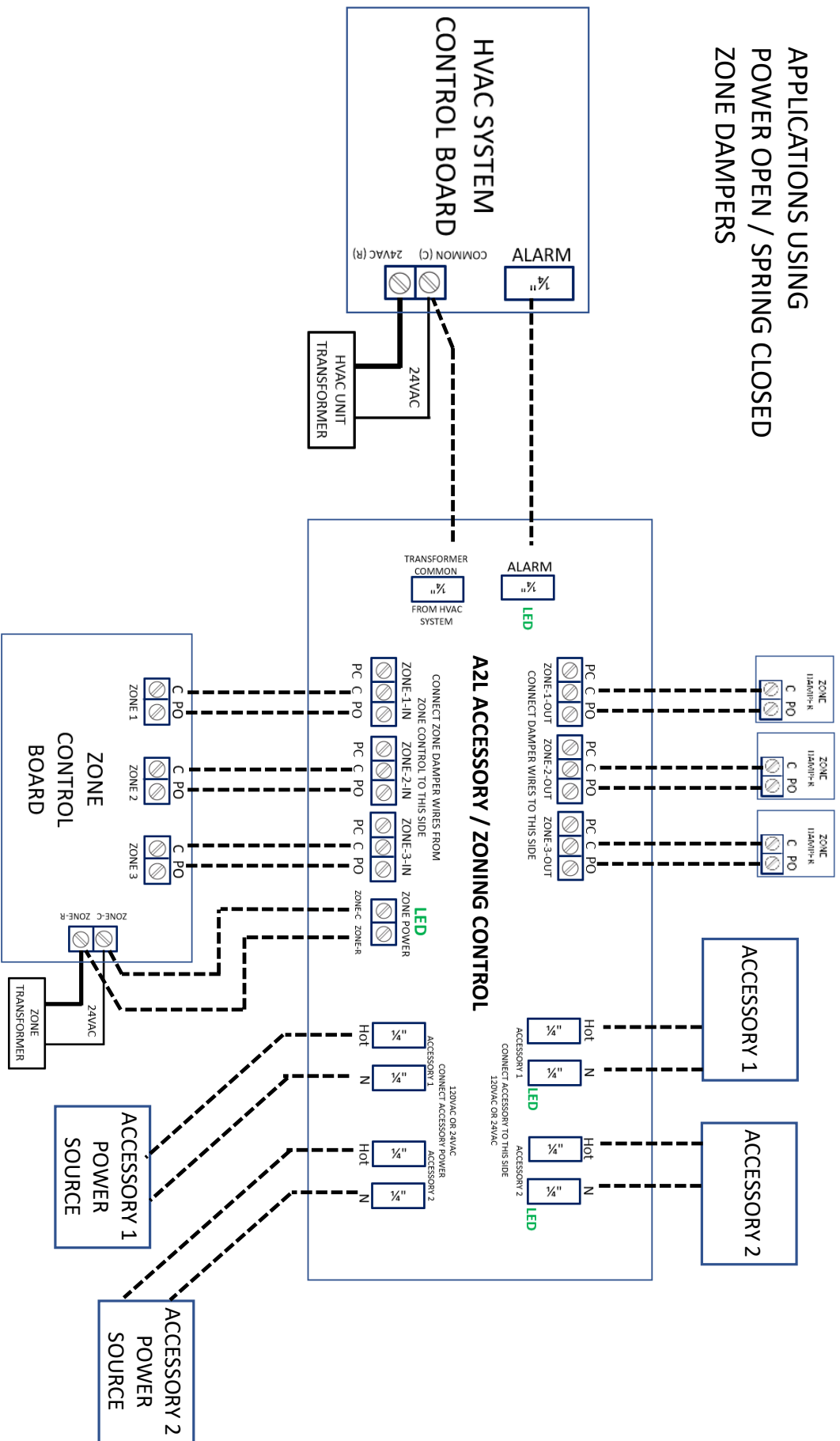

APPLICATIONS USING MORE THAN 3 ZONES OR 2 ACCESSORIES
 (example shows 4 zones with power open / power closed dampers)

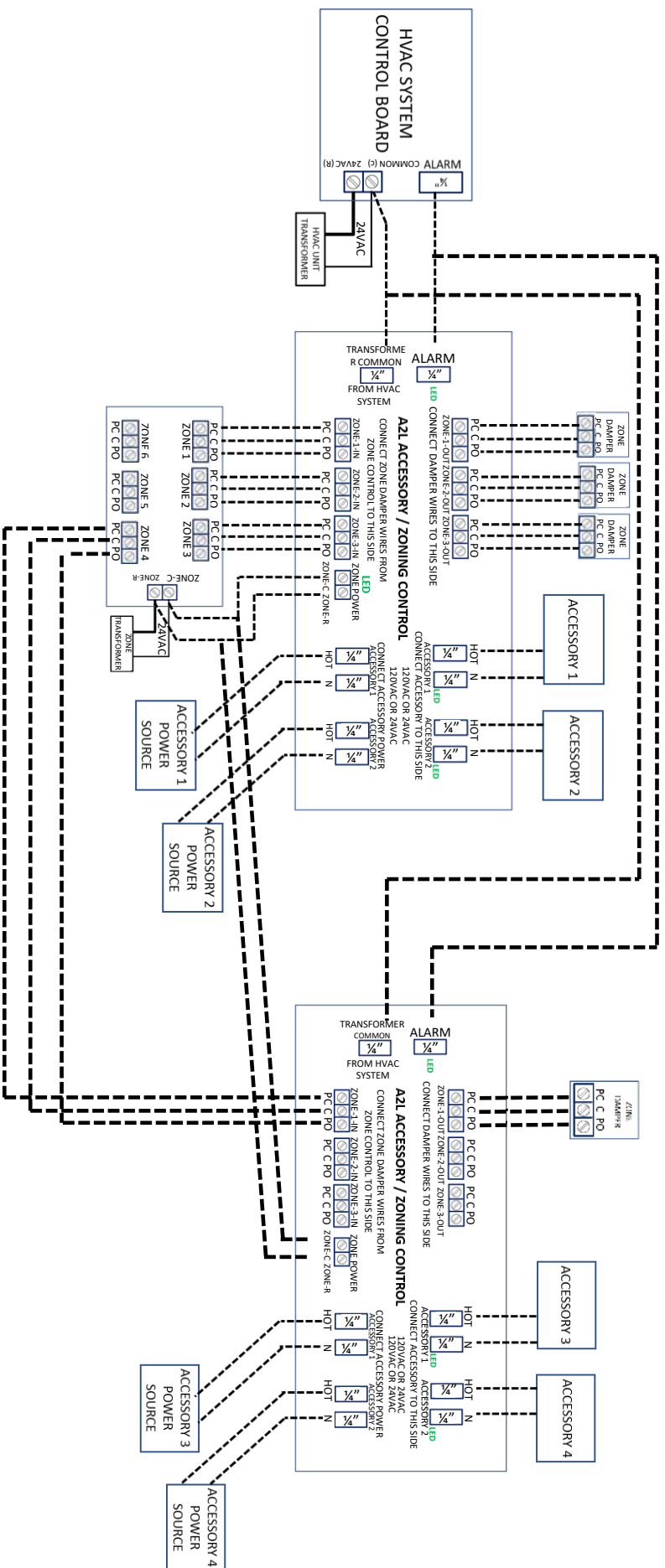

APPLICATIONS USING MORE THAN 3 ZONES OR 2 ACCESSORIES
 (example shows 4 zones with power open / spring closed dampers)

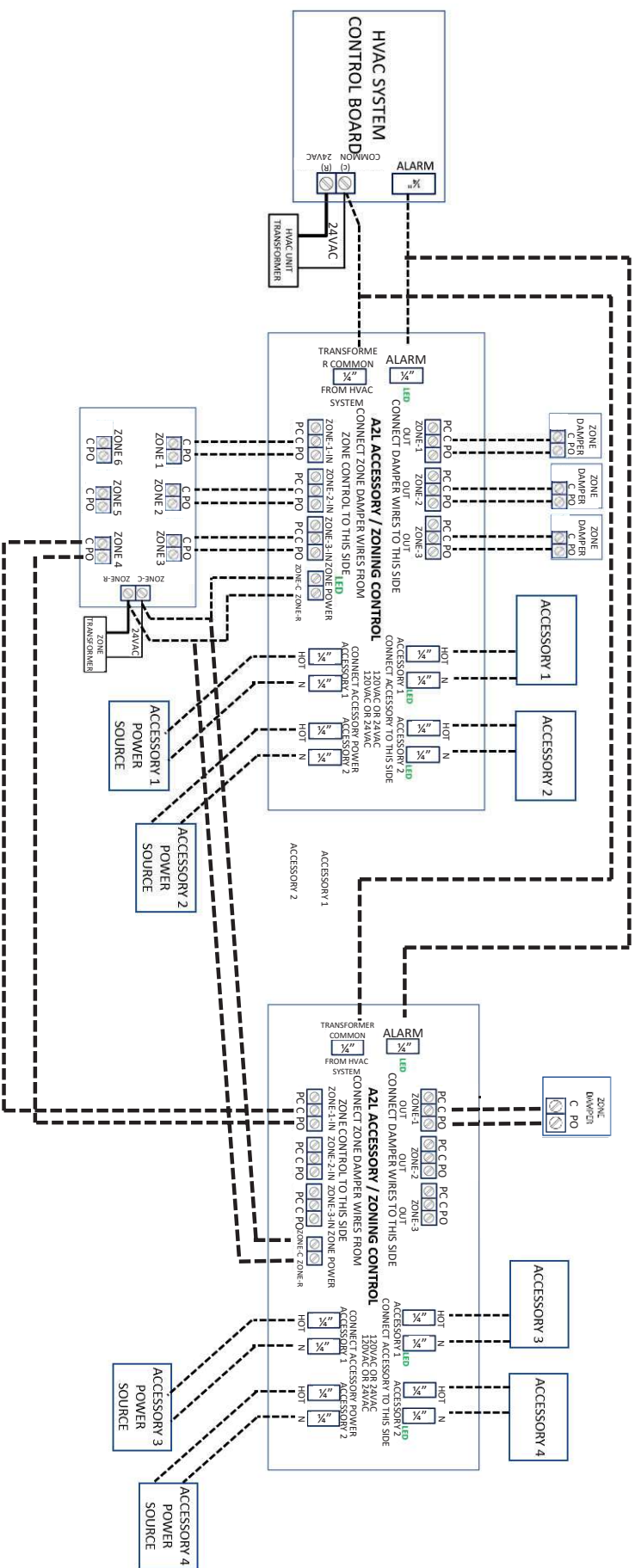

APPLICATIONS USING MORE THAN 3 ZONES OR 2 ACCESSORIES
 (example shows 4 zones with Power Closed / Spring Open dampers)

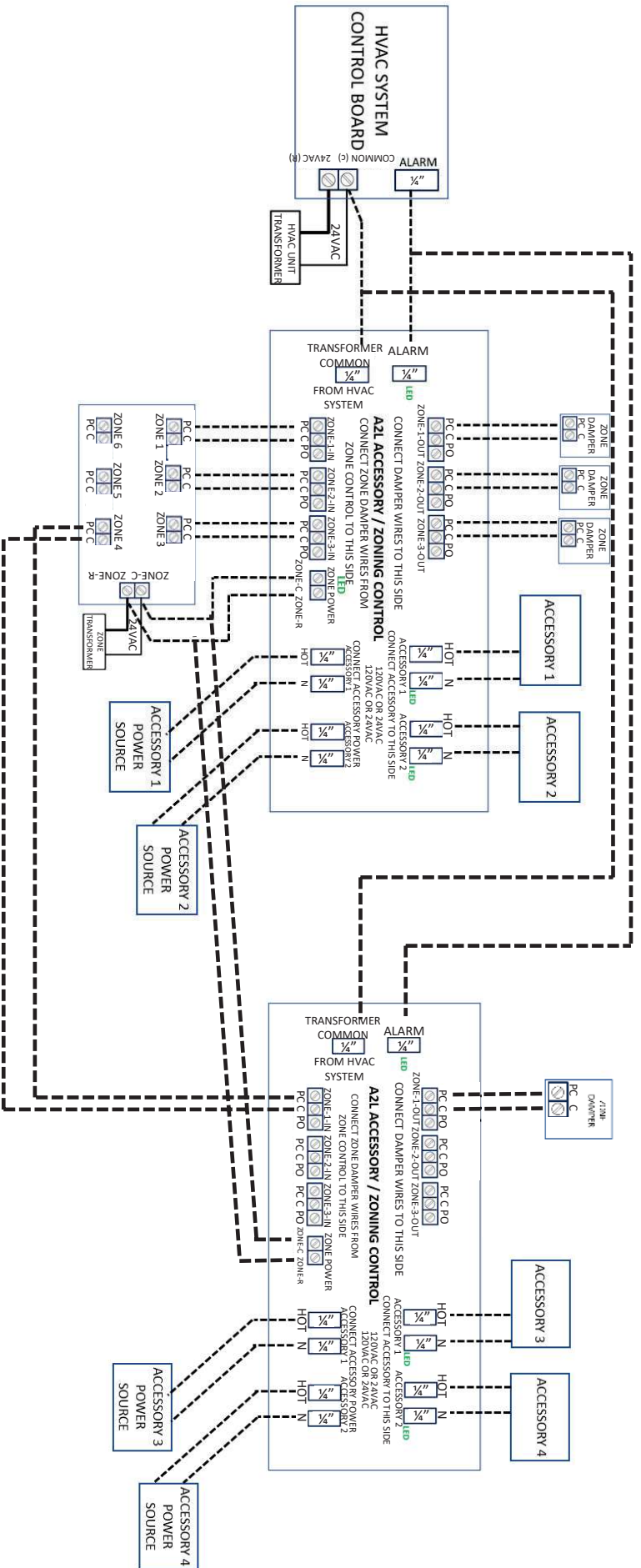

Example of Non-A2L Furnace Integration Kit
+ A2L Accessory /Zoning Control

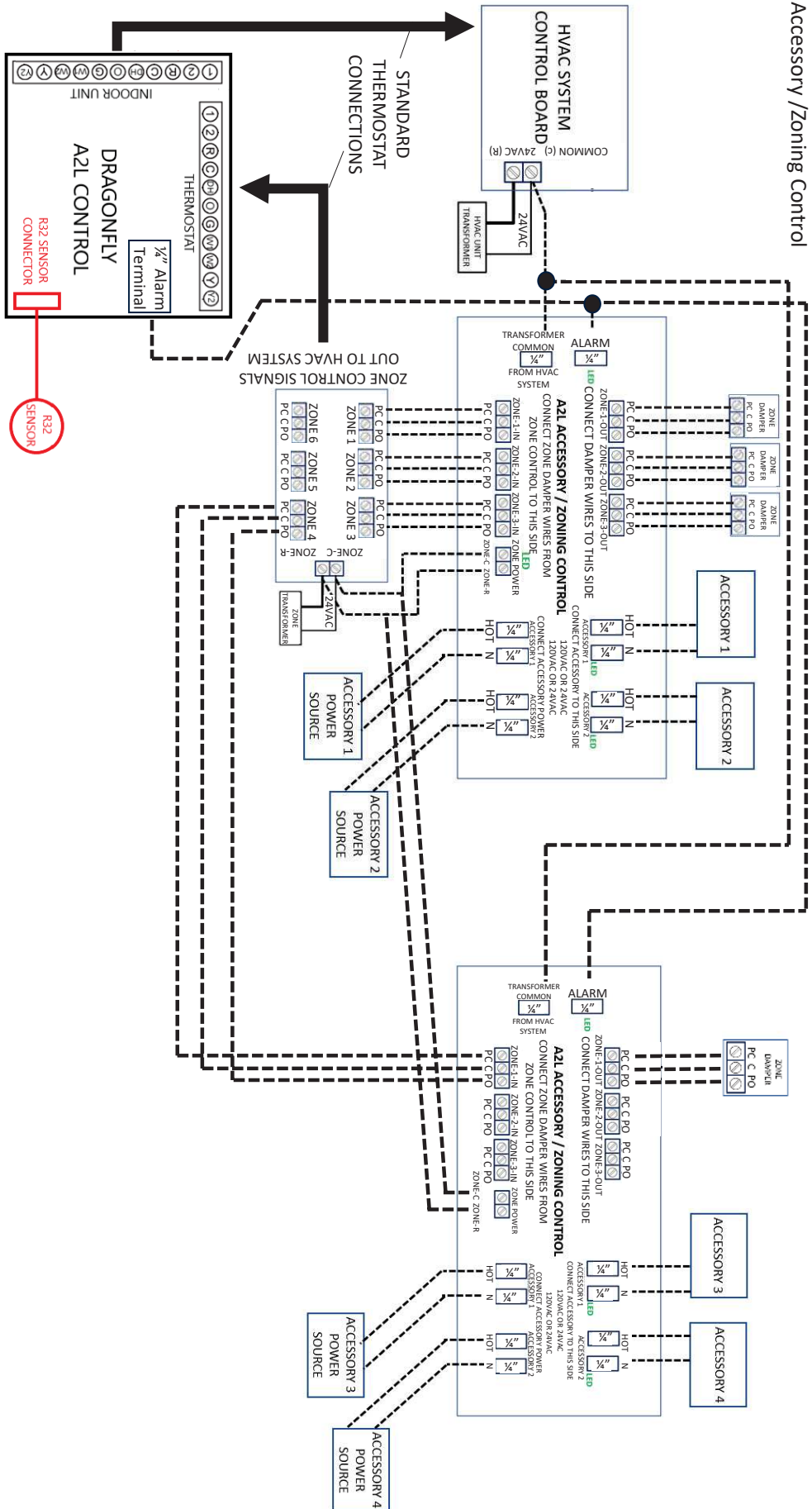

ZONE Application with CTL-COM and CTL-NO Terminals

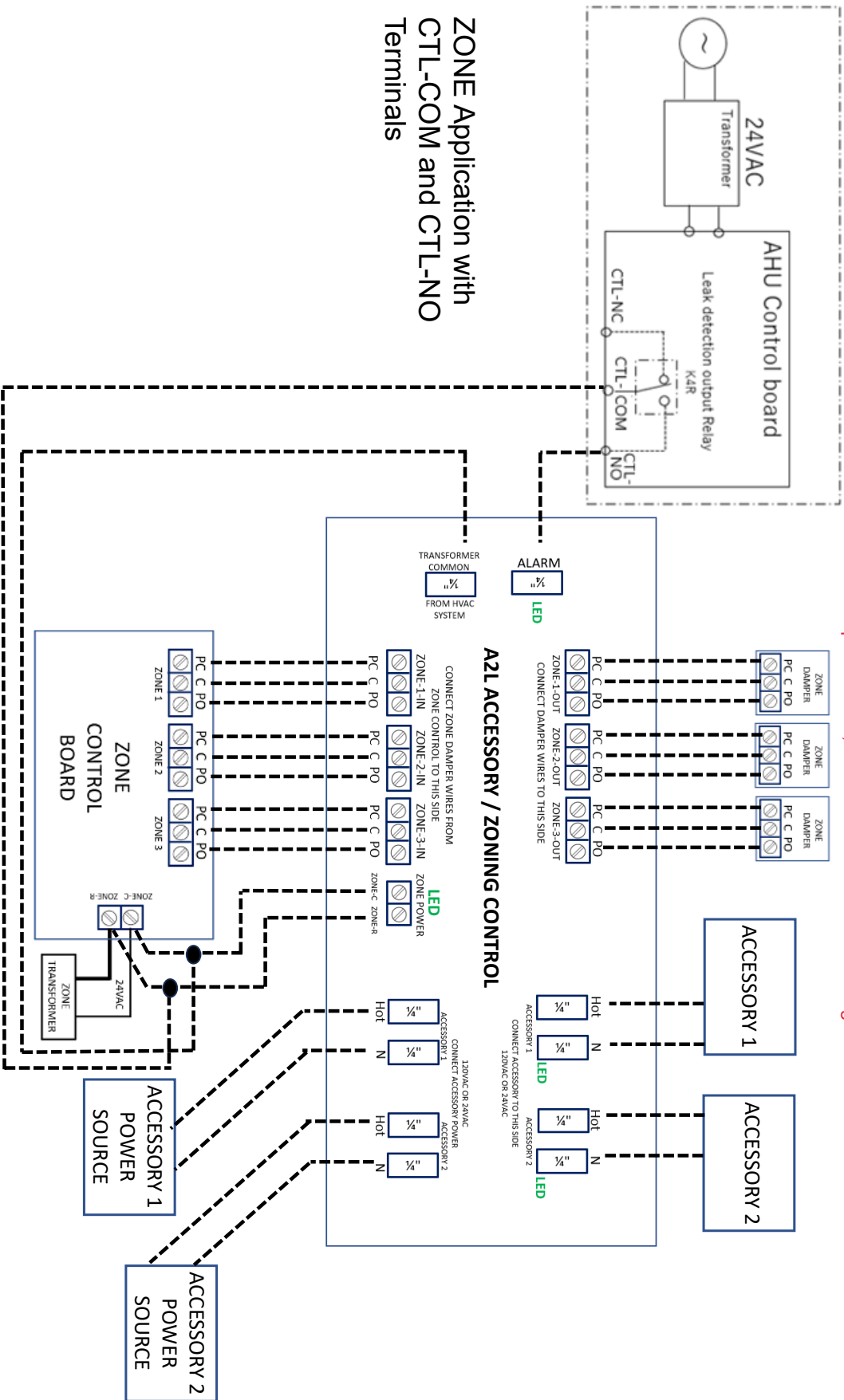

Example of DFVE, AHVE or MBVK model + Zoning control

Example of DFVE, AHVE or MBVK model + 120VAC Accessory Application

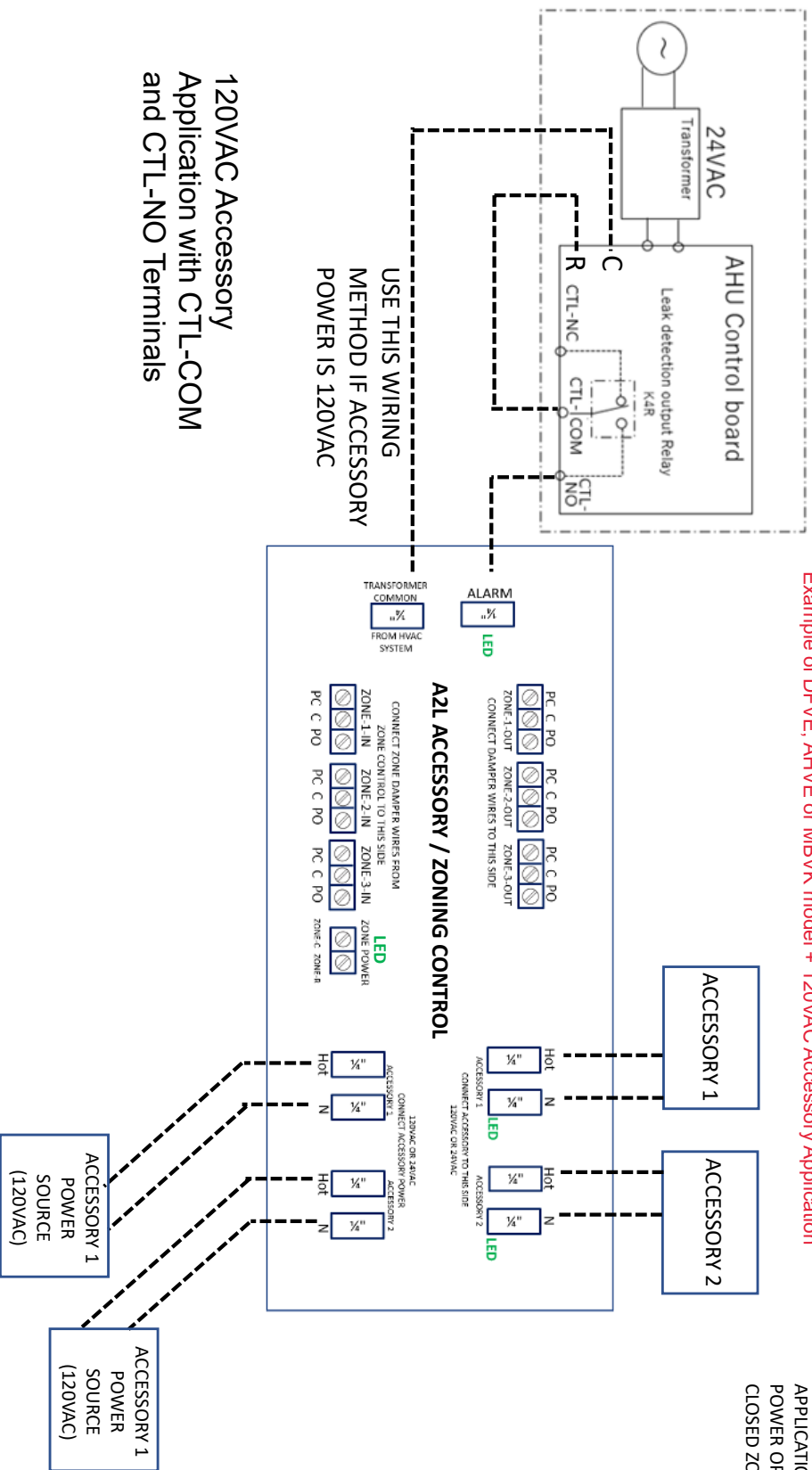

NOTE: Do not connect C and R of the communication terminal to locations other than those specified.

A2L ACCESSORY / ZONING CONTROL INSTALLATION STEPS

ZONING APPLICATIONS

The A2L Accessory / Zoning Control can support up to 3 zones. If the system uses more than 3 zones, additional A2L Accessory / Zoning Controls will be needed to support up to the remaining zones.

WIRING FOR ZONING APPLICATION

- 1) Identify the style of zoning control being used for the application. All standard zoning control systems use either 1) power open / spring closed, 2) power closed / spring open or 3) power open / power closed electronic dampers. The A2L Accessory / Zoning Control is compatible with all types of zone dampers.
- 2) Locate the appropriate wiring diagram for the type of dampers being used.
- 3) Identify the damper connection points on the zone control (if the zoning control was previously installed, the zone dampers will already be wired into these connection points)
- 4) If the zoning control was previously installed, remove the damper wires from the zone control and move them to the side of the A2L Accessory / Zoning Control labeled "CONNECT DAMPER WIRES TO THIS SIDE". If this is a new installation of the zone system, this step is not needed.
 - a. NOTE: make sure to move wires from zone 1 on the zone control to zone 1 on the A2L Accessory / Zoning Control (same for zone 2 and 3).
- 5) Per the wiring diagram identified for the type of damper being used, make the appropriate wire connections between the zone control and the A2L Accessory / Zoning Control terminals labeled "CONNECT ZONE DAMPER WIRES FROM ZONE CONTROL TO THIS SIDE"
 - a. Make sure the zones match between the zone control and the A2L Accessory / Zoning Control
- 6) If this is a new installation of the zone system, connect zone dampers to the A2L Accessory / Zoning Control terminals labeled "CONNECT DAMPER WIRES TO THIS SIDE".
 - a. Make sure wiring is made to the correct zone on the A2L Accessory / Zoning Control
- 7) Locate the refrigerant detection system for the HVAC unit. This will be a control board mounted inside air handler, furnace, modular blower or possibly a kit mounted outside the indoor unit. The control will have a 1/4" terminal on it marked ALARM or CTL-NO. Once identified, run a wire from the ALARM or CTL-NO terminal on the refrigerant detection system to the ALARM terminal on the A2L Accessory / Zoning Control (this is shown in the wiring diagram). A red wire is provided with the kit for this connection.
- 8) If the 1/4" terminal from step 7 was marked ALARM,

run an additional wire from the A2L Accessory / Zoning Control 1/4" terminal marked "TRANSFORMER COMMON FROM HVAC UNIT" to any common point inside the HVAC unit. A Blue wire is provided with the kit for this connection.

NOTE: This step is connecting to the HVAC system transformer, NOT the zoning control transformer.

They are separate transformers and need to be kept separate.

If the 1/4" terminal from step 7 was marked CTL-NO, see the wiring diagram labeled "ZONE Application with CTL-COM and CTL-NO Terminals". If multiple accessories are not being used, the kit contains additional wire that can be used to make the following connections.

- a. One wire needs to be run from the Zone system transformer R terminal to the CTL-COM 1/4" terminal inside HVAC system.
 - b. One additional wire needs to be run from the A2L Accessory / Zoning Control 1/4" terminal marked "TRANSFORMER COMMON FROM HVAC UNIT" to the common terminal of the Zone system transformer (NOT TO THE HVAC UNIT'S TRANSFORMER COMMON IN THIS CASE).
- 9) Locate the main 24VAC transformer power input to the Zone control. The wires in this terminal should be coming from the separate zone transformer.
 - 10) Per the wiring diagram, run two wires from the zone control 24VAC power input terminal to the A2L Accessory / Zoning Control terminals marked "ZONE POWER, ZONE-C, ZONE-R".

ZONE APPLICATION TEST

RUNNING THE SYSTEM TEST IS MANDATORY FOR ALL INSTALLATIONS. THE HVAC SYSTEM MUST NOT COMPLETE COMMISSIONING UNTIL THE INSTALLATION STEPS LISTED IN THIS MANUAL HAVE BEEN SUCCESSFULLY COMPLETED.

- 1) Apply power to the HVAC system. A green LED by the Zone Power terminals will turn ON indicating zone transformer power has been applied.
- 2) Confirm all zone dampers are closed
 - a. Note that some zone controls default on all dampers to the OPEN position when the system is idle and there is no call for cooling, heating, or fan. For these systems, select any single zone and, for that zone only, give the unit a fan call (if a fan only call is not available, provide a cooling or heating call to that one zone). Leave the other zones off.
 - b. Doing this will ensure the one zone calling remains open while the zone control closes dampers to the remaining zones.
- 3) Disconnect the unit from the power line and locate the R-32 sensor cable and the refrigerant leak detection system control board that it is connected to.

 WARNING
<p>HIGH VOLTAGE DISCONNECT ALL POWER BEFORE SERVICING OR INSTALLING THIS UNIT. MULTIPLE POWER SOURCES MAY BE PRESENT. FAILURE TO DO SO MAY CAUSE PROPERTY DAMAGE, PERSONAL INJURY OR DEATH.</p> 

This control board will be mounted inside an air handler, furnace, modular blower or possibly a kit mounted outside the indoor unit. Once located, disconnect the R-32 Sensor from the refrigerant leak detection system control board. After disconnecting the R-32 Sensor, assemble the HVAC unit back as per the final installation setup, followed by reconnecting the power to the HVAC unit. Doing this will energize the Alarm or CTL-NO terminal of the refrigerant leak detection system within 30 seconds.

- 4) Confirm the red LED next to the 1/4" ALARM terminal on the A2L Accessory / Zoning Control board is ON. This confirms the HVAC system has been properly wired to the control board.
 - a. NOTE: the green LED will remain on. This LED indicates zone transformer power has been applied to the control.
- 5) Confirm all zones fully open the dampers and remain open. Disconnect the unit from the power line and reconnect the R-32 sensor to its original location from step 3. After reassembling the HVAC unit, reconnect the power line. The Red LED on the A2L Accessory / Zoning Control board will have turned OFF and all the zone dampers will return to the original state they were in after step 1.
- 6) This completes the zoning test of the A2L Accessory / Zoning Control board.

ACCESSORY APPLICATION
WIRING FOR ACCESSORY APPLICATION

NOTE: The A2L Accessory / Zoning Control is designed to remove main power from an installed accessory to ensure the device is off in the event of a refrigerant leak. Accessory control wires (from a thermostat, humidistat, air circulation timer, etc.) are to be wired separately. White and Black wires are provided with the kit to make the appropriate connections.

NOTE: A2L Accessory / Zoning Control will support 2 accessories. If more than two are used, an additional A2L Accessory / Zoning Control will be needed.

- 1) Connect the two power wires from the accessory device to the A2L Accessory / Zoning Control 1/4" terminals labeled "CONNECT ACCESSORY TO THIS SIDE". White and Black wires are provided with the kit to make the appropriate connections.
 - a. Two terminals are marked ACCESSORY 1 and two other terminals are marked ACCESSORY 2. note which side each accessory is connected.

- 2) Connect power wire, from the Accessory's main power source to the A2L Accessory / Zoning Control 1/4" terminals labeled "CONNECT ACCESSORY POWER". White and Black wires are provided with the kit to make the appropriate connections.
 - a. Two terminals are marked ACCESSORY 1 and two other terminals are marked ACCESSORY 2.
 - b. Make sure to connect power to the correct terminals associated with the installed accessory.
 - c. 120VAC or 24VAC power can be applied
- 3) Locate the refrigerant detection system for the HVAC unit. This will be a control board mounted inside or possibly a kit mounted outside the unit. The control will have a 1/4" terminal on it marked ALARM or CTL-NO. Once Identified, run a wire from the ALARM or CTL-NO terminal on the refrigerant leak detection system to the ALARM terminal on the A2L Accessory / Zoning Control (this is shown in the wiring diagram). A red wire is provided with the kit for this connection.
- 4) If the 1/4" terminal from step 7 was marked ALARM, run an additional wire from the A2L Accessory / Zoning Control 1/4" terminal marked "TRANSFORMER COMMON FROM HVAC SYSTEM" to any common point inside the HVAC unit. A blue wire is provided with the kit for this connection. If the 1/4" terminal from step 7 was marked CTL-NO, see the wiring diagrams labeled "Accessory Application with CTL-COM and CTL-NO Terminals". Different wiring methods are shown if the accessory power source is 24VAC or if it is 120VAC. Make sure to use the correct wiring for the power source being used.

ACCESSORY APPLICATION TEST

RUNNING THE SYSTEM TEST IS MANDATORY FOR ALL INSTALLATIONS. THE HVAC SYSTEM MUST NOT COMPLETE COMMISSIONING UNTIL THE INSTALLATION STEPS LISTED IN THIS MANUAL HAVE BEEN SUCCESSFULLY COMPLETED.

- 1) Turn power on to HVAC system and accessory devices. Confirm accessory devices are appropriately powered.
- 2) Green LEDs next to Accessory 1 and Accessory 2 terminals will be ON if power is being applied to those terminals. The LED will only be energized if an Accessory is installed and powered.
- 3) Disconnect the unit from the power line and locate the R-32 sensor cable and the refrigerant leak detection system control board that it is connected to.

 WARNING
<p>HIGH VOLTAGE DISCONNECT ALL POWER BEFORE SERVICING OR INSTALLING THIS UNIT. MULTIPLE POWER SOURCES MAY BE PRESENT. FAILURE TO DO SO MAY CAUSE PROPERTY DAMAGE, PERSONAL INJURY OR DEATH.</p> 

This control board will be mounted inside an air handler, furnace, modular blower or possibly a kit mounted outside the indoor unit. Once located, disconnect the R-32 Sensor from the refrigerant leak detection system control board. After disconnecting the R-32 Sensor, assemble the HVAC unit back as per the final installation setup, followed by reconnecting the power to the HVAC unit. Doing this will energize the Alarm or CTL-NO terminal of the refrigerant leak detection system within 30 seconds.

- 4) Confirm the red LED next to the ¼" ALARM terminal on the A2L Accessory / Zoning Control is ON. This confirms the HVAC system has been properly wired to the control.
- 5) Confirm the green LEDs next to Accessory 1 and Accessory 2 terminals are both OFF (no power is being applied to the accessories).
- 6) Confirm the installed accessories are off.
- 7) Disconnect the unit from the power line and reconnect the R-32 sensor to its original location from step 3. After reassembling the HVAC unit, reconnect the power line. The Red LED on the A2L Accessory / Zoning Control board will have turned OFF and all the accessories will return to the original state they were in after step 1.
- 8) Confirm the Accessories have turned back on.
- 9) This completes the accessory test of the R-32

A2L ACCESSORY / ZONING CONTROL

Applications with more than 3 zones or more than 2 accessories will require a second A2L Accessory / Zoning Control. Using the wiring diagram provided, jump the Alarm and HVAC Common terminals to the second control and wire zone dampers / accessories as shown. Note: power from the zoning transformer must also be applied to the second A2L Accessory / Zoning Control (shown in wiring diagram). All test steps as detailed in this manual for zone and accessory installs will also apply to systems using more than one A2L Accessory / Zoning Control.

PAGE LEFT INTENTIONALLY BLANK

PAGE LEFT INTENTIONALLY BLANK

PAGE LEFT INTENTIONALLY BLANK

CUSTOMER FEEDBACK

We are very interested in all product comments.

Please fill out the feedback form on one of the following links:

Daikin Products: (<https://daikincomfort.com/contact-us>)

Goodman® Brand Products: (<http://www.goodmanmfg.com/about/contact-us>).

Amana® Brand Products: (<http://www.amana-hac.com/about-us/contact-us>).

You can also scan the QR code on the right for the product brand you purchased to be directed to the feedback page.



DAIKIN



GOODMAN® BRAND



AMANA® BRAND

19001 Kermier Rd., Waller, TX 77484

www.daikincomfort.com • www.goodmanmfg.com • www.amana-hac.com

© 2024 Daikin Comfort Technologies Manufacturing, L.P.

Amana is a registered trademark of Maytag Corporation or its related companies and is used under license. All rights reserved.