

Installation, Operation and Maintenance Manual

Please read and save these instructions for future reference. Read carefully before attempting to assemble, install, operate or maintain the product described. Protect yourself and others by observing all safety information. Failure to comply with instructions could result in personal injury and/or property damage!



General Information

This instruction manual provides installation, operating, maintenance, and parts information for the HOA Controller.

WARNING

Improper installation, adjustment, alterations, service or maintenance can cause injury and property damage, as well as possible voiding of factory warranty. No person may install, operate, or maintain the HOA Controller without first being fully trained and qualified in the installation, operation and maintenance, and carefully reading and understanding the contents of this manual. If you have any questions about these instructions, contact your local representative.

HOA Controller Features

- Simple installation & setup
- 100 ~ 277Vac, 50/60Hz Input Voltage
- Fireman's Override - Takes precedence over all operations via Voltage Input
- OLED display with user-friendly keypad interface
- Hand/Off/Auto-Local/Auto Remote operations.
- On-Board Speed Control
- Run Status Relay Output
- Auxiliary Contact Output

Table of Contents

General Information	1
➤ HOA Controller Features	1
Installation	2
➤ General Safety Information	2
➤ Control Components	2
➤ Mounting and Wiring	3
HOA Wiring Diagram/Specifications	4
➤ Operation	4
➤ Troubleshooting Guide	6
Our Commitment	7

Installation

General Safety Information

Only qualified personnel should install this product. Personnel should have a clear understanding of these instructions and should be aware of general safety precautions. Improper installation can result in electric shock, possible injury due to coming in contact with moving parts, as well as other potential hazards. If more information is needed, contact a licensed professional engineer before moving forward.

1. Follow all local electrical and safety codes, as well as the National Electrical Code (NEC) and the National Fire Protection Agency (NFPA), where applicable. Follow the Canadian Electrical Code (CEC) and ULC-S650 if installing this product in Canada.
2. Verify that the power source is compatible with the equipment

Receiving

Upon receiving the product, check to ensure all items are accounted for by referencing the delivery receipt or packing list. Inspect each crate or carton for shipping damage before accepting delivery. Alert the carrier of any damage detected. The customer will note damage (or shortage of items) on the delivery receipt and all copies of the bill of lading which is countersigned by the delivering carrier. If damaged, immediately contact your local representative. Any physical damage to the unit after acceptance is not the responsibility of the manufacturer.

Unpacking

Verify that all required parts and the correct quantity of each item have been received. If any items are missing, report shortages to your local representative to arrange for obtaining missing parts. Sometimes it is not possible that all items for the unit be shipped together due to availability of transportation and truck space. Confirmation of shipment(s) must be limited to only items on the bill of lading.

Storage

Controls are protected against damage during shipment. If the control cannot be installed and operated immediately, precautions need to be taken to prevent deterioration of the control during storage. The user assumes responsibility of the control and accessories while in storage. The manufacturer will not be responsible for damage during storage. These suggestions are provided solely as a convenience to the user.

Indoor

The ideal environment for the storage of controls and accessories is indoors, above grade, in a low humidity atmosphere that is sealed to prevent the entry of blowing dust, rain or snow. Care must be taken to protect controls and accessories from dirt, moisture, and extreme temperature during storage.

NOTE: Improper storage which results in damage to the product will void the warranty.

Control Components

Verify that all of the following parts and hardware have been received prior to beginning installation. Contact your local representative or the manufacturer if replacement parts are required.

NOTE: Additional parts (provided by others) may be required to complete the control installation, including additional wiring and hardware for mounting the control to the building structure.

NOTE: See following page for diagram of provided mounting kit and control components.

HOA Controller Mounting

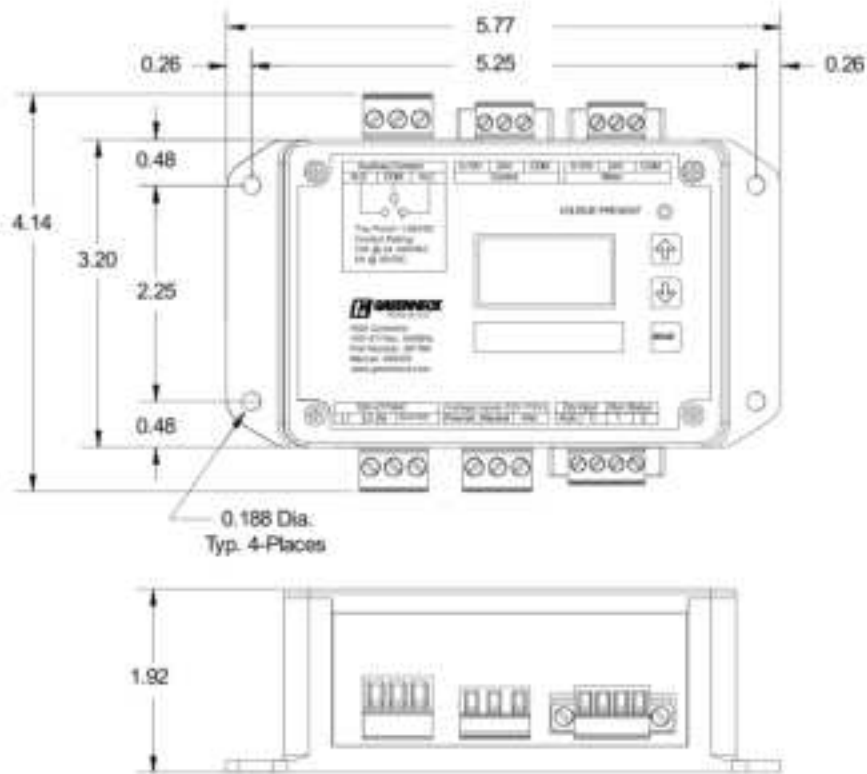

HOA Wiring

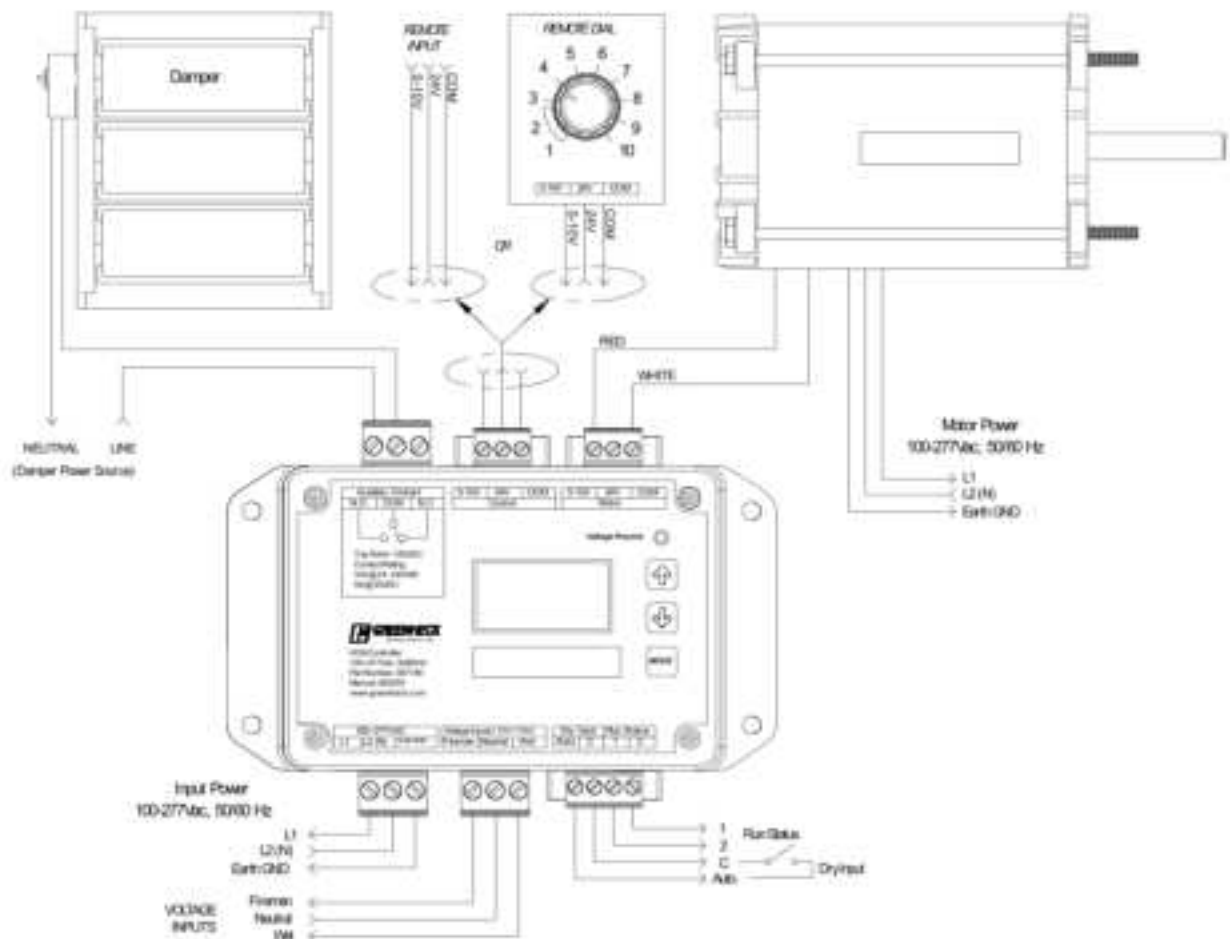

HOA Wiring Diagram/Specifications

Specifications:

Input Power: 100 ~ 277Vac 50/60Hz

Fireman's Voltage Input: (12Vac ~ 115Vac)

Voltage Input Auto Local/Auto Remote: (12Vac ~ 115Vac)

Dry Input Auto Local/Auto Remote: provide contact closure between Auto and C.

Run Status: Closes when $\geq 2.0V$ motor speed.

Auxiliary Contact: The N.O./N.C. changes state at 1.85Vdc. Contact rated for 10A at 24-240Vac, 5A at 30Vdc.

Remote Dial or Control Input: 0 - 10V input. +24V available for source powering Remote Dial or Sensor.

Operation

IMPORTANT: Ensure that all wiring is complete before applying power to the HOA controller.

Initial Setup

1. Apply power to the HOA controller. The controller will display "Press Mode V1.00" and the Voltage Present LED will illuminate Green as shown to the right.
2. Press MODE button will activate **HAND Mode** Operation. This will allow the end user or service member to control motor speed without enabling the motor via Voltage or Dry Inputs. Factory set to 5.00V. To change speed, Press the Up arrow to Increase or Down arrow to Decrease Motor Speed. New speed setting will be saved when Mode button is pressed.
3. Pressing MODE button again will activate **OFF Mode**. This will disable the motor. **NOTE:** Unless a Fireman's Input is activated via Voltage Input.
4. Pressing MODE button again will activate **Auto Local**: Controls motor speed using HOA Up/Down buttons along with either Voltage Input (12V ~ 115V) between Auto and COM on Voltage Input terminal block or a Dry Contact Closure between Auto and COM on the Dry Input Terminal Block to enable it.

387186 HOA Controller
Wiring Diagram

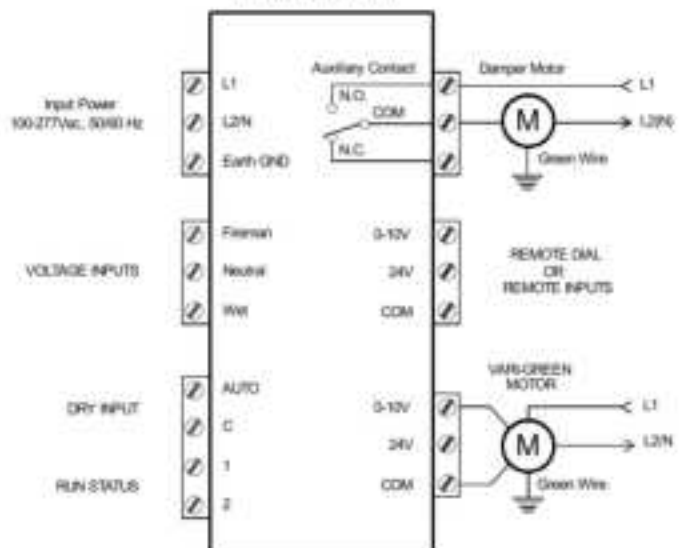

- Pressing MODE button again will activate **Auto Remote**: Will receive a 0-10V signal from the Control Input Terminal Block and the OLED will display current reading. Either Voltage Input (12V ~ 115V) between Auto and COM on Voltage Input terminal block or a Dry Contact Closure between Auto and COM on the Dry Input Terminal Block is required to enable it.



- Fireman's Override** – Apply a Voltage Input in the range of 12V ~ 115V between Auto and COM on Voltage Input terminal block to enable. The Green Voltage Present LED will flash when HOA Controller is in Fireman's Mode. **NOTE:** Fireman's Override takes precedence over all Modes and is Factory set to 10.0V

Fireman's Set Point: Press and hold Up and Down arrows simultaneously until Fireman's setpoint is activated. Press Up or Down arrow for the desired setting. Press mode to Exit and new setting will be saved.



- Software Version:** Depress the Up arrow and Mode button simultaneously until the software version displayed. It will remain on for three seconds and return to the last mode of operation.
- Factory Reset:** Depress the Down arrow and Mode button simultaneously until the controller displays "Press Mode V1.00"



HOA Troubleshooting

387186 HOA Troubleshooting Guide		
Symptoms	Potential Issue	Fix
No OLED Display or Voltage Present LED Illuminated	<ul style="list-style-type: none"> ✓ Loss of Input Power 	<ul style="list-style-type: none"> ✓ Check Wiring ✓ Validate correct Input Power to Terminal Block
Voltage Present LED Illuminated Green, No OLED Display	<ul style="list-style-type: none"> ✓ Defective OLED Display ✓ No +24V 	<ul style="list-style-type: none"> ✓ Cycle Power ✓ Using a Multimeter, Validate +24V at Motor Out Terminal Block. ✓ Contact MFG.
Motor does not turn ON when in Hand Mode	<ul style="list-style-type: none"> ✓ Incorrect wiring ✓ No Motor Input Power ✓ Faulty Motor 	<ul style="list-style-type: none"> ✓ Validate Motor Wiring ✓ Validate Motor input voltage ✓ Validate +24V at Motor Terminal Block ✓ Validate 0-10V Motor command Voltage at Motor Terminal Block. ✓ Motor command voltage must be >than 2.00V ✓ Replace motor.
Motor does not turn ON when in Auto Local Mode	<ul style="list-style-type: none"> ✓ Incorrect wiring ✓ No Motor Input Power ✓ No Wet Input detected to enable motor output. ✓ No Dry Input detected to enable motor output. ✓ Motor command must be > than 2.00V 	<ul style="list-style-type: none"> ✓ Validate Wiring to Wet Input Terminal Block. ✓ Validate 12V – 115V to Wet Input Terminal Block. ✓ Validate Wiring to Dry Input Terminal Block. ✓ Validate contact closure to dry Input Terminal Block. ✓ Validate 0-10V motor speed command must be > than 2.00V ✓ Validate Motor input voltage
Motor does not turn ON when in Auto Remote Mode	<ul style="list-style-type: none"> ✓ Incorrect wiring ✓ No Motor Input Power ✓ No Wet Input detected to enable motor output. ✓ No Dry Input detected to enable motor output. ✓ No Remote Dial or Control Input. command must be > than 2.00V 	<ul style="list-style-type: none"> ✓ Validate Wiring to Wet Input Terminal Block. ✓ Validate 12V – 115V to Wet Input Terminal Block. ✓ Validate Wiring to Dry Input Terminal Block. ✓ Validate contact closure to dry Input Terminal Block. ✓ Validate 0-10V at control input Terminal Block. Motor command must be > than 2.00V ✓ Validate 0-10V speed command at Motor Terminal Block. ✓ Validate Motor input voltage
No Fireman's Output	<ul style="list-style-type: none"> ✓ Incorrect wiring ✓ No Motor Input Power ✓ No Voltage Input detected to enable motor output. 	<ul style="list-style-type: none"> ✓ Validate Wiring to Voltage Input Terminal Block for Fireman's input ✓ Validate 12V – 115V to Voltage Input Terminal Block for Fireman's Input. ✓ Validate Motor Wiring at Motor Output Terminal Block. ✓ Validate motor output terminal block is as programmed
No Run Status	<ul style="list-style-type: none"> ✓ Incorrect wiring ✓ Motor command must be \geq than 2.00V 	<ul style="list-style-type: none"> ✓ Validate Wiring. ✓ Validate Motor speed voltage \geq than 2.00V at Motor Output Terminal Block

Our Commitment

As a result of our commitment to continuous improvement, Greenheck reserves the right to change specifications without notice.

Product warranties can be found online at Greenheck.com, either on the specific product page or in the literature section of the website at Greenheck.com/Resources/Library/Literature.

AMCA Publication 410-96, Safety Practices for Users and Installers of Industrial and Commercial Fans, provides additional safety information. This publication can be obtained from AMCA International, Inc. at www.amca.org.



Phone: 715.359.6171 • Fax: 715.355.2399 • Parts: 800.355.5354 • E-mail: gfcinfo@greenheck.com • Website: www.greenheck.com