

USER MANUAL

Objective.

Dear user:

Thank you for your trust our company, choose a good convenience, security, economy of printer, we look forward to quality products and services for your work and life to add fun.

Reading and following the contents of this manual before first use will help you better understand that using a Swiss color printer will keep your new printer running well for future use, always have the best print results, and the more you know about your printer, the more stable you can use your printer.

If you find some problems in the process of use, please contact color service personnel as soon as possible for repair, color service personnel will provide you with excellent after-sales service, please be sure to complete the maintenance work in accordance with the maintenance provisions in this manual on schedule.

This manual provides information on all types of printers of this type, and the instructions in this manual may differ from the actual configuration of the printer you purchased, depending on the printer you actually receive.

This manual is part of the printer and, if sold or loaned out, please give this manual to the owner.

All contents of this manual are the latest content at the time of publication, and now there will be no further notice of the changes,

Have a good life.

June 2023.

The cover and content of this manual are for reference only, specifically for the real machine.

,



Model	6090
Machine size. (MM)	L:1400
	W:1180
	H:720
The size of the platform. (MM)	600*900
Voltage requirements.	50/60HZ 220V(±10%)≤3.5V 110V(±10%)≤7V
Operating environment requirements	20-28℃ (68-82°F) HR40-60%
Nozzle	XP600/i1600
Ink curing system	Air-cooled curing
X/Y/Z axis move	X Stepper motor, Y Stepper motor., Z DC motor
Print software	PrintEXP,
Print the file format	TIFF/JPG, DPI Recommended requirements. ≥300
Computer system requirements	Win7/8/10 62bit
Ink	YMCKWW/CMYKWW
The connection port	RJ45 The network cable interface



Model	ZZ1C/ZZ2C
Machine size. (MM)	L:880 W:900 H:650
The size of the platform. (MM)	325x600
Voltage requirements.	50/60HZ 220V(±10%) ≤3.5V 110V (±10%) ≤7V
Operating environment requirements	20-28°C (68-82°F) HR40-60%
Nozzle	XP600/i1600
Ink curing system	Air-cooled curing
X/Y/Z axis move	X Stepper motor, Y Stepper motor., Z DC motor
Print software	PrintEXP,
Print the file format	TIFF/JPG, DPI Recommended requirements. ≥300
Computer system requirements	Win7/8/10 62bit
Ink	YMCKWW/CMYKWW
The connection port	RJ45 The network cable interface



Model	ZZ2F
Machine size. (MM)	L:670 W:800 H:360
The size of the platform. (MM)	300*无限长
Voltage requirements.	50/60HZ 220V (±10%) ≤ 3.5V 110V (±10%) ≤ 7V
Operating environment requirements	20-28°C (68-82°F) HR40-60%
Nozzle	XP600/i1600
Ink curing system	Air-cooled curing
X/Y/Z axis move	X Stepper motor, Y Stepper motor., Z DC motor
Print software	PrintEXP,
Print the file format	TIFF/JPG, DPI Recommended requirements. ≥ 300
Computer system requirements	Win7/8/10 62bit
Ink	YMCKWW/CMYKWW
The connection port	RJ45 The network cable interface

Directory

Introduction

- The manual is introduced.
- Information tips.
- Introduction to the machine.
 - Machine parameters.
 - Features Overview .
 - The front view.
 - The rear view.
 - Keyboard.

Installation

- Place the instructions.
- Open the package.
- Handling guidance.
 - Error demonstration.
 - The correct demonstration.
- Remove the transport fixture.
- Fill the ink.
- Power up the printer.
 - fill up the cold water
- Software installation.
 - Change the IP connection to the PC .
- Drive the installation.
- Fill ink.
- Print nozzle detection.
- Color block printing.

Advanced printing.

- The print location changes.
 - White ink printing instructions.
- Fill only in colored places

- All filled.

- Spot color.

- Adjust the amount of inkjet inkjet.
- Color ink adjustment guidance.
- How to print white ink.
- Back and forth.
- Notes to be taken when printing.
- Print the varte oil.

Machine maintenance and troubleshooting.

- Equipment maintenance guidance.
 - Daily maintenance .
 - Weekly maintenance.
 - Monthly maintenance.
 - Holiday printer maintenance.
- Troubleshooting.
 - The software could not be opened.
 - Still disconnect, even if changed IP
 - Print picture blur, fly ink.
 - Clicking on the white ink setting shows unrecognized. Don't go to the dongle.
 - The printed picture comes with water. Print or line.
 - How to calibrate two-way printing.
 - How to calibrate the nozzle spacing.
 - The treatment method for incomplete nozzle detection.

The manual is introduced



警告

1. Do not install or use the appliance in areas where children may be near.
2. Do not cover the air vents of the appliance.
3. Wear protective gloves to protect your hands when maintaining the machine or touching ink.
4. Cover the UV cover during printing to prevent the body from being directly exposed by a UV light for a long time.



注意

5. Do not place the printer in an unstable or unstable place or where it can cause the printer to vibrate.
6. When lifting this product, make sure that the lift is in the position shown in the manual.
7. Do not install the printer in places where there is a lot of dust and smoke, or where the printer is prone to moisture.
8. When moving the appliance, do not tilt it forward and back to the left and right by more than 15 degrees.
9. This product is heavy and cannot be carried by one person.
10. Leave enough space for the back end of the printer for platform movement.
11. Avoid placing the printer in places where the temperature is very different and avoiding direct sunlight from the machine.
12. Do not place the printer in an uneven place to make sure that the printer is running horizontally.
13. Choose a secure location for the platform to place the printer.
14. Do not connect the printer with any broken power cords.
15. Accessories, ink used in the Company is not purchased in the Company resulting in damage to the printer, does not provide warranty service.
16. The ink used is not purchased by the Company without guaranteeing print quality.

17. Information tips.



警告

Ignoring this warning can be serious

Human injury, this statement step must be strictly observed.



注意

indicates that the events described herein must be strictly observed,

Failure to do so may damage your device.

*

Said. The device or function described is only available on certain models equipped, or depending on customer needs will vary, you

The printer purchased does not necessarily have to be equipped with.

Introduction

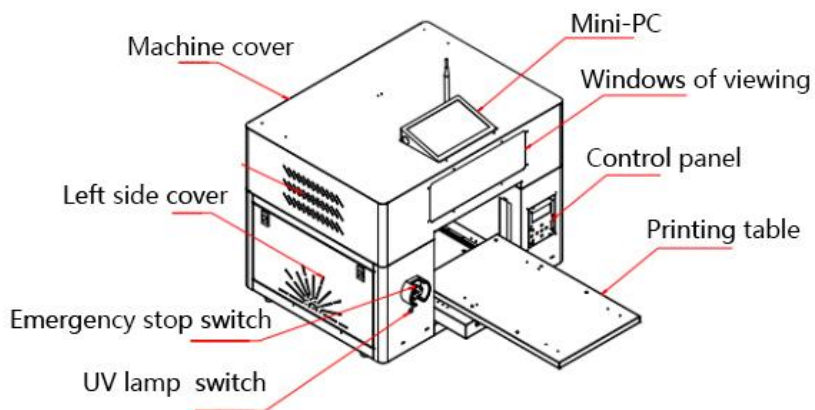
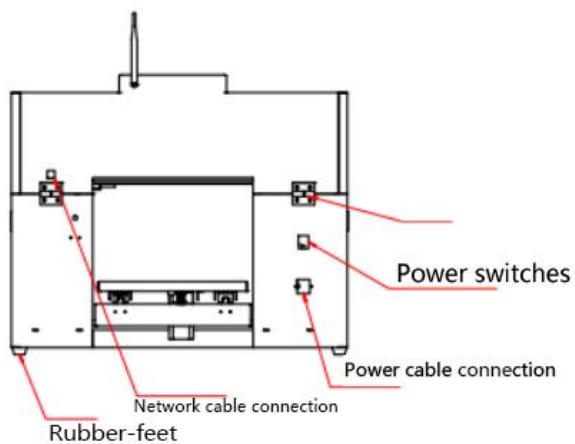

Keypads

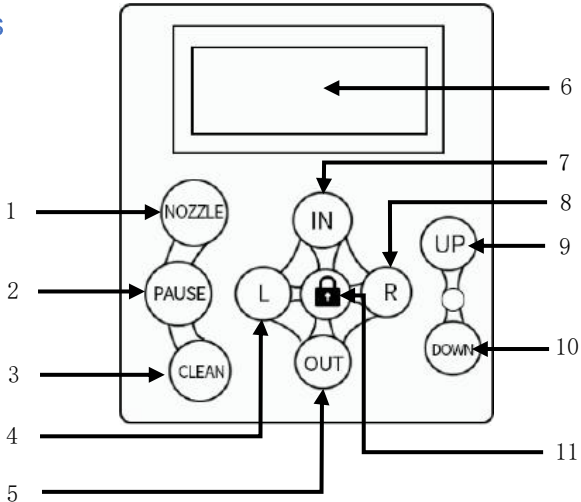

1. NOZZLE: press it once, printer will do a nozzle check and then it will back the home position automatically.
2. PAUSE: press it once, the printing task will be paused, press again ,it will continue to print
3. CLEAN: press it once the cleaning system will be running to clean the nozzle
4. L : control the printing carriage moving leftwards
5. OUT: control the platform moving frontwards
6. LED display
7. IN: control the platform moving backwards
8. R: control the printing carriage moving rightwards
9. UP: control the platform goes up
10. DOWN: control the platform goes down
11. LOCK: press it once, The carriage will back home position for keeping wet

Place the instructions

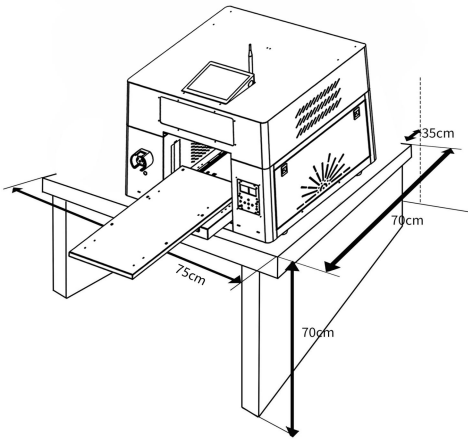

1. Install the printer on top of the stand, etc. The installation location is subject to the following conditions

(1) Dimensions should be the distance between the feet of the machine and the rubber feet of the machine.

(Subsequent models can be adjusted to the actual machine size)

(2) The height of the table is 70-80cm.

(3) ZZ1/ZZ2 front/back need to be vacated at least 30/35cm distance for platform movement

6060/6090 front/rear need to set aside 30/60cm distance for platform movement.

(Subsequent machines can be adjusted according to the actual platform length)

2. Place the printer in an environment that meets the following specifications.

(1) A flat position that is not vibrating and has enough space.

(2) Use only power outlets that meet the product's power requirements.

(3) Environmental conditions: 20-28C (68-82F) HR40-60%

(4) In order to maintain humidity, do not place the printer in direct sunlight, air outlet can be directly facing the place, etc.

Open the package

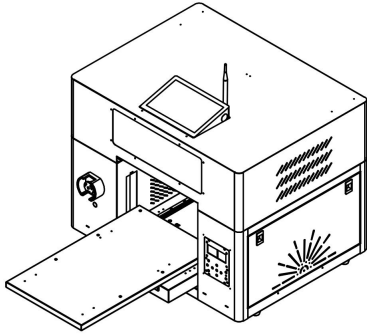

Printer

It will not be used during installation. ⚠, Always keep it safe so that parts can be replaced in future damage. .



Network Cable



cable



The power cord.



Screw driver



U disk



syringe

Handling guidance

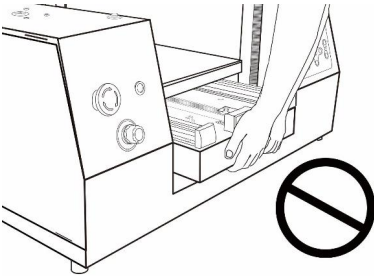

Error  注意 demonstration

When lifting the machine, do not lift the platform position, as shown in the figure on the left.

The correct demonstration

 注意

When lifting the machine, hold the area indicated in the picture, otherwise it may affect normal operation and printing.

A and B are required to lift at the same time or the printer will tilt and grip .

A minimum of 4 people is required to carry a large print machine.

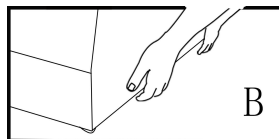
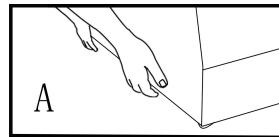
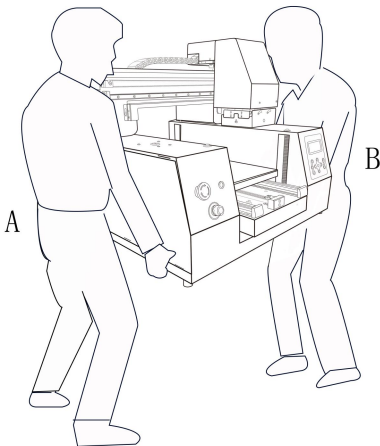

Removal of transport fixtures

2 Remove the retainer on the word car.



1. Remove the front tape and foam pads from the front

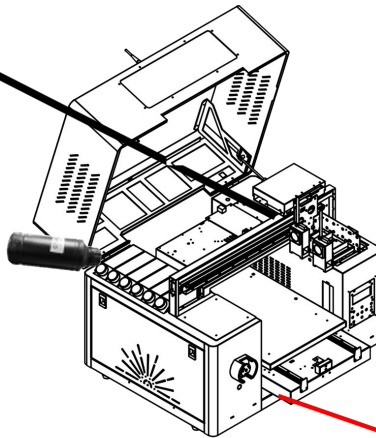
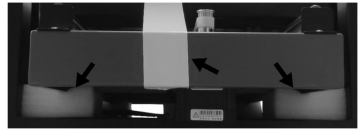

4. Fill the ink

3. Remove the tape and foam pad from the rear end.

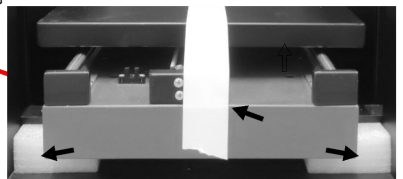

Power up the printer

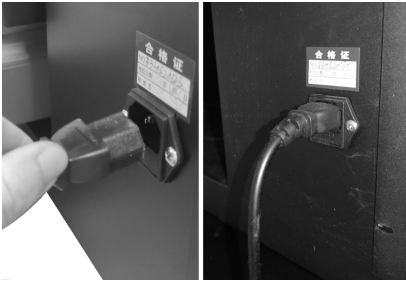

1. Attach the power



2. Internet access



3. Press the total switch



4. Turn the front switch right and the right-hand

Software installation

Turn off the antivirus software before installation (it is recommended to delete it, otherwise the software will not work when the computer is restarted).

It is best to install with a 64-bit system, and 32-bit may not be able to use the software properly.。



1. Find this zip and extract it



2. Find this software and double click to open it

change the IP connection to the PC

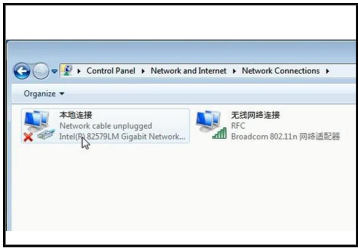

1. First, enter the network connection to find the icon of the wired network card, commonly called Ethernet.

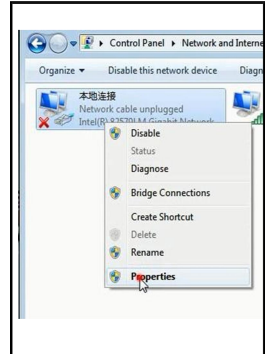

2. Right-click Ethernet, and left-click property

Access to network connections Location.

Control Panel\Network and Internet\Network and Sharing Center

Then click on Change Adapter Settings in the top left corner

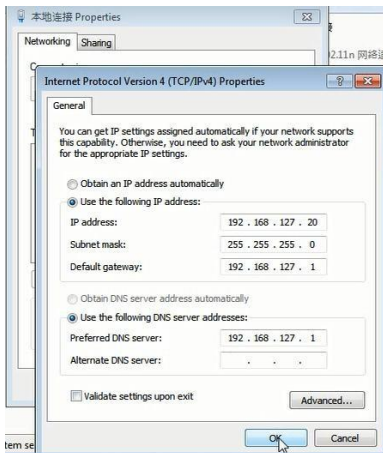

3. After selecting Internet Protocol Version 4 (TCP/IPv4), click the property.

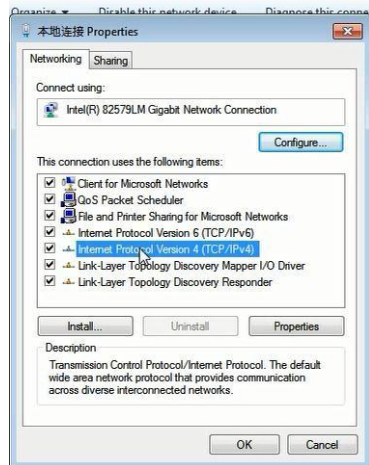

4. Select to use the IP address below, and then fill in the IP address written in the picture, and then click OK.

Print nozzle test lines

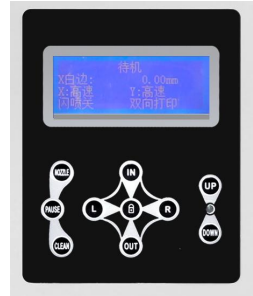

1. After placing a sheet of paper on the platform aligned with the lower right corner, adjust the height of the print item to 2-3mm

2 After adjusting the height, press the Nozzle button on the keypad.

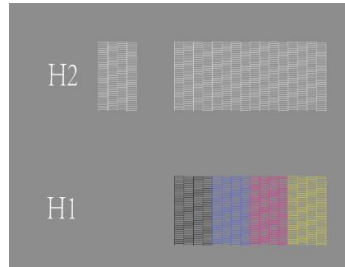
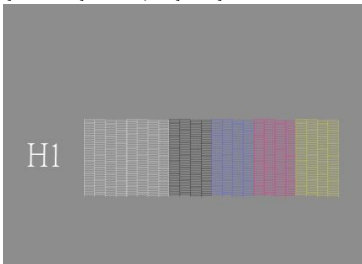

3. Single-head nozzle test lines results

4. Double-head nozzle test lines effect

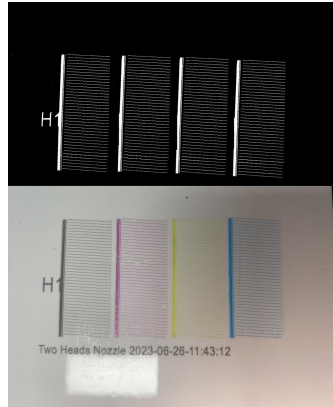

1. i1600 Single-head
nozzle test lines
results

2. i1600 Double-head
nozzle test lines
effect

1. If the nozzle detects a small number of missing lines (less than 10% of the lines) is normal and does not affect the print performance, print with confidence.
2. If the nozzle detects a large number of lines missing (greater than 10% of the line), please weak clear (can be used with strong clear) 2-3 times to solve, remember that no matter what the case, strong clear after the completion of the strong clear must be weak and clear again.
3. Please select the corresponding nozzle to check the comparison, single nozzle models are available (ZZ1), double nozzle models are available (ZZ2,) In order to improve the recognition of the nozzle detection in the picture, the above picture has been brightened, for reference only, please refer to the actual printing effect

Color block printing

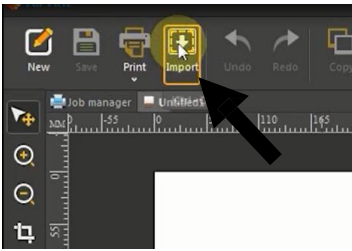

1. Open, Ripton software, click Import.

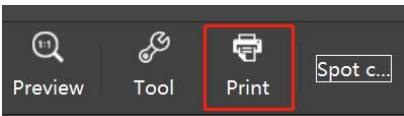

3. Click to print



5. Once the colour block has printed correctly you can continue to print the item you need to print.



2. Find the folder named Test Picture in the USB stick, double-click the color block and import

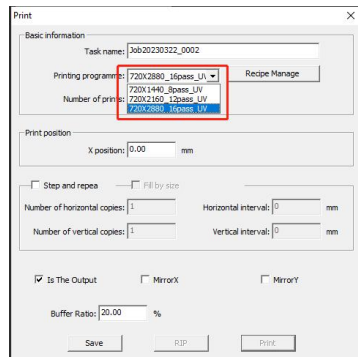

4. Select 16PASS and send as print



To avoid the necessary loss of print, please pay attention to the print height throughout the printing process to prevent damage to the printheads due to collisions.

The print location chan

1. Open the PrintEXP software and find the layout settings as shown below.



2. The X white margin adjusts the print position to the left and right, the Y white margin adjusts the print position to the front and back.

3. W is the height of the image H is the width of the image

Remember to press the Enter key after changing the number

4. You can see the print position with and without the changes.



White ink printing guide

1. Open the Ripprint software, then find "Spot Colour" and click on it.

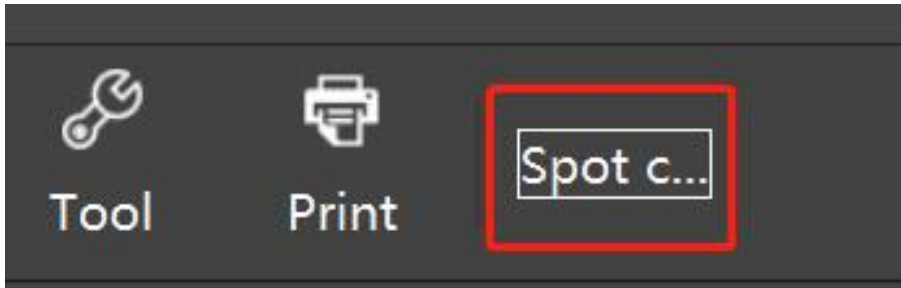

2. After the pop-up window, the data generation method of this line, this is to select the white ink printing method, generally speaking, such as the three options in the red circle above can print 99.9% of the picture, so just remember the function of these three options on the line.

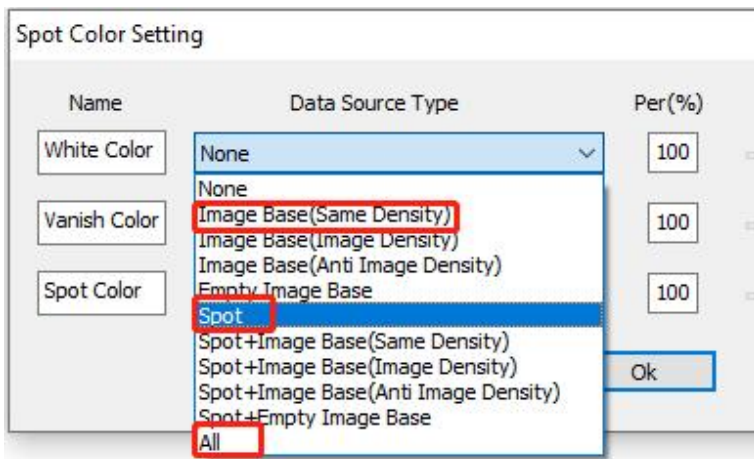

Fill only in colored places

Fill only where there is color on the picture: means only .

Where to color the picture (except the white part of the picture) will print a layer of white ink.

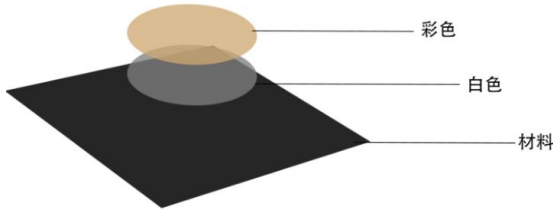

Print the structure diagram.

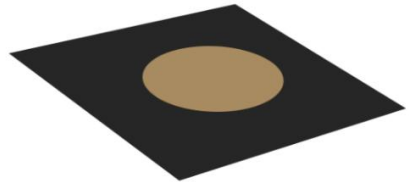

The print effect.

Fully filled

Full fill: this is the white ink that is printed depending on the size of your image.

Print as much white ink as the image is big.

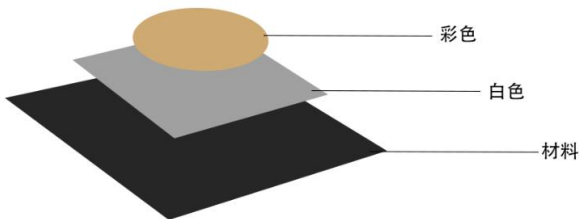

Print the structure diagram.

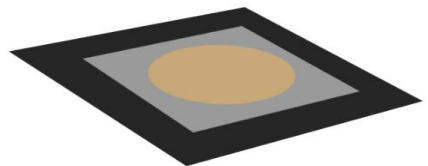

The print effect

Spot colour (requires a spot colour channel within photoshop)

This feature is: you can customise it yourself with PS software Where you need to print white, the preferred option is to use PS to give the image a spot colour, then the printer will print the spot colour for the area where it is done For more information on how to do this, please refer to the video on the USB stick.

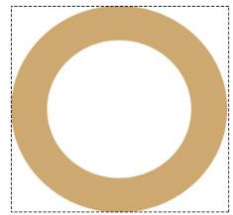

Original

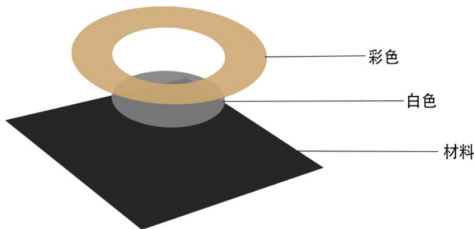

Print the structure

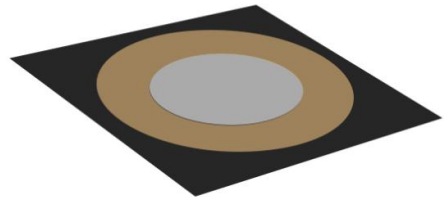

The print effect

Adjust the amount of inkjet inkjet

1. Open the Riprint software, then find "Spot Colors" and click on,

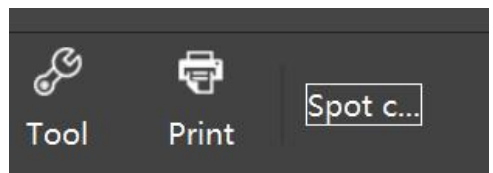
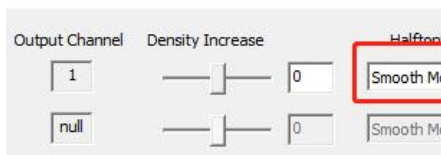

1. When the window pops up, you can thicken the white ink on the line corresponding to the white ink on the right.

Color ink adjustment guidance

- In the Riptest screen, then find Print
Click on it, then click on the 123 diagram in order to enter
Colour ink adjustment screen

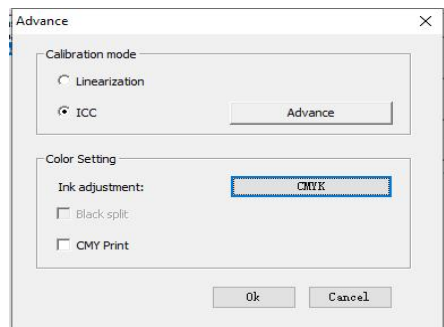
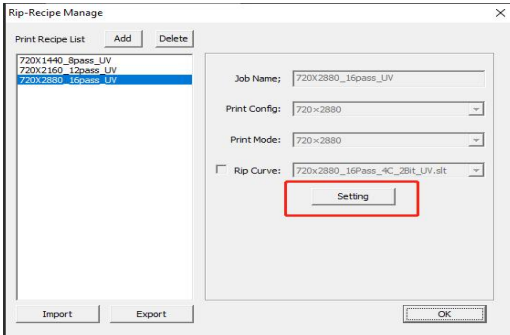
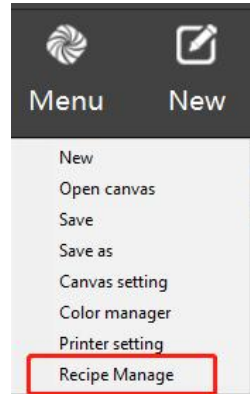

- The colour parameters can be changed on this side.
C is blue, M is red, Y is yellow, and
K is black.

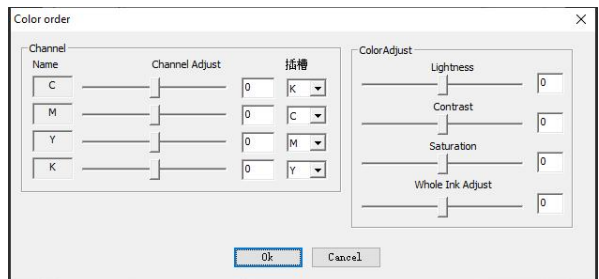

How to print only white ink

提示：使用此功能前请先了解机器如何打印白墨

This black background is for the white part to be lined up.

1. Tip: Know the machine before using this function.
how to print white ink



Original

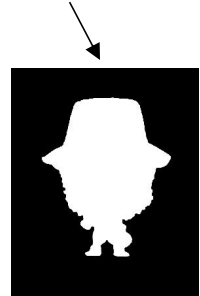

The print effect

2. Open the PrintEXP software and click on the settings at the top.

Then see the channel control selection for the advanced features on the right.

Only White be sure to put on the Riptent software.

White ink settings Turn on or you won't print anything, such as no.

Learn how to turn on first learn the White Ink Print Guide.

After you change the parameters, click Save the parameters.

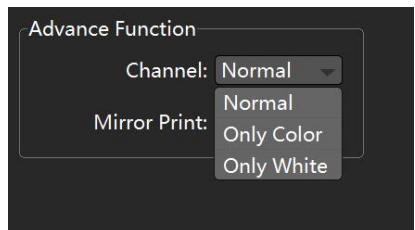
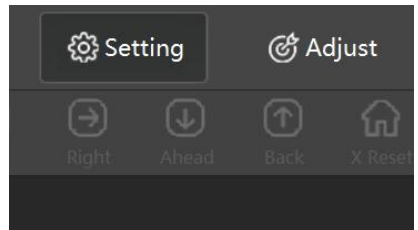

Back and forth

1. Back-to-back application scenarios are generally applications.

In transparent acrylic or glass such as transparent material

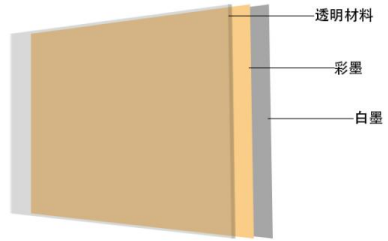

Watch the effect situ.

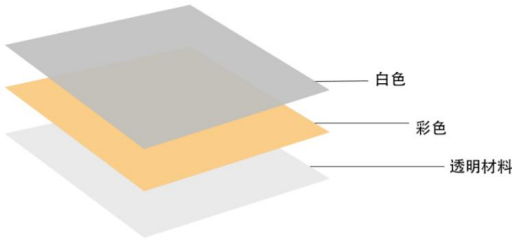

Print the structure diagram.

2. The printed sample is shown below



Transparent phone glass case



Transparent acrylic

3., First we need to generate a PRN file and open it. Riprint software, after importing the pictures you want to print, Click Print to send the way you need to choose to generate one. Prn file does not print, save the picture to the desktop, hit. Open The PrintEXP software, the direction of the paper to choose forward. Click save parameters after printing, and then click on the text in the upper left corner. button to find the suffix that was just saved to the desktop as PRN file, right-click immediately print, printer. will start to play back and look right

Follow the steps shown in the picture.

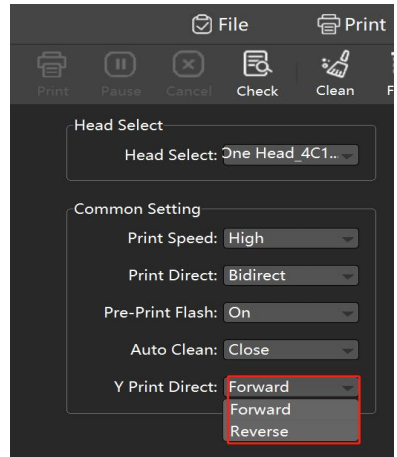

Printed varnish

Tip: Before using this function, please understand how the machine prints white ink

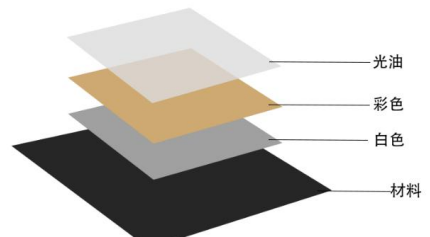

The principle of the three options on the right is the same as the introduction to how to print white ink introduced, so please refer to How to print white ink for the varnish printing procedure.

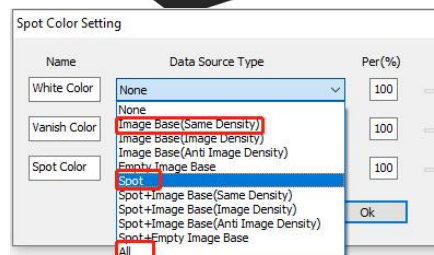

Print Notes

Material rules explained	Image specifications
<ol style="list-style-type: none"> 1. 1. Keep the surface of the print object clean . 2. 2. Objects of glass, metal, and some items with particularly smooth surfaces need to be coated before printing, otherwise the ink will not hang. 3. 3. Printed objects with a height difference of more than 3 mm cannot be printed. 4. 4. Printed textiles are recommended for clothes with a cotton content of 30% or more, below this value printing results will deteriorate . 5. 5. No silicone treatment on the garment, otherwise the ink will not adhere firmly to the garment 	<ol style="list-style-type: none"> 1. 1. High definition images improve print quality (300dpi or more)。 2. 2. Please change the size of the image in Photoshop to match the printed object before printing . 3. Photoshop can be used to adjust the brightness of the image to get a better print. 4. 4. If you need to print content that involves spot colours, please create them in Photoshop Photoshop. 5. 5. Supported image formats are TIFF or jpg
Printing requirements	Ink specifications
<ol style="list-style-type: none"> 1. Ensure that the print item is at the correct distance from the printhead before printing (2-3mm is the best distance to print) 2. Infra-red anti-collision system, unable to identify transparent objects . 3. The white ink setting must be switched on for printing on dark base colours, otherwise the colour will not appear. 	<ol style="list-style-type: none"> 1. 1. UV (hard) ink: mainly suitable for hard materials, such as metal, glass, acrylic, signage and other materials . 2. 2. UV (soft) ink: mainly suitable for soft materials, such as leather, leather covers, PVC, canvas, etc. . 3. 3. Textile inks: suitable for printing on textile fabrics (need to be used with ironing presses and other tools) 4. 4. Edible ink: suitable for printing all kinds of edible items, such as

- | | |
|--|--|
| <p>4. 4. Printed objects with a flat bottom can be placed directly on the platform, if the surface is smooth and easy to shift can be fixed with double-sided tape</p> <p>5. 5. paper-like (very thin, wrinkle-prone) materials, recommended for use with adsorption platforms .</p> <p>6. 6. For better results, use with automatic spray cans when spraying colour fixing agents .</p> | <p>biscuits, milk tea, sugar, etc.</p> |
|--|--|

This printer uses non-contact printing and can print on a wide range of materials such as mobile phone cases, leather, signs, mobile power, U-discs, KT boards, stone, wood, ceramics, crystal, acrylic, PVC, ABS, etc.

Equipment maintenance guidance



注意

To keep your printer working properly for a long time

Please observe the following for the maintenance of your printer

Daily maintenance (daily maintenance videos can be found on the USB stick)

1. Shake the ink, clean the nozzle and check the nozzle detection
2. Cleaning of blades, cleaning of ink pads.
3. Please wipe any residual ink from the printhead with a dust-free cloth, or a non-flaking paper towel, as shown in the picture on the right

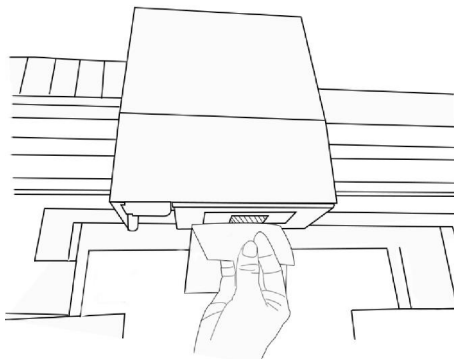

注意

(Wipe gently, remember not

to wipe brutally, otherwise it will cause damage to the nozzle)

4. When not printing, ensure that the word carriage is in a homing and moisturising state to prevent the ink from drying out and causing blockages, as shown in the diagram

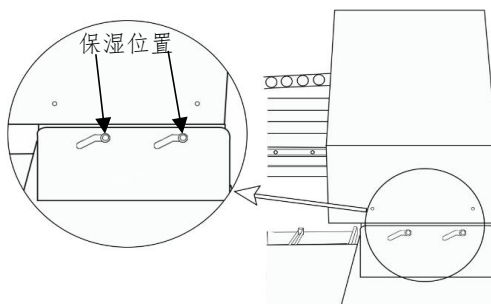

1. Weekly maintenance (weekly maintenance videos can be found on the USB stick)
2. Cleaning the grating strip
3. Cleaning the UV lamp table

Monthly maintenance (monthly maintenance videos can be found on the USB stick)

1. Regularly oil the printer guides to lubricate them to prevent blockage of the carriage movement.

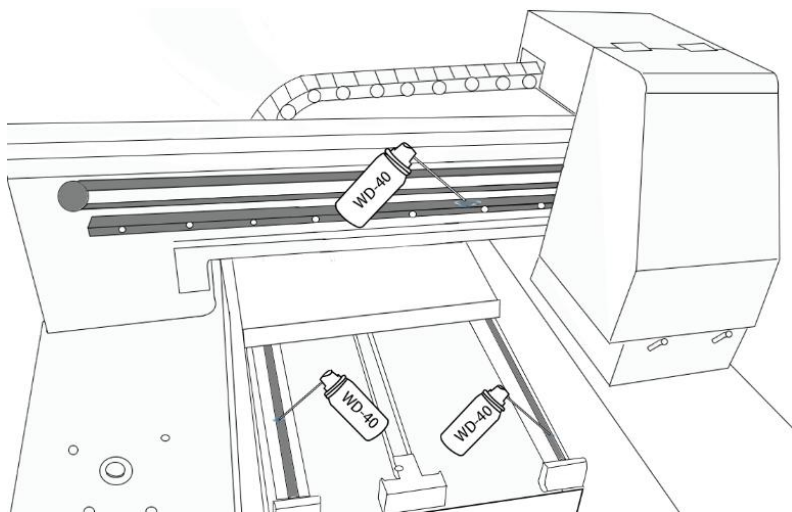

Holiday printer maintenance

	Operation steps	Video
Three days don't use a printer	1. Clean the printhead a few times and then print the printhead inspection	Can be found on a USB stick Name: Holiday Maintenance (3 days)

Machine maintenance and troubleshooting

	<ol style="list-style-type: none">2. Move the word carriage to the moistening position to switch off the machine3. Seal the vent on the ink bottle .	
No printer for a week or more	<ol style="list-style-type: none">1. Manual cleaning of the printheads and cleaning of the ink pump2. Move the word carriage to the moistening position to switch off the machine3. Sealing ink bottles	Can be found on the USB stick Name: Holiday Maintenance (7 days)



Because the printhead is relatively expensive, so the above operation must use the company's supplies, in the operation of any technical problems can consult the technical staff, due to different environments, different ways of operation caused by the nozzle blockage or damage to the company does not assume any responsibility. (The temperature of the environment where the UV flatbed printer is stored is kept above 10° C).

For the normal operation of the printer, please be sure to maintain the printer, if you have any questions, please consult the technical staff.

Troubleshooting

The software could not be opened

Showing error info or messy code as below picture shown, in this point proving your computer who don't having prerequisite framework.

Plug this silver flash disk and come in folder named common question solving file to find out "Microsoft C++" and open it to install the framework.

After succeeded install, please try to open the printing software again.

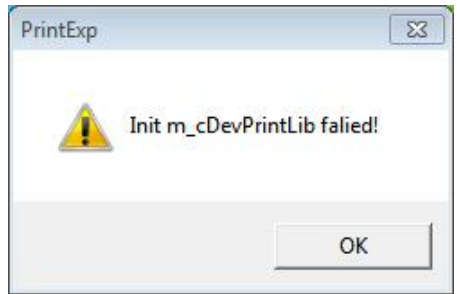

Still disconnect,even if changed IP

1. please make sure is the printer connecting computer by network ethernet cable as below shown

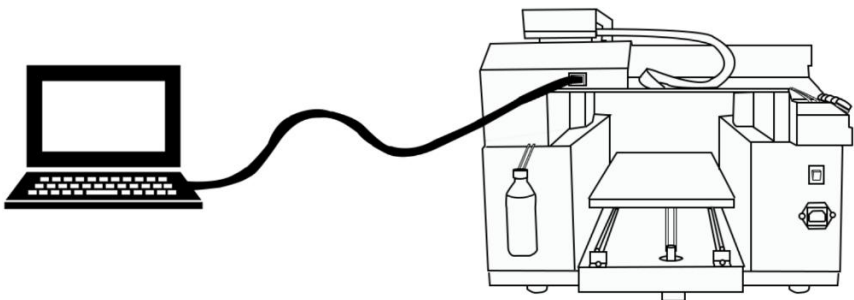

2. Please check if your printer is powered on, check methods such as the right

Machine maintenance and troubleshooting

image to see if the printer's display is lit, such as the display is off, prove that the printer is not turned on, please turn on the printer, such as make sure that the printer is turned on and still can not solve you

3. The printer who only can be recognized by gigabit card.so check your network card out if it is gigabit.

o



If you don't know how to open this window to check your computer's network card type, you can go to the video "How to check your network card type" in the FAQ document on your USB stick, or search for "How to check your network card type" on Baidu depending on your system."

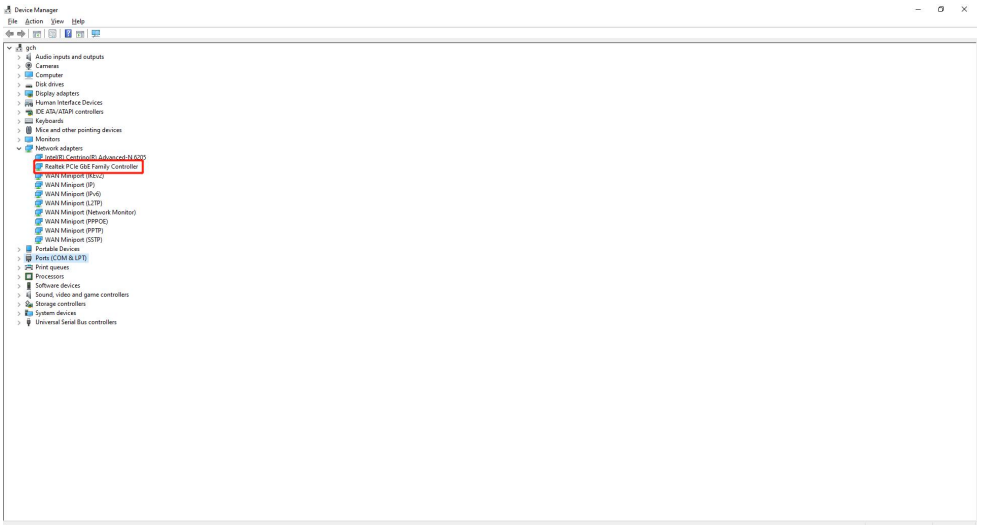

The GBE card proves that it is a Gigabit network card and can be connected to the printer properly

4. If your NIC is a 100 Gigabit NIC, you will need to purchase a Gigabit NIC adapter as shown in the picture.

Must be a gigabit NIC adapter



Printing blurred images with flying ink

1. As shown in the image below, the printed image does not look good



Correct distance



Distance is a bit far



Long distance

bad

2.
You
can

see

good

bad

So bad

above

there are three pictures, the quality of "good" "poor" "very poor" three effects of the picture, there is this difference depends mainly on the print distance (print distance is the distance between the printhead and (print distance is the distance between the printhead and the object to be printed), we the printhead of the best printing distance of 2-3mm, more than 3mm spray out of the ink will spread, resulting in the print effect as shown above "poor" and "very poor", so want to print a good picture effect The prerequisite must be a good printing distance, you can find in the U disk video: "how to adjust the printing distance", to the printer to adjust a good printing distance before printing, such as the inability to accurately control the distance, you can consult the technical staff.

The ink printed out is wet

1. Please check first if the UV lamp is switched on, if not, press the UV lamp switch button as shown in the picture.
2. If the UV lamp is flashing, the UV lamp is faulty.

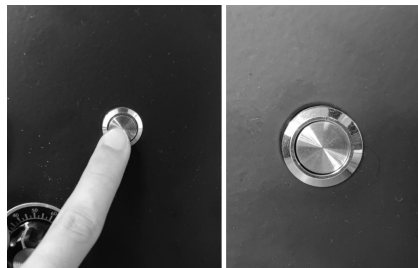

Please replace the UV lamp in time to solve the problem.

3. If you are still unable to solve the problem, please contact a technician to solve it.
4. Try increasing the power of the UV lamp through the UV lamp transformer to solve this problem

How to calibrate bi-directional printing

You can see that there is a double image on the picture, proving that bi-directional printing requires bi-directional calibration.

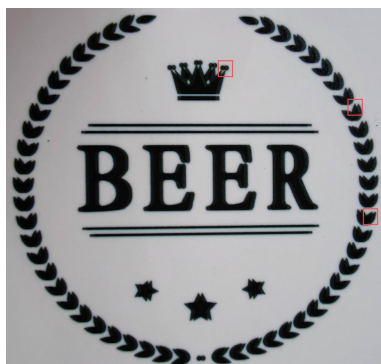

First open the PrintEXP software, then click on Calibration and click on it.

Then click on the two-way calibration on the left of the screen

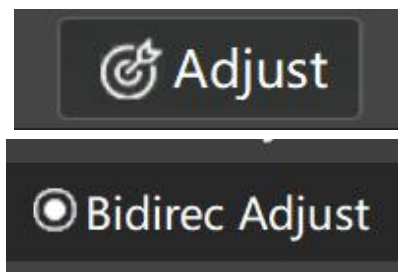

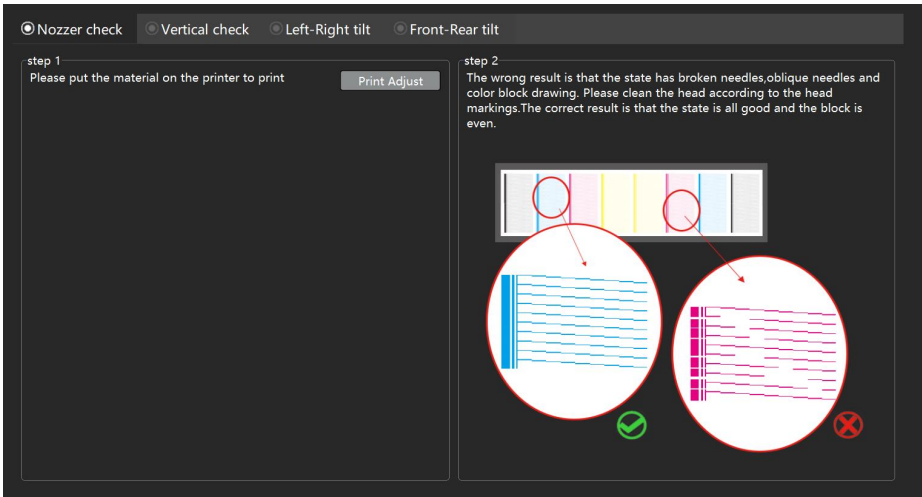

We first need to print out the calibration with 5 different single parameters to see which line is the thinnest. Remember that after changing the parameters for the

bi-directional offset values you need to click on Save Parameters

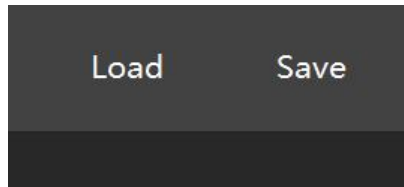

Then find the two-way calibration line of the test image on the USB stick and drag it into the Riprint software to start printing.

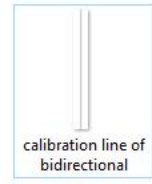

Use the values of 20 the bidirectional offset value 15 " " " 0" to " 5" to print 5 pictures, follow the figure below, and then select the thinnest two lines, the example 10" 5" and " 10" 10 are the thinnest of the five lines, so the next step is to print out the 6-9 value lines, Then select the thinnest line and save it

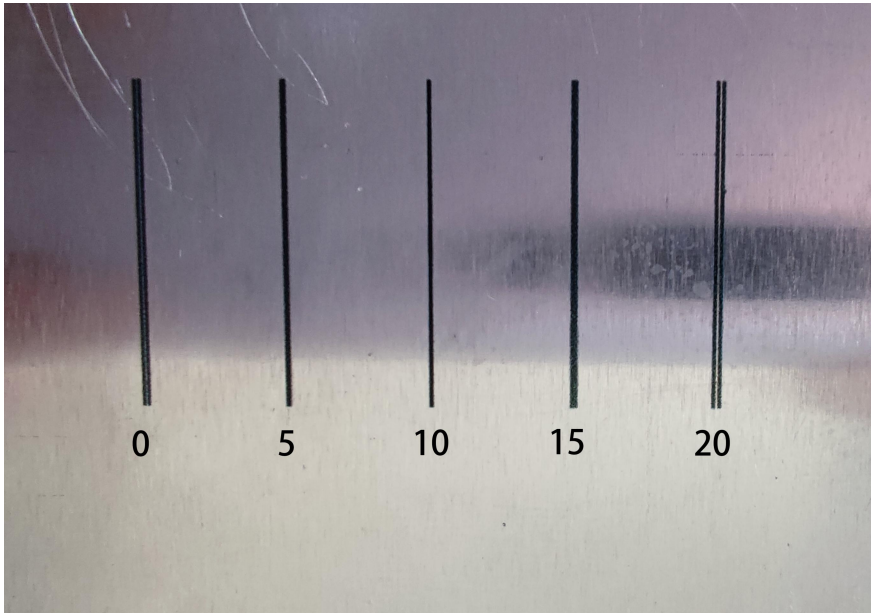

How to calibrate the nozzle spacing

You can see the right image of the white color misalignment, white ink and color ink printing position of about 1-2mm deviation, this time we need to double head for the print position calibration

In the setting, we can only change the white ink print position, so we have to use the color position.

If white is to the right, we need to move white a little to the left

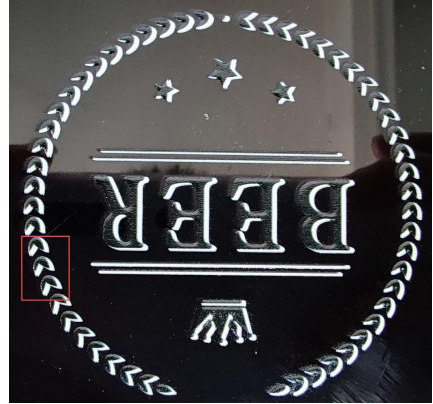

First open the PrintEXP software, then find the calibration point on above to go in, and then click on the nozzle spacing on the left side of the interface.



⊙ Nozzer check
⊙ Vertical check
⊙ Left-Right tilt
⊙ Front-Rear tilt

step 1

Please put the material on the printer to print

Print Adjust

step 2

The wrong result is that the splicing is offset. The splicing position is offset to the left to adjust the upper end of the head to the right or the lower end to the left; the splicing position is offset to the right to adjust the upper end of the head Adjust left or adjust the bottom to the right. The correct result is the alignment of the vertical stitching.

The treatment method for incomplete nozzle detection

If the nozzle detection line can not be hit out (missing line less than 10% of the whole is acceptable) we need to re-print before this problem, generally this problem, more cleaning even if can be solved, if the problem can not be resolved the part is generally "ink sac" "ink pad" "ink tube" "line" "spray head".

Type	The site of the problem	Chance of
One color is very poor	The sac is broken.	50%
Several colors are poor	The nozzle is blocked.	60%
One color is completely lost	The nozzle is blocked.	50%
Only a little ink out	Adjust the position of the ink sac.	60%

You can solve most of the problems that occur with poor nozzle detection based on video. (Video can be found on a USB stick).

1. How to replace the row of wires
2. How to replace the ink capsule
3. How to replace the ink pad
4. How to replace the printhead
5. How to flush the printhead

If you have any questions about the operation process, you can consult a technician for operation.

1. Setup the photo on a white ink output printing

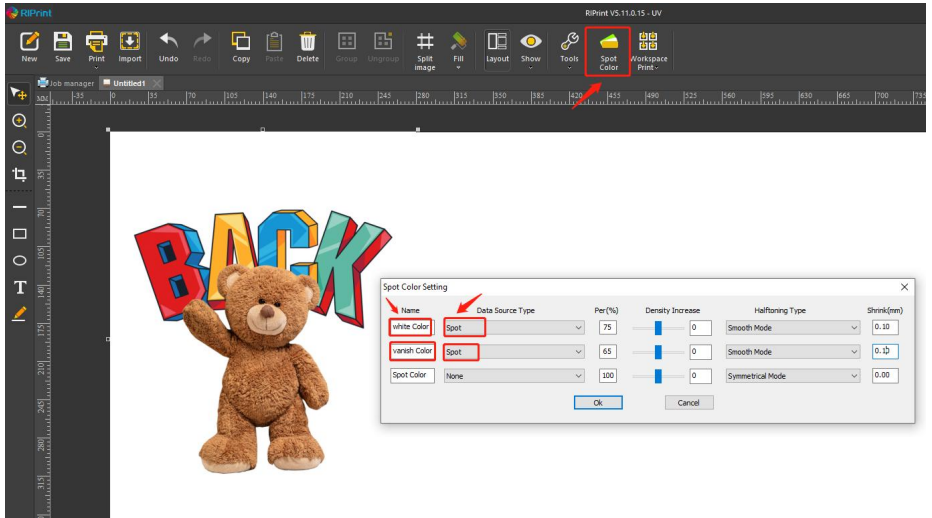

2. A film fixed on the platform, tear off the above
B film, printed on the A film

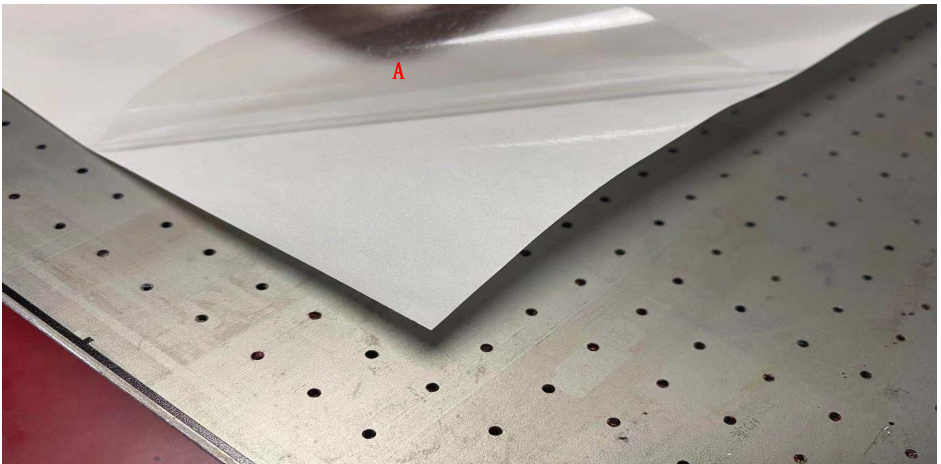

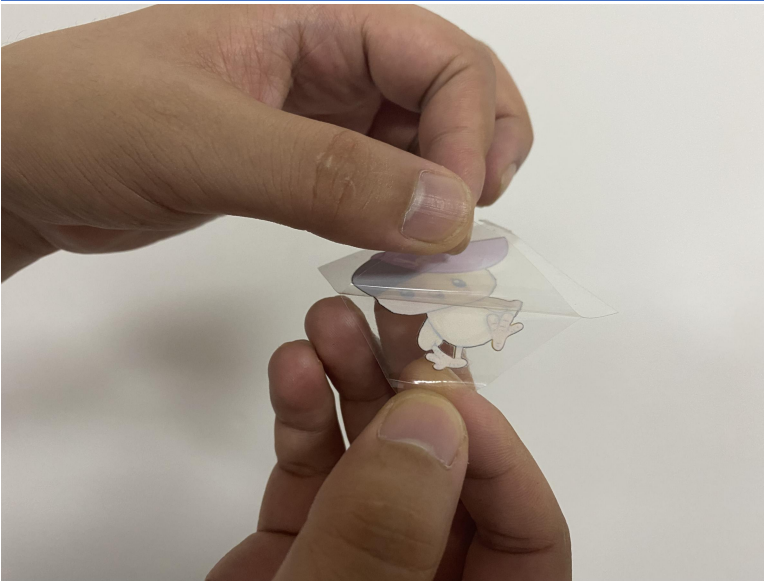

***After printing, pay attention to tear off the A film**



Then press on the surface of the product
to tear off the B film



UV Coil machine

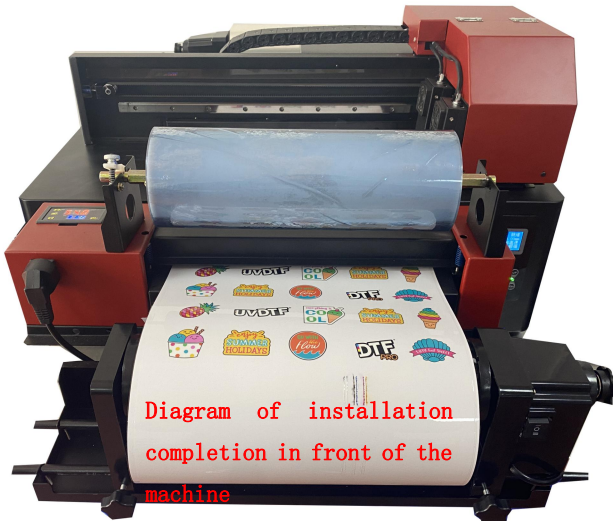

Set printing after installation (see installation video for installation tutorial)



Illustration of installation completion at the rear of the machine

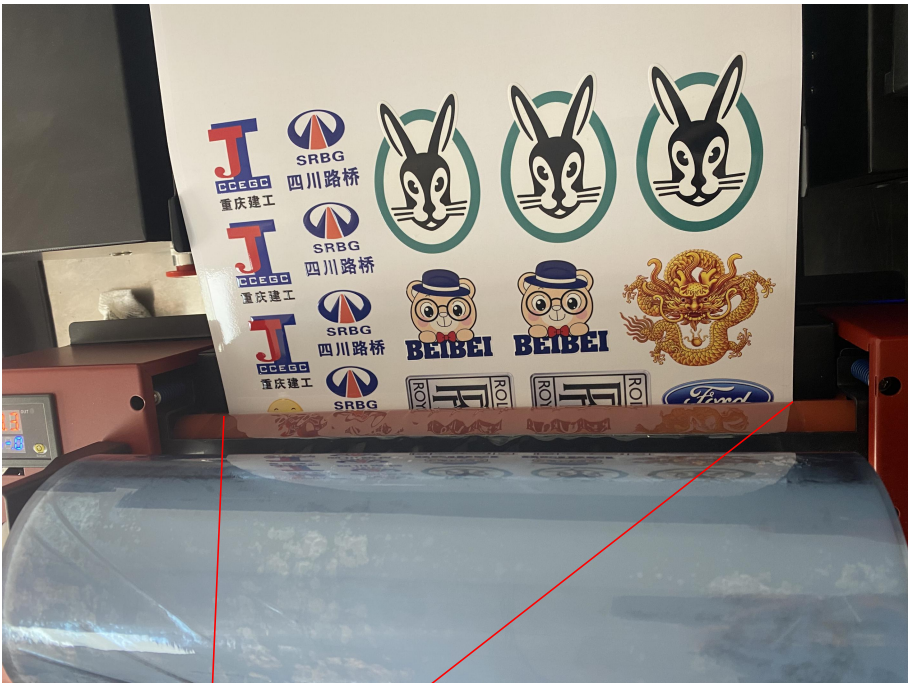

Align membrane A with membrane B before passing through

teaching video for printing details

Cloud Printing Series

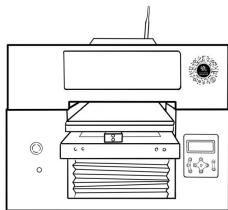

Desktop Smart Flatbed UV Printer

Operation Manual

Machine Parameters

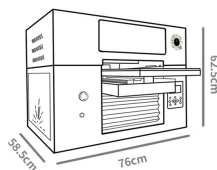

Describe	State
Print Head	Epson XP600
Printing method	5 color single nozzle on demand inkjet
Color pattern	C cyan, M magenta, Y yellow, K black, W white
Applicable product	Catering supplies,VEHICLE-mounted supplies, children's supplies,daily necessities,digital accessories,cultural and creative users,decorative supplies
Limited material	1.Weirdshape 2.soft material,strong ink absorption 3.the surface of the material is exceptionally smooth and reflective
Head Protection	Automatic cleaning/Manual cleaning
Touch-control computer	10.1-inch,1920x1200IPS screen,quad-core 1.92GHz
Machine dimension	58.5cm x 76cm x 62.5cm
Net weight	62kg
Packing method	Wooden case
Voltage requirements	50/60HZ AC220V (±10%) or AC110V (±10%)
Equipment power	40W/150W
Runtime environment	Best 20-28°C (68-82°F) HR40-60%
Ink Supply System	Special ink tube+ink bottle for inksupply
Operating software	PrintEXP + client + applet + H5

Machine Appearance

Front and Back

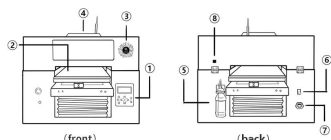

Describe	State
① Function keys	Basic operation can be carried out on the printer
② Material platform	Place the materials which need print on this platform
③ QR code	Printer HS code,scan code can start the customization
④ Touch-control computer	High performance mini computer
⑤ Waste ink loading bottle	Load the waste ink
⑥ Power switch	Printer AC Power On/Off button
⑦ power interface	Support220(±10%) , 110V (±10%)
⑧ Network interface	Connect the computer to achieve network communication

Two sides

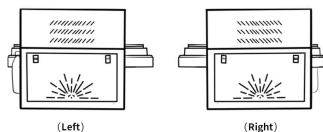

After opening the top cover baffle,ink can be added to the printer

Control Button

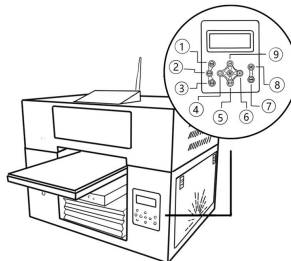

Describe	State
① NOZZLE	Print nozzle check to see the color come out condition
② PAUSE	Stop print
③ CLEAN	Clean head automatically
④ L	Carriage move Left
⑤ OUT	Tray move front
⑥ R	Carriage move Right
⑦ DOWN	Platform down
⑧ UP	Platform up
⑨ IN	Tray move back

Software Instruction



Describe	State
① Printer Number	Identify the printer number
② Sever Status	Display the connection status of the machine server Green: Machine connected the network Red: Machine network disconnected
③ PC Status	Display the connection status of the PC and machine Green: pc and printer connected successfully Red: pc and printer connection failure
④ Version Information	Printer software version information and print quantity
⑤ Print job list	Order to be printed, long pressing to choose cancel
⑥ Printing Orders	The list waiting for print
⑦ Start Print	Click one of the print job to star print
⑧ Job history list	Print job history list
⑨ About	About custom service information
⑩ Language	Switch language(Simplified/Traditional/English)
⑪ Ext	Exit App

4. Connect the power with machine

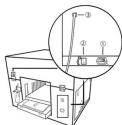

Connect AC power cable and network-cord, press switch ON power

6. Hand charge

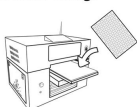

Select the material you want to print and place it on the platform and save the material

Limited material:

- 1.Strange shapes
- 2.Soft material,strong ink absorption
- 3.The surface of the material is exceptionally smooth and reflective
- 4.Maximum height of material>20cm

8. Measuring material (Cloudprinting)



Based on the width and height(mm)of the measured object,create the corresponding canvas size in the applet or H5,then design the work and generate the order

5. Load ink

1. Open PrintExp software



2. Click "Load Ink" about 30seconds, when the windows pop up "Stop" about 5seconds, then click "Load Ink" about 10seconds

3. In control panel press "Clean", clean twice

7. Scan code customization(Cloudprinting)



Open any APP have code scanning function(such as a browser),scan the QR code in the upper right corner of the front of the machine and start customization in the H5 link

9. Fixed materials



Take the lower right corner as the starting point and fix the material on the platform

Operation Instruction

1.Unwrap the package

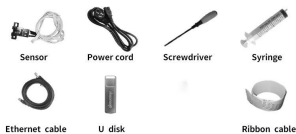

2. Remove the fixture



First: open the machine upper cover;
Second: use screwdriver remove number "1" screws;

Third: use scissor cut number "2" zip tape;

3.Add Ink

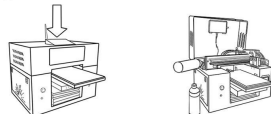

Open the top cover of the printer

Add ink into ink container according to the color labels on the top of the cap

10.Enable printing(cloud printing)



In the client order list,select the order you want to print,and click print order

11.Take away of goods



After printing,the platform will automatically push the material out,take it away

Matter need attention

- 1.Do not install and use the machine in the area where children will nearby
- 2.To reduce the absorption of chemicals through the skin, gloves should be worn when maintenance the machine or touch the ink.
- 3.Do not put the printer in unstable place,and avoid shake.
- 4.Please place the printer in a clean and cool place and avoid prolonged sunlight exposure
- 5.Place the printer in the sturdy table.
- 6.Do not use any broken power cable connect the printer.

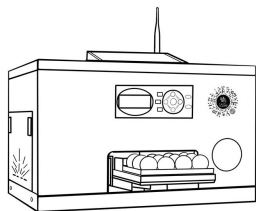

Desktop golf Self-service e-print

Operation Manual

Machine Parameters

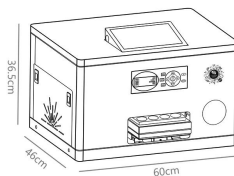

Describe	State
Printer Head	Epson XP600 Head
Print Method	Single head, 4 colors(CMYK) , ink-jet on demand
Color Mode	C Cyan . M Magenta . Y Yellow . K Black
Ink Capacity	UV Ink 250ml x 4
Printing Speed	2min / pics
Recommended case	golf
Printer head protection	Auto Clean / Manual Clean
Table PC	10.1 Inch , 1920 x 1200 IPS screen, Harper-town 1.92Ghz
Machine Size	60cm x 46cm x 36.5cm
Package Size	70cm x 54cm x 51cm
NW/GW	33kg / 46kg
Way of Packing	Carton
Voltage	50/60HZ 220V(±10%) 110V (±10%)
Machine Power	40W / 150W
Operating Environment	20-28°C (68-82°F) HR40-60%
Ink Supply System	Continuous Ink Supply System
Operation Software	PrintEXP + Client Server + App

Software introduction

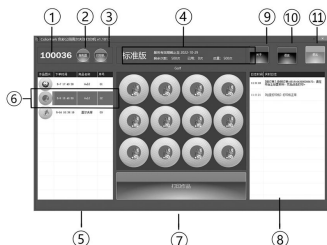

Describe	State
① Printer Number	Identify the printer number
② Sever Status	Display the connection status of the machine server Green: Machine connected to the network Red: Machine network disconnected
③ PC Status	Display the connection status of the PC and machine Green: pc and printer connected successfully Red: pc and printer connection failure
④ Version Information	Printer software version information and print quantity
⑤ Print job list	Order to be printed, keep pressing to cancel
⑥ Printing Orders	The list waiting for print
⑦ Start Print	Click one of the print job to star print
⑧ Job history list	Print job history list
⑨ About	About custom service information
⑩ Language	Switch language(Simplified/Traditional/English)
⑪ Ext	Exit App

Operation Instruction

1. Unwrap the package

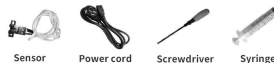

2. Remove the fixture



First: open the machine upper cover;

Second: use screwdriver remove number "1" screws;

Third: use scissor cut number "2" zip tape;

3. Add Ink

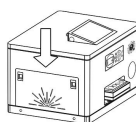

Open left side cover



Add ink into ink container according the color labels on the top of the cap

Machine Appearance

Front and Back

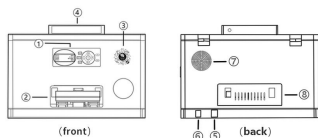

Describe State

Describe	State
① Button Function	See control panel for reference
② Platform	Put the object what you want to print there
③ QR Code	Scan the code to upload the picture that you want to print
④ Tablet PC	Touch-Controlled MINI Computer
⑤ Power connect port	Support 220V(±10%) , 110V (±10%)
⑥ Power Switch	Printer master switch
⑦ Ventilation and head dissipation	Continuous performance
⑧ Power radiator	Continuous performance

Two sides

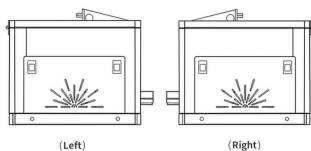

Left cover: Open the left cover to add ink

4. Connect the power with machine

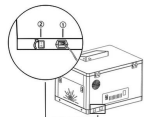

Connect power cord, press switch ON power

6. Scan the code



Open Wechat or any APP that with scan code function,scan the code,upload the photo that you need print, then start print.

8. Start print



Choose the photo that you need print from print job list,click "Print"

5. Load ink

1. Open PrintExp software



2. Click "Load Ink" about 30seconds, when the windows pop up "Stop" , about 5seconds, then click "Load Ink" about 10 seconds.

3. In control panel press "Clean" , clean twice

7. Place object



Place the object on the platform, and keep them even

9. Finished print and take out the object



The tray will go out when it finished print, then take out the print object

Control Button

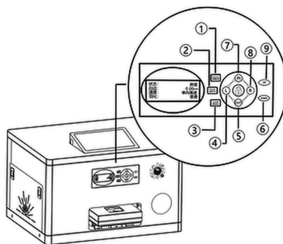

Describe State

Describe	State
① NOZZLE	Print nozzle check to see the color come out or -ndition
② PAUSE	Stop print
③ CLEAN	Clean head automatically
④ L	Carriage move Left
⑤ OUT	Tray move front
⑥ DOWN	No function for it(ignore)
⑦ IN	Tray move back
⑧ R	Carriage move Right
⑨ UP	No function for it(ignore)

Trouble shooting

Server status shows in red

Please confirm if the Touch-Controlled Mini Computer has connected WI-FI. If not, need connect WI-FI first, Click Menu bar icon at the bottom of the computer, Click "Others Network" , then Click "Others"

Printer status show in red

Confirm that the software is at work, if not please double-click the icon and open the software.

Matter need attention

1. Do not install and use the machine in the area where children will nearby.
2. To reduce the absorption of chemicals through the skin, gloves should be worn when maintenance the machine or touch the ink.
3. Do not put the printer in unstable place, and avoid shake.
3. Do not place the printer where there is big temperature difference and avoid direct sunlight.
4. Do not place the printer in an uneven place, printer must work in an even place.
5. Place the printer in the sturdy table.
6. Do not use any broken power cable connect the printer.

Important notification

Bellow situations not under the warranty scope:

1. The problem cause because of not use the accessories and consumables that come from our company.
2. The problem cause because of not use our suitable ink
3. Unauthorized maintenance, misuse, crash, abuse, accident, modify or cripple, alter labeling, false proof.
4. Damage by any force majeure or human.

Machine Parameters

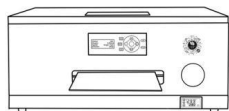

Offset printing transfer self-service cloud printing

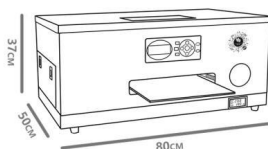

Describe	State
Machine model	CF1/CF2
Machine Size	800mm x 500mm x 370mm
Print platform	300mm wide PET film
Voltage requirements	50/60 HZ 220V (±10%) ≤3.5V 110V (±10%) ≤ 7V
Runtime environment	20-28°C (68-82F) HR40-60%
Nozzle type	XP600
Ink curing system	UV lamp and air cooled circulation
Printing software	PrintEXP+Color Park client
Print file format	TIFF/JPG, DPI ≥ 300
Computer System Requirements	Win7/8/10 64bit
Ink requirements	YMCK+W
End connections	RJ45 Network interface

Operation Manual

Software Instruction



Describe	State
① Printer Number	Identify the printer number
② Sever Status	Display the connection status of the machine server Green: Machine connected the network Red: Machine network disconnected
③ PC Status	Display the connection status of the PC and machine Green: pc and printer connected successfully Red: pc and printer connection failure
④ Version Information	Printer software version information and print quantity
⑤ Print job list	Order to be printed, keep pressing to cancel
⑥ Printing Orders	The list waiting for print
⑦ Start Print	Click one of the print job to star print
⑧ Job history list	Print job history list
⑨ About	About custom service information
⑩ Language	Switch language(Simplified/Traditional/English)
⑪ Ext	Exit App

Operation Instruction

1.Unwrap the package



2. Remove the fixture



First: open the machine upper cover;
Second: use screwdriver remove number "1" screws;
Third: use scissor cut number "2" zip tape;

3. Add Ink

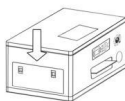

Open left side cover



Add ink into ink container according the color labels on the top of the cap

Machine Appearance

Front and Back

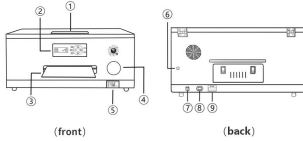

Describe State

① Skylight perspective	Can view the working status of printing directly
② Function keys	Basic operation can be carried out on the printer
③ QR Material platform	Material outlet
④ Nozzle window	Visualization window of sprinker working status
⑤ Temperature of panel	Display machine operating temperature status
⑥ Network interface	Connect computer to realize network communication
⑦ Main switch	Control the machine to switch on and off
⑧ Power interface	Put through power supply

Two sides

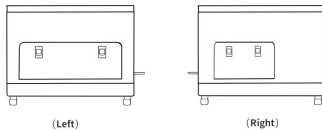

Left cover: Open the left cover to add ink

4. Connect the power with machine

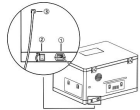

Connect power cord and network cord, press switch ON power

6. Scan the code (cloud print)

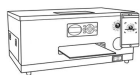

Open Wechat or any APP that with scan code function,scan the code,upload the photo that you need print, then start print.

8. Start print (cloud print)



Choose the photo that you need print from print job list,click "Print"

5. Load ink

1. Open PrintExp software



2. Click "Load Ink" about 30seconds, when the windows pop up "Stop", about 5seconds, then click "Load Ink" about 10 seconds.

3. In control panel press "Clean", clean twice

7. Place object



Place the object on the platform, and keep them even

9. Finished print and take out the object



The tray will go out when it finished print, then take out the print object

Control Button

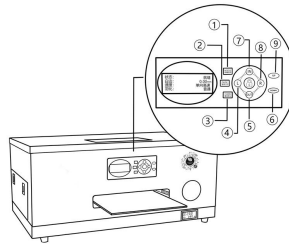

Describe State

① NOZZLE	Print nozzle check to see the color come out condition
② PAUSE	Stop print
③ CLEAN	Clean head automatically
④ L	Carriage move Left
⑤ OUT	Tray move front
⑥ DOWN	No function for it(ignore)
⑦ IN	Tray move back
⑧ R	Carriage move Right
⑨ UP	No function for it(ignore)

10. Shake powder drying

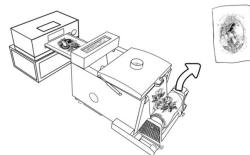

Connect the printed PET film to the powder shaking machine, which can automatically realize the function of powder shaking and drying

11. Transfer membrane pyrograph

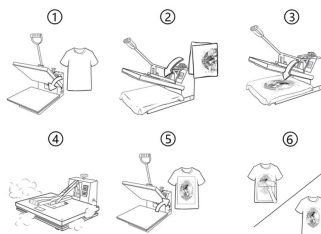

12. Matter need attention

1. Do not install and use the machine in the area where children will nearby.
2. To reduce the absorption of chemicals through the skin, gloves should be worn when maintenance the machine or touch the ink.
3. Do not put the printer in unsuitable place, and avoid shake.
4. Do not place the printer where there is big temperature difference and avoid direct sunlight.
5. Do not place the printer in an uneven place, printer must work in an even place.
6. Place the printer in the sturdy table.
7. Do not use any broken power cable connect the printer.

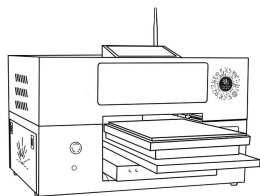

Desktop clothing Self-service e-print

Operation Manual

Software introduction



Describe	State
① Printer Number	Identify the printer number
② Sever Status	Display the connection status of the machine server Green: Machine connected the network Red: Machine network disconnected
③ PC Status	Display the connection status of the PC and machine Green: pc and printer connected successfully Red: pc and printer connection failure
④ Version Information	Printer software version information and print quantity
⑤ Print job list	Order to be printed, keep pressing to cancel
⑥ Printing Orders	The list waiting for print
⑦ Start Print	Click one of the print job to star print
⑧ Job history list	Print job history list
⑨ About	About custom service information
⑩ Language	Switch language(Simplified/Traditional/English)
⑪ Exit	Exit App

Machine Parameters

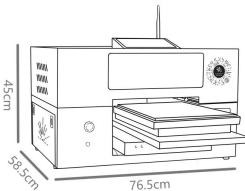

Describe	State
Printer Head	Expson XP600 Head
Print Method	Single head, 4 colors(CMYK) , ink-jet on demand
Color Mode	C Cyan . M Magenta . Y Yellow . K Black
Ink Capacity	UV Ink 250ml x 4
Printing Speed	5min / pics
Recommended material	Light color T-shirts, hoodies, POLO shirts with cotton over 50%
Printer head protection	Auto Clean / Manual Clean
Table PC	10.1 Inch , 1920 x 1200 IPS screen , Harper-town 1.92Ghz
Machine Size	76.5cm x 58.5cm x 45cm
Package Size	90cm x 89cm x 70cm
NW/GW	50kg
Way of Packing	Wooden case/carton
Voltage	50/60HZ 220V(±10%) 110V (±10%)
Machine Power	40W / 150W
Operating Environment	20-28℃ (68-82°F) HR40-60%
Ink Supply System	Continuous Ink Supply System
Operation Software	PrintEXP + Client Server + App

Operation Instruction

1. Unwrap the package

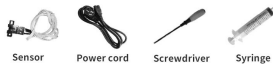
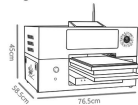

2. Remove the fixture



- First: open the machine upper cover;
- Second: use screwdriver remove number "1" screws;
- Third: use scissor cut number "2" zip tape;

3. Add ink

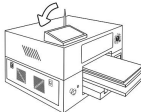

Open the top cover of the printer

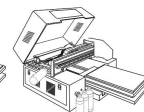

Add ink into ink container according the color labels on the top of the cap

Machine Appearance

Front and Back

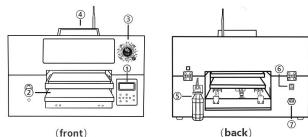

Describe	State
① Button Function	See control panel for reference
② Platform	Put the object what you want to print there
③ QR Code	Scan the code to upload the picture that you want to print
④ Tablet PC	Touch-Controlled MINI Computer
⑤ Waste cartridge	Loading of waste ink
⑥ Power Switch	Printer master switch
⑦ Power interface	Printer master switch

Two sides

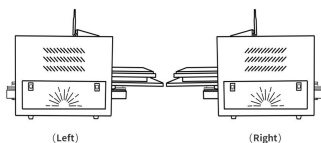

After opening the top cover baffle, ink can be added to the printer

Control Button

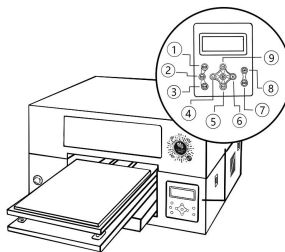

Describe	State
① NOZZLE	Print nozzle check to see the color come out condition
② PAUSE	Stop print
③ CLEAN	Clean head automatically
④ L	Carriage move Left
⑤ OUT	Tray move front
⑥ R	Carriage move Right
⑦ DOWN	No function for it(ignore)
⑧ UP	No function for it(ignore)
⑨ IN	Tray move back

4. Connect the power with machine



Connect power cord, press switch ON power

6. Scan the code

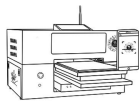

Open Wechat or any APP that with scan code function,scan the code,upload the photo that you need print, then start print.

8. Start print



Choose the photo that you need print from print job list,click "Print"

5. Load ink

1. Open PrintExp software



2. Click "Load Ink" about 30seconds, when the windows pop up "Stop", about 5seconds, then click "Load Ink" about 10 seconds.

3. In control panel press "Clean", clean twice

7. Place object



Place the object on the platform, and keep them even

9. Finished print and take out the object



The tray will go out when it finished print, then take out the print object

10. Ink pyrograph

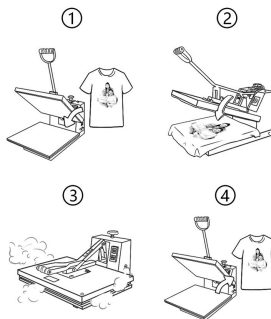

Matter need attention

1. Do not install and use the machine in the area where children will nearby.
2. To reduce the absorption of chemicals through the skin, gloves should be worn when maintenance the machine or touch the ink.
3. Do not put the printer in unstable place, and avoid shake.
4. Do not place the printer where there is big temperature difference and avoid direct sunlight.
5. Do not place the printer in an uneven place, printer must work in an even place.
6. Place the printer in the sturdy table.
7. Do not use any broken power cable connect the printer.

Product warranty card.

Dear customer.

Thank you for purchasing this product please read the instructions before use, the correct operation of the printer, please refer to the instructions in advance troubleshooting check, in troubleshooting can not troubleshoot the case, please contact the company's technical staff, the company will provide quality after-sales service for the topic.

Warranty Treaty and Statement.

1. The warranty period from the time of receipt of the machine to calculate, under normal circumstances to use this product and failure, according to the provisions of the warranty to give repair, replacement, return.

2. In the case of secondary sales, this product supports seven days without reason for return (adding ink after affecting the second sale).

2. The goods during the warranty period can only be repaired at the specified repair point of the Company, please present the warranty card and purchase machine invoice at the time of warranty.

3. Customers from the beginning of the purchase of 3 years, all belong to the quality of this product, can be free product warranty services.

4. This warranty card service does not include repair personnel on-site service, mailing fees, transportation costs, supplies and accessories.

Consumables include: nozzle, ink sac, ink pad, ink pump, ink, ink tube.

5. Additional accessories (U disk, manual, etc. lost damage, Company no longer provides this.

6. No liability for any indirect loss to the user as a result of the product failure and future gains.

7. Invoice, product warranty card completed incomplete, tampering, forgery, the warranty information recorded by will prevail.

8. This warranty card will not be reissued after the loss, please keep it safe.

9. The following conditions, within the warranty period (including warranty validity), do not enjoy warranty services (unless otherwise agreed with The Company):

(1) Failure to operate, maintain, store damage (e.g., power supply, temperature, humidity) as required by the instruction manual.

(2) Due to the user using the non Company original, designated accessories, resulting in a failure.

(3) Machine failure and damage caused by improper user custody (e.g. rat damage, liquid infiltration, foreign object entry and other similar causes), or loss of parts.

(4) Damage caused by a drop caused by the user itself, and damage to the fault caused by a collision.

(5) Without the authorization of private dismantling machine, repair and modification caused by the failure, damage.

(6) Because the user cannot present a valid warranty certificate (warranty card, invoice).

(7) Damage due to incapacity (earthquake, fire, flood)



Cut along the dotted line.

product warranty card.

Product Name: _____ Purchase Name: _____

Modle: _____ Warranty
Period: _____

Product No: _____

Customer Name: _____ Email: _____

Phone: _____ Zip
Code: _____

Address: _____

Repair Records

Date of acceptance.			
Description of the cause of the failure and treatment.			
Sign-in and sign-off date.			

