

GVM

GVM 1200B AIO

CONTENTS

Important Safety Instructions -----	Page 1~2
Warning -----	Page 2
Product Introduction -----	Page 3
Disclaimers -----	Page 3
Product Parameter -----	Page 4
Precautions -----	Page 4
Product Structure Diagram -----	Page 5
Installation Method -----	Page 6~9
Description Of Product Control Keys -----	Page 10
Function Introduction & Instructions For Use -----	Page 11~15
APP Control -----	Page 16~17
Quick Troubleshooting -----	Page 18
Use And Maintenance -----	Page 19
Packing List -----	Page 19
Product Warranty -----	Page 20~21

IMPORTANT SAFETY INSTRUCTIONS

This product is professional lighting and staging equipment and should only be operated by a qualified lighting technician or used under the supervision of a professional. Always follow the precautions below to ensure safe and proper usage.





1. Read the product manual carefully before use.
2. This product is only suitable to use in a temperature range of -20°C to 45°C.
3. Do not place the equipment near flammable and volatile solvents such as alcohol and gasoline.
4. Before storing the device, make sure it has cooled down completely. When being stored, unplug the power cord from the device. The equipment should be stored in its carrying case or a well-ventilated and dry place.
5. This lighting fixture is not for general illumination and should not be used as such. Individuals with eye injuries or sensitivity should avoid using this lighting fixture.
6. This is a professional light and children are prohibited from using it. Parents or guardians must closely supervise children when they are near the equipment to prevent personal injury caused by colliding with or misusing the equipment.
7. Before using the equipment, please remove the protective cover.
8. When the lighting fixture is on, it is forbidden to stare directly at the light source under any circumstances. High-intensity lighting should only be used under the guidance of a professional lighting technician. Avoid staying in a high-intensity light environment for a long time. If feeling any discomfort, please immediately turn off the lighting fixture, and seek medical attention.
9. When the lighting fixture is on, use it carefully and avoid contacting high-temperature components such as LED light sources to prevent being burnt.
10. Do not use damaged equipment or accessories. Wait for a professional repairman to inspect and repair it before it is confirmed that the equipment can function normally.
11. If the light source is damaged or deformed due to heat, please stop using it and contact the manufacturer, service agents, or qualified repairman promptly to replace the light source to avoid accidents.
12. If the product is cracked due to falling, squeezing, or strong impact during use, please stop use it to avoid being electrically shocked by touching internal electronic components.
13. Do not disassemble the product by yourself. If the product malfunctions, it must be checked and repaired by the manufacturer or authorized repair personnel.
14. Before cleaning and maintenance, be sure to unplug the power supply. To unplug never pull on the cable but always pull the plug itself. This device shall only operate with earthed power outlets or emergency power generators.
15. When cleaning the device, do not wipe it with a wet cloth. Use a dry and soft cloth to wipe off the dirt.
16. If an extension cord is required, it needs to have the necessary capacity to power the respective unit. Using an extension cord with a lower current capacity than the devices need may cause overheating.

17. For some products with long power cords, please place the power cords properly and avoid contact with overheated surfaces that may damage or trip personnel. Please use the original power cords of our manufactory. The damage caused by using non-original power cords is not covered by our repair service.
18. Do not use product accessories that are not recommended by our brand to avoid fire, electric shock, or personal injury.
19. Some products use batteries for power supply. Do not use any batteries, power sources, or accessories that are not specified in the user manual. Please keep batteries and other accessories out of reach of children and infants. If a child or infant swallows a battery or accessory, seek medical attention immediately. If the battery leaks, changes color, deforms, smokes, or emits an odor, remove it immediately. Be careful not to get burned during the removal. Continued use of such batteries may cause a fire, electric shock, or skin burns. Do not use any deformed or modified batteries. Do not disassemble or modify this product or the battery. Do not heat the battery or solder it. Do not let the battery come into contact with fire or water, or subject it to strong external force. Do not insert the battery's positive and negative ends incorrectly, or mix and use old and new batteries or different types of batteries.
20. For some products with built-in lithium batteries, please use a dedicated charger for charging, and following the correct operating instructions within the prescribed voltage and temperature range.
21. The warranty last for one year. Consumables like batteries, adapters, power cords, and other accessories are not covered by the warranty.
22. The one-year warranty will be invalidated if the equipment is found to have been repaired privately. The related repair costs will be charged.
23. Equipment malfunctions caused by non-standard operations are not covered by the warranty.
24. The safety instructions are based on our factory's strict testing. If there are any changes in the equipment's design and specifications, we reserve the right not to notify you. Customers can visit our official website to check the latest digital version of the instructions and learn about the newest product information.

Keep these instructions!



WARNING:

-  High-power LED lights are strictly prohibited from being directly viewed or shining into other people's eyes.
-  Do not unplug the power cord or connecting wires while the light is on to avoid personal injury.
-  Do not cover the heat dissipation port when the lamp is in operation.
-  Keep children away from touching or using this light.
-  As professional lighting equipment, please make sure to operate it correctly according to the user manual.

PRODUCT INTRODUCTION

Thank you for purchasing the “GVM 1200B AIO”. This product is specifically designed for photography and videography enthusiast. This product is suitable for use in live stream /outdoor /studio and YouTube shoots.

The main features of the product are:

1. This light features seamless dimming and is equipped with COB LED technology light engine with a CRI of 97+. It has a bi-color temperature range of 2700K to 6800K. It can effectively enhances color accuracy and richness, ensuring natural and vibrant light quality.
2. APP control, This light can be controlled via your IOS and Android smart mobile devices; as well as be group controlled along with other GVM brand devices that support Bluetooth mesh networking.
3. It is equipped with a build in data transmission port and can be connected with the GVM BOX series accessories to enable wire DMX control and CRMX control. (Accessories need to be purchased separately.)
4. 3 types of lighting modes: CCT mode, Source Matching mode, and Effects mode.
 - CCT Mode: Adjust the light's intensity and color temperature as needed.
 - Source Matching Mode: **This mode can only be accessed through the APP.** Choose from 12 simulated light sources: Tungsten, HMI5600, HMI6000, Studio Lamps, Sodium Lamp, Halogen, Arc Lamp, Candle, Sunset/Sunrise, Daylight, Overcast Sky, CFL Cool White.
 - Effects Mode: **This mode can only be accessed through the APP / DMX / CRMX / Network port.** Choose from 12 simulated light effects: Lightning, CCT Loop, Candle, Bad Bulb, TV, Paparazzi, Explosion, Pulsing, Strobe, Fire, Fireworks, Welding.

We firmly believe that, proper use of this product will greatly enhance your production workflow. We strongly recommend reading the following user guide carefully before using the product.

DISCLAIMERS

1. Before using this product, please read the text carefully to ensure that the correct operation of the product has been carried out. Failure to follow and not following the instructions and warnings in this document may cause harm to you and others around you, or even damage the product or other surrounding items.
2. By using this product, you are deemed to have carefully read the disclaimer and warning, understand and acknowledge all the terms and contents of this statement, and promise to take full responsibility for the use of this product and the possible consequences.
3. Design and specifications are subject to change without notice.

PRODUCT PARAMETER

- ◆ Brand : GVM
- ◆ Product Model : GVM 1200B AIO
- ◆ Product Name : LED Video Light
- ◆ Product Type : COB Point Source Light
- ◆ Features : CCT/Source Matching/Effect mode, brand-new LCD screen, high color rendering index LED light engine, support for RDM
- ◆ Control Methods : On board control, GVM Mesh Bluetooth APP control, DMX control
- ◆ The data port can be optionally equipped with accessories: ① DMX/RDM (UNIT-BD), ② CRMX+DMX (UNIT-CD), ③ Ar-Net/sCAN (UNIT-E)
- ◆ Bluetooth Controllable Distance : ≤50M
- ◆ Color Rendering Index : ≥97
- ◆ Color Temperature : 2700K~6800K
- ◆ Illumination : Bare bulb 6240 lux@3m, 2350 lux@5m;
Standard reflector 25700 lux@3m, 8510 lux@5m
- ◆ LED Chip Quantity : 1 (COB light Chip)
- ◆ Light Adjustment Method : Step-less adjustment
- ◆ Power : 1200W
- ◆ Product Net Weight : 12.5 KG(incl. yoke), 10.6 KG(excl. yoke)
- ◆ Product Size (mm) : 633×312×291(incl. yoke), 420×312×291(excl. yoke)
- ◆ Power Supply Method: Power supply by AC adapter
- ◆ Adapter Specification: Input AC100V - 240V
- ◆ Cooling : Heat Sink Radiating + Cooling Fan
- ◆ Product Material : Aluminum alloy + Plastic
- ◆ Commodity Origin : Huizhou. China

PRECAUTIONS

1. Please use the matching power adapter the same specification to power the product. Do not use power adapter with different output voltage parameters.
2. The product is not waterproof, please use it in a rainproof environment.
3. The product is not anti-corrosion, therefore do not let the product touch any corrosive liquid.
4. When using the product, make sure the product is put firmly and prevents falling and damage.
5. If the product will not be used for a long time, please switch off the power to reduce energy loss.

PRODUCT STRUCTURE DIAGRAM

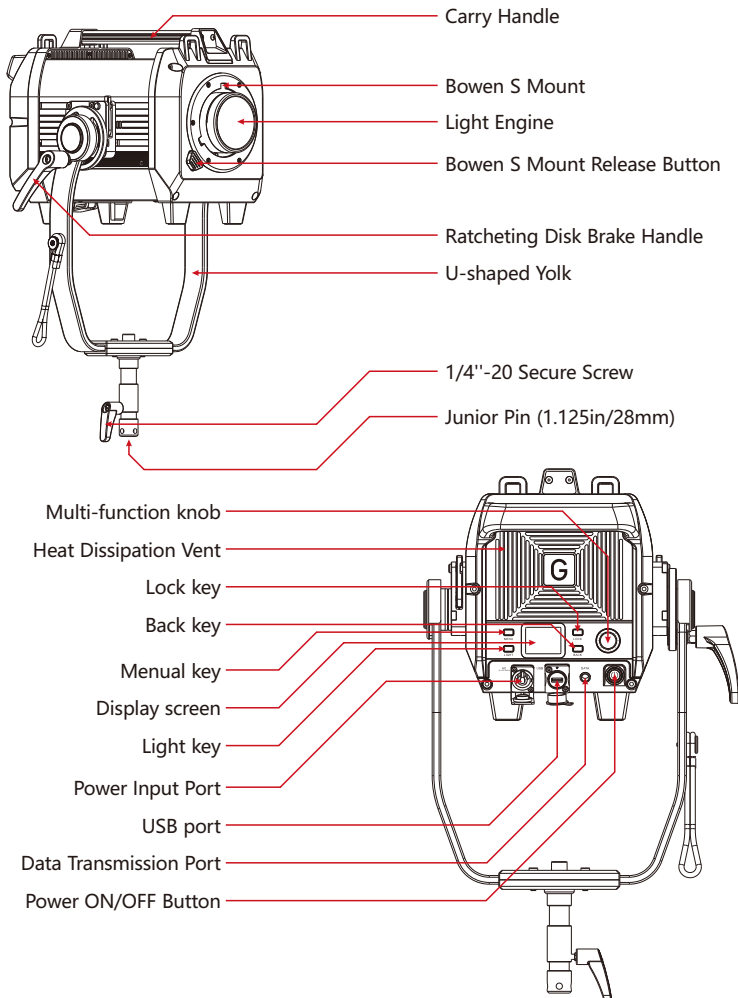

INSTALLATION METHOD

- 1 Slide the 5/8" receiver over the spigot/stud at the top of the light stand. Lower it fully down so the receiver fits snugly onto the stand. Tighten the securing knob on the yoke. Make sure the light does not wobble or spin.

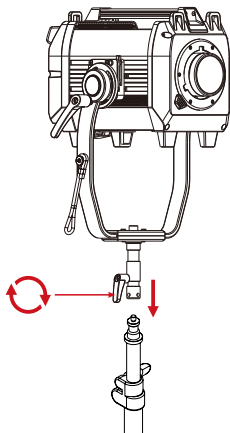

- 2 Loosen the angle locking handle on the side of the yolk then adjust the tilt angle of the light to your needs, and then tighten the angle locking handle.

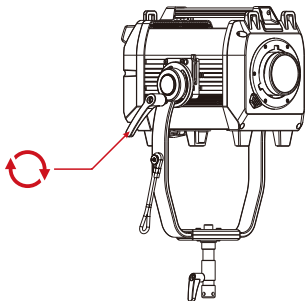

- 3** Installation and removal of standard reflector.
(Standard reflector need to be purchased separately.)

Installation:

Match the three prongs (lugs) on the reflector with the notches on the light's Bowens mount. Insert the reflector by pushing it straight in so the prongs slide into the corresponding notches. Once inserted, rotate the reflector clockwise. You should feel or hear a "click" or "snap" when it locks in place.

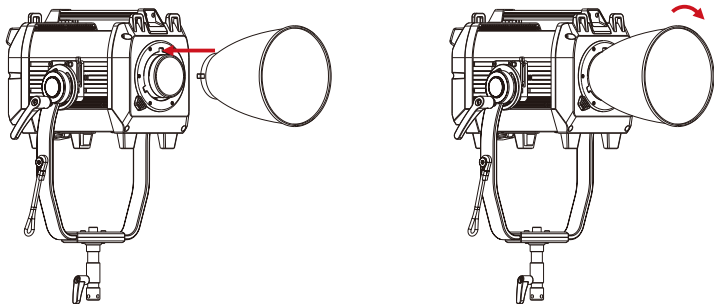

Detach:

Gently press and hold the release button, twist the reflector counterclockwise. After twisting, pull the reflector straight out from the mount.

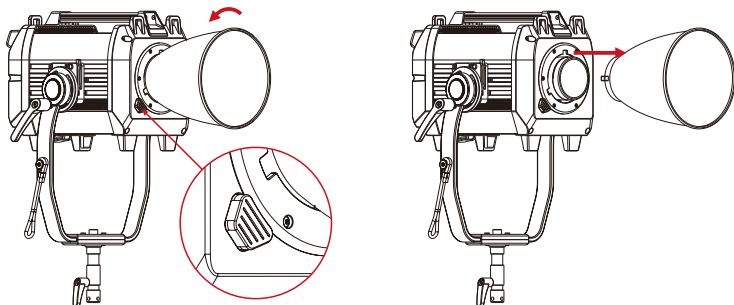

Bowens mount
release button

4 Disassemble the light from the U-shaped yolk:

Press the release mechanism on both side of the yolk, then pull the light straight up to remove it from the frame.

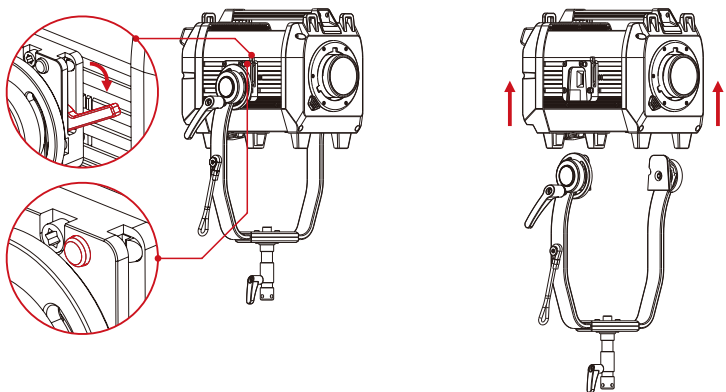

Installing the light to the U-shaped yolk:

Align the grooves on both side of the yolk, Insert the light from top to bottom into the yolk until the lock of the U-frame automatically locks.

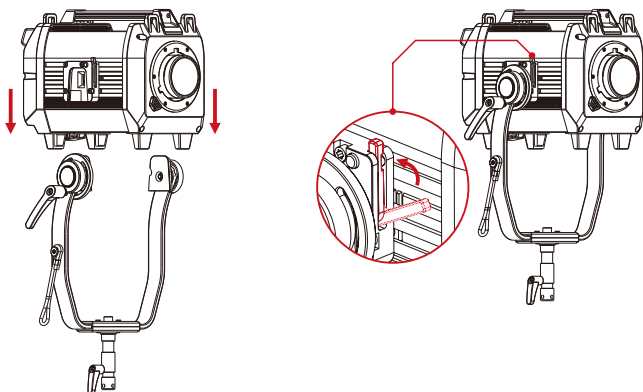

- 5 Connect the power cord to the power supply.

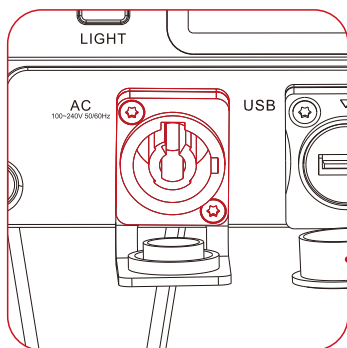

Power input interface

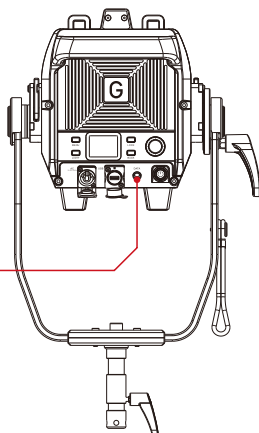

- 6 The data transmission port can be connected to the GVM DMX box accessory and corresponding control function can be carried out.

(The accessories need to be purchased separately. The supported accessories models includes: DCB-XLR5(DMX&RDM), CCB-XLR5(CRMX&DMX), LCBRJ45(Ethernet Art-Net/sACN).)

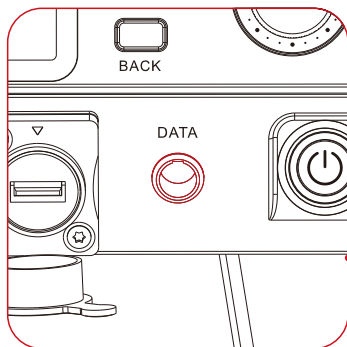

Data transmission port

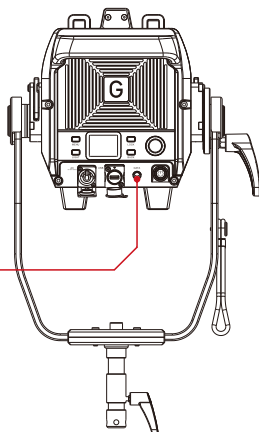

DESCRIPTION OF PRODUCT CONTROL KEYS

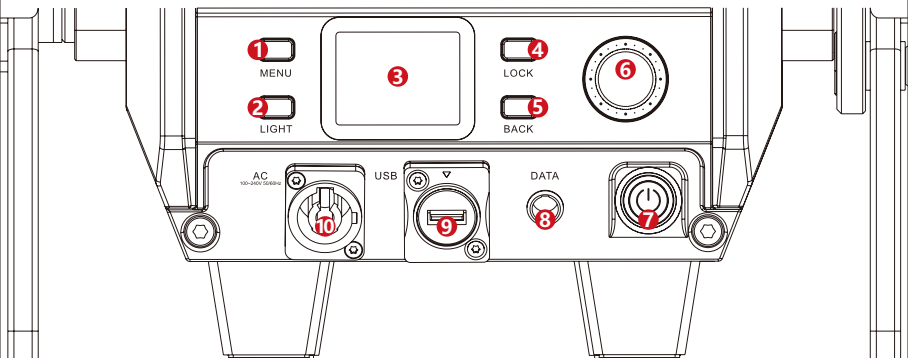

- ❶ Menu key: Enter the system menu Settings.
- ❷ Light key: Enter CCT dimming mode.
- ❸ Display: Displays the current Settings, modes, and parameters.
- ❹ Lock key: Press and hold for 2 seconds to lock/unlock. After locking, the key and knob will be unavailable.
- ❺ Back key: Press this key to return to the previous menu.
- ❻ Knob:
 - 【Rotate】 Select a menu and adjust parameters.
 - 【Click】 Go to the menu or confirm the selection.
- ❼ ON/OFF key: Long press this key to power On/Off the light.
- ❽ Data transmission port: Connect the GVM BOX series accessories to achieve the corresponding control mode.
(The attachments need to be purchased separately. The supported attachment models are: DCB-XLR5(DMX&RDM), CCB-XLR5(CRMX&DMX), LCB-RJ45(Ethernet Art-Net/sACN.)
- ❾ Type-C data port: Supports inserting a USB flash drive for firmware update.
(Does not support power deliver or power pass through. Such as charging an external device.)
- ❿ Power port: Connect to the power cable to supply power to the light.

FUNCTION INTRODUCTION & INSTRUCTIONS FOR USE

① MENU:

Press the [Menu] key to enter the system menu Settings → Rotate the [knob] to select menu → Press the [knob] to enter the Settings interface of the selection menu → Press the [BACK] key to return to the previous level menu.

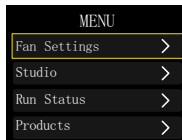
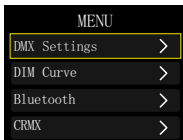

This function can only be accessed by connecting to the external GVM data box accessories.

The GVM data box accessories needs to be purchased separately. The supported accessories models are: DCB-XLR5(DMX&RDM), CCB-XLR5(CRMX&DMX).

Connect the GVM data box to the data transmission port → Rotate the [knob] to select → Press the [knob] to enter the selection.

DMX address: Rotate the [knob] to select the DMX address number.

DMX mode: Rotate the [knob] to select the DMX mode → Press the [knob] to confirm the selection.

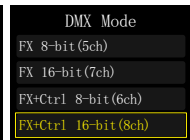
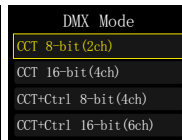
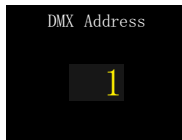
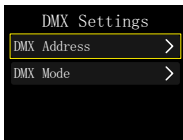

DIM Curve

Rotate the [knob] and select [Linear/Exp/Log/S-Curve] → Press the [knob] to confirm the selection.

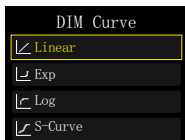

Bluetooth

Rotate the [knob] to select → Press the [knob] to enter the selection.

BT state: Rotate the [knob] to select [Open/Close] Bluetooth → Press the [knob] to confirm the selection.

BT Reset: Rotate the [knob] to select [Yes/No] to reset Bluetooth → Press the [knob] to confirm the selection.

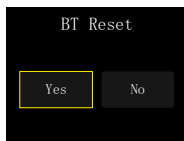
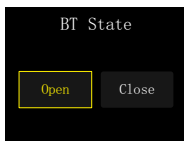
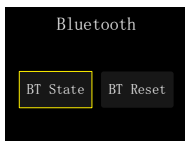

CRMX

This function can only be used by connecting to the external GVM data box accessories.

The GVM data box needs to be purchased separately. The supported attachment models are: CCBXLR5(CRMX&DMX).

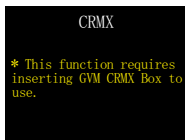

Fan Settings

Rotate the [knob] to select [Smart/High/Silent] → Press the [knob] to confirm the selection.

Smart: Adjust the fan speed as the temperature changes.

High: The fan operates at the maximum rotational speed.

Silent: The silent mode will stop the fan from rotating and reduce the light output power to 110W. It is not recommended to use this mode for a long period of time.

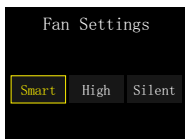

Studio

Rotate the [knob] to select [Open/Close] → Press the [knob] to confirm the selection.

Open: When the Studio mode is turned on, the settings you have made will be applied the next time you power on the unit.

Close: When the Studio mode is turned off. The light will go back to its default settings after powering on the next time.

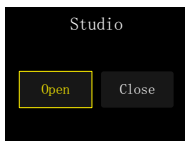

Run status

Check the current [Lamp Temp] and [Fan speed] of the product.

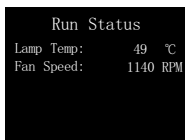

Products

Check the current [Firmware VN] and [Hardware VN] of the product.

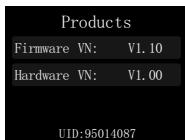

Language

Rotate the [knob] to select the language text displayed on the screen English/中文] → Press the [knob] to confirm the selection.

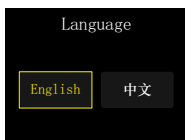

Upgrade

Download the upgraded firmware to a USB drive from the official website → Connect a USB flash drive with upgraded firmware to the lamp → Rotate the [knob] to select [Yes/No] upgrade → Press the [knob] to confirm the selection.

The file system format of the USB flash drive must be FAT32; otherwise, the USB flash drive may not be recognized.

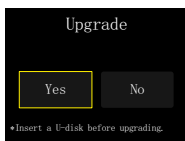





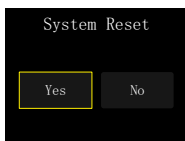





System Reset

Rotate the [knob] and select [Yes/No] to reset the system → Press the [knob] to confirm the selection.



② Status indication specification :

	Dimming curve: Linear		Dimming curve: Exp		Fan mode: Smart
	Dimming curve: Log		Dimming curve: S		Fan mode: High
	Bluetooth connected				Fan mode: Silent
	DMX mode is enabled and the DMX console is connected.				
	The attachment is successfully connected and the corresponding function can be used. The attachments need to be purchased separately. The supported accessory models are: DCB-XLR5(DMX&RDM), CCB-XLR5(CRMX&DMX), LCB-RJ45(Ethernet Art-Net/sACN).				

③ CCT:

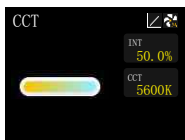

Rotate the [knob] to select [INT/CCT]→ Press the [knob] to confirm the selection.

INT: Rotate the [knob] to adjust the intensity parameter of the light.

CCT: Rotate the [knob] to adjust the color temperature parameter of the light.

④ Source matching mode:

The source matching mode can only be accessed through the APP.

This mode has 12 simulated light sources. Tungsten, HMI5600, HMI6000, Studio Lamps, Sodium Lamp, Halogen, Arc Lamp, Candle, Sunset/Sunrise, Daylight, Overcast Sky, CFL Cool White.

⑤ Effect mode:

The effect mode can only be accessed through the APP.

This mode has 12 simulated light effect. Lightning, CCT Loop, Candle, Bad Bulb, TV, Paparazzi, Explosion, Pulsing, Strobe, Fire, Fireworks, Welding.

APP CONTROL

APP Download Method

(Scan the QR code on the back of the manual to download the APP)

Android Device: Official website QR code, Google Play, Huawei Store, etc.

iOS Device: App Store

Device-adding

1. Before adding a device, please make sure you have turned on your phone's Bluetooth and network data, accessibility to Bluetooth and network data, then reset the lighting device's Bluetooth.
2. Click the "Add Device" button on the "My Devices" page to find the Bluetooth light devices that have been turned on nearby. (Figure 1)
3. Select the device to be connected for pairing. (Figure 2)

* Android requires location permissions to be turned on in order to connect your device using mesh technology, and we do not collect any of your location information during this process.

Device Management

1. After successfully adding your lighting device, your device will be displayed in the "My Devices" list. (Figure 3)
2. Click on the Device to access the device control. (Figure 4)

Figure 1

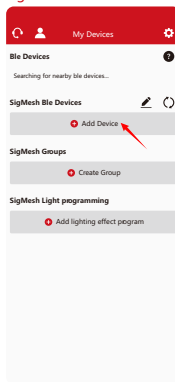

Figure 2

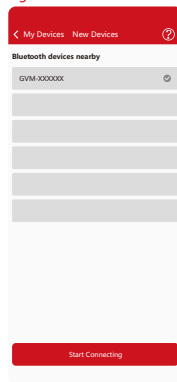

Figure 3

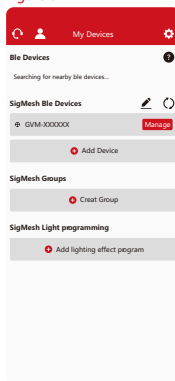
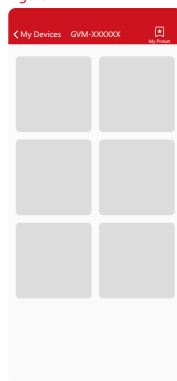

Figure 4



Account Login

- ◆ Use e-mail to get the verification code to log in (the first login automatically registers the account). (Figure 5)
- ◆ There may be a delay in sending the verification code, and the speed of delivery depends on the e-mail server you are using.
- ◆ Some email servers may recognize our verification emails as advertising promotions, please check your spam folder/inbox.
- ◆ After logging in, you can synchronize the Mesh Bluetooth devices bound to the current account to other smart devices.

Figure 5

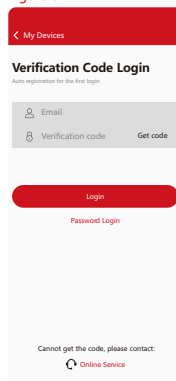

QUICK TROUBLESHOOTING

Issue	Check the product	Troubleshooting
The indicator does not light up.	Whether the connection between the light and the power supply is normal.	Make sure the adapter is well connected with the power plug.
While using the APP to add a device, the Bluetooth of the device cannot be found.	Check if the device is turned on properly and that it is not already paired by someone else connection.	Follow these steps: 1. Turn on phone's Bluetooth and network data function, android devices need to turn on the GPS positioning. 2. Allow access to Bluetooth and network data, GPS positioning. 3. Reset the device Bluetooth according to the user manual.
The APP failed to pair to a device.	Check if the device is turned on properly and has not been connected or paired by others; Check if the Bluetooth and network conditions of the cell phone are good.	Reset the device Bluetooth and restart the app then try to connect again.
The device is no longer searchable after removing it from the APP.	Check if the device have been removed while it is off-lined or in poor network conditions.	Reset the device Bluetooth and then search again to add the device.
In-app device controls can not be accessed.	Check if the device is online; If it's off-line, please advice to the Distribution Network Connection Failure steps.	Reboot the device, wait for 5 seconds, wait till it shows as online status. To control it; Reset the device Bluetooth and then add the device back to the device list.

USE AND PRESERVATION

Do not place the product in a high humidity, strong electromagnetic field, direct sunlight, or high-temperature environment. If the product will not be used for a long time, please disconnect its power.

Cleaning: Unplug the power before cleaning. Use a dry cloth only—avoid cleaning agents or solventbased liquids, as they may damage the surface.

Power: Make sure the power is within the demanded range, not too high or too low.

Repairing: If there is a fault or performance degradation, do not unpack the shell by yourself, avoiding damage to the machine and losing the right of maintenance. When there is a fault, do not hesitate to contact us, and we will do our best to deal with the problem.

Accessories: Please use the accessories provided by the manufacturer and approved ones, to maximize the performance.

Warranty: Do not modify the product, or you will lose the right to maintenance.

PACKING LIST

Name	Quantity	Notes
LED Video Lights	1	
Power Cord	1	
Lamp head protective cover	1	
Carrying Case	1	

PRODUCT WARRANTY

Dear user, this warranty card is important proof for applying for warranty service. Please cooperate with the salesperson to fill it out and keep it properly. Thank you!

Product Information	Model Number	Product Barcode
User Information	Name	Contact Number
	Mailing Address	
Seller Information	Name	
	Contact Number	
	Mailing Address	
	Sales Date	
Remarks		

Note: this form should be confirmed by the salesperson's stamp.

Applicable Products

This document applies to the products listed in the relevant "Product Warranty Information" (see instructions below). Other products or components that do not fall within this scope (such as promotional products, gift items, and other components added after the factory) are not covered by this warranty promise.

Warranty Period

The corresponding warranty period for products and components shall be executed according to the relevant "Product Warranty Information". The warranty period starts from the first day of purchase of the product, and the date of registration on the warranty card at the time of purchase shall prevail.

How to Obtain Warranty Service

You can directly contact the product salesperson or authorized service agency, or call GVM's after-sales service hotline to contact us and have our service personnel arrange service for you. When applying for warranty service, you should provide a valid warranty card as a warranty certificate to be eligible for warranty service. If you cannot provide a valid warranty card, we may also provide you with warranty service under the circumstance that our products or components are confirmed to be within the warranty scope, but this is not our obligation.

Cases where warranty does not apply:

If the product meets the following conditions, the warranty and service under this document will not apply:

1. The product or parts have exceeded the corresponding warranty period.
2. Malfunctions or damages caused by incorrect or improper use, maintenance, or storage, such as improper handling, use for purposes other than the reasonable expectations of the product, incorrect insertion or removal of external devices, falling or crushing due to external force, or exposure to inappropriate temperature, solvents, acids, alkalis, water immersion, or damp environments.
3. Malfunctions or damages caused by unauthorized installation, repair, modification, addition, or disassembly by institutions or personnel not authorized by GVM.
4. Modifications, changes, or removals of the original identification information of the product or its parts.
5. Lack of valid warranty card.
6. Malfunctions or damages caused by the use of unauthorized, non-standard or non-publicly released software.
7. Malfunctions or damages caused by force majeure or accidents.
8. Other malfunctions or damages not caused by quality issues of the product itself. In such cases, you should seek solutions from the relevant responsible parties, and GVM will not be held liable. Malfunctions or damages caused by components, accessories, or software not covered by the warranty or beyond the warranty scope that renders the product unable to function properly are not covered by the warranty. Fading, wear, and consumption that is normal during the product usage process are not covered by the warranty.

Product Warranty and Service Support Information

The product warranty period and service types are implemented according to the following "Product Warranty Information" for each product category, component, and optional equipment:

Product Category	Accessories Name	Warranty Period(Month)	Warranty Service Type
Component	Circuit Board.	12 Month	Customer service repair
Other	Spotlight mount, softbox, adapter, Standard reflector, power cord, battery Handle, light stand, TYPE-C cable, battery slot, battery, Fresnel lens, grid, carrying bag and all other accessories, etc. Consumable or electrically sensitive parts are not covered by the warranty.	None	No Warranty

QC
PASS



GVM Official website



Facebook



Download APP

Huizhou Latu Film Equipment Co., Ltd.

Web: www.gvmlcd.com

B&H Email: bh@gvmlcd.com

GVM Email: support@gvmlcd.com

Amazon Email: amazonsupport@gvmlcd.com

Warehouse Address: 12285 MCNULTY RD, STE 105 PHILADELPHIA, Pennsylvania 19154, USA