



CAUTION READ
THIS MANUAL CAREFULLY TO DIAGNOSE
TROUBLE CORRECTLY BEFORE OFFERING
SERVICE.

SERVICE MANUAL

Colour Television

Haier model:
21FA11-AM
Customer model:
HTAF21S

CONTENTS

1. Safety precautions.....	3
2. TV block diagram.....	4
3. Replacement of memory IC.....	5
4. Service adjustment.....	5
5. ICs functional description.....	8
6. Test point waveform.....	10
7. All ICs voltages.....	10
8. Purity / convergence adjustment.....	11

1. SAFETY

- The design of this product contains special hardware, many circuits and components especially for safety purposes. For continued protection, no changes should be made to the original design unless authorized in writing by the manufacturer. Replacement parts must be identical to those used in the original circuits. Service should be performed by qualified personnel only.
- Alterations of the design or circuitry of the products should not be made. Any design alterations or additions will void the manufacturer's warranty and will further relieve the manufacturer of responsibility for personal injury or property damage resulting therefrom.
- Many electrical and mechanical parts in the products have special safety-related characteristics. These characteristics are often not evident from visual inspection nor can the protection afforded by them necessarily be obtained by using replacement components rated for higher voltage, wattage, etc. Replacement parts which have these special safety characteristics are identified in the parts list of Service manual. Electrical components having such features are identified by shading on the schematics and by (!) on the parts list in Service manual. The use of a substitute replacement which does not have the same safety characteristics as the recommended replacement part shown in the parts list of Service manual may cause shock, fire, or other hazards
- Don't short between the LIVE side ground and ISOLATED (NEUTRAL) side ground or EARTH side ground when repairing.** Some model's power circuit is partly different in the GND. The difference of the GND is shown by the LIVE: (⚡) side GND, ISOLATED (NEUTRAL): (⊥) side GND and EARTH: (⊕) side GND. Don't short between the LIVE side GND and ISOLATED (NEUTRAL) side GND or EARTH side GND and never measure with a measuring apparatus (oscilloscope etc.) the LIVE side GND and ISOLATED (NEUTRAL) side GND or EARTH side GND at the same time. If above note will not be kept, a fuse or any parts will be broken.
- If any repair has been made to the chassis, it is recommended that the B1 setting should be checked or adjusted (See ADJUSTMENT OF B1 POWER SUPPLY).
- The high voltage applied to the picture tube must conform to that specified in Service manual. Excessive high voltage can cause an increase in X-Ray emission, arcing and possible component damage, therefore operation under excessive high voltage conditions should be kept to a minimum, or should be prevented. If severe arcing occurs, remove the AC power immediately and determine the cause by visual inspection (incorrect installation, cracked or melted high voltage harness, poor soldering, etc.). To maintain the proper minimum level of soft X-Ray emission, components in the high voltage circuitry including the picture tube must be the exact replacements or alternatives approved by the manufacturer of the complete product.
- Do not check high voltage by drawing an arc. Use a high voltage meter or a high voltage probe with a VTVM. Discharge the picture tube before attempting meter connection, by connecting a clip lead to the ground frame and connecting the other end of the lead through a 10kΩ 2W resistor to the anode button.
- When service is required, observe the original lead dress. Extra precaution should be given to assure correct lead dress in the high voltage circuit area. Where a short circuit has occurred, those components that indicate evidence of overheating should be replaced. Always use the manufacturer's replacement components.

PRECAUTIONS

- Isolation Check
(Safety for Electrical Shock Hazard)
After re-assembling the product, always perform an isolation check on the exposed metal parts of the cabinet (antenna terminals, video/audio input and output terminals, Control knobs, metal cabinet, screw heads, earphone jack, control shafts, etc.) to be sure the product is safe to operate without danger of electrical shock.
 - The surface of the TV screen is coated with a thin film which can easily be damaged. Be very careful with it when handle the TV. Should the TV screen become soiled, wipe it with a soft dry cloth. Never rub it forcefully. Never use any cleaner or detergent on it.
- (1) Dielectric Strength Test**
The isolation between the AC primary circuit and all metal parts exposed to the user, particularly any exposed metal part having a return path to the chassis should withstand a voltage of 3000V AC (r.m.s.) for a period of one second. (...Withstand a voltage of 1100V AC (r.m.s.) to an appliance rated up to 120V, and 3000V AC (r.m.s.) to an appliance rated 200V or more, for a period of one second.) This method of test requires test equipment not generally found in the service trade.
 - (2) Leakage Current Check**
Plug the AC line cord directly into the AC outlet (do not use line isolation transformers during this check). Using a "Leakage Current Tester", measure the leakage current from each exposed metal part of the cabinet, particularly any exposed metal part having a return path to the chassis, to a known good earth ground (water pipe, etc.). Any leakage current must not exceed 0.5mA AC (r.m.s.). However, in tropical area, this must not exceed 0.2mA AC (r.m.s.).
 - Alternate Check Method
Plug the AC line cord directly into the AC outlet (do not use a line isolation transformer during this check.). Use an AC voltmeter having 1000 ohms per volt or more sensitivity in the following manner. Connect a 1500Ω 10W resistor paralleled by a 0.15μF AC-type capacitor between an exposed metal part and a known good earth ground (water pipe, etc.). Measure the AC voltage across the resistor with the AC voltmeter. Move the resistor connection to each exposed metal part, particularly any exposed metal part having a return path to the chassis, and measure the AC voltage across the resistor. Now, reverse the plug in the AC outlet and repeat each measurement. Any voltage measured must not exceed 0.75V AC (r.m.s.). This corresponds to 0.5mA AC (r.m.s.). However, in tropical area, this must not exceed 0.3V AC (r.m.s.). This corresponds to 0.2mA AC (r.m.s.)

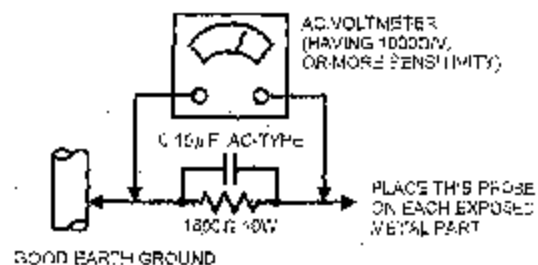

2. Block diagram TDA8378PS/N2 series with mono intercarrier sound demodulator

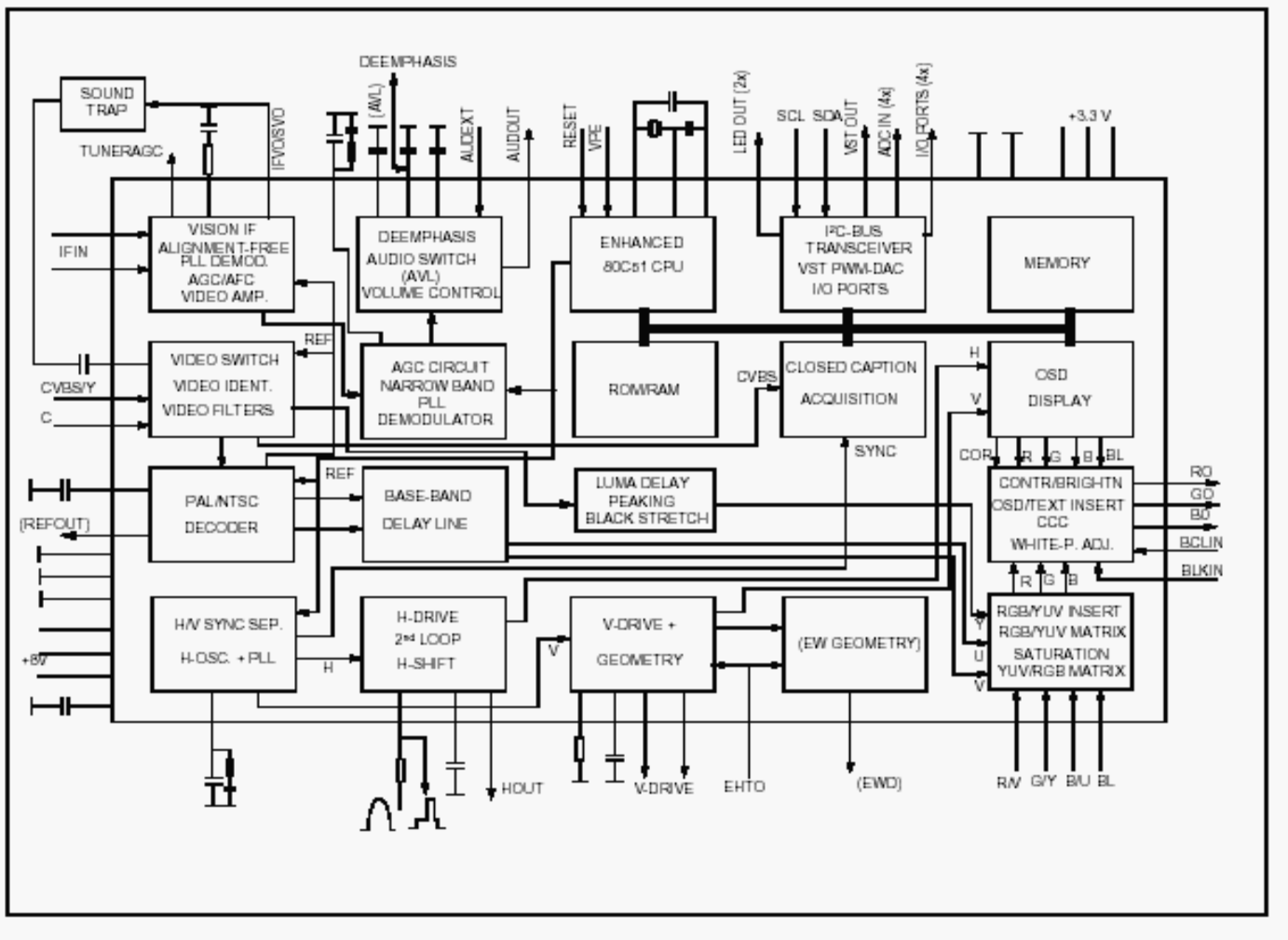

BLOCK DIAGRAM

3. REPLACEMENT OF MEMORY IC

1. MEMORY IC.

This TV uses memory IC. In the memory IC are memorized data for correctly operating the video and deflection circuits.

2. PROCEDURE FOR REPLACING MEMORY IC

- (1) Power off
Switch the power off and unplug the power cord from AC outlet.
- (2) Replace IC
Be sure to use memory IC written with the initial data values.
- (3) Power On
Plug the power cord into the AC outlet and switch the power on.
- (4) Check and set SYSTEM default value:
 - 1) Press "MUTE" "CALL" "-\--" "CALL" "MUTE" buttons in sequence to enter into factory status.
 - 2) If the memory IC haven't been written with the initial data, press [Program+] / [Program-] to select item INIT and press [VOLUME+] / [VOLUME-] to start initialize memory IC.
 - 3) Check the setting value of the SYSTEM default value of Table below. If the value is different, select items by [Program+] / [Program-] keys and set value by [VOLUME+] / [VOLUME-] keys.
 - 4) Press "EXIT" button to return to the normal screen.

4. SERVICE ADJUSTMENT

Specific operation: use remote controller

Press "MUTE" "CALL" "-\--" "CALL" "MUTE" buttons in sequence to enter into factory mode.

Press [Program+] / [Program-] to select items and press [VOLUME+] / [VOLUME-] key, to make data adjustment of corresponding factory menus.

Press "EXIT" key to exit factory mode.

Focus adjustment

1. Receive a crosshatch signal.
2. While watching the screen, adjust the FOCUS VR on the FBT to make the vertical and horizontal lines as fine and sharp as possible.

Geometrical adjustment

Receive PAL standard complete pattern signal.

Adjustment steps:

- a) Adjust VSL, to the centre horizontal line just appears from half bottom shadow.
- b) Adjust VAM, to get 92% of vertical picture contents would be displayed on CRT.
- c) Adjust VSH, the centre horizontal line corresponds to CRT vertical centre.
- d) Adjust SCL, to the linearity of P card field is in proper condition.
- e) Adjust HSH, to get the picture horizontal centre correspond to CRT horizontal centre.

Receive NTSC signal and repeat above adjustment.

AGC Adjustment

Receive 60dB μ (1mV) VH colour bar pattern signal.

Select TOP item.

Adjust value, to noise reduce gradually and just disappeared point.

CRT cut off and white balance adjustment

- a) CRT cut off adjustment
 1. Select item VG2B, then adjust value to 32.
 2. PRESS "0" key, when the screen shows "VG2" adjust the SCREEN control on Fly back transformer to make the screen show alternating flashing characters of "INSIDE HIGH INSIDE LOW".
- b) White balance adjustment
 1. Receive a Black and White pattern.
 2. Adjust WRP, WRG, WRB items to get colour temperature 9300K \pm 3 JND.

Adjustable Items

Direct access key	Items	Description	Preset	Remark
"1"	5/6HSH	Horizontal shift	ON	A
"2"	5/6VSL	Vertical slop	32	A
	5/6VAM	Vertical amplitude	23	A
	5/6SCL	S-correction	17	A
	5/6VSH	Vertical shift	27	A
	5/6VOF	OSD Vertical offset	37	A
	HOF*	OSD Horizontal offset	42	A
"3"	RED	Black level offset R	32	A
	GRN	Black level offset G	32	A
	WPR	White point R	30	A
	WPG	White point G	26	A
	WPB	White point B	38	A
"4"	TOP	AGC Take-over point	20	A
	VOL	Volume	42	
	9860	Sub-volume of TDA9860/59	18	
	HDOL	Cathode drive level	59	
	AGC	IF AGC speed	1	
	VG2B	VG2 Brightness	42	
	IFFS		2	
"5"	Picture preset 1			
	0CON	Listen: Contrast	0	A
	0BRI	Listen: Brightness	0	A
	0COL	Listen: Colour	50	A
	0SHP	Listen: Sharpness	50	A
	1CON	Soft: Contrast	45	A
	1BRI	Soft: Brightness	45	A
	1COL	Soft: Colour	50	A
	1SHP	Soft: Sharpness	50	A
"6"	Picture preset 2			
	2CON	Standard: Contrast	75	A
	2BRI	Standard: Brightness	50	A
	2COL	Standard: Colour	50	A
	2SHP	Standard: Sharpness	60	A
	3CON	Dynamic: Contrast	85	A
	3BRI	Dynamic: Brightness	60	A
	3COL	Dynamic: Colour	60	A
	3SHP	Dynamic: Sharpness	80	A

NOTE: THE ITEMS WITH REMARK "A" IS ADJUSTABLE DATA.

Optional data

1. OP1

Bit	Function	Description	Preset	Remark
Bit 0	VG2_MODE	1=	0	EA
Bit 1	YPRPB	1=Enable	1	EA
Bit 2	SUPERWOOFER	Translucence OSD manual 1=Enable	0	EA
Bit 3	WOOFER_VOL	1=Enable (Can only be selected either RGB and DVD)	0	EA
Bit 4	AV2	1=Enable	1	EA
Bit 5	SVHS	1=Enable	0	EA
Bit 6	DVD	1=Enable	0	EA
Bit 7	RGB	1=Enable	1	EA

2. OP2

Bit	Function	Description	Preset	Remark
Bit 7	FSL	1=21dB μ V 0=26dB μ V	0	EA
Bit 6	SOY	1=Enable	1	EA
Bit 5	ARABIC_SET	1=Enable	0	EA
Bit 4	FARSI_SET	1=Enable	0	EA
Bit 3	CYRILLIC_SET		0	EA
Bit 2	EUROUP_SET	1=Enable	1	EA
Bit 1	AUTO_SOUND		1	EA
Bit 0	AVL	1=Enable	1	EA

3. OP3

Bit	Function	Description	Preset	Remark
Bit 7	RUSSIA	1=Enable	0	EA
Bit 6	ITALY	1=Enable	0	EA
Bit 5	GERMANY	1=Enable	0	EA
Bit 4	FRANCE	1=Enable	0	EA
Bit 3	RUTKISH	1=Enable	0	EA
Bit 2	ARABIC	1=Enable	0	EA
Bit 1	FARSI	1=Enable	0	EA
Bit 0	ENGLISH	1=Enable	1	EA

4. OP4

Bit	Function	Description	Preset	Remark
Bit 6	HALFTONE	1=Enable	1	EA
Bit 5	IDENT_SENSITIVE		1	EA
Bit 4	HCO	1=Enable	0	EA
Bit 3	LOGO		1	EA
Bit 2	TILT		0	EA
Bit 1	SPANISH		1	EA
Bit 0	ROMANIA		0	EA

5. OP5

Bit	Function	Description	Preset	Remark
Bit 7	STORE_AV	1= Enable	1	EA
Bit 6	OSO	1= Enable	0	EA
Bit 5	SOFR_CHANGE	1=Enable	0	EA
Bit 4	FADE	1=Enable	0	EA
Bit 3	SOUND_M	1= Enable	0	EA
Bit 2	SOUND_I	1= Enable	0	EA
Bit 1	SOUND_BG	1=Enable With DVD select 1	1	EA
Bit 0	SOUND_DK	1=Enable	0	EA

6. OP6

Bit	Function	Description	Preset	Remark
Bit 7	RESERVE	1=Enable	0	EA
Bit 6	POR_WHEN_BLUE	1=Enable	1	EA
Bit 5	MENU_MIDLINE	1=Enable	1	EA
Bit 4	MENU_BLUE	1=Enable	1	EA
Bit 3	CHILDLOCK	1=Enable	1	EA
Bit 2	16_9	1=Enable	0	EA
Bit 1	BLUE_SCREEN	1=Enable	1	EA
Bit 0	LOGO_LISTEN		1	EA

7. OP7

Bit	Function	Description	Preset	Remark
Bit 7	FMWS	1=Enable	1	EA
Bit 6	HOTEL	1=Enable	0	EA
Bit 5	PROG_ID	1=Enable	0	EA
Bit 4	LED	1=Enable	0	EA
Bit 3	TWIST	1=Enable	0	EA
Bit 2	BYELORUSSIAN	1=Enable	0	EA
Bit 1	UKRANIAN	1=Enable	0	EA
Bit 0	AV1	1=Enable	1	EA

8. OP8

Bit	Function	Description	Preset	Remark
Bit 6	DIRECT_SWITCH_ON	1=Enable	0	EA
Bit 5	INNER_DVD	1=Enable	1	EA
Bit 4	PROG_FREQ	1=Enable	0	EA
Bit 3	FAST_BAR	1=Enable	1	EA
Bit 2	AUSTRALIA	1=Enable	0	EA
Bit 1	FREQ	1=Enable	1	EA
Bit 0	9860	1=Enable	0	EA

Note: Don't adjust any OPTION items, please inform the engineer about any change.

5. ICs functional description

1. N201 UOC OM8378

SYMBOL	PIN	DESCRIPTION
STAND BY output.	1	In STAND BY mode, low level (Power OFF). For Power ON this pin will be high.
SCL	2	I ² C-bus clock line
SDA	3	I ² C-bus data line
TUNING	4	tuning Voltage (Vt) PWM output
KEY	5	Control keys input
SYSTEM	6	TV system control
VOL	7	Sound Volume control PWM output
MUTE	8	Sound mute output
VSSC/P	9	Digit ground for μ -controller core and periphery
CTL	10	DVD power control
STANDBY	11	STANDBY control
VSSA	12	Analog ground of digital ground of TV-processor
SECPLL	13	Internally connected
VP2	14	2 nd supply voltage TV-processor(+8V)
DECDIG	15	decoupling digital supply of TV-processor
PH2LF	16	Phase-2 filter
PH1LF	17	Phase-1 filter
GND3	18	Ground 3 for TV-processor
DECDBG	19	Band gap decoupling
AVL/EWD	20	Automatic volume levelling
VDRB	21	Vertical drive B output
VDRA	22	Vertical drive A output
IFIN1	23	IF input 1
IFIN2	24	IF input 2

IREF	25	Reference current input
VSC	26	Vertical sawtooth capacitor
TUNER AGC	27	Tuner AGC output
AUDEEM/SIFIN1 *1	28	Audio deemphasize or SIF input
DECSDEM/SIFIN2	29	Decoupling sound demodulator
GND2	30	Ground 2 for TV processor
SNDPLL/SIFAGC *1	31	Narrow band PLL filter
AVL	32	Automatic Volume Levelling
HOUT	33	Horizontal output
FBISO	34	Flyback input/sandcastle output
AUDEXT	35	External audio output
EHTO	36	EHT/over voltage protection input
PLL IF	37	IF-PLL loop filter
IFVO/SVO	38	IF video output / selected CVBS output
VP1	39	supply voltage TV processor
CVBS INT	40	internal CVBS input
GND1	41	ground for TV processor
CVBS/Y	42	CVBS/SVHS(Y) input
CHROMA	43	SVHS (C) input
AUDOUT	44	Audio output
INSSW2	45	YUV insertion input
R2/VIN	46	R input / V (R-Y) input / PR input
G2/YIN	47	G input / Y input
B2/UIIN	48	B input / U (B-Y) input / PB input
BCLIN	49	Beam current limiter input
BLKIN	50	Black current input
RO	51	Red output
GO	52	Green output
BO	53	Blue output
VDDA	54	Analog supply of Closed Caption decoder and digital supply of TV-processor (3.3 V)
VPE	55	Ground
VDDC	56	Digital supply to core (3.3 V)
OSCGND	57	Oscillator ground supply
XTALIN	58	Crystal oscillator input
XTALOUT	59	Crystal oscillator output
RESET	60	Ground
VDDP	61	Digital supply to periphery (+3.3 V)
P1.0/INT1	62	AV1 / AV2 mode Output.
P1.1/T0	63	AV /S-VHS mode Output.
P1.2/INT0	64	Remote control signal input.

Note

Pin	TV	SVHS	AV1	AV2
62	1	0	0	1
63	1	1	0	0

2. N202 24C08/PCF8598

PIN	Function
1	GND
2	GND
3	Upper resistance
4	GND
5	SDA data wire
6	SCL clock wire
7	GND
8	+5V Power

3. N601: Sound power amplify (AN7522N)

Symbol	PIN	Function	Symbol	PIN	Function
Vcc	1	Power supply	GND	7	ground
Out 1 (+)	2	Ch 1 output (+)	In 2	8	Ch 2 input
GND(out 1)	3	Ch 1Ground	VOL	9	Volume Control
Out 1 (-)	4	Ch 1 output (-)	Out 2 (-)	10	Ch 2 output (-)
Standby	5	Mute input	GND(out 2)	11	Ch 2 Ground

In 1	6	Ch 1 input	Out 2 (+)	12	Ch 2 output (+)
------	---	------------	-----------	----	-----------------

4. N301: Vertical output (TDA8357A)

Symbol	PIN	Function	Symbol	PIN	Function
INV IN	1	Input	PUMP UP	6	Pump up power
INV IN	2	Input	V OUT	7	Vertical output
Vcc	3	Pump up power	V PRO	8	Vertical protection
V OUT	4	Vertical output	V FEEDBACK	9	Vertical feedback
GND	5	Ground			

5. U101: Tuner

PIN	Function	PIN	Function
1	AGC	7	+5V
2	vacant	8	vacant
3	Gnd	9	Vt 33V
4	SCL	10	Gnd
5	SDA	11	IF Out
6	+5V		

6. Test point Waveforms

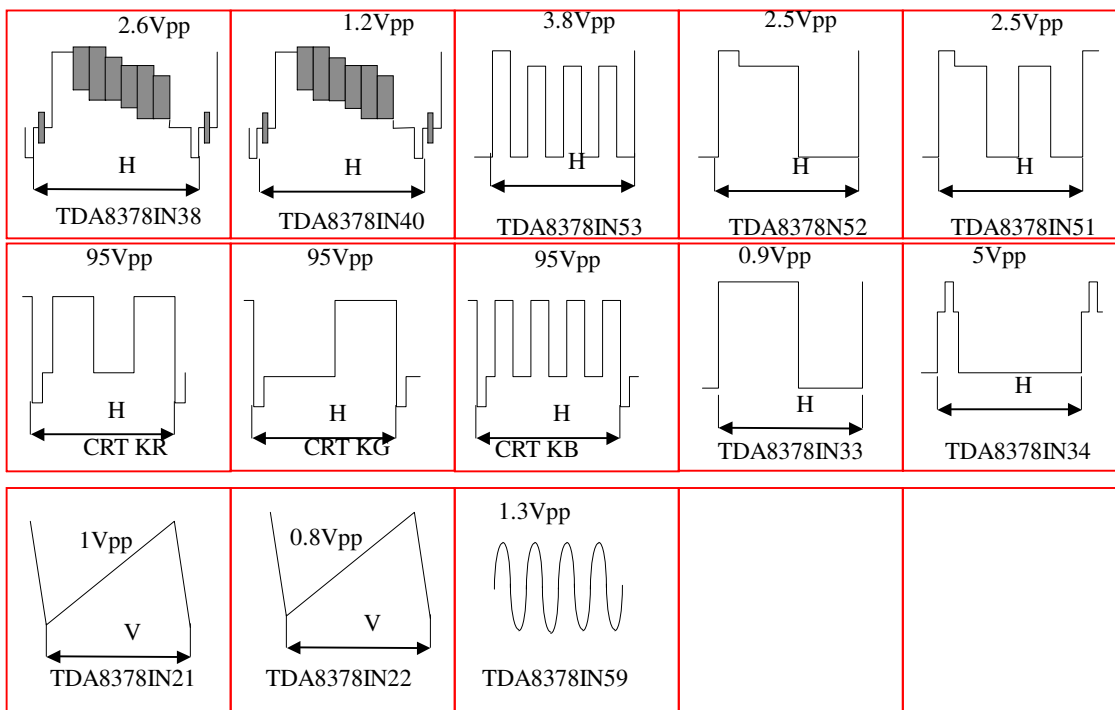

7. IC voltages

TDA8378

PIN	1	2	3	4	5	6	7	8	9	10	11	12	13	14	15	16
V	0	3.8	3.6	3.3	3.5	4.4	5.1	1.8	0	0.18	0.17	0	2.3	8	5	3
PIN	17	18	19	20	21	22	23	24	25	26	27	28	29	30	31	32
V	4	0	4	0.5	0.7	0.8	1.9	1.9	3.9	3.8	1.6	3.2	2.3	0	2.3	0.2
PIN	33	34	35	36	37	38	39	40	41	42	43	44	45	46	47	48
V	0.5	0.3	0	1.7	2.4	3.4	8	3.9	0	3.3	0	3.6	1.4	2.5	2.5	2.5
PIN	49	50	51	52	53	54	55	56	57	58	59	60	61	62	63	64
V	1.9	5.0	2.4	2.4	2.4	3.1	0	3.2	0	1.8	1.7	0	3.2	5.1	3.3	5

TDA8357

PIN	1	2	3	4	5	6	7	8	9
V	0.8	0.7	16	6.9	0	43	7.2	0.3	7.2

AN 7522N

PIN	1	2	3	4	5	6	7	8	9	10	11	12	
V	10	4.4	0	4.4	2.75	1.4	0	1.4	0.35	4.4	0	4.4	

24C08/PCF8598

PIN	1	2	3	4	5	6	7	8
V	0	0	5.1	0	3.2	0	0	5.1

8. PURITY / CONVERGENCE ADJUSTMENT

PURITY ADJUSTMENT

1. Demagnetize CRT with the demagnetizer.
2. Loosen the retainer screw of the deflection yoke.
3. Remove the wedges.
4. Input a green raster signal from the signal generator, and turn the screen to green raster.
5. Move the deflection yoke backward.
6. Bring the long lug of the purity magnets on the short lug and position them horizontally. (Fig2)
7. Adjust the gap between two lugs so that the GREEN RASTER will come into the centre of the screen. (Fig. 3)
8. Move the deflection yoke forward, and fix the position of the deflection yoke so that the whole screen will become green.
9. Insert the wedge to the top side of the deflection yoke so that it will not move.
10. Input a crosshatch signal.
11. Verify that the screen is horizontal.
12. Input red and blue raster signals, and make sure that purity is properly adjusted.

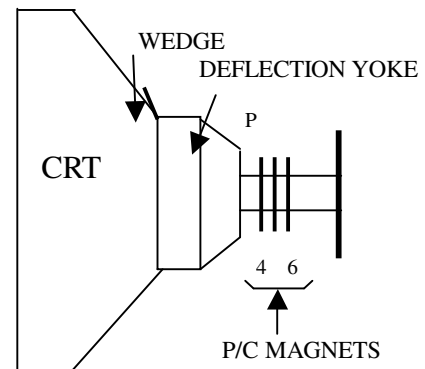

P: PURITY MAGNET
 4: 4-POLES (convergence magnets)
 6: 6-POLES (convergence magnets)

Fig. 1

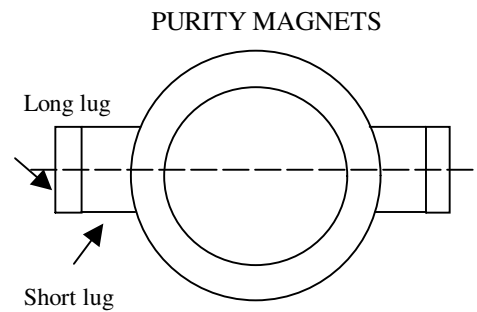

Bring the long lug over the short lug and position them horizontally.

Fig. 2

(FRONT VIEW)

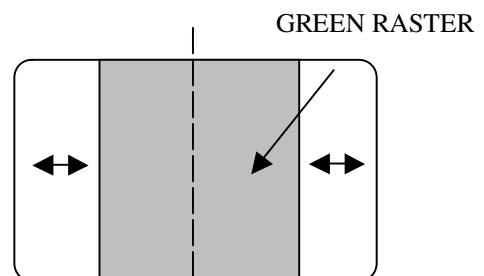

CENTER

Fig. 3

STATIC CONVERGENCE ADJUSTMENT

1. Input a crosshatch signal.
2. Using 4-pole convergence magnets overlap the red and blue lines in the center of the screen (Fig. 1) and turn them to magenta (red/blue).
3. Using 6-pole convergence magnets overlap the magenta (red/blue) and green lines in the center of the screen and turn them to white.
4. Repeat 2 and 3 above, and make the best convergence.

DYNAMIC CONVERGENCE ADJUSTMENT

1. Move the deflection yoke up and down and overlap lines in the periphery. (Fig. 2)
2. Move the deflection yoke left to right and overlap the lines in the periphery. (Fig. 3)
3. Repeat 1 and 2 above, and make the best convergence.

After adjustment, fix the wedge at the original position.
Fasten the retainer screw of the deflection yoke.
Fix the 6 magnets with glue.

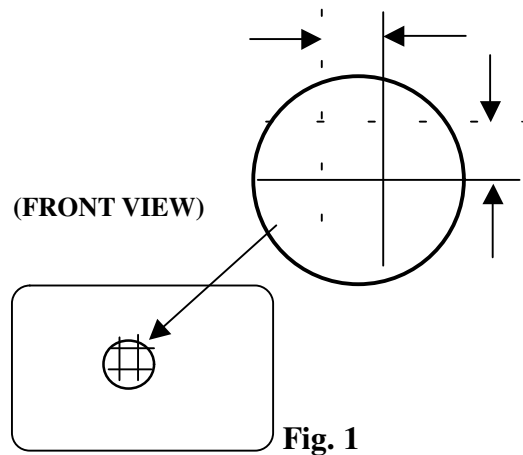

(FRONT VIEW)

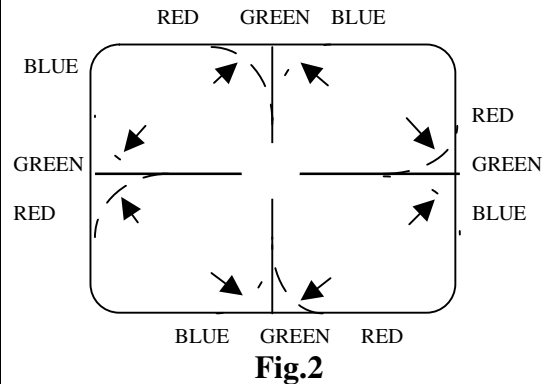

(FRONT VIEW)

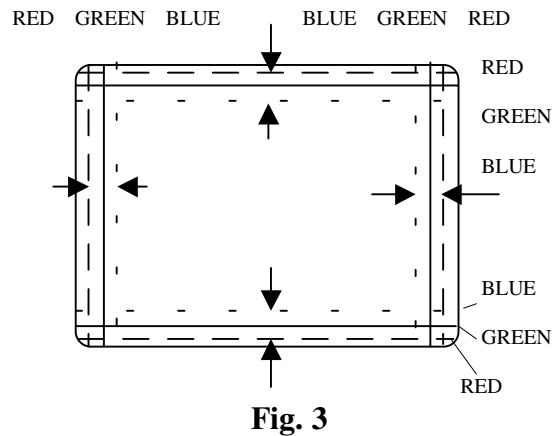

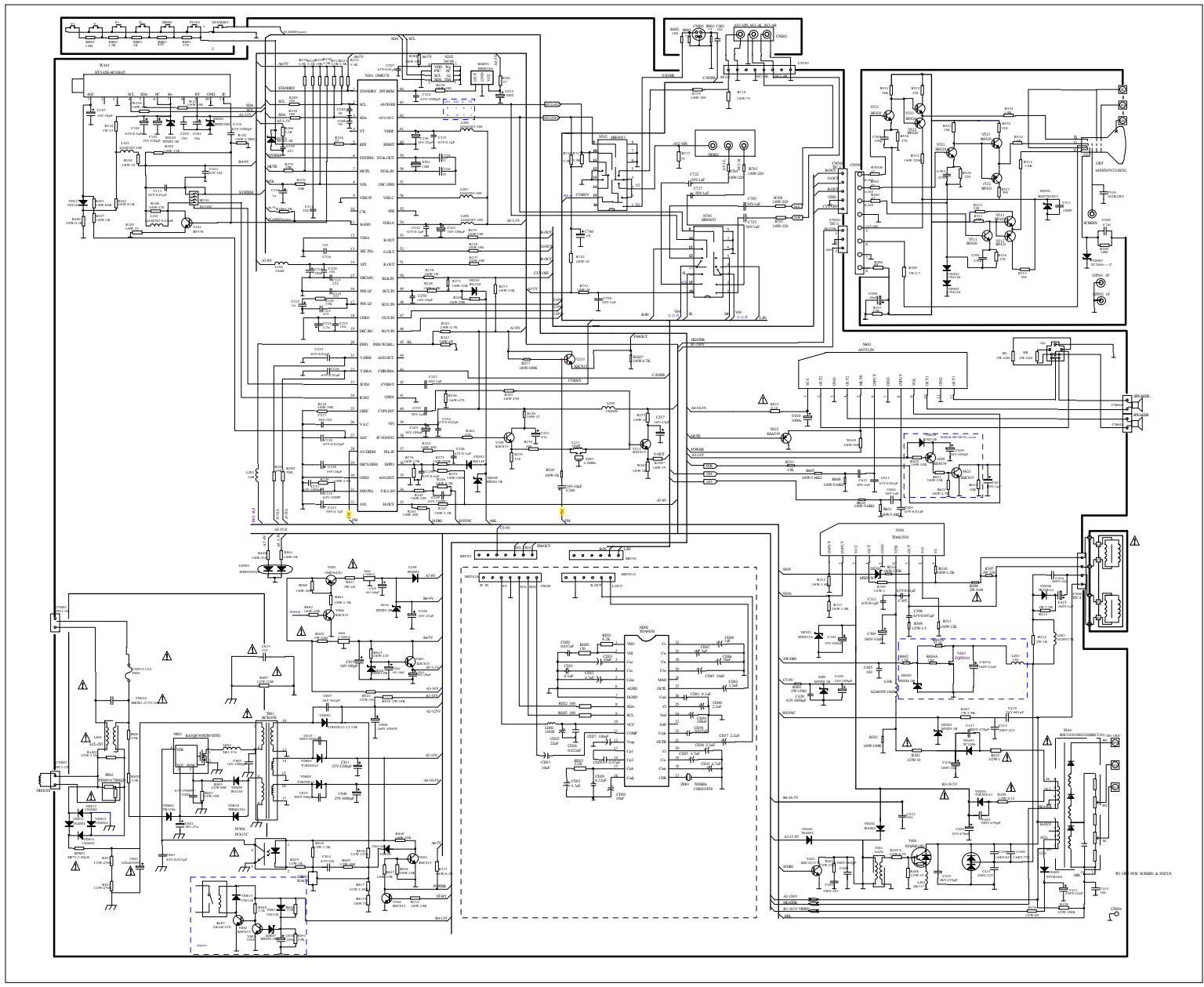

Sincere Forever
