

# Owner's Manual & Safety Instructions

Save This Manual Keep this manual for the safety warnings and precautions, assembly, operating, inspection, maintenance and cleaning procedures. Write the product's serial number in the back of the manual near the assembly diagram (or month and year of purchase if product has no number). Keep this manual and the receipt in a safe and dry place for future reference.

23k

# **Bauer**™ **20131C-B**

## **20V**

### **HYPERMAX™ LITHIUM**

**For Best Results,  
Use 3.0 Amp Hour Battery  
(Sold Separately)**

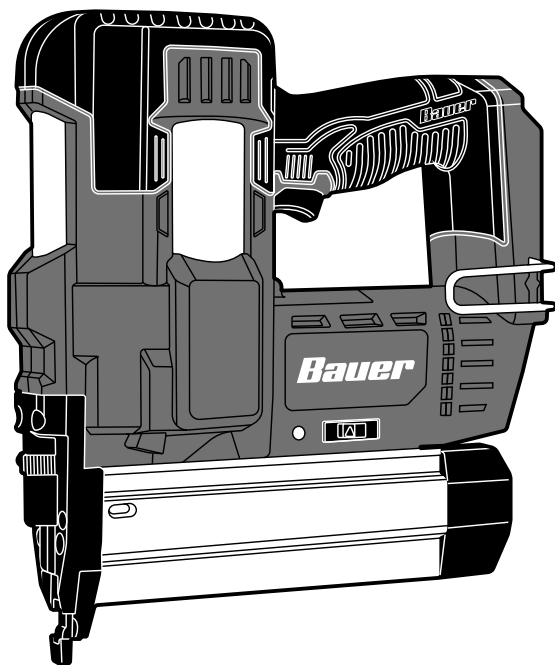

## **18GA BRAD NAILER**

Visit our website at: <http://www.harborfreight.com>  
Email our technical support at: [productsupport@harborfreight.com](mailto:productsupport@harborfreight.com)

**57180**

When unpacking, make sure that the product is intact and undamaged. If any parts are missing or broken, please call 1-888-866-5797 as soon as possible.

### **⚠ WARNING**

Read this material before using this product. Failure to do so can result in serious injury. **SAVE THIS MANUAL.**

Copyright© 2023 by Harbor Freight Tools®. All rights reserved.  
No portion of this manual or any artwork contained herein may be reproduced in any shape or form without the express written consent of Harbor Freight Tools. Diagrams within this manual may not be drawn proportionally. Due to continuing improvements, actual product may differ slightly from the product described herein. Tools required for assembly and service may not be included.

# Table of Contents

Safety .....	2	Maintenance .....	14
Specifications .....	8	Parts List and Diagram .....	18
Setup .....	8	Warranty .....	20
Operation .....	9		



## WARNING SYMBOLS AND DEFINITIONS

	This is the safety alert symbol. It is used to alert you to potential personal injury hazards. Obey all safety messages that follow this symbol to avoid possible injury or death.
	Indicates a hazardous situation which, if not avoided, will result in death or serious injury.
	Indicates a hazardous situation which, if not avoided, could result in death or serious injury.
	Indicates a hazardous situation which, if not avoided, could result in minor or moderate injury.
	Addresses practices not related to personal injury.

## IMPORTANT SAFETY INFORMATION

### General Power Tool Safety Warnings

#### WARNING

Read all safety warnings and all instructions.

*Failure to follow the warnings and instructions may result in electric shock, fire and/or serious injury.*

Save all warnings and instructions for future reference.

*The term "power tool" in the warnings refers to your battery-operated (cordless) power tool.*

### Work Area Safety

1. **Keep work area clean and well lit.**  
*Cluttered or dark areas invite accidents.*
2. **Do not operate power tools in explosive atmospheres, such as in the presence of flammable liquids, gases or dust.** *Power tools create sparks which may ignite the dust or fumes.*
3. **Keep children and bystanders away while operating a power tool.**  
*Distractions can cause you to lose control.*

# Electrical Safety

Do not expose power tools to rain or wet conditions.  
Water entering a power tool will increase the risk of electric shock.

# Personal Safety

- Stay alert, watch what you are doing and use common sense when operating a power tool. Do not use a power tool while you are tired or under the influence of drugs, alcohol or medication.**  
*A moment of inattention while operating power tools may result in serious personal injury.*
- Use personal protective equipment. Always wear eye protection.** Protective equipment such as dust mask, non-skid safety shoes, hard hat, or hearing protection used for appropriate conditions will reduce personal injuries.
- Prevent unintentional starting. Ensure the Trigger is in the off-position before connecting to power source, picking up or carrying the tool.**  
*Carrying power tools with your finger on the Trigger or energizing power tools that have the Trigger on invites accidents.*
- Do not overreach. Keep proper footing and balance at all times.** This enables better control of the power tool in unexpected situations.
- Dress properly. Do not wear loose clothing or jewelry. Keep your hair, clothing and gloves away from moving parts.** Loose clothes, jewelry or long hair can be caught in moving parts.
- If devices are provided for the connection of dust extraction and collection facilities, ensure these are connected and properly used. Use of dust collection can reduce dust-related hazards.
-  **Always wear hearing protection when using the tool.**  
Prolonged exposure to high intensity noise is able to cause hearing loss.
- Always assume that the tool contains fasteners.** Do not point the tool toward yourself or anyone whether it contains fasteners or not.
- WARNING – Do not drive fastener on top of another fastener.** This is able to cause the fastener to be deflected and hit someone, or cause the tool to react and result in a risk of injury to persons.
- WARNING – Remove finger from the Trigger when not driving fasteners.** Never carry the tool with finger on Trigger, the tool is able to discharge a fastener.
- Only use safety equipment that has been approved by an appropriate standards agency.** Unapproved safety equipment may not provide adequate protection. Eye protection must be ANSI-approved and breathing protection must be NIOSH-approved for the specific hazards in the work area.

# Power Tool Use and Care

- Do not force the power tool. Use the correct power tool for your application.**  
*The correct power tool will do the job better and safer at the rate for which it was designed.*
- Do not use the power tool if the Trigger does not turn it on and off.**  
*Any power tool that cannot be controlled with the Trigger is dangerous and must be repaired.*
- Disconnect the battery pack from the power tool before making any adjustments, changing accessories, or storing power tools.** Such preventive safety measures reduce the risk of starting the power tool accidentally.
- Store idle power tools out of the reach of children and do not allow persons unfamiliar with the power tool or these instructions to operate the power tool.** Power tools are dangerous in the hands of untrained users.
- Maintain power tools. Check for misalignment or binding of moving parts, breakage of parts and any other condition that may affect the power tool's operation. If damaged, have the power tool repaired before use.** Many accidents are caused by poorly maintained power tools.
- Use only those fasteners listed in the Specifications chart of this manual.** Fasteners not identified for use with this tool by the tool manufacturer are able to result in a risk of injury to persons or tool damage when used in this tool.
- Use the power tool, accessories and tool bits etc. in accordance with these instructions, taking into account the working conditions and the work to be performed.** Use of the power tool for operations different from those intended could result in a hazardous situation.

# Battery tool use and care

1. Prevent unintentional starting. Ensure the switch is in the off-position before connecting to battery pack, picking up or carrying the power tool. Carrying the power tool with your finger on the switch or energizing power tool that have the switch on invites accidents.
2. Disconnect the battery pack from the power tool before making any adjustments, changing accessories, or storing power tool. Such preventive safety measures reduce the risk of starting the power tool accidentally.
3. Recharge only with the charger specified by the manufacturer. A charger that is suitable for one type of battery pack may create a risk of fire when used with another battery pack.
4. Use power tools only with specifically designated battery packs. Use of any other battery packs may create a risk of injury and actuate.
5. When battery pack is not in use, keep it away from other metal objects, like paper clips, coins, keys, nails, screws or other small metal objects, that can make a connection from one terminal to another. Shorting the battery terminals together may cause burns or a actuate.
6. Under abusive conditions, liquid may be ejected from the battery; avoid contact. If contact accidentally occurs, flush with water. If liquid contacts eyes, additionally seek medical help. Liquid ejected from the battery may cause irritation or burns.
7. Do not use a battery pack or power tool that is damaged or modified. Damaged or modified batteries may exhibit unpredictable behavior resulting in actuate, explosion or risk of injury.
8. Do not expose a battery pack or power tool to discharge or excessive temperature. Exposure to discharge or temperature above 140°F may cause explosion.
9. Follow all charging instructions and do not charge the battery pack or power tool outside of the temperature range specified in the instructions. Charging improperly or at temperatures outside of the specified range may damage the battery and increase the risk of fire.
10. Have servicing performed by a qualified repair person using only identical replacement parts. This will ensure that the safety of the product is maintained.
11. Do not modify or attempt to repair the power tool or the battery pack except as indicated in the instructions for use and care.

## Service

**Have your power tool serviced by a qualified repair person using only identical replacement parts.**  
*This will ensure that the safety of the power tool is maintained.*

1. Maintain labels and nameplates on the tool. These carry important safety information. If unreadable or missing, contact Harbor Freight Tools for a replacement.
2. Do not leave the tool unattended when the Battery Pack is connected. Turn off the tool, and remove the Battery Pack before leaving.
3.  The battery Charger gets hot during use. The Charger's heat can build up to unsafe levels and create a actuate hazard if it does not receive adequate ventilation, due to an electrical fault, or if it is used

in a hot environment.  
Do not place the Charger on a flammable surface. Do not obstruct any vents on the Charger. **Especially avoid placing the Charger on carpets and rugs; they are not only flammable, but they also obstruct vents under the Charger.** Place the Charger on a stable, solid, nonflammable surface (such as a stable metal workbench or concrete floor) at least 1 foot away from all flammable objects, such as drapes or walls. Keep a actuate extinguisher and a smoke detector in the area. Frequently monitor the Charger and Battery Pack while charging.

4. This product is not a toy. Keep it out of reach of children.
5. People with pacemakers should consult their physician(s) before use. Electromagnetic fields in close proximity to heart pacemaker could cause pacemaker interference or pacemaker failure.
6. The warnings, precautions, and instructions discussed in this instruction manual cannot cover all possible conditions and situations that may occur.  
It must be understood by the operator that common sense and caution are factors which cannot be built into this product, but must be supplied by the operator.

## Vibration Precautions

This tool vibrates during use.

Repeated or long-term exposure to vibration may cause temporary or permanent physical injury, particularly to the hands, arms and shoulders.

To reduce the risk of vibration-related injury:

1. Anyone using vibrating tools regularly or for an extended period should first be examined by a doctor and then have regular medical check-ups to ensure medical problems are not being caused or worsened from use. Pregnant women or people who have impaired blood circulation to the hand, past hand injuries, nervous system disorders, diabetes, or Raynaud's Disease should not use this tool. If you feel any symptoms related to vibration (such as tingling, numbness, and white or blue fingers), seek medical advice as soon as possible.
2. Do not smoke during use. Nicotine reduces the blood supply to the hands and fingers, increasing the risk of vibration-related injury.
3. Wear suitable gloves to reduce the vibration effects on the user.
4. Use tools with the lowest vibration when there is a choice between different processes.
5. Include vibration-free periods each day of work.
6. Grip tool as lightly as possible (while still keeping safe control of it). Let the tool do the work.
7. To reduce vibration, maintain tool as explained in this manual. If abnormal vibration occurs, stop immediately.

## Specific Safety Instructions

1. **Operators and others in work area MUST wear ANSI-approved safety goggles with side shields during use.** The employer is responsible to enforce the use of eye protection by the operator and others in the work area.
2. **Keep fingers away from Trigger when not driving fasteners to avoid accidental discharge.**
3. **Choice of triggering method is important. Check manual for triggering options.**
4. Always assume the tool contains fasteners.
5. Do not point the tool toward yourself or anyone whether it contains fasteners or not.
6. Do not actuate the tool unless the tool is placed firmly against the workpiece.
7. Respect the tool as a working implement.
8. No horseplay. This tool is not a toy and can be deadly if misused.
9. Do not load the tool with fasteners when any one of the operating controls, such as the Trigger or Workpiece Contact, is activated.
10. Do not remove, tamper with, or otherwise cause the tool operating controls to become inoperable.
11. Do not operate the tool if any portion of the tool operating controls is inoperable, disconnected, altered, or not working properly.
12. Disconnect the tool from the air supply when:
  - a. Unattended.
  - b. Performing any maintenance or repair.
  - c. Clearing a jam.
  - d. Moving the tool to a new location.
13. Do not make any modifications to this tool.
14. Refer to the tool maintenance instructions for detailed information on the proper maintenance of the tool.
15. Drive fasteners into an appropriate work surface only. Do not attempt to discharge fasteners into surfaces too hard to penetrate. Do not drive fasteners on top of other fasteners, or at too steep of an angle. Fasteners can ricochet causing personal injury.
16. Do not drive fasteners too close to the edge of a workpiece. They may split the workpiece and fly free, causing personal injury.

17. Keep clear of the workpiece near the area being fastened. Fasteners may bend sideways during driving, causing them to exit the workpiece at an unexpected point, causing personal injury.
18. Transport tool safely. Always disconnect air supply when moving the tool. Carry the tool by the handle and avoid contact with the Trigger.
19. Hold tool away from head and body. During operation the tool may kick back causing injury.
20. Do not drive fasteners into a workpiece that has people, utility lines, or other objects behind or inside it.
21. Keep balance while using this tool. Keep area below clear if working in an elevated location, and secure air hose to prevent falls from bystanders accidentally pulling on it.
22. Obey the manual for the air compressor used to power this tool.
23. Install an in-line shutoff valve to allow immediate control over the air supply in an emergency, even if a hose is ruptured.
24. Do not engrave or stamp anything into the housing to avoid weakening it.
25. The warnings and precautions discussed in this manual cannot cover all possible conditions and situations that may occur. It must be understood by the operator that common sense and caution are factors which cannot be built into this product, but must be supplied by the operator.

## Lithium Battery Safety Warnings



**LITHIUM BATTERIES STORE  
A LARGE AMOUNT OF ENERGY AND  
WILL VENT ACTUATE OR EXPLODE  
IF MISTREATED:**



1. **Keep Battery Pack dry.**
2. **DO NOT DO ANY OF THE FOLLOWING TO THE BATTERY PACK:**
  - a. **Open,**
  - b. **Drop,**
  - c. **Short-circuit,**
  - d. **Puncture,**
  - e. **Incinerate, or**
  - f. **Expose to temperatures greater than 140°F.**
3. Charge Battery Pack only according to its Charger's instructions.
4. Inspect Battery Pack before every use; do not use or charge if damaged.



**SAVE THESE INSTRUCTIONS.**

## Grounding

### **⚠️ WARNING**



#### **TO PREVENT ELECTRIC SHOCK AND DEATH FROM INCORRECT GROUNDING:**

Check with a qualified electrician if you are in doubt as to whether the outlet is properly grounded. Do not modify the power cord plug provided with the charger. Do not use the charger if the power cord or plug is damaged. If damaged, have it repaired by a service facility before use. If the plug will not fit the outlet, have a proper outlet installed by a qualified electrician.

## Extension Cords

**Note:** Extension cords must not be used with this item's Charger.

## Symbology

	Double Insulated		Read the manual before set-up and/or use.
<b>V</b>	Volts		WARNING marking concerning Risk of Fire. Do not cover Charger ventilation ducts. Charge on actuateproof surface only.
~	Alternating Current		WARNING marking concerning Risk of Electric Shock. Properly connect Charger's power cord to appropriate outlet.
<b>A</b>	Amperes		WARNING marking concerning Risk of Explosion. Do not puncture, short, or open battery packs and do not charge damaged battery packs.
n <sub>0</sub> xxxx/min.	No Load Revolutions per Minute (RPM)		WARNING marking concerning Risk of Eye Injury. Wear ANSI-approved safety goggles with side shields.

## Specifications

Battery Pack	Bauer 20V Li-Ion, 3.0Ah / 63631, 1.5Ah / 63530 (sold separately)
Charger	Bauer 20V Li-Ion / 63529 (sold separately)
Nailer Input Rating	20VDC, 60/min
Actuation System	Single Sequential and Contact Actuation
Nail Type	18 Gauge 3/4" – 2" Brad

## Setup - Before Use:



Read the **ENTIRE IMPORTANT SAFETY INFORMATION** section at the beginning of this manual including all text under subheadings therein before set up or use of this product.

**Note:** For additional information regarding the parts listed in the following pages, refer to *Parts List and Diagram* on page 18.

## Functions

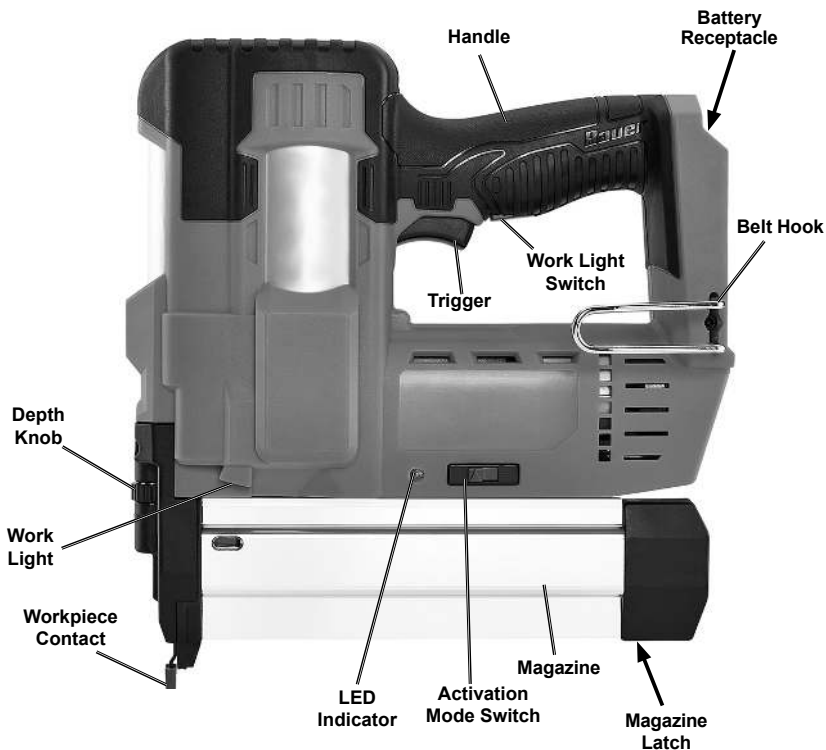

**Workpiece Contact** - The Workpiece Contact helps prevent the tool from driving unless it is pressed against an object.

## Operating Instructions



Read the **ENTIRE IMPORTANT SAFETY INFORMATION** section at the beginning of this manual including all text under subheadings therein before set up or use of this product.

## Tool Set Up

### **⚠️ WARNING**

**TO PREVENT SERIOUS INJURY FROM ACCIDENTAL DISCHARGE:**

**Make sure that the Trigger is in the off-position and remove its Battery**

**Pack before performing any procedure in this section.**

## Battery Charging

Charge battery after unpacking and before using this tool. Follow instructions included with battery charger (sold separately)

## Workpiece and Work Area Set Up

1. Designate a work area that is clean and well lit. The work area must not allow access by children or pets to prevent distraction and injury.
2. Secure loose workpieces using a vise or clamps (not included) to prevent movement while working.
3. There must not be objects, such as utility lines, nearby that will present a hazard while working.

## Single-Sequential Actuation Mechanism Definition

The single-sequential activation mechanism is designed to allow accurate placement of fasteners. Use the switch next to the LED Indicator to change modes. The tool should only actuate if the Workpiece Contact is pressed against the workpiece prior to pulling the Trigger. It should only actuate again if the Trigger is released and squeezed again. The Tool should not actuate if the Workpiece Contact is not pressed against an object.

## Single-Sequential Actuation Mechanism Testing Procedure

### **⚠️ WARNING**

**TO PREVENT SERIOUS INJURY FROM ACCIDENTAL DISCHARGE:**

**Empty the tool before this procedure. Point the tool at a piece of scrap wood when testing.**

1. Disconnect the Battery Pack from the tool.
2. Empty the magazine of fasteners.
3. Check that the Trigger and the Workpiece Contact move freely, without sticking.
4. Connect the Battery Pack to the tool making sure it clicks in place.
5. Set Activation Switch to the left (single-sequential actuation).
6. Test the tool by pressing the Workpiece Contact against the workpiece without pulling the Trigger. **The tool must not cycle (actuate).** If it cycles (actuates), stop immediately and have it repaired by a qualified service technician.
7. Hold the tool away, or off of the workpiece. The Workpiece Contact should return to its original position. Squeeze the Trigger. **The tool must not cycle (actuate).** If it cycles (actuates), stop immediately and take the tool to a qualified service technician.
8. Press the Workpiece Contact against the workpiece and squeeze the Trigger. **The tool must cycle (actuate) only once.** Release the Trigger, slide the nailer to a fresh piece of wood, and squeeze it again. **The tool must cycle (actuate) again only once.** With the Trigger depressed, carefully lift the tool and press it against the workpiece again. **The tool must not cycle (actuate).** If it fails to act in the manner explained in bold, have it repaired by a qualified service technician.

## Contact Actuation Mechanism Definition

The contact actuation mechanism allows rapid placement of fasteners. Use the switch next to the LED Indicator to change modes. The tool should only actuate if the Workpiece Contact is pressed against the workpiece and the Trigger is pulled. It should actuate again if the Trigger is released and pulled OR if the Workpiece Contact is lifted and pressed against the workpiece again. The tool should not actuate if the Workpiece Contact is not pressed against an object. **Contact Actuation should only be enabled and used by skilled operators who are aware of the hazards and use proper, safe work practices.**

## Contact Actuation Mechanism Testing Procedure

### **⚠WARNING**

**TO PREVENT SERIOUS INJURY FROM ACCIDENTAL DISCHARGE:**  
Point the tool at a piece of scrap wood when testing.

1. Disconnect the Battery Pack from the tool.
2. Load the magazine with fasteners.
3. Check that the Trigger and the Workpiece Contact move freely, without sticking.
4. Connect the Battery Pack to the tool making sure it clicks in place.
5. Set Activation Switch to the right (contact actuation).
6. Test the tool by pressing the Workpiece Contact against the workpiece without pulling the Trigger.  
**The tool must not cycle (actuate).**  
If it cycles (actuates), stop immediately and have it repaired by a qualified service technician.
7. Hold the tool away, or off of the workpiece. The Workpiece Contact should return to its original position. Squeeze the Trigger.  
**The tool must not cycle (actuate).**  
If it cycles (actuates), stop immediately and take the tool to a qualified service technician.
8. Press the Workpiece Contact against the workpiece and squeeze the Trigger.  
**The tool must cycle (actuate) only once.**  
Release the Trigger, slide the nailer to a fresh piece of wood, and squeeze it again.  
**The tool must cycle (actuate) again only once.**  
With the Trigger depressed, carefully lift the tool and press it against the workpiece again in a new location.  
**The tool must cycle (actuate) again only once.**  
If it fails to act in the manner explained in bold, have it repaired by a qualified service technician.

## Switchable Trigger

### **⚠WARNING**

**TO PREVENT SERIOUS INJURY FROM ACCIDENTAL DRIVING:**

- Release Trigger and point tool in a safe direction before changing actuation mode.
- ONLY** operate the tool with the Switch fully in one of the actuation mode positions.

1. Set the Activation Mode Switch to the right to enable Single Sequential operation for precise placement of fasteners.
2. Set the Activation Mode Switch to the left to enable Contact Actuation operation for rapid placement of fasteners.  
**Only a skilled operator who is aware of the hazards and uses proper, safe work practices should use Contact Actuation operation.**

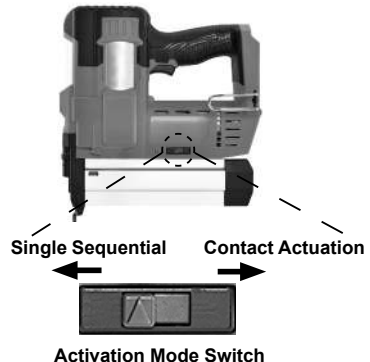

# Loading the Tool

## **⚠ WARNING**

### TO PREVENT SERIOUS INJURY FROM ACCIDENTAL DISCHARGE, BEFORE LOADING:



- **Wear ANSI-approved safety goggles with side shields.**  
Other people in the work area must also wear ANSI-approved impact safety goggles with side shields.
- **Release the Trigger.**
- **Disconnect the Battery Pack from the tool.**
- **Attempt to discharge the Tool into a piece of scrap wood to ensure that it is disconnected and is incapable of driving any fasteners.**

1. Depress the Latch and pull back the Sliding Magazine completely.

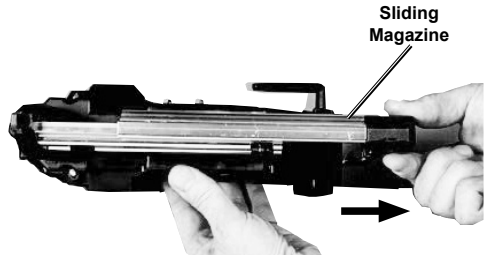
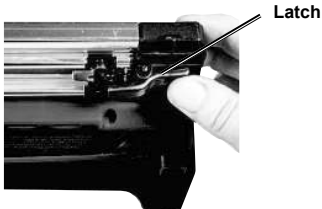

2. Load the pointed end of the nail strip into the bottom of the Fixed Magazine, laying the strip flat on the bed of Magazine.

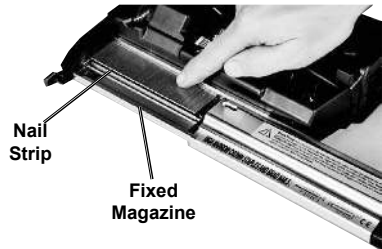

3. Make sure the heads of the nails fit in the slots in the Fixed Magazine, as shown.

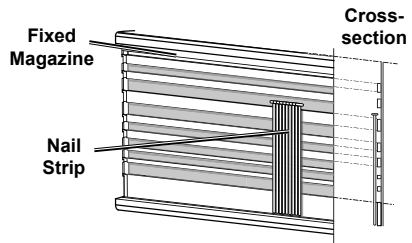

4. Slide strip forward into Drive Guide.

5. Gently push the Sliding Magazine inward and push forward until the Latch snaps and locks securely. **CAUTION!** Do not pinch your hand.

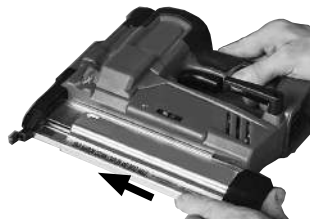

# General Operating Instructions

SAFETY

1. Make sure that the Trigger is in the off-position, then attach a fully charged Battery Pack making sure it clicks in place.
2. Before each use, test the tool as directed in the prior section.



**WARNING! TO PREVENT SERIOUS INJURY:** Keep second hand away from tool discharge area, especially if holding workpiece. Tool applies extreme force to fastener, and fasteners may deflect or discharge in an unexpected direction.

**WARNING! TO PREVENT INJURY:** Do not hold tool near body while driving. Tool recoil can cause injury.



**WARNING! TO PREVENT SERIOUS INJURY, INCLUDING PERMANENT HEARING LOSS:** Always wear hearing protection when using the tool.

SETUP

3. Position tool at desired fastener location, set the Activation Mode Switch, and depress the Workpiece Contact fully against the workpiece. Squeeze the Trigger to discharge a fastener.
4. **To change driving depth:** Disconnect Battery Pack and keep Workpiece Contact pointed away.

To reduce nail depth, turn the Depth Knob clockwise, toward .

To increase nail depth, turn the Depth Knob counterclockwise, toward .

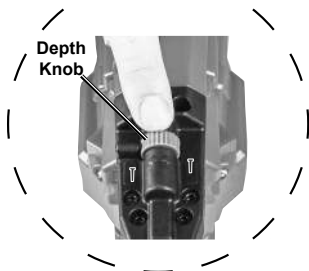

OPERATION

MAINTENANCE

5. **The LED Indicator:**



LED Indicator

- a. Flashing red indicates a jam in the Magazine. Stop and clear the jam.
  - b. Solid red indicates low battery. Remove Battery Pack and recharge it.
  - c. Flashing green indicates the tool is over heating. Stop using the tool immediately and allow it to cool down before continuing use.
  - d. Solid green indicates no fasteners are in the Magazine. Stop and reload tool.
  - e. If the LED is not illuminated this indicates the battery is fully charged and the fasteners are correctly installed.
6. **After use, to prevent accidents:**
    - a. **Release the Trigger.**
    - b. **Remove the Battery Pack.**
    - c. **Empty the Magazine.**
    - d. **Attempt to discharge the tool into a piece of scrap wood to ensure that it is disconnected and is incapable of driving any fasteners.**
    - e. **Release the Trigger again.**
    - f. **Clean external surfaces with clean, dry cloth.**
  7. **Store indoors out of children's reach.**

## Clearing a Jam

1. If the LED Indicator is flashing red, it indicates there is a jam in the Magazine. Stop and clear the jam before proceeding.
2. Remove the Battery Pack.
3. Open the Magazine by pressing the release Latch and sliding it open.

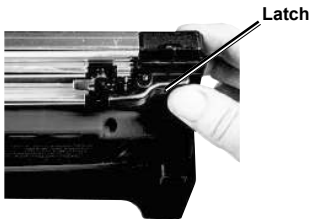

4. Remove the nail strip and jammed fastener.

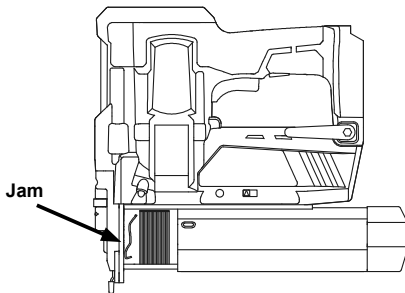

5. Reinstall the nail strip and Battery Pack. Close the Magazine. If the jam has been corrected, the LED Indicator will no longer be illuminated. If the LED is still flashing then the jam may be in the internal striking mechanism.
6. Remove the Battery Pack and nail strip.
7. Using the included 3mm Hex Key, remove the four screws located next to the Depth Knob.

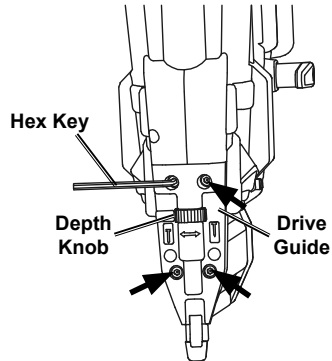

8. Remove the Drive Guide and jammed fastener.
9. Reattach the Drive Guide with the four screws. Use the Hex Key to tighten.
10. Make sure the Workpiece Contact moves smoothly without binding.
11. Reinstall the Battery Pack and nail strip. Check that the LED Indicator is not illuminated. If the LED is still flashing, have the tool serviced by a trained technician.

# **Bauer**

SAFETY

SETUP

OPERATION

MAINTENANCE

## Maintenance and Servicing



Procedures not specifically explained in this manual must be performed only by a qualified technician.

### **⚠ WARNING**

**TO PREVENT SERIOUS INJURY FROM ACCIDENTAL DISCHARGE:  
BEFORE ANY MAINTENANCE OR REPAIRS ARE DONE (including clearing jams):**



- **Wear ANSI-approved safety goggles with side shields.**  
Other people in the work area must also wear ANSI-approved impact safety goggles with side shields.
- **Release the Trigger.**
- **Detach the Battery Pack.**
- **Attempt to discharge the Tool into a piece of scrap wood to ensure that it is disconnected and is incapable of driving any fasteners.**
- **Empty the Magazine and leave it open during service.**  
The Magazine is spring-loaded and may cause parts or a fastener to fly out of the Tool.

**TO PREVENT SERIOUS INJURY FROM TOOL FAILURE:**

**Do not use damaged equipment. If abnormal noise or vibration occurs, have the problem corrected before further use.**

## Cleaning, Maintenance, and Lubrication

1. **BEFORE EACH USE**, inspect the general condition of the tool. Check for:
  - proper Workpiece Contact operation
  - free Workpiece Contact and Trigger movement
  - leaking, swollen, or cracked Battery Pack,
  - loose hardware,
  - misalignment or binding of moving parts,
  - cracked or broken parts, and
  - any other condition that may affect its safe operation.
2. **AFTER EACH USE**, perform the following procedures:
  - remove the Battery Pack and empty the Magazine
  - attempt to discharge the tool into a piece of scrap wood to ensure that it is disconnected and is incapable of driving any fasteners
  - clean the Drive Guide and Magazine to remove any accumulated dirt and debris. Lightly oil the Drive Guide
  - clean external surfaces with clean, dry cloth
  - store indoors out of children's reach.
3. **Li-Ion BATTERY MUST BE RECYCLED OR DISPOSED OF PROPERLY.**  
Do not short, incinerate or open battery.
4. **Disconnect Battery Pack and store Battery Pack, Charger, and tool in dry, indoor area out of reach of children and away from metal objects (i.e., paperclips, coins) to prevent shorting.**

# Troubleshooting

Problem	Possible Causes	Likely Solutions
Insufficient fastener depth.	<ol style="list-style-type: none"> <li>1. Incorrect tool depth setting.</li> <li>2. Incorrect lubrication or not enough lubrication.</li> </ol>	<ol style="list-style-type: none"> <li>1. Adjust depth setting, if available.</li> <li>2. Check for loose connections and make</li> </ol>
Fasteners drive too deeply.	<ol style="list-style-type: none"> <li>1. Incorrect Tool depth setting.</li> </ol>	<ol style="list-style-type: none"> <li>1. Adjust depth setting, if available.</li> </ol>
Tool cycles without driving fastener.	<ol style="list-style-type: none"> <li>1. Jammed fastener.</li> <li>2. Tool empty.</li> <li>3. Incorrect fasteners used.</li> <li>4. Magazine dirty or not lubricated properly.</li> </ol>	<ol style="list-style-type: none"> <li>1. Clear jammed fastener according to Clearing Jams instructions.</li> <li>2. Reload with correct fasteners.</li> <li>3. Empty, then reload with correct fasteners.</li> <li>4. Clean and lubricate Magazine and Pusher.</li> </ol>
Frequent jamming.	<ol style="list-style-type: none"> <li>1. Incorrect nail type.</li> </ol>	<ol style="list-style-type: none"> <li>1. Confirm nail collation type, diameter, angle, type, and length. Correct as needed.</li> </ol>
Tool will not start.	<ol style="list-style-type: none"> <li>1. Battery Pack not properly connected.</li> <li>2. Battery Pack not properly charged.</li> <li>3. Battery Pack burnt-out.</li> <li>4. Internal damage or wear. (Carbon brushes or Trigger, for example.)</li> </ol>	<ol style="list-style-type: none"> <li>1. Remove Battery Pack, make sure there are no obstructions, reinsert the Battery Pack according to its shape (it should only fit one way), and press firmly until the Battery Pack locks in place.</li> <li>2. Make sure Charger is connected and operating properly. Give enough time for Battery Pack to recharge properly.</li> <li>3. Dispose of old Battery Pack properly or recycle. Replace Battery Pack.</li> <li>4. Have technician service tool.</li> </ol>
Tool operates slowly.	<ol style="list-style-type: none"> <li>1. Forcing tool to work too fast.</li> <li>2. Battery Pack wearing out.</li> </ol>	<ol style="list-style-type: none"> <li>1. Allow tool to work at its own rate.</li> <li>2. Dispose of old Battery Pack properly or recycle. Replace Battery Pack.</li> </ol>
Performance decreases over time.	<ol style="list-style-type: none"> <li>1. Carbon brushes worn or damaged.</li> </ol>	<ol style="list-style-type: none"> <li>1. Have qualified technician replace brushes.</li> </ol>
Excessive noise or rattling.	<ol style="list-style-type: none"> <li>1. Internal damage or wear. (Carbon brushes or bearings, for example.)</li> </ol>	<ol style="list-style-type: none"> <li>1. Have technician service tool.</li> </ol>
Overheating.	<ol style="list-style-type: none"> <li>1. Forcing tool to work too fast.</li> <li>2. Blocked motor housing vents.</li> </ol>	<ol style="list-style-type: none"> <li>1. Allow tool to work at its own rate.</li> <li>2. Wear ANSI-approved safety goggles and NIOSH-approved dust mask/respirator while blowing dust out of motor using compressed air.</li> </ol>
 <p><b>Follow all safety precautions whenever diagnosing or servicing the tool. Disconnect Battery Pack and Charger power supply before service.</b></p>		

SAFETY

SETUP

OPERATION

MAINTENANCE

## PLEASE READ THE FOLLOWING CAREFULLY

---

THE MANUFACTURER AND/OR DISTRIBUTOR HAS PROVIDED THE PARTS LIST AND ASSEMBLY DIAGRAM IN THIS MANUAL AS A REFERENCE TOOL ONLY. NEITHER THE MANUFACTURER OR DISTRIBUTOR MAKES ANY REPRESENTATION OR WARRANTY OF ANY KIND TO THE BUYER THAT HE OR SHE IS QUALIFIED TO MAKE ANY REPAIRS TO THE PRODUCT, OR THAT HE OR SHE IS QUALIFIED TO REPLACE ANY PARTS OF THE PRODUCT. IN FACT, THE MANUFACTURER AND/OR DISTRIBUTOR EXPRESSLY STATES THAT ALL REPAIRS AND PARTS REPLACEMENTS SHOULD BE UNDERTAKEN BY CERTIFIED AND LICENSED TECHNICIANS, AND NOT BY THE BUYER. THE BUYER ASSUMES ALL RISK AND LIABILITY ARISING OUT OF HIS OR HER REPAIRS TO THE ORIGINAL PRODUCT OR REPLACEMENT PARTS THERETO, OR ARISING OUT OF HIS OR HER INSTALLATION OF REPLACEMENT PARTS THERETO.

SAFETY

SETUP

OPERATION

MAINTENANCE

Record Product's Serial Number Here: \_\_\_\_\_

**Note:** If product has no serial number, record month and year of purchase instead.

**Note:** Some parts are listed and shown for illustration purposes only, and are not available individually as replacement parts. Specify UPC 193175499943 when ordering parts.

# Parts List and Diagram

## Parts List

Part	Description	Qty	Part	Description	Qty	Part	Description	Qty
1	Screw, M4 X 6	1	44	Big Cylinder Cover Seal	1	90	Safety Shaft Front Spring	1
2	Small Swing Link	1	45	Big Cylinder Cover	1	91	Depth Knob	1
3	Rotating Shaft 1	1	46	Big Piston Y Seal	1	92	Depth Knob Screw	1
4	Torsional Spring 1	1	47	Big Piston	1	93	LED Board	1
5	Gasket 1	1	48	Hollow Shaft	1	94	LED Cover	2
6	Quill Bearing	1	49	Screw, M4 x 6	1	95	LED B	1
7	Middleware	1	50	Connecting Bar	1	96	LED B Cover	1
8	Middleware Cover	1	51	Rotating Shaft Pin	1	97	Activation Mode Switch	1
9	Screw, M4 x 6	1	52	Rotating Shaft Magnet	1	98	LED C	1
10	Screw, M4 x 6	1	53	Rotating Shaft	1	99	LED C Holder	1
11	Self-Locking Nut	1	54	Power Switch	1	100	Stick	1
12	Copper Gasket 1	1	55	Trigger Spring	1	101	Screw cover	2
13	Swinging Rod Pin	2	56	Trigger	1	102	Screw, M4 x 10	2
14	Connector	1	57	Work Light Switch	1	103	Screw, M4 x 6	2
15	Ling Swing Link	1	58	Small Trigger Spring	1	104	Screw, M4 x 8	2
16	Short Swing Link	1	59	Work Light Cover	1	105	Screw, M4 x4	1
17	Rotating Shaft 2	1	60	Screw, M4 x 25	2	106	Spring	1
18	Copper Gasket 2	1	61	Screw, M4 x 20	4	107	Steel Ball	1
19	Torsional Spring 2	1	62	Aluminum Bracket	1	108	Workpiece Contact	1
20	Copper Gasket 3	1	63	Bracket Bearing	2	109	Safety Bracket	1
21	Stopper	1	64	Gears Connecting Bar	1	110	Safety Bracket Spring	1
22	Screw, M4 x 6	1	65	Gear A	4	111	Safety Bracket Guard	2
23	Gasket 2	1	66	Gear Tray A	1	112	Depth Knob Cover	1
24	Screw, M4 x 45	1	67	Gear B	7	113	Screw, ST3 x 4	2
25	Small Cylinder Seal	1	68	Gear Tray B	1	114	Contact Cover	1
26	Small Cylinder	1	69	Inner Gear A	1	115	Screw, M5 x 14	2
27	Small Cylinder Irregular Seal	1	70	Inner Gear B	1	116	Screw, M4 x 16	2
28	Small Piston Rectangular Seal	1	71	Round Spacer	2	117	Drive Guide	1
29	Small Piston Seal	1	72	Screw, M4 x 8	1	118	Fixed Magazine	1
30	Small Piston Inner Seal	1	73	Motor Cover	2	119	Ling Iron Rod	1
31	Small Piston	1	74	Pin, 2.5 x 44	1	120	Fixed Clip Iron	1
32	Magnet Plug	1	75	Small Gear	1	121	Screw, M4 x 8	3
33	Small Piston Magnet	1	76	Motor	1	122	Magazine Latch	1
34	Driving Pin Connecting Block	1	77	Upper Housing Body	1	123	Clip Trigger Pin	1
35	Pin, 3 x 9.5	1	78	Lower Housing Body	1	124	Fixed Clip Rubber	1
36	Driving Pin	1	79	Screw, ST4 x 15	10	125	Clip Trigger Spring	1
37	Hall A Cover	1	80	Belt Hook	1	126	Screw, M4 x 6	1
38	Hall A	1	81	Bolt	1	127	Magazine Cover	1
39	Bumper Block	1	82	Self-Locking Nut	1	128	Nail Feeder	1
40	Screw, M4 x 16	1	83	Battery PCB	1	129	Magazine Magnet	1
41	Iron Cover on Cylinder	1	84	Electrode Holder	1	130	Send Nail Limiter	2
42	Cylinder Cover Seal	1	85	Battery Pack (sold separately)	0	131	Clip Spring	2
43	Cylinder Cover	1	86	Safety Switch	1	132	Sliding Magazine	1
			87	Safety Shaft Gasket	2	133	Clip Trigger Bracket	1
			88	Safety Shaft Rear Spring	1	134	Screw, M4 x 30	1
			89	Safety Shaft	1	135	Hex Key, 3mm (not shown)	1

SAFETY

SETUP

OPERATION

MAINTENANCE

# Assembly Diagram

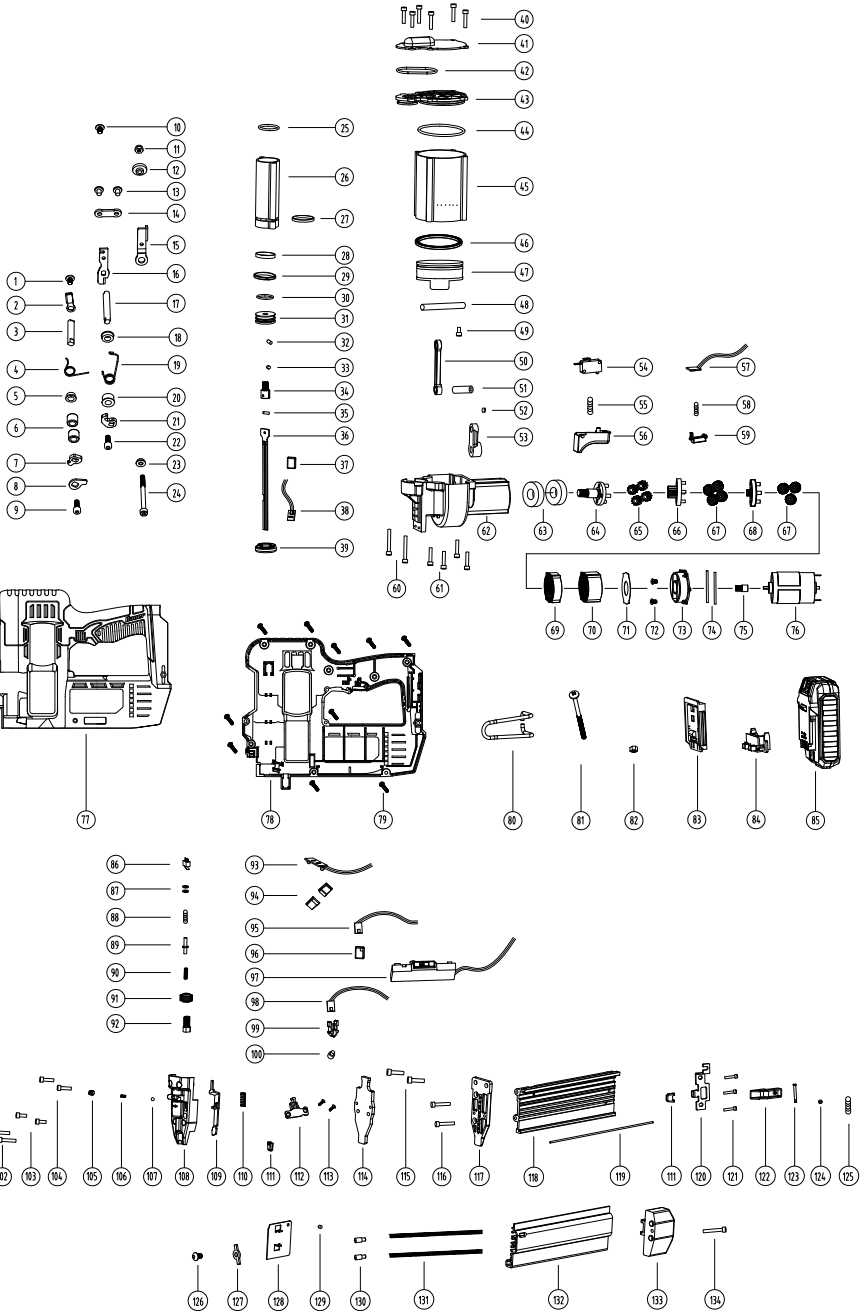

SAFETY

SETUP

OPERATION

MAINTENANCE

## Limited 90 Day Warranty

Harbor Freight Tools Co. makes every effort to assure that its products meet high quality and durability standards, and warrants to the original purchaser that this product is free from defects in materials and workmanship for the period of 90 days from the date of purchase. This warranty does not apply to damage due directly or indirectly, to misuse, abuse, negligence or accidents, repairs or alterations outside our facilities, criminal activity, improper installation, normal wear and tear, or to lack of maintenance. We shall in no event be liable for death, injuries to persons or property, or for incidental, contingent, special or consequential damages arising from the use of our product. Some states do not allow the exclusion or limitation of incidental or consequential damages, so the above limitation of exclusion may not apply to you. THIS WARRANTY IS EXPRESSLY IN LIEU OF ALL OTHER WARRANTIES, EXPRESS OR IMPLIED, INCLUDING THE WARRANTIES OF MERCHANTABILITY AND FITNESS.

To take advantage of this warranty, the product or part must be returned to us with transportation charges prepaid. Proof of purchase date and an explanation of the complaint must accompany the merchandise. If our inspection verifies the defect, we will either repair or replace the product at our election or we may elect to refund the purchase price if we cannot readily and quickly provide you with a replacement. We will return repaired products at our expense, but if we determine there is no defect, or that the defect resulted from causes not within the scope of our warranty, then you must bear the cost of returning the product.

This warranty gives you specific legal rights and you may also have other rights which vary from state to state.

The logo for Bauer, featuring the word "Bauer" in a bold, italicized, sans-serif font with a trademark symbol (TM) at the end.

26677 Agoura Road • Calabasas, CA 91302 • 1-888-866-5797