



DSW 1005-E



en	English	1
----	---------------	---

1 Information about the documentation

1.1 Explanation of signs used







1.1.1 Warnings

Warnings alert persons to hazards that occur when handling or using the product. The following signal words are used in combination with a symbol:

	DANGER! Draws attention to imminent danger that will lead to serious personal injury or fatality.
	WARNING! Draws attention to a potential hazard that could lead to serious personal injury or fatality.
	CAUTION! Draws attention to a potentially dangerous situation that could lead to slight personal injury or damage to the equipment or other property.

1.1.2 Symbols

The following symbols are used in this document:

	Read the operating instructions before use.
	General warning
	Warning: hazardous electrical voltage
	Warning: risk of cutting injury
	Dealing with recyclable materials
	Do not dispose of electric tools, machines or appliances together with household waste.





1.1.3 Symbols on the product

The following symbols are used on the type identification plate:

/min	Revolutions per minute
n_0	Rated speed under no load
\varnothing	Diameter

1.1.4 Mandatory signs

The following obligation signs are used on the product:

	Wear eye protection
	Wear a hard hat and ear protection
	Wear protective gloves
	Wear safety shoes



Lifting points

1.1.5 Illustrations

The illustrations in these operating instructions are intended to promote a better understanding and may deviate from the actual version of the product.

2	These numbers refer to the corresponding illustrations found at the beginning of these operating instructions.
3	The numbering reflects the order of the work steps in the illustration and may deviate from the numbering of work steps in the text.
11	Item reference numbers are used in the overview illustration and refer to the numbers used in the product overview section.
	These characters are intended to specifically draw your attention to certain points when handling the product.

1.2 Declaration of conformity

We declare, on our sole responsibility, that the product described here complies with the applicable directives and standards. A copy of the declaration of conformity can be found at the end of this documentation.

The technical documentation is filed and stored here:

Hilti Entwicklungsgesellschaft mbH | Tool Certification | Hiltistraße 6 | 86916 Kaufering, DE

2 Safety

2.1 Safety instructions

The safety instructions in the section below contain all general safety instructions for power tools that the applicable standards require to be stated in the operating instructions. Consequently, some of the instructions might not be relevant for this tool.

2.1.1 Proper arrangement of the workplace

- ▶ Approval must be obtained from the site engineer or site management before beginning drilling and sawing work. Drilling and sawing work on buildings and other structures may influence the statics of the structure, especially when steel reinforcing bars and load-bearing components are cut through.
- ▶ Ensure that good lighting is in use.
- ▶ Ensure that the workplace is well ventilated. Exposure to dust at a poorly ventilated workplace may result in damage to the health.
- ▶ Keep the workplace tidy. Objects which could cause injury should be removed from the working area. Untidiness at the workplace can lead to accidents.
- ▶ In order to avoid injuries and to prevent the diamond wire becoming trapped and stuck, steel wedges and/or supports must be used to prevent uncontrolled movement of objects that are being cut free.
- ▶ Ensure that adequately-sized supports are correctly installed so that the remaining structure maintains its stability after completion of the cutting work and removal of the part cut away.
- ▶ Never loiter in areas where loads are suspended by crane or lifting equipment.
- ▶ The area of the cut or the opening created by the cutting process must be safely and visibly cordoned off in order to avoid the risk of persons falling.

- ▶ Wear personal protective equipment. Wear safety footwear, protective gloves, a hard hat and protective glasses.
- ▶ Wear respiratory protection if the work causes dust.
- ▶ Dress properly for the work. Do not wear loose clothing or jewelry as it can be caught in moving parts. Contain long hair.
- ▶ Keep children away. Keep other persons away from the working area.
- ▶ Do not allow other persons to touch the equipment or the extension cable.
- ▶ Avoid working in awkward body positions. Make sure you work from a safe stance and stay in balance at all times.
- ▶ To avoid presenting a tripping hazard, always ensure that cables and hoses leading to the machine are laid flat on the floor.
- ▶ Keep cables and hoses away from rotating parts.
- ▶ In cooperation with the site engineer or architect, check to ensure that no gas, water, electricity or other supply lines are located in the cutting area. Supply lines located close to the cutting area which, for instance, could be damaged by falling parts, must be specially protected and temporarily taken out of operation and switched off where necessary.
- ▶ Ensure that the cooling water used is drained or extracted in a suitably controlled manner. Cooling water that is allowed to flow away or spray around in an uncontrolled manner can lead to damage and accidents. The fact that water can drain away into internal, hidden cavities must also be taken into account.
- ▶ Don't work from a ladder.

2.1.2 General safety rules

- ▶ Use the machine only after you have read the operating instructions, after becoming familiar with the content of the instructions and after receiving training by a **Hilti** specialist. Observe all warnings and instructions.
- ▶ Use the right tool or equipment for the job. Do not use the machine for purposes for which it was not intended. Use it only as directed and when in faultless condition.
- ▶ Use the machine and its accessories etc. in accordance with these instructions and in the manner intended for the particular type of machine. Take the working conditions and the work to be performed into account. Use of this machine in situations other than those intended could result in hazardous situations.
- ▶ Take influences of the surrounding area into account. Do not use the machine where there is a risk of fire and explosion. Electric tools and machines generate sparks which may ignite dust or gas.
- ▶ Keep the grips clean, dry and free from oil and grease.
- ▶ Do not overload the machine. It will work more efficiently and more safely within its intended performance range.
- ▶ Never leave the machine unattended.
- ▶ Store machines in a secure place when not in use. When not in use, machines must be stored in a dry, high place or locked away out of reach of children.
- ▶ Always disconnect the supply cord from the electric supply when the machine is not in use (e.g. during breaks between working), before making adjustments, before cleaning and maintenance and before changing the sawing wire. This safety precaution prevents the machine being switched on unintentionally.
- ▶ Remove adjusting keys or wrenches before switching the machine on. A tool or a key left attached to a rotating part of the machine may result in personal injury.
- ▶ Before use, the machine, the sawing wire and accessories must be checked carefully to ensure that all items function faultlessly and as intended. Check that moving parts function faultlessly, without sticking, and that no parts are damaged. In order to ensure

faultless operation of the machine, all parts must be fitted correctly and must meet the necessary requirements. Damaged parts must be repaired or replaced properly by an authorized service center.

- ▶ Avoid skin contact with drilling and sawing slurry.
- ▶ Wear a protective mask during work that generates dust, e.g. dry cutting. Connect a dust removal system. Working on materials hazardous to the health (e.g. asbestos) is not permissible.
- ▶ Follow the instructions concerning care and maintenance.
- ▶ Children are not permitted to play with the machine and must be instructed accordingly.
- ▶ The machine is not intended for use by children, by debilitated persons or those who have received no instruction or training.

2.1.3 Electrical safety

- ▶ Take steps to avoid electric shock. Avoid body contact with earthed or grounded surfaces such as pipes, radiators, ranges or refrigerators.
- ▶ Check the machine's power cables at regular intervals and have them replaced by a qualified specialist if found to be damaged. Check the extension cables at regular intervals and replace them if found to be damaged.
- ▶ Check the condition of the machine and its accessories. Do not operate the machine and its accessories if damage is found, if the machine is incomplete or if its controls cannot be operated faultlessly.
- ▶ If an electric cable is damaged while working, do not touch the cable – switch off at the main switch and unplug the supply cord.
- ▶ Damaged or faulty switches must be replaced at a **Hilti** service center. Do not use a machine, power tool or appliance that cannot be switched on and off at the main switch.
- ▶ Have the machine, power tool or appliance repaired only by a trained electrical specialist (**Hilti** Service) using genuine Hilti spare parts. Failure to observe this point may result in risk of accident to the user.
- ▶ Do not use the supply cords for purposes for which they are not intended. Never carry the machine by the supply cord. Never pull the plug out of the power outlet by pulling the supply cord.
- ▶ Do not expose the supply cords to heat, oil or sharp edges.
- ▶ Connect the machine and its ancillary equipment only to a power source equipped with an earth/ground conductor and ground fault circuit interrupter (PRCD). Check that these items are in perfect working order before operating the equipment. If a generator is used, connect it to a grounding/earthing rod driven into the ground.
- ▶ Make sure that the mains voltage corresponds to the specification given on the type plate.
- ▶ Electric cables and their plug connectors must be kept dry. When not in use, close power outlets with the cover provided.
- ▶ Use only extension cables of a type approved for the application and with conductors of adequate gauge. Do not use rolled-up extension cables. A rolled-up cable may cause a drop in power and may result in the cable overheating.
- ▶ Disconnect the electric supply before beginning cleaning and maintenance work or in the event of an interruption between periods of operation.
- ▶ Please note that certain components of the power converter may retain an extremely dangerous (potentially fatal) high voltage for up to 10 minutes after disconnection from the electric supply.
- ▶ Before beginning work, check the working area (e.g. using a metal detector) to ensure that no concealed electric cables or gas and water pipes are present. External metal

parts of the machine may become live, for example, when an electrical cable is damaged accidentally. This presents a serious risk of electric shock.

2.1.4 Requirements to be met by users

- ▶ The wire saw may be operated only by specialists who have received training in concrete cutting techniques. These persons must be completely familiar with the content of these operating instructions and must have been trained by a **Hilti** specialist on the safe application of these instructions.
- ▶ Stay alert, watch what you are doing and use common sense when working. Do not use the machine while you are tired or under the influence of drugs, alcohol or medication. A moment of inattention may result in serious personal injury.
- ▶ The user and any other persons in the vicinity must wear suitable eye protection, a hard hat, ear protection, protective gloves and safety footwear while the machine is in use.
- ▶ Dust from material such as paint containing lead, some wood species, minerals and metal may be harmful. Contact with or inhalation of the dust may cause allergic reactions and/or respiratory diseases among operators or bystanders. Certain kinds of dust such as oak and beech wood dust are classified as carcinogenic, especially in conjunction with additives for wood conditioning (chromate, wood preservative). Material containing asbestos may be worked on only by specialists. Where the use of a dust-extraction device is possible it shall be used. To achieve a high level of dust collection, use a suitable vacuum cleaner of the type recommended by **Hilti** for wood dust and/or mineral dust together with this machine. Ensure that the workplace is well ventilated. Use of a dust mask of the filter class P2 is recommended. Follow national requirements for the materials you want to work with.

2.1.5 Safety during operation

- ▶ Before use, check that the wire saw and its components, the wire and its connectors as well as the accessories are in good condition and in perfect working order. Make sure that any damage or malfunctions are rectified in a professional manner before operation commences.
- ▶ Position the control unit as far as possible outside the danger zone and remain in the vicinity of the control panel during cutting operations.
- ▶ Work with the saw may begin only when the wire saw and the pulley stands have been securely and rigidly fastened to a solid supporting surface. A falling object could result in serious personal injury or damage to property or equipment.
- ▶ Connect the electric power and compressed air supply only once the wire saw has been set up completely.
- ▶ Operate the saw only when the wire guards / cover are correctly fitted and when the sawing wire has been fed through the hollow axles of the pulley stands mounted right at the wire entry and exit points.
- ▶ Persons may enter the danger area (e.g. to adjust the pulleys or water nozzles, hammer in wedges, etc.) only after the emergency stop button has been pressed and the drive wheel has come to a standstill.
- ▶ Adhere to the permissible drive unit parameters and recommended guide values for wire speed and advance speed while sawing.
- ▶ Use only sawing wires that comply with the requirements of EN 13236.
- ▶ The number of wire breakages experienced can be reduced considerably by using high-quality wires and wire connectors and the appropriate crimping tools for fitting connectors.
- ▶ The sawing wire may get hot. Don't touch it unless you are wearing protective gloves.

- ▶ Use only fastening materials of adequate size (anchors, bolts, etc.) to fasten the pulley stands for the wire saw and to secure the object being cut.
- ▶ If equipment such as scaffolding, platforms or ladders is used, check that this equipment complies with regulations, that it is undamaged and set up in accordance with regulations.
- ▶ At all times while the saw is in operation, the operator must ensure that no persons are present in the danger area. This also applies to the area not immediately visible to the operator, i.e. the area behind or below the object in which the cut is being made. If necessary, a large area must be cordoned off or security personnel posted.
- ▶ Stay alert at all times. Monitor the progress of the sawing operation and keep an eye on the cooling water system and the area surrounding the workplace. Do not operate the machine if your full attention is not on the job.
- ▶ No modifications may be made to the saw system. Modification of the factory-set frequency converter parameters is strictly prohibited.

2.1.6 Additional safety instructions for wire saws

Safety measures at the danger area



Note

The danger area extends to at least twice the radius of the length of wire that would be unleashed in the event of the wire breaking and also includes the area in the extended axis of the directions in which the wire is running.

The scope of this danger area is not limited unless suitable protective devices are installed (protective barriers or curtains, wire guards, etc.). The protective devices must be designed and installed in such a way that they prevent wire whiplash and safely and reliably stop any flying fragments or debris.

- ▶ The operator is responsible for ensuring that the correct safety measures are taken at the workplace. It may be necessary to cordon off a large area and position security personnel accordingly.
- ▶ Make sure that adequate safety precautions are taken at the sawing area so that neither the operator nor other persons can be injured and no damage can be caused to equipment or other property in the event of wire breakage or due to flying fragments or debris. Safety measures must also be implemented in the area behind the object in which the cut is being made.
 - ◁ Persons may **NEVER** enter the danger area while the wire drive unit is switched on.
- ▶ Use only fastening materials of adequate dimensions to fasten the pulley stands for the wire saw and to secure the object being cut.
 - ◁ Work with the saw may begin only when the wire saw and the pulley stands have been securely and rigidly fastened to a solid supporting surface. A falling object could result in serious personal injury or damage to property or equipment.
- ▶ Check that the wire saw and its components function correctly before use.
- ▶ Connect the electric power and compressed air supply only once the wire saw has been set up completely.
- ▶ Position the control unit as far as possible outside the danger zone and make sure that you remain close to the control panel during cutting operations.
- ▶ When setting up and operating the saw system and when removing parts that have been cut away, always ensure that no persons are below the area in which you are working. Falling objects could cause serious injury.
- ▶ Keep any free (unsupported) lengths of sawing wire as short as possible (max. 3.5 m).

- ▶ Mount pulley stands at the wire entry and exit points in order to reduce the risk of wire whiplash.
 - ◁ The whiplash effect results in rapid acceleration of the sawing wire, possibly causing parts of the wire to fly off with great force.
- ▶ Make sure there are no objects (e.g. scaffold bars) within the areas in which whiplash may occur.
 - ◁ In the event of wire breakage, the free end of the sawing wire could be deflected in an unforeseen direction by an object of this kind.
- ▶ Operate the saw only when the wire guards / covers are correctly fitted and when the sawing wire has been fed through the hollow axles of the pulley stands mounted right at the wire entry and exit points.
- ▶ Always wear protective gloves.
 - ◁ The wire gets hot and may cause injury such as cuts or burns.

2.1.7 Safety instructions applicable to transporting the wire saw

- ▶ Avoid lifting and carrying heavy objects. Use suitable lifting equipment and means of transport and share heavy loads between several people.
- ▶ Use the grips provided for transportation. Keep the grips clean and free from oil and grease.
- ▶ Bear in mind that the machine could fall over. Stand the machine only on a solid, level surface. Use the forward-facing pivoting pulleys to help steady the wire saw against a suitable surface.
- ▶ Secure the machine and its components to prevent movement or falling over during transportation.
- ▶ The machine may be lifted by crane only using tested and approved lifting gear at the lifting points provided. Before lifting, check that all removable items of equipment are securely attached to the drive unit and that the end stop is fitted. Never loiter beneath a load suspended by a crane or lifting equipment.

3 Description

3.1 Symbols on the control unit

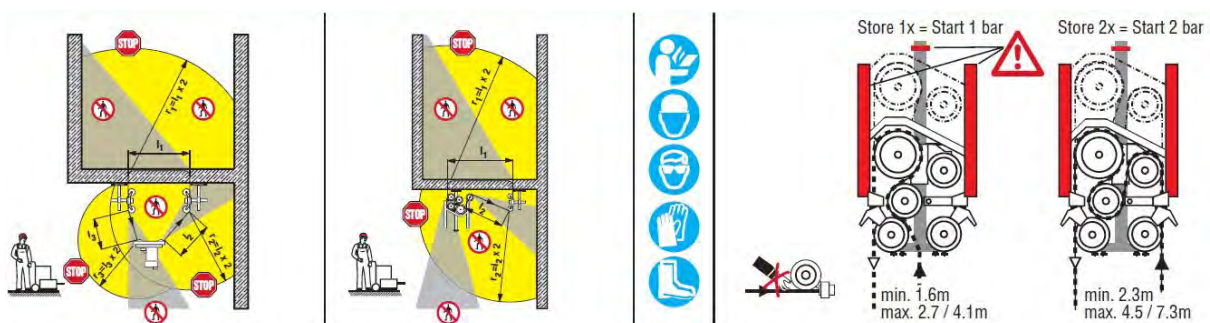

While the equipment is in operation, nobody may enter or remain within the danger zones shown.

3.2 Safety distance

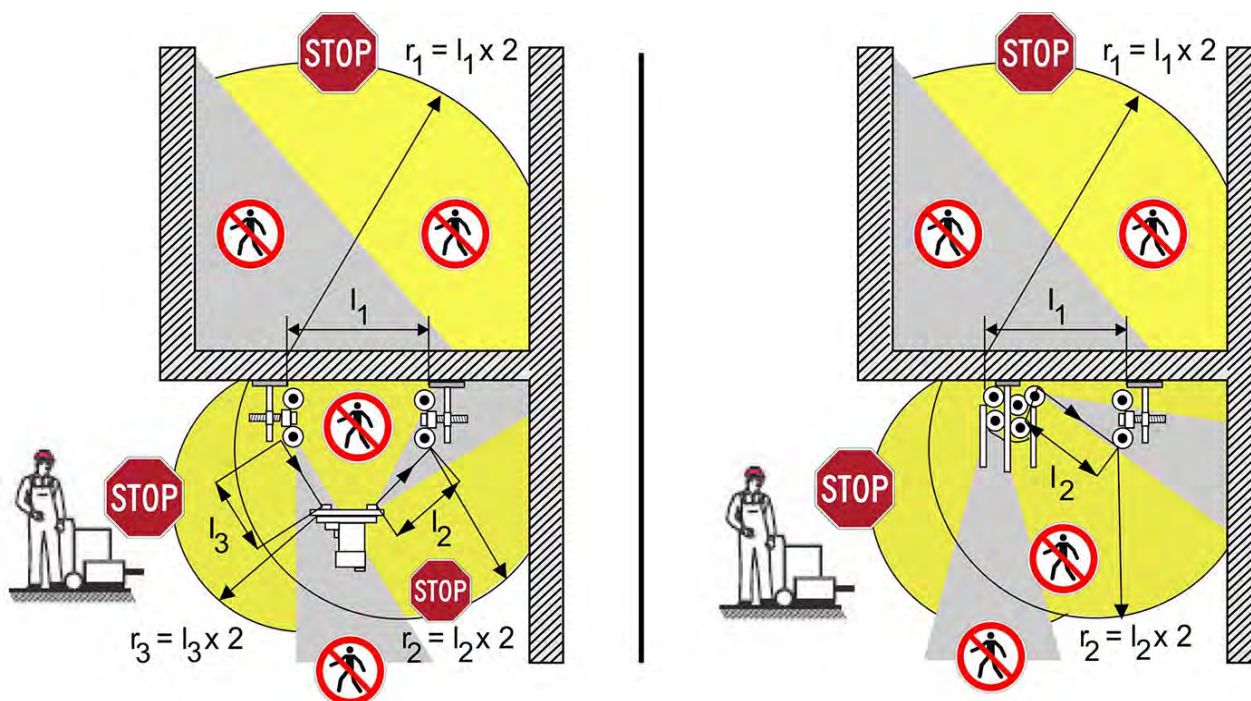

Always maintain the safety distance.

It is absolutely essential that the safety instructions regarding the safety distance are observed.

3.3 Designations of controls

3.3.1 Layout of components

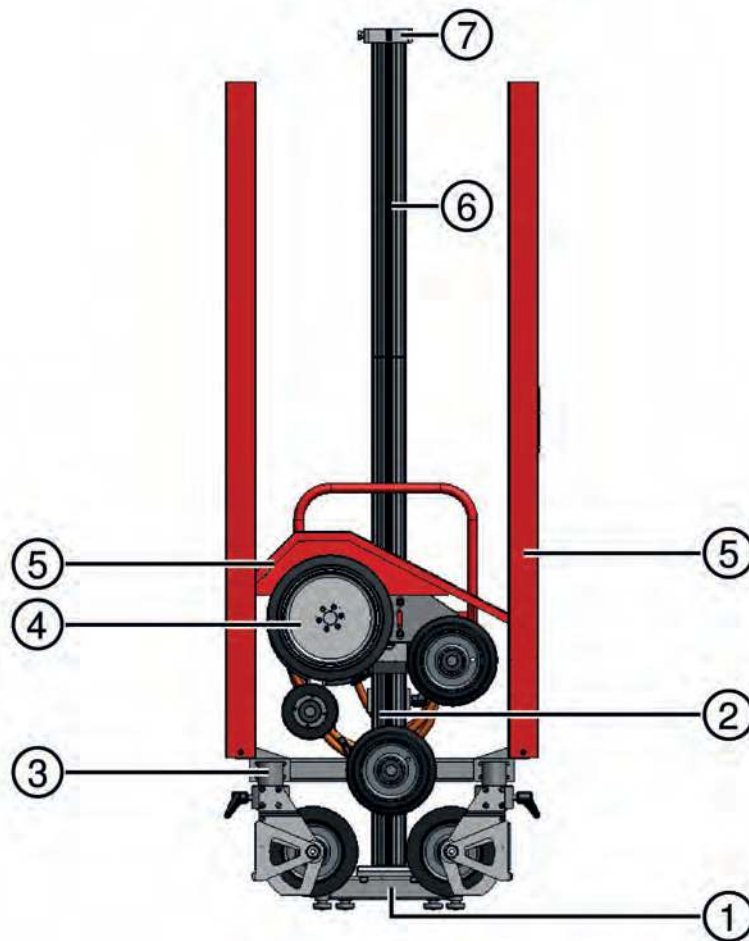

- | | |
|-----------------------------|-------------------------------------|
| ① Base plate | ⑤ Guards |
| ② Guidance and advance unit | ⑥ Wire storage extension (optional) |
| ③ Pivoting pulley bearer | ⑦ End stop |
| ④ Drive wheel | |

3.3.2 Positioning template



- | | |
|---------------|----------------------------------|
| ① Grip | ③ Wire feedthrough hole |
| ② Edge of cut | ④ Pivoting hole-center indicator |

⑤ Optimum anchor position

⑥ Holding magnets for fastening to the base plate

3.3.3 Base plate

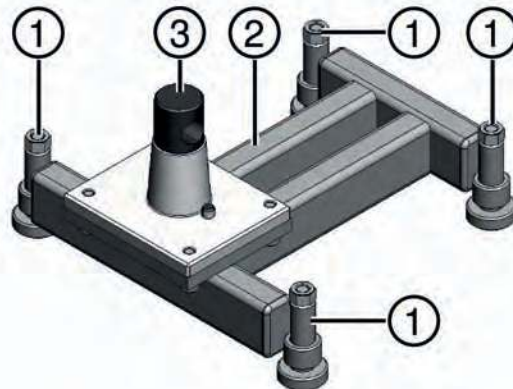

① Leveling screws

③ Connecting taper

② Anchor slot

3.3.4 Wire guidance and advance unit

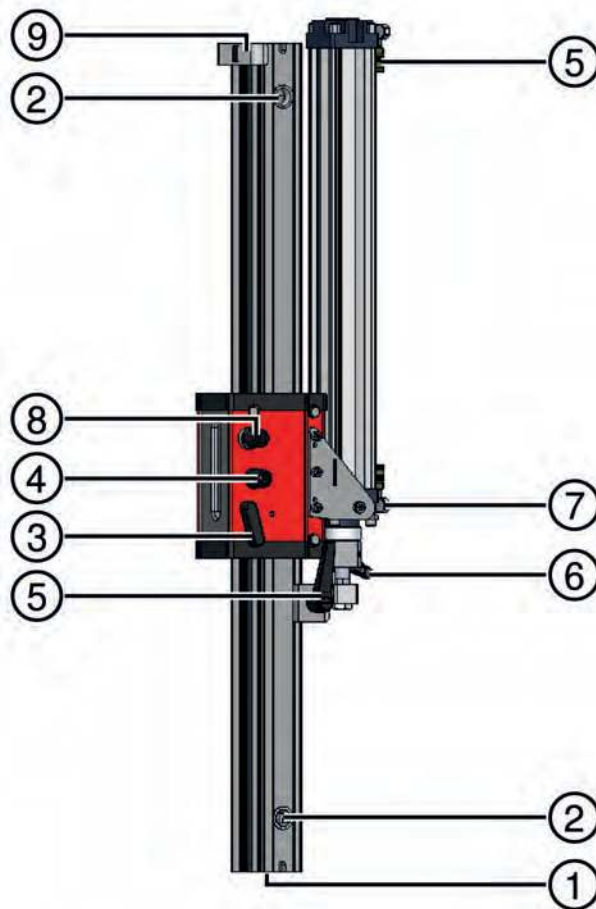

① Internally tapered connectors

④ Manual advance drive unit

② Eccentric pins

⑤ Piston rod lock

③ Carriage lock

⑥ Return stop

- ⑦ Compressed air connection
- ⑧ Drive interface and locking mechanism
- ⑨ End stop

3.3.5 Pivoting pulley bearer

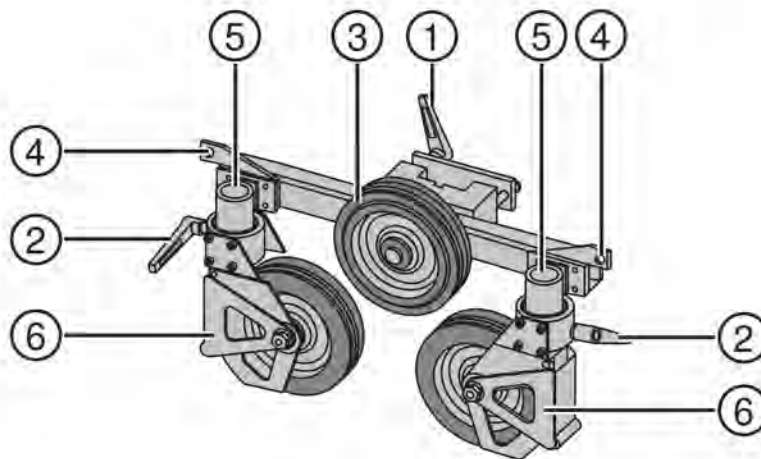

- ① Mounting interface and clamping lever
- ② Pivoting pulley locking lever
- ③ Wire storage pulley
- ④ Guard mounting hole
- ⑤ Hollow axles
- ⑥ Guard

3.3.6 Electric drive unit

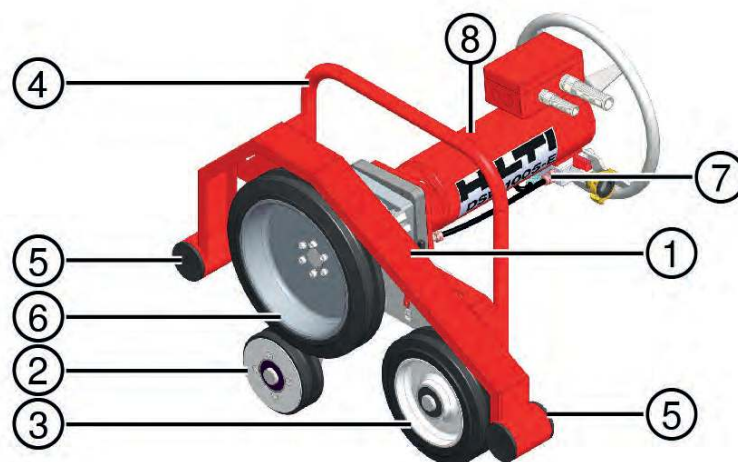

- ① Fastening interface
- ② Drive wheel
- ③ Wire storage pulley
- ④ Carrying handle and grip
- ⑤ Guides for side guard
- ⑥ Traction pulley
- ⑦ Cooling water connections, inlet / outlet
- ⑧ Motor

3.3.7 Guard

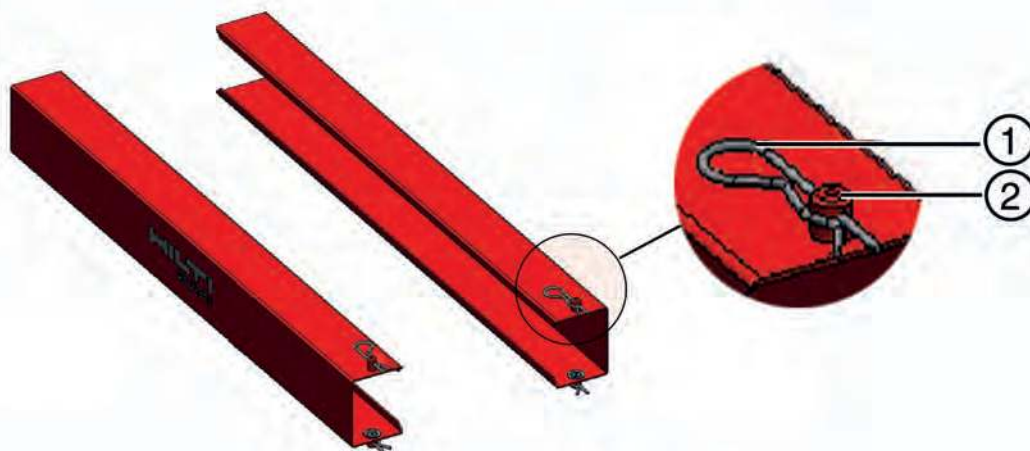

① Cotter pin

② Stud for holding wire storage unit

3.3.8 Control unit connections and attached parts

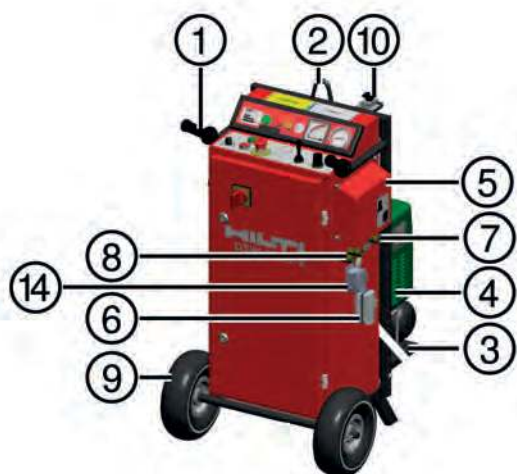

- ① Transport handles
- ② Lifting point
- ③ Air compressor mounting shelf
- ④ Air compressor
- ⑤ Control unit cooling air exit
- ⑥ Power cable socket
- ⑦ Compressed air connection, compressor

- ⑧ Compressed air connection, wire advance unit
- ⑨ Transport wheels
- ⑩ Vice for fitting wire connectors
- ⑪ 400 V / 32 A supply socket
- ⑫ 230 V power outlets
- ⑬ Control unit door lock
- ⑭ Control cable

3.3.9 Control unit operating controls

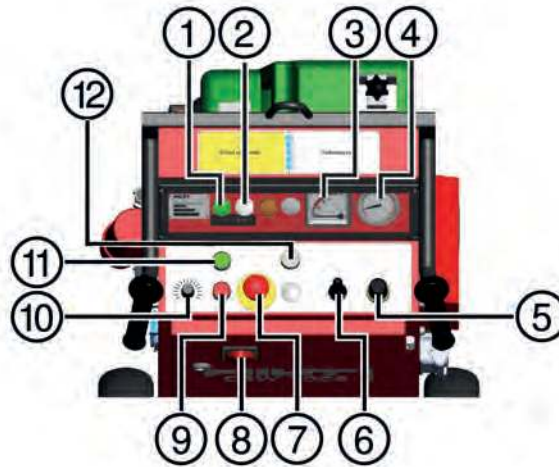

- | | |
|--|--|
| ① “Ready for operation” indicator (lights green) | ⑥ Advance direction selector lever (up/neutral/down) |
| ② Fault indicator (lights red) | ⑦ Emergency off button |
| ③ Gauge showing current input in amps | ⑧ Main switch |
| ④ Gauge showing advance pressure in bar | ⑨ Drive “Off” (red) |
| ⑤ Advance pressure regulator (lift knob to unlock) | ⑩ Wire speed adjustment in m/s |
| | ⑪ Drive “On” (green) |
| | ⑫ Clear button |

3.4 Intended use

This equipment complies with IEC 61000-3-12 provided that the short-circuit power S_{SC} at the interface point between the user’s supply and the public supply network is greater than or equal to 350. It is the responsibility of the installer or user of the equipment to ensure, by consultation with the public supply network operator, that the equipment is connected only to a supply with a short-circuit power S_{SC} of greater than or equal to 350. The wire saw is designed for the technical demolition of steel, concrete, stone or brickwork structures in construction and civil engineering applications. Use extending beyond this is considered to be not as directed and requires to be clarified in advance with the manufacturer.

The operator in charge must be aware of the possible dangers and of his responsibility for safety, both with regard to himself and to others. The operator is responsible for securing the danger area by cordoning it off and taking protective measures (guards, etc.) as necessary.

The wire saw is designed for a maximum cutting length of 2 m. The maximum distance between the pivoting pulleys at the machine and the wire entry or exits points must not exceed 3.5 m.

The wire saw may be operated only by specialists who have received training in concrete cutting techniques. These persons must be completely familiar with the content of these operating instructions and must have been trained by a Hilti specialist on the safe application of these instructions.

National regulations and laws, as well as the operating instructions and the safety information applicable to the accessories used (e.g. sawing wire, fastening accessories, lifting equipment, compressor, etc.) must be observed.

Do not use the saw to cut loose objects or objects held by hand against the sawing wire.

Use of the wire saw for purposes other than wire sawing is strictly prohibited, e.g. the saw may not be used as a means of transport or as an improvised lifting winch.

The machine is suitable for wet and dry cutting. A dust removal system must be used for dry cutting. Special dust hoods are available on request.

The equipment may be lifted by crane only at the lifting points provided.

Do not cut materials in which the cutting process may produce hazardous or explosive dust or vapors.

Do not cut easily flammable materials.

3.5 Drive principle

The sawing wire is passed round the object to be cut, over guide pulleys and round the drive wheel, forming an endless loop when the ends of the wire are connected together. Rotation of the drive wheel sets the endless loop in motion and linear movement of the drive unit causes the sawing wire to be drawn through the object as cutting progresses.

3.6 Saw advance and wire storage

Wire advance works according to the block and tackle principle. The advance movement, causing the wire to be drawn in, is achieved by the wire storage pulleys being pushed apart by a pneumatic cylinder. Accordingly, the drive unit is mounted on a moving carriage.

The length of wire that can be stored in the machine depends on whether the wire is rigged around one or two sets of pulleys and whether the optional wire store extension is used.

3.7 The functions of the wire guidance system

With the aid of the adjustable pivoting pulleys, the line of the sawing wire between the machine and the pivoting pulley mounted on the object to be cut can be brought exactly into alignment. In flush cutting applications, the pivoting pulleys can be allowed to pivot freely with the wire as the distance between the wire entry and exit points decreases while the cut progresses.

3.8 Guards or protective covers

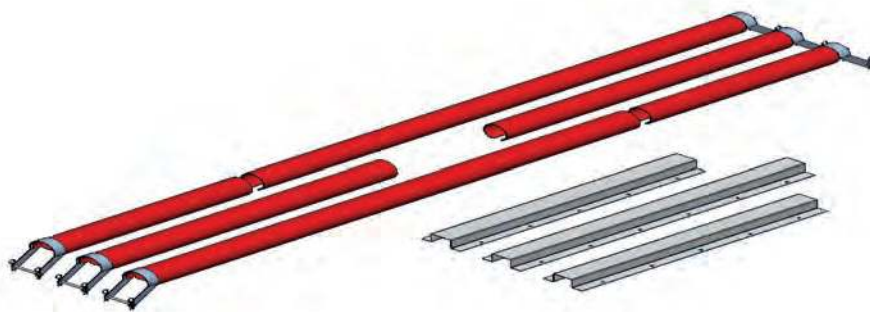

Guards must be fitted before the wire saw is operated and the guards must remain fitted during the entire period the machine is in operation. Check that the guards or covers are fitted correctly before beginning the work.

If fitting guards is not possible, it is essential to ensure that no one enters or remains in the danger area during operation of the equipment.

4 Technical data

4.1 Technical data – control unit

Rated voltage	400 V
AC frequency	50 / 60 Hz
Mains connection (phase requirements)	3P+N+PE / 3P+PE
Rated current	17 A
Mains fuse rating	32 A
Maximum input power	11 kW
Minimum generator output	40 kVA (32 A)
Ground fault circuit interrupter in supply	30 mA (type A)
Control unit protection class	IP 54
Power outlet	230 V / 10 A
Ambient temperature (storage)	-15 °C ... 50 °C
Ambient temperature (operation)	0 °C ... 45 °C
Leakage current	≤ 10 mA
Insulation resistance	at least 300 kΩ
Weight of the control unit	68.5 kg

4.2 Technical data – drive unit

Motor power	9.4 kW
Engine speed	0 /min ... 2,060 /min
Cutting speed	0 m/s ... 29 m/s
Drive wheel diameter	280 mm
Cooling water flow rate (30 °C)	4 ℓ/min
Cooling water temperature	4 °C ... 30 °C
Minimum / maximum cooling water pressure	4 bar ... 6 bar
Ambient temperature (storage)	-15 °C ... 50 °C
Ambient temperature (operation)	0 °C ... 45 °C
Weight of the drive and wire storage unit	81.2 kg
Protection class	IP 65

4.3 Compressed air supply

Minimum / maximum pressure (compressed air supply)	6 bar ... 8 bar
Air flow rate (compressed air supply)	205 ℓ/min

4.4 Length of the internal supply lines

Length of compressed air line (short)	1 m
Length of compressed air line (long)	7 m
Length of cooling water supply line	10 m
Length of power cable	7 m

4.5 Noise information

Noise values

Typical A-weighted sound power level to ISO 3744	103.7 dB (A)
Typical A-weighted emission sound pressure level to ISO 11202 (at a distance of 3 meters)	80.2 dB (A)

4.6 Dimensions

4.6.1 Dimensions of the drive and wire storage unit

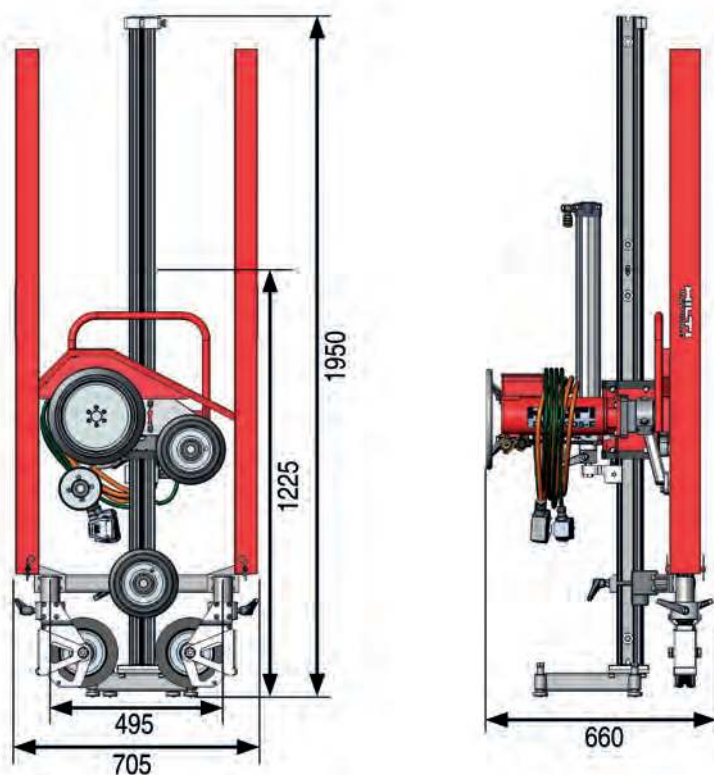

The dimensions of the drive and wire storage unit are shown in the diagram.

4.6.2 Dimensions of the control unit

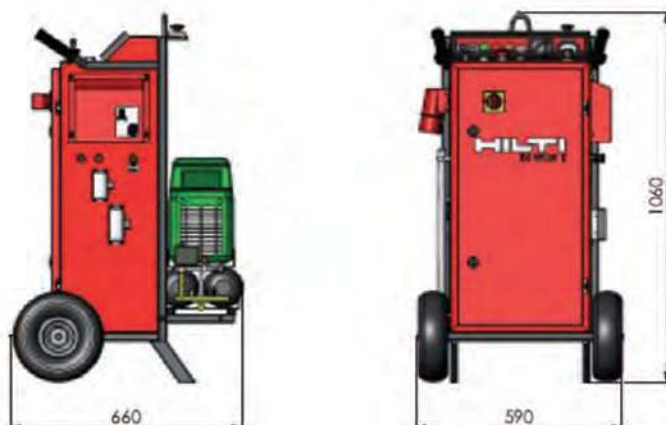

The dimensions of the control unit are shown in the diagram.

4.6.3 Dimensions of the pulley stand

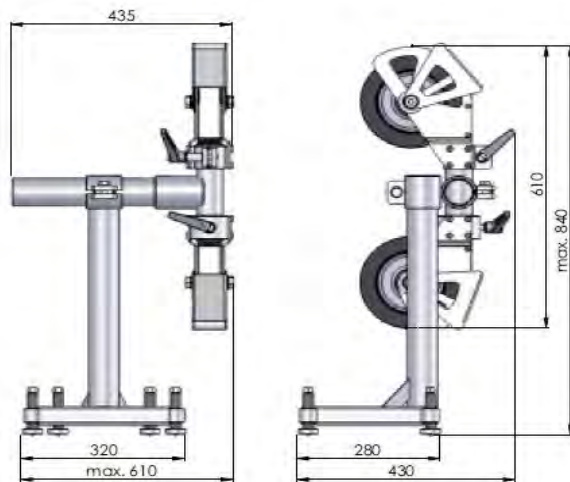

The dimensions of the pulley stand are shown in the diagram.

5 Operation

5.1 Preparations at the workplace

5.1.1 Marking the cuts to be made

The parts to be cut out are usually marked by the client.

If necessary, make dividing cuts to adjust the maximum size and weight of the concrete blocks to the prevailing conditions (i.e. the lifting capacity of the crane or the maximum permissible floor loading capacity and size of doors).

5.1.2 Planning the wire guidance system and cutting configuration

Thorough training and experience are the most important prerequisites for optimum planning of the cutting configuration and wire guidance system.

Long lengths of wire in contact with the object to be cut or cutting in a very flat arc reduce sawing performance.

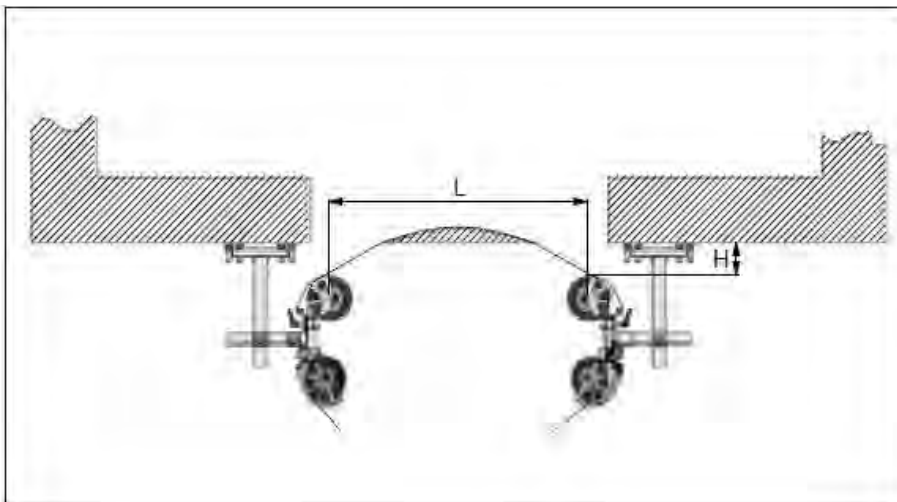

The rule of thumb is: Pulley distance $H = \text{cutting length } L \times 0.2$.

For a cutting length of 1.5 meters the pulley distance should thus be 0.3 meters ($1.5 \text{ m} \times 0.2 = 0.3 \text{ m}$).

When planning the wire guidance system, make sure that the wire contact length does not exceed 2 meters.

Arrange the cutting sequence so that the wire cannot become trapped by parts that are cut away.

5.1.3 Examples of applications

The following examples illustrate the most common applications.

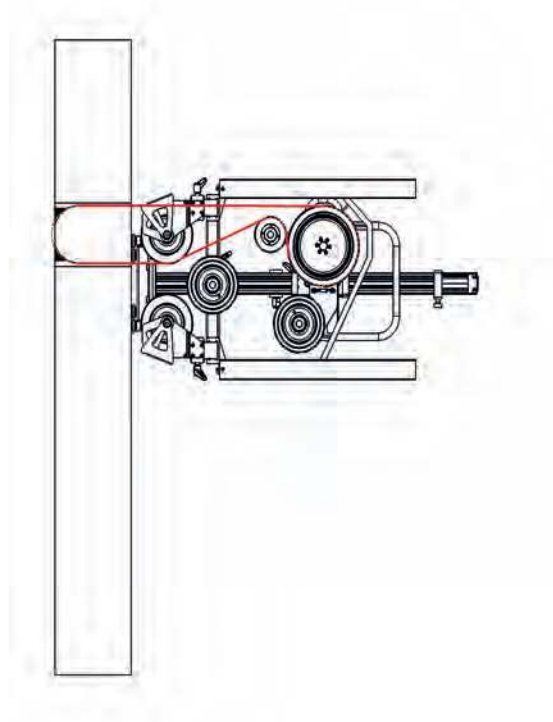

Horizontal and vertical cuts, cutting length 20 to 40 cm

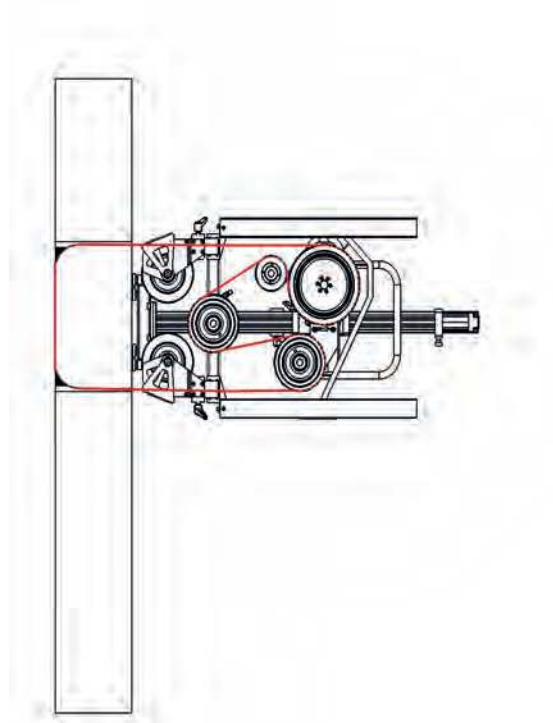

Horizontal and vertical cuts, cutting length 40 to 70 cm

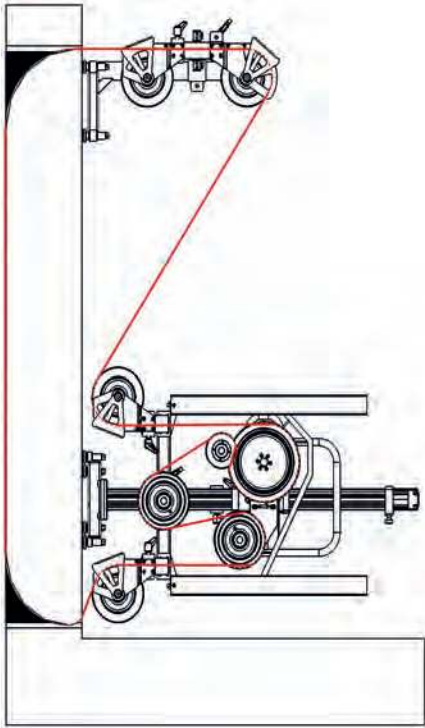

Horizontal and vertical cuts, cutting length 70 to 200 cm

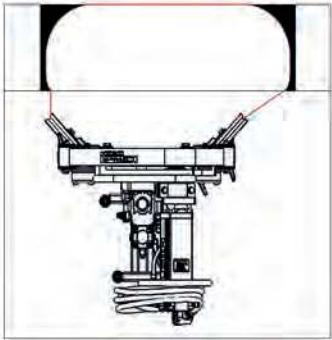

Flush cuts, cutting length 50 to 100 cm

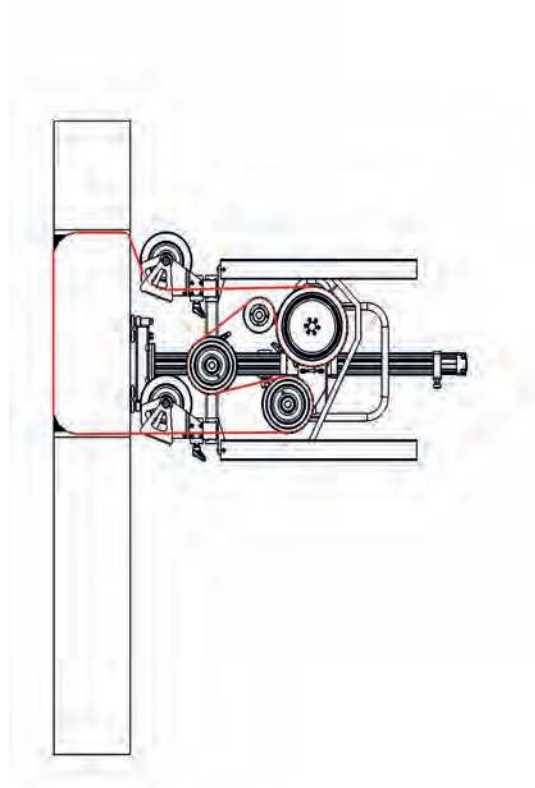

Cutting beams or columns, cutting length 30 to 100 cm

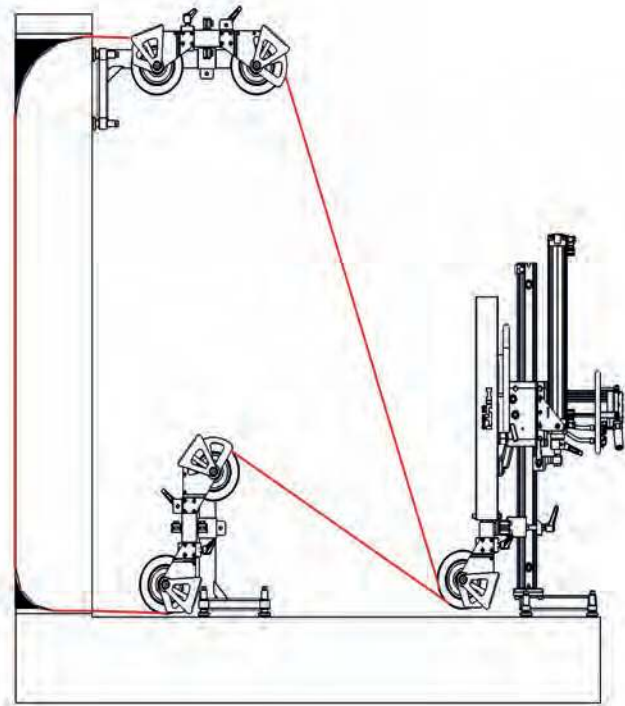

Horizontal and vertical cuts, cutting length 50 to 200 cm

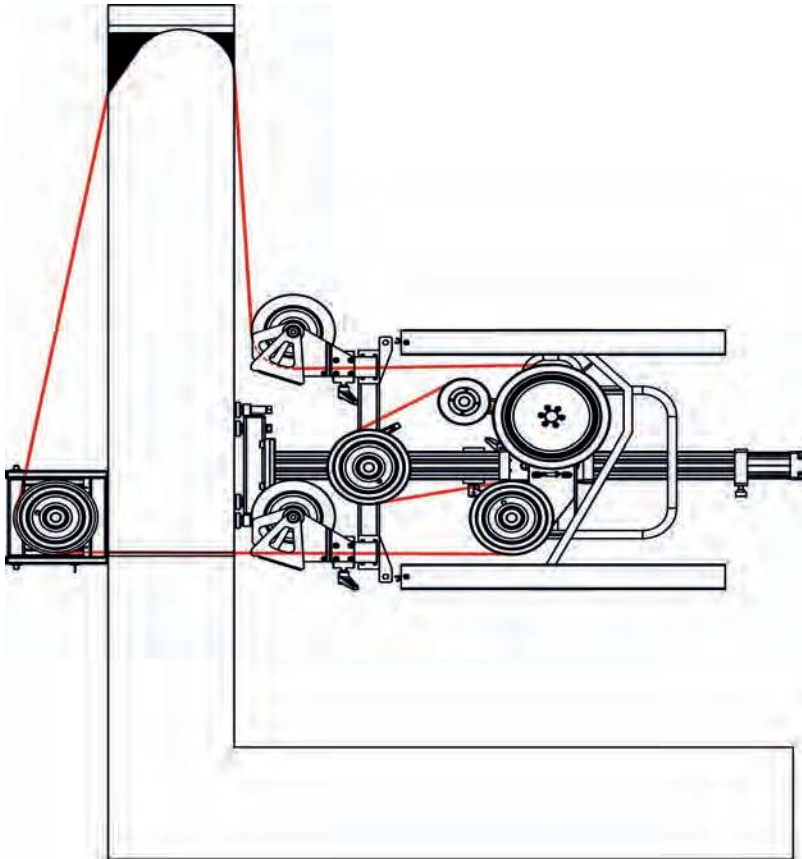

Horizontal or vertical cuts using the transverse cutting technique

5.1.4 Determining wire storage and wire length requirements

Estimating wire storage requirements: Thickness of object in cutting direction x 2

Estimating wire length requirements: Wire length required for minimum configuration of the saw + length of tension side + 2 x thickness of object cut + length of cut + length of slack side

5.1.5 Safety aspects to be clarified

Is the cutting area free from hazardous pipes or cables (gas, water, electricity, etc.)?

Have the effects of the cutting work on the stability of the structure been clarified and are all supports capable of taking up the resulting loads?

Can the possibility of hazards or damage as a result of the cooling water used be ruled out?

Can safety measures be implemented in order to ensure that no persons can be injured or property and equipment damaged by falling objects or debris that may fly off?

Can the parts of the structure cut away be removed safely in a controlled operation and disposed of?

Does the electric supply and water supply available for use meet the specified requirements?

Is the necessary equipment in the appropriate specification available for use?

Has the work to be carried out been approved in full by the site engineer or architect?

5.1.6 Extension cables / conductor cross section

Use only extension cables of a type approved for the application and with conductors of adequate gauge (cross section). Conductor cross section means the cross-sectional area of a single conductor. In accordance with EN 61029-1, conductor cross section must be at least 1,5mm² for 16 A, 4 mm² for 32 A and 10 mm² for 63 A.

Smaller conductor cross sections and long cables lead to a drop in voltage and cause the extension cable to overheat.

Before use, extension cables must always be unrolled from the reel.

5.1.7 Cooling water supply

At a water temperature of 30 °C a water flow rate of approx. 4 l/min is necessary to cool the drive unit.

The machine's automatic cut-out will be activated in the event of inadequate cooling.

Use only clean cooling water.

Where pressure in the water supply line is low, a non-return valve should be fitted in order to prevent dirty water finding its way into the water supply.

5.2 Setting up the system

5.2.1 Drilling the through holes



The location and positioning of the through holes has a direct influence on cutting accuracy.

On very thick walls or where cutting tolerances are minimal, we recommend use of rig-based diamond coring machine for drilling the holes.

On thin walls or where cutting tolerances are greater, a rotary hammer can be used to drill the holes.

We recommend a drilling diameter of at least 16 mm, but the diameter should be at least 4 % of the thickness of the object to be cut.

5.2.2 Fastening the base plate



WARNING

Warning Use of vacuum pads for fastening the base plate is not permissible.

- ▶ Vacuum pad fastening is not permissible under any circumstances.

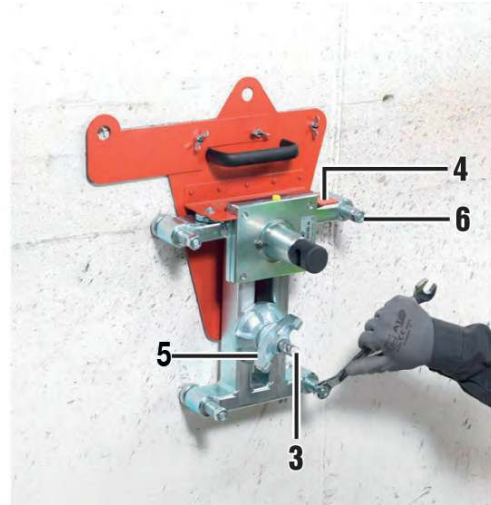
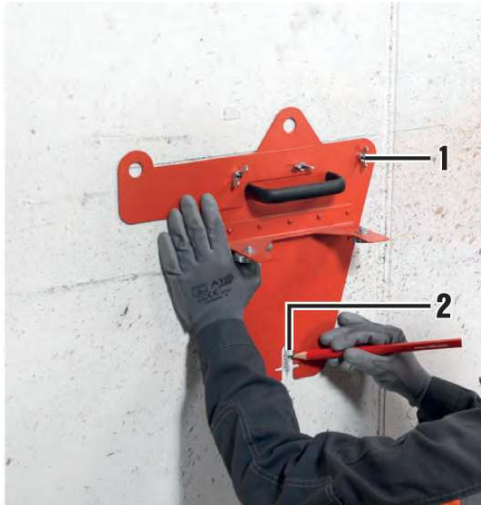

1. Hold the template in the desired position (1).
2. Use the template to mark the position of the anchor hole (2).
3. Drill the anchor hole (2), clean the hole and insert and set the anchor in accordance with the applicable instructions.
4. Screw in the clamping spindle (3) as far as it will go.
5. Attach the template (4) to the base plate.
6. Bring the base plate and template into position and then screw on the clamping nut (5).
7. Adjust the alignment of the baseplate and then tighten the clamping nut (5) and the leveling screws securely.

5.2.3 Fastening the guidance unit



1. Fit the tapered connector into the guide rail (1) and insert the eccentric pin (2) fully.
2. Tighten the eccentric pin by turning it clockwise (3).

5.2.4 Fitting the optional wire storage extension



WARNING

Caution Extending the wire storage capacity

- ▶ Use only the specified accessory components to extend wire storage capacity and never extend the storage unit beyond the maximum permitted length of 2 meters.

1. Insert the tapered connector and secure it with the eccentric pin.

2. Fit the wire storage extension and secure it with the eccentric pin.

5.2.5 Fitting the end stop



WARNING

Caution The end stop must be fitted correctly.

- ▶ Do not, under any circumstances, use the saw without a correctly fitted end stop..



- ▶ Fit the end stop (1).

5.2.6 Fitting the pulley bearer



1. Attach the pulley bearer. In doing so, pay attention to the distance from the wall.
2. Close the retaining plate (1) and tighten the clamping lever (2) securely.

5.2.7 Fitting the drive unit



1. Pull the clamping bolt (1) out of the carriage.
2. Insert the tensioning hook in the guide slot.
3. Push in the clamping bolt (1) and turn it clockwise until tight (2). Fit the end stop.

5.2.8 Connecting the compressed air lines to the pneumatic cylinder



- ▶ Connect the compressed air lines (1) to the pneumatic cylinder (2).

5.2.9 Rigging, connecting and pulling the wire through by hand



WARNING

Caution Release the advance unit lock only when the advance pressure cylinder is not under pressure.

- ▶ The advance unit lock and piston rod clamp may be released only when you have made sure that there is no pressure in the advance pressure cylinder.



1. First pass the sawing wire through the object to be cut and then round off any corners or edges in the path of the wire by pulling the wire back and forward manually until it can be moved easily by hand.
2. Feed the sawing wire through the hollow axles (1) of the pulley stands and then through the hollow axles of the pulley bearer on the wire saw.
3. Place the sawing wire on the pulleys (2) and on the drive wheel (3) and then tension the wire slightly by moving the drive unit (release the piston rod lock).
4. Lock the drive unit (3) in position.

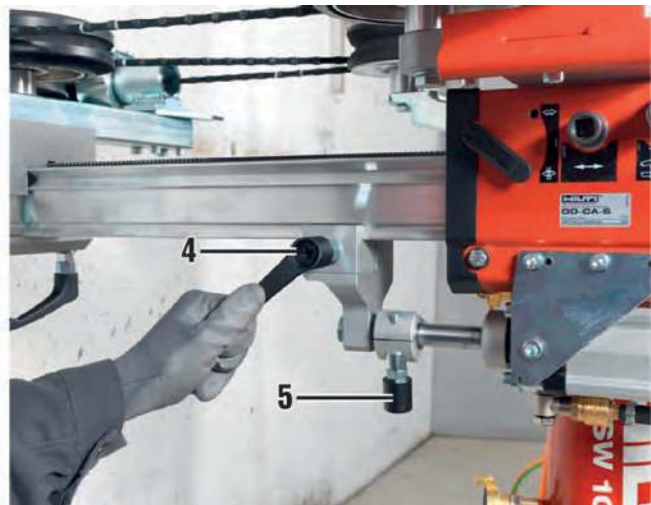

5. Release the return stop (4), push the piston rod all the way in and then lock the piston rod and return stop (5).
 - ◁ The return stop prevents slackening of the sawing wire due to elastic movement of the piston rod when starting the saw.
6. After securing the return stop, release the advance lock.

5.2.10 Fitting the guards



WARNING

Caution The end stop must be fitted correctly.

- ▶ Do not, under any circumstances, use the saw without a correctly fitted end stop..



WARNING

Caution Using long guards

- ▶ The long guards must be used when the wire storage extension is fitted. The standard guards supplied with the machine must otherwise be used.



Note

The emergency stop button must be pressed in before anyone enters the safety area.



1. Bring the guard into position (1).
2. Secure the guard with the retaining pin (2).

5.2.11 Connecting the compressed air lines to the control unit

- ▶ Connect the compressed air lines to the compressor and control unit.



Note

The emergency stop button must be pressed in before connecting the air lines.

5.2.12 Fitting the water supply



1. Connect the water supply line to the drive unit (3).
2. Connect the hoses for the cooling water lances (1, 2) to the water distributor.
3. Mount the water lances and position the nozzles (2) at the wire entry points.

5.2.13 Connecting the power cable and control cable to the control unit



- ▶ Connect the power cable and control cable and secure the plugs.

5.3 Operation and sawing

5.3.1 Setting the starting cutting pressure



1. Set the saw advance pressure on the control unit to the recommended value, tension the wire by adjusting the advance control valve and check that the sawing wire can be pulled easily through the kerf by hand.
2. Set the advance pressure (1).
3. Operate the advance control valve (2).

5.3.2 Starting



WARNING

Caution Switch off the drive if the sawing wire slips.

- ▶ Switch the main drive off right away if the wire doesn't move immediately after starting. Slippage of the sawing wire causes damage to the drive wheel.



WARNING

Note Full use cannot be made of the electric supply power available if the effective sawing advance pressure is set too low.

- ▶ When cutting in a shallow arc, full use cannot be made of the electric supply power available due to the low effective sawing advance pressure.



1. Switch on the main drive (1) and allow the sawing wire to start running.
2. Use the speed regulator (2) to increase the speed of the wire drive and, at the same time, also increase the advance pressure.

5.3.3 Readjusting saw advance at end of stroke



WARNING

Caution Release the piston rod lock only when the advance pressure cylinder is not under pressure.

- ▶ Release the piston rod lock only after you have checked to make sure that the advance pressure cylinder is not under pressure.



1. Switch off the drive unit and press the emergency stop button when the tensioning cylinder reaches the end of its stroke. Then lock the advance movement at the carriage (1).
2. Use the control valve to select the direction of advance (2).
3. Release the return stop (5) and the piston rod lock (3). Push the piston rods (4) in by hand.

4. Clamp the piston rod lock (3), secure the return stop (5) and release the advance lock (1).

6 Cleaning, maintenance and repair

6.1 Cleaning

WARNING

Caution Unplug the electric supply cable.

- ▶ Unplug the electric supply cable from the power outlet and disconnect the compressed air supply line.

WARNING

Caution Keep gripping surfaces clean and dry.

- ▶ Keep the machine, especially its grip surfaces, clean and free from oil and grease. Do not use cleaning agents containing silicone.

Thorough, regular cleaning and maintenance of the equipment helps ensure smooth, easy movement of moving parts and controls and protects the equipment from damage caused by a build-up of slurry and dirt.

We recommend that the wire saw and pulley stands are cleaned quickly after each cut. Pay particular attention to the running surfaces and the toothed rack on the guide rail as well as all moving parts and operating controls.

Use plenty of water and a medium-hard brush to clean the entire system at the end of the day, with the exception of the electrically powered components such as the compressor and the control unit. Plan this cleaning work as part of your daily work schedule.

6.2 Care

WARNING

Caution Allow the machine to warm up before use at low temperatures.

- ▶ At temperatures below freezing, allow the machine to warm up slowly before operation under load and blow all water out of the cooling system before long pauses between use.

After cleaning, check that all parts are undamaged and that they operate smoothly, easily and function correctly. Check that the drive unit, when under no load, can be moved smoothly over its entire stroke with an air pressure of 1 bar. In the interest of avoiding accidents and expensive consequential damage, damaged or incorrectly functioning parts must be replaced before further use of the machine.

Spraying the cleaned machine with concrete form release agent reduces the amount of dirt adhering to the surfaces and makes subsequent cleaning easier.

The air filters located at top right and on the floor inside the control unit should be checked for cleanliness at regular intervals and replaced if necessary.

7 Troubleshooting

7.1 Troubleshooting

Trouble or fault	Possible cause	Action to be taken
The drive wheel / sawing wire don't begin to rotate.	The wire passes round too many and/or too acutely angled (< 90°) concrete edges.	<ul style="list-style-type: none"> ▶ Chisel off or round off the corners and pull the wire through by hand until it moves easily. ▶ Reduce the angle at corners by mounting additional return pulleys. ▶ Reduce the number of corners by changing the wire guidance system.
	Initial tension on the wire is too high.	<ul style="list-style-type: none"> ▶ Reduce the initial tension by reducing the pressure.
	The length of cut or contact is too long.	<ul style="list-style-type: none"> ▶ Divide the cut into several individual sections. ▶ Reduce the contact length by mounting additional return pulleys.
	The wire was fitted the wrong way round (opposite to specified direction of travel).	<ul style="list-style-type: none"> ▶ Check the direction of travel and change if necessary (leading edge of bead is slimmer).
	New wire jams in an existing, narrower kerf.	<ul style="list-style-type: none"> ▶ Use a thinner wire.
	The sawing wire is damaged.	<ul style="list-style-type: none"> ▶ Repair or replace the sawing wire if it is kinked in places. ▶ Check that the connector is fitted corresponding to its direction of travel and that it's thinner than the sawing wire. Fit it the other way round if necessary. ▶ Check that the wire is always used in the same direction of travel. Change the direction of travel if necessary.
	The sawing wire is kinked in places.	<ul style="list-style-type: none"> ▶ Repair or replace the sawing wire.
	The connector is facing the wrong direction.	<ul style="list-style-type: none"> ▶ Change the direction of travel.
	The connector is thicker than the sawing wire.	<ul style="list-style-type: none"> ▶ Use a thinner connector.

Trouble or fault	Possible cause	Action to be taken
The drive wheel / sawing wire don't begin to rotate.	The sawing wire is used the wrong way round (direction of travel).	<ul style="list-style-type: none"> ▶ Change the direction of travel.
The drive wheel slips / the wire is not driven.	The diamond wire is too slack.	<ul style="list-style-type: none"> ▶ Set the advance control valve to "advance". ▶ Increase the initial tension by increasing the pressure. ▶ Set the cylinder back to the end of stroke and the carriage back to the end stop. ▶ Check that the guide carriage moves easily along the rail. If necessary, clean the guide surfaces, rack and rollers.
	The drive wheel is too badly worn.	<ul style="list-style-type: none"> ▶ Replace the drive wheel.
The wire jumps off the drive wheel or guide pulley when starting the saw.	The return stop has not been set.	<ul style="list-style-type: none"> ▶ Push the return stop all the way toward the cylinder and clamp it securely.
	The guide pulleys are not aligned exactly.	<ul style="list-style-type: none"> ▶ Align the guide pulleys exactly with each other.
Very little or no sawing progress.	The power drawn by the machine is too low.	<ul style="list-style-type: none"> ▶ Set up the saw to cut in a tighter arc.
	The length of cut or wire in contact is too long.	<ul style="list-style-type: none"> ▶ Use a release pulley to reduce the length of wire in contact. ▶ Reduce cutting length / divide the cut into several individual sections.
	Stiff movement of the carriage on the wire guidance unit.	<ul style="list-style-type: none"> ▶ Check that the carriage moves easily (smooth movement \leq 1 bar air pressure) and clean the guide surfaces, rack and rollers if necessary.
	The wire beads are polished, worn or poorly sharpened.	<ul style="list-style-type: none"> ▶ Sharpen the sawing wire. ▶ Replace the sawing wire.
	The advance pressure cylinder has reached the end position or the carriage is at the end stop.	<ul style="list-style-type: none"> ▶ Reposition the end stop. ▶ Readjust the cylinder and fit the wire storage extension.
Excessively high diamond bead wear.	Cutting speed or, respectively, wire drive speed is too low.	<ul style="list-style-type: none"> ▶ Increase the cutting speed, i.e. wire drive speed.

Trouble or fault	Possible cause	Action to be taken
Excessively high diamond bead wear.	Too little cooling / flushing water (dust generated).	<ul style="list-style-type: none"> ▶ Direct the water exactly onto the wire and into the kerf. ▶ Increase the water flow.
	Wire tension is too high for the length of cutting contact.	<ul style="list-style-type: none"> ▶ Increase the length of cut and / or reduce the wire tension.
	Very abrasive material.	<ul style="list-style-type: none"> ▶ Use a different wire specification.
Uneven / one-sided wear of the sawing wire.	The wire was not twisted before connecting the ends together.	<ul style="list-style-type: none"> ▶ Twist the diamond wire approx. half a turn counterclockwise (looking at the end of the wire) per meter length of wire before connecting the ends.
The diamond wire collapses, i.e. the beads are pushed together on the wire.	Inadequate cooling of the sawing wire	<ul style="list-style-type: none"> ▶ Make sure that sufficient water reaches the points where the wire is cutting. ▶ Stop cutting and allow to cool.
	The diamond wire jams suddenly while sawing.	<ul style="list-style-type: none"> ▶ Prevent movement of the part being cut. ▶ Observe the correct cutting sequence. ▶ Remove loose material from the kerf.
The diamond wire is pulled out of the crimped connector.	Wrong or inadequate crimping pliers used.	<ul style="list-style-type: none"> ▶ Use the crimping pliers recommended by the connector manufacturer.
	The crimping jaws of the pliers are worn.	<ul style="list-style-type: none"> ▶ Renew the crimping jaws.
	The wire end was not pushed far enough into the connector.	<ul style="list-style-type: none"> ▶ Push the wire into the connector up to the first stop. ▶ Cut the wire end exactly at right angles and remove an adequate length of the plastic coating.
	The connector was crimped too far back or too far forward.	<ul style="list-style-type: none"> ▶ Crimp the connector exactly at the position specified by the connector manufacturer.

Trouble or fault	Possible cause	Action to be taken
Wire breakage immediately before or after the connector.	Fatigue breakage of the loadbearing wire.	<ul style="list-style-type: none"> ▶ Reduce stress through use of flexible connectors. ▶ Use only one connector per endless wire loop if possible. ▶ Use a new wire if breakages occur in quick succession.
The diamond wire begins to vibrate heavily while sawing.	Wire tension is too low or too high.	▶ Optimize the tension by adjusting the pressure.
	The guide pulleys are not aligned exactly.	▶ Adjust the pulleys to bring them exactly into alignment.
	The guide pulleys are too far apart (length of unsupported wire is too long).	<ul style="list-style-type: none"> ▶ Reduce the length of unsupported wire by fitting additional pulley stands. ▶ Position the wire saw closer to where the cut is being made.
	The guide pulley is worn, out of round or a stone is stuck in the guide groove.	<ul style="list-style-type: none"> ▶ Check that the pulleys run exactly true and replace them if necessary. ▶ Check that the guide grooves are free of foreign matter and clean them if necessary.
The air compressor doesn't start.	Not connected to the electric supply.	▶ Connect to the electric supply.
	The compressor is not switched on.	▶ Switch the compressor on.
The air compressor can't build up any pressure.	The tank of the compressor connected to the control unit is empty.	▶ Disconnect the air hose from the compressor and allow the compressor to run until it is switched off by the pressure valve. Then reconnect the air hose.
The machine doesn't start, the green "ready" lamp doesn't light.	The electric supply is dead – no voltage.	▶ Check the main supply fuse at the site distribution box.
	The main switch is in the "Off" position.	▶ Switch on at the main switch.

Trouble or fault	Possible cause	Action to be taken
The machine doesn't start, the green "ready" lamp doesn't light.	One phase is missing or its voltage is too low.	<ul style="list-style-type: none"> ▶ Check the three phases individually. ▶ Check the extension cable, plug and power outlet for faults or loose contacts.
	The fuse in the control unit has blown.	<ul style="list-style-type: none"> ▶ Replace the blown fuse (spare fuses located in the control unit).
The machine doesn't start, green "ready" lamp and red "fault" lamp both light.	The drive power cable or the control cable is not plugged into the control unit.	<ul style="list-style-type: none"> ▶ Connect the cable.
	The thermal protective motor cut-out has switched the machine off due to overheating.	<ul style="list-style-type: none"> ▶ Use more or cleaner cooling water.
	The converter overload protection device has switched the machine off.	<ul style="list-style-type: none"> ▶ Do not overload the machine. ▶ Shade the control unit from the sun. ▶ Check that the control unit cooling system is working and replace the filter if necessary.
The machine doesn't start even though the green "ready" lamp lights.	The emergency stop button is pushed in.	<ul style="list-style-type: none"> ▶ Release the emergency stop button.
230 V power outlet doesn't work.	No neutral conductor in the electric supply (3P + N + PE)	<ul style="list-style-type: none"> ▶ Check the electric supply.
	The automatic circuit breaker has tripped.	<ul style="list-style-type: none"> ▶ Eliminate the fault and reset the automatic circuit breaker.
The ground fault circuit interrupter is tripped.	Insulation fault	<ul style="list-style-type: none"> ▶ Have the machine and supply cables checked by a trained electrical specialist.
	Total leakage current exceeds the triggering threshold of the ground fault circuit interrupter.	<ul style="list-style-type: none"> ▶ Disconnect other appliances from the electric supply you are using (especially appliances with HF drive).

8 Disposal

8.1 Disposal

 Most of the materials from which **Hilti** tools and appliances are manufactured can be recycled. The materials must be correctly separated before they can be recycled.

In many countries, your old tools, machines or appliances can be returned to **Hilti** for recycling. Ask **Hilti** Service or your Hilti representative for further information.



- ▶ Disposal of electric tools or appliances together with household waste is not permissible.

8.2 Recommended pretreatment for disposal of drilling slurry



Note

The disposal of drilling slurry directly into rivers, lakes or the sewerage system without suitable pretreatment presents problems of an environmental nature. Ask the local public authorities for information about current regulations.

1. Collect the drilling slurry (e.g. using a wet-type industrial vacuum cleaner).
2. Allow the drilling slurry to settle and dispose of the solid material at a construction waste disposal site (addition of a flocculent may accelerate the settling process).
3. The remaining water (alkaline, pH value > 7) must be neutralized by the addition of an acidic neutralizing agent or diluted with a large volume of water before it is allowed to flow into the sewerage system.

9 Manufacturer's warranty

9.1 Manufacturer's warranty

- ▶ Please contact your local **Hilti** representative if you have questions about the warranty conditions.

EC Declaration of Conformity | UK Declaration of Conformity



Manufacturer:
Hilti Corporation
Feldkircherstraße 100
9494 Schaan | Liechtenstein

Importer:
Hilti (Gt. Britain) Limited
1 Trafford Wharf Road, Old Trafford
Manchester, M17 1BY

DSW 1005-E (01)

Serial Numbers: 1-9999999999

2006/42/EC | Supply of Machinery (Safety) Regulations 2008

EN 60204-1:2018

EN 15027:2007 + A1:2009

2014/30/EU | Electromagnetic Compatibility Regulations 2016

EN 55014-1:2017 +
A11:2020

EN 55014-2:2015

2011/65/EU | The Restriction of the Use of Certain Hazardous Substances in Electrical and Electronic Equipment Regulations 2012

EN 55011:2016 + A1:2017

EN 61000-3-11:2019

EN 61000-3-12:2011

Dr. Tahar Zrilli
Head of Quality and Process Management
Business Area Electric Tools & Accessories

Schaan, 09.08.2021

Johannes Wilfried Huber
Senior Vice President
Business Unit Diamond



Hilti Corporation
LI-9494 Schaan
Tel.:+423 234 21 11
Fax:+423 234 29 65
www.hilti.com

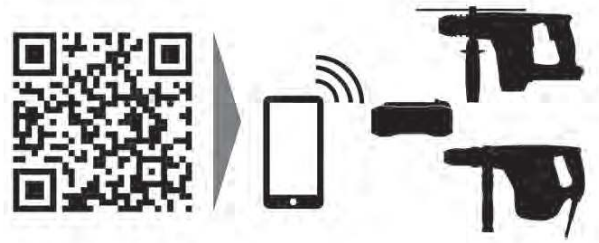

2154460