

# HILTI

safe  
set



[qr.hilti.com/manual/  
?id=2334935](http://qr.hilti.com/manual/?id=2334935)

English  
Français  
Español  
Português



Hilti HIT-HY 200-A V3  
Hilti HIT-HY 200-R V3



(A, B)

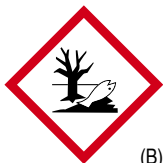

(B)

## Warning





















**Contains:** hydroxypropylmethacrylate (A)  
2,2'-(m-tolylimino)diethanol (A) 1,4-Butandiol-dimet-  
hacrylat (A) dibenzoyl peroxide (B) May cause an  
allergic skin reaction. (A, B) Causes serious eye  
irritation. (B) Very toxic to aquatic life with long lasting  
effects. (B)



PDF



Latest version available online, use QR code in front page / Dernière version disponible en ligne, utilisez le code QR en première page / Última versión disponible en línea, use el código QR en portada / Última versão disponível online, use o código QR na primeira página

<b>1</b>		<b>7</b>		<b>13</b>		<b>19</b>	
<b>2</b>		<b>8</b>		<b>14</b>		<b>20</b>	
<b>3</b>		<b>9</b>		<b>15</b>		<b>21</b>	
<b>4</b>		<b>10</b>		<b>16</b>			
<b>5</b>		<b>11</b>		<b>17</b>			
<b>6</b>		<b>12</b>		<b>18</b>			

**en** 1 Uncracked concrete; 2 Cracked concrete; 3 Grout-filled CMU; 4 Dry base material; 5 Water saturated base material; 6 Waterfilled borehole in concrete; 7 Threaded rod, Threaded sleeve; 8 Rebar; 9 HIT-Z, HIT-Z-R; 10 Hammer drilling; 11 Hollow drill bit; 12 Diamond coring; 13 Roughening tool; 14 Temperature of base material; 15 cartridge temperature; 16 Working time; 17 Curing time; 18 Roughening time; 19 Blowing time; 20 ECO mode; 21 Automatic filter cleaning

**fr** 1 Béton non lézardé; 2 Béton lézardé; 3 CMU rempli de mortier; 4 Matériau de base sec; 5 Matériau de base saturé d'eau; 6 Trou dans le béton rempli d'eau; 7 Tige filetée, Douille filetée; 8 Armature métallique; 9 HIT-Z HIT-Z-R; 10 Percage avec percussion; 11 Foret creux; 12 Forage au diamant; 13 Outil de rugosification; 14 Température du matériau support; 15 Température de la cartouche; 16 Temps de manipulation; 17 Temps de durcissement; 18 Temps de rugosification; 19 Temps de soufflage; 20 Mode ECO; 21 Nettoyage automatique du filtre

**es** 1 Hormigón no fisurado; 2 Hormigón fisurado; 3 CMU relleno con mortero; 4 Superficie de trabajo seca; 5 Superficie de trabajo saturada de agua; 6 Taladro lleno de agua en hormigón; 7 Varilla roscada, Manguito roscado; 8 Barras corrugadas para armado; 9 HIT-Z HIT-Z-R; 10 Taladro con percusión; 11 Taladro con broca hueca y aspiración; 12 Taladro con diamante; 13 Útil de rugosidad; 14 Temperatura de la superficie de trabajo; 15 Temperatura del cartucho; 16 Tiempo de ajuste; 17 Tiempo de fraguado; 18 Tiempo de rugosidad; 19 Tiempo de soplado; 20 Modo ECO; 21 Limpieza automática del filtro

**pt** 1 Betão não fissurado; 2 Betão fissurado; 3 CMU preenchido com argamassa; 4 Material base seco; 5 Material base saturado de água; 6 Furo em betão cheio de água; 7 Barra roscada, Casquilho roscado; 8 Ferros de armadura; 9 HIT-Z HIT-Z-R; 10 Perfurar de martelo; 11 Broca de coroa oca; 12 Perfurar com equipamento diamantado; 13 Ferramenta de rugosidade; 14 Temperatura do material base; 15 Temperatura do cartucho; 16 Tempo de trabalho; 17 Tempo de cura total; 18 Tempo de rugosidade; 19 Tempo de sopro; 20 Modo ECO; 21 Limpeza automática do filtro

**AR** Hilti Argentina S.R.L. Profesor Manuel García 4760 B1605 BIB - Munro AR-Buenos Aires Tel +54 11 4721 4400

**AU** Hilti (Aust.) Pty. Ltd. Level 5, 1G Homebush Bay Drive Rhodes N.S.W. 2138 Tel +61 2 8748 1000

**BR** Hilti do Brasil Comercial Ltda Al. Rio Negro, 500 -Torre A, 9º andar 06454-000 Barueri, SP - Brasil Tel +55 11 4134 9000

**CA** Hilti (Canada) Corp. 2360 Meadowpine Boulevard Mississauga, Ontario L5N 6S2 Tel +1 905 813 9200

**CL** Hilti Chile Ltda. Av. Apoquindo 4501, piso 13 Las Condes 7550000 Santiago Tel +562 655 3000

**CR** Superba S.A. 200 Mts. Oeste de Matra la Uruca CR-San José Tel +506 2255 1044













**CO** CO Hilti Colombia S.A.S. Calle 99 # 10-57, Piso 5 Chicó Norte Bogotá D.C., Colombia +57 1 5190001

**MX** Hilti Mexicana, S.A. de C.V. Jaime Balmes 8, Oficina 102, 1er Piso Col. Los Morales Polanco Del. Miguel Hidalgo MEX-Mexico City 11510 Tel +56 2 2655 3000













**PR** Hilti Perú S.A. Perú S.A. Av. Javier Prado Este N°499 Int. 1103 Urbanización - Golf Los Inkas, Santiago de Surco. Tel +51 0800 44584





**US** Hilti, Inc. Legacy Tower, Suite 1000 7250 Dallas Parkway TX 75024 Plano - USA Tel +52 01 800 61 44584

**HY 200-A V3**

		HIT-V, HAS-U, HAS, HAS-E HIS-N Rebar 		HIT-Z 	
[°C]	[°F]	 $t_{work}$	 $t_{cure}$	 $t_{work}$	 $t_{cure}$
-10...-5	14...23	1,5 h	7 h		
-4...0	24...32	50 min	4 h		
1...5	33...41	25 min	2 h		
6...10	42...50	15 min	75 min	15 min	75 min
11...20	51...68	7 min	45 min	7 min	45 min
21...30	69...86	4 min	30 min	4 min	30 min
31...40	87...104	3 min	30 min	3 min	30 min

**HY 200-R V3**

		HIT-V, HAS-U, HAS, HAS-E HIS-N Rebar 		HIT-Z 	
[°C]	[°F]	 $t_{work}$	 $t_{cure}$	 $t_{work}$	 $t_{cure}$
-10...-5	14...23	3 h	20 h		
-4...0	23...32	90 min	8 h		
1...5	32...41	45 min	4 h		
6...10	41...50	30 min	2,5 h	30 min	2,5 h
11...20	50...68	15 min	1,5 h	15 min	1,5 h
21...30	69...86	9 min	1 h	9 min	1 h
31...40	87...104	6 min	1 h	6 min	1 h

			
$h_{ef}$ [inch]	$h_{ef}$ [mm]	 $t_{roughen\ max}$	 $t_{blowing\ min}$
0 ...4	0 ... 100	10 sec	30 sec
4.01 ...8	101 ... 200	20 sec	40 sec
8.01 ...12	201 ... 300	30 sec	50 sec
12.01 ...16	301 ... 400	40 sec	60 sec
16.01 ...20	401 ... 500	50 sec	70 sec
20.01 ...25	501 ... 600	60 sec	80 sec

$$t_{roughen} [\text{sec}] = h_{ef} [\text{inch}] / 2,5$$

$$t_{roughen} [\text{sec}] = h_{ef} [\text{mm}] / 10$$





① US Rebar				① CA Rebar				② HIS-N, -RN							
d [inch]	HY 200-A V3		HY 200-R V3		d [mm]	HY 200-A V3		d [inch]	HIS-N		HIS-RN		h <sub>s</sub> [inch]	T <sub>inst</sub> [lb-ft]	d <sub>0</sub> [inch]
	h <sub>ef</sub> [inch]		h <sub>ef</sub> [inch]			h <sub>ef</sub> [mm]			h <sub>ef</sub> [inch]	h <sub>ef</sub> [inch]	d <sub>f</sub> [inch]				
#3	2 3/8 ... 22 1/2		3 3/8		10 M	70 ... 678		3/8	4 3/8	4 3/8	7/16	3/8 ... 15/16	≤15	1/2	
-	-		-			-			-		-		-		9/16
#4	2 3/4 ... 30		4 1/2		15 M	80 ... 960		1/2	5	5	9/16	1/2 ... 1 3/16	≤30	5/8	
#5	3 1/8 ... 37 1/2		5 5/8			90 ... 390			90 ... 1170		-		-		11/16
#6	3 1/2 ... 15		6 3/4		20 M	101 ... 504		5/8	6 3/4		11/16	5/8 ... 1 1/2	≤60	3/4	
#6	15 ... 45					101 ... 1512			13/16		13/16		3/4 ... 1 7/8		1 1/8
#7	3 1/2 ... 17 1/2				25 M	120 ... 598		3/4	8 1/8		1 1/2	1 1/2 ... 1 7/8	≤100	1	
#7	17 1/2 ... 52 1/2					120 ... 1794			1 1/2		1 1/2		1 1/2 ... 1 7/8		1 1/4
#8	4 ... 20				30 M	-		-	-		-	-	-	1 3/8	
#8	20 ... 60					-			-		-		-		1 1/2
#9	4 1/2 ... 22 1/2		4 1/2 ... 67 1/2		-		-		-		-		-	1 3/8	
#10	5 ... 25		5 ... 75		-		-		-		-		-	1 1/2	



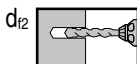
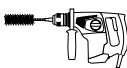

∅ d <sub>0</sub> [inch]	7/16	1/2	9/16	5/8	11/16	3/4	7/8	1	1 1/8	1 1/4	1 3/8	1 1/2
HIT-RB	7/16	1/2	9/16	5/8	11/16	3/4	7/8	1	1 1/8	1 1/4	1 3/8	1 1/2
HIT-SZ	-	1/2	9/16	5/8	11/16	3/4	7/8	1	1 1/8	1 1/4	1 3/8	1 1/2
HIT-DL	-	1/2	9/16	5/8	11/16	3/4	7/8	1	1	1	1 3/8	1 3/8
HIT-OHC	387551						387552					
TE-YRT	-	-	-	-	-	3/4	7/8	1	1 1/8	-	1 3/8	





HIT-DL: h<sub>ef</sub> > 10"

HIT-RB: h<sub>ef</sub> > 20d



③ HAS / HAS-E / HIT-V						④ HIT-Z, HIT-Z-R							
$d$ [inch]	 $h_{ef}$ [inch]	 $h_{ef}$ [inch]	$T_{inst}$ [lb-ft]	$d_{f1}$ [inch]	$d_{f2}$ [inch]	$d$ [inch]	 $h_{ef}$ [inch]	 $h_{ef}$ [inch]	$T_{inst}$ HIT-Z [lb-ft]	$T_{inst}$ HIT-Z-R [lb-ft]	$d_{f1}$ [inch]	$d_{f2}$ [inch]	$d_{b0}$ [inch]
3/8	2 3/8 ... 7 1/2	3 3/8	≤15	1/2	7/16	3/8	2 3/8 ... 4 1/2	3 3/8	15	30	1/2	7/16	7/16
1/2	2 3/4 ... 10	4 1/2	≤30	5/8	9/16	1/2	2 3/4 ... 6	4 1/2	30	65	5/8	9/16	9/16
5/8	3 1/8 ... 12 1/12	5 5/8	≤60	13/16*	11/16	5/8	3 3/4 ... 7 1/2	5 5/8	60	125	13/16*	11/16	3/4
3/4	3 1/2 ... 15	6 3/4	≤100	15/16	13/16	3/4	4 ... 8 1/2	6 3/4	110	165	15/16*	13/16	7/8
7/8	3 1/2 ... 17 1/2	6 3/4	≤125	1 1/8*	15/16								1
1	4 ... 20	-	≤150	1 1/4*	1 1/8								1 1/8
1 1/4	5 ... 25	-	≤200	1 1/2*	1 3/8								1 1/4
													1 1/2

HIT-RE-M			HIT-OHW
			
Art. No.			Art. No.
337111	HDM 330/500 HDE 500	VC 140/150/300	387550

			
$d_0$ [inch]	[inch]	Art. No. 381215	
7/16" ... 1 1/8"	2 3/8" ... 20"	✓	≥ 6 bar/90 psi @ 6 m³/h
1 1/4" ... 1 1/2"	4" ... 25"	-	≥ 140 m³/h / ≥ 82 CFM

① Rebar

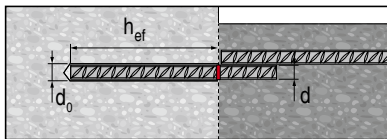

② HIS-N, -RN

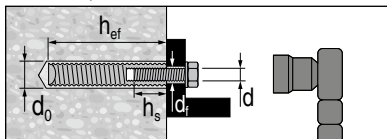

① Rebar		② HIS-N, -RN					③ HAS-U / HIT-V					ø d <sub>0</sub> [mm]
d [mm]	h <sub>ef</sub> [mm]	d [mm]	h <sub>ef</sub> [mm]	d <sub>f</sub> [mm]	h <sub>s</sub> [mm]	T <sub>inst</sub> [Nm]	d [mm]	h <sub>ef</sub> [mm]	T <sub>inst</sub> [Nm]	d <sub>f1</sub> [mm]	d <sub>f2</sub> [mm]	
<b>8</b>	60...480						<b>M8</b>	60-160	≤10	11	10	10
<b>10</b>	60...600	<b>M8</b>	90	9	8-20	≤10	<b>M10</b>	60-200	≤20	14	12	12
<b>12</b>	70...720						<b>M12</b>	70-240	≤40	16	14	14
<b>14</b>	75...1000	<b>M10</b>	110	12	10-25	≤20						16
<b>16</b>	80...1000						<b>M16</b>	80-320	≤80	20*	18	18
<b>18</b>	85...1000	<b>M12</b>	125	14	12-30	≤40	<b>M20</b>	90-400	≤150	24*	22	22
<b>20</b>	90...1000											25
<b>22</b>	95...1000	<b>M16</b>	170	18	16-40	≤80	<b>M24</b>	96-480	≤200	30*	26	28
							<b>M27</b>	108-540	≤270	32*	30	30
<b>24/25</b>	96/100...1000	<b>M20</b>	205	22	20-50	≤150						32
<b>26/28</b>	104/112...1000						<b>M30</b>	120-600	≤300	37*	33	35
<b>30</b>	120...1000											37
<b>32</b>	126...1000											40

## ③ HAS-U / HIT-V / HAS / HAS-E

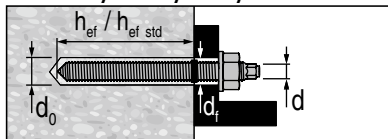

## ④ HIT-Z, -R

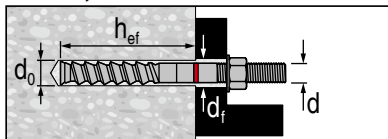

HIT-DL:  $h_{ef} > 250\text{mm}$     HIT-RB:  $h_{ef} > 20d$

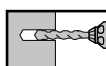
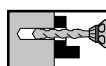

## ④ HIT-Z / HIT-Z-R

$d$ [mm]	$h_{nom}$ [mm]	$T_{inst}$ HIT-Z [Nm]	$T_{inst}$ HIT-Z-R [Nm]	$d_{f1}$ [mm]	$d_{f2}$ [mm]	$\varnothing d_0$ [mm]	HIT-RB	HIT-SZ	HIT-DL	HIT-OHC	TE-YRT	
<b>M8</b>	60-96	10	30	11	9	10	10			#387551		
<b>M10</b>	60-120	25	55	14	12	12	12	12				
<b>M12</b>	60-144	40	75	16	14	14	14	14	14			
<b>M16</b>	96-192	80	155	20*	18	18	18	18	18		18	
<b>M20</b>	100-220	150	215	24*	22	22	22	22	20	#387552	18	
						25	25	25	25		25	20
						28	28	28	25		28	22
						30	30	30	25		30	25
						32	32	32	32		32	30
						35	35	35	32	35	32	

 Rebar  $h_{ef} \geq 20d$



			$h_{ef}$		
HIT-HY 200-A HIT-HY 200-R V3	HDM, HDE	$\leq$ US #5	12 1/2 ... 37 1/2 [inch] 320 ... 960 [mm]	14°F...104°F -10°C...40°C	50°F...86°F 10°C...30°C
		$\leq$ EU 16mm	320 ... 960 [mm]		
		$\leq$ CAN 15M	320 ... 960 [mm]		
HIT-HY 200-A HIT-HY 200-R V3	HDE	$\leq$ US #5	12 1/2 ... 37 1/2 [inch] 320 ... 960 [mm]	14°F...104°F -10°C...40°C	32°F...86°F 0°C...30°C
		$\leq$ EU 16mm	320 ... 960 [mm]		
		$\leq$ CAN 15M	320 ... 960 [mm]		
HIT-HY 200-R V3	HDE	$\leq$ US #8	20 ... 60 [inch] 500 ... 1500 [mm]	32°F...104°F 0°C...40°C	32°F...86°F 0°C...30°C
		$\leq$ EU 25mm	504 ... 1512 [mm]		
		$\leq$ CAN 25M	504 ... 1512 [mm]		
HIT-HY 200-R V3	HDE	$\leq$ US #10	25 ... 75 [inch] 640 ... 1920 [mm]	50°F...86°F 10°C...30°C	50°F...68°F 10°C...20°C
		$\leq$ EU 32mm	598 ... 1794 [mm]		
		$\leq$ CAN 30M	598 ... 1794 [mm]		



			$h_{ef}$		
HIT-HY 200-A HIT-HY 200-R V3	HDM, HDE	$\leq$ US #5	12 1/2 ... 37 1/2 [inch] 320 ... 960 [mm]	14°F...104°F -10°C...40°C	50°F...86°F 10°C...30°C
		$\leq$ EU 16mm	320 ... 960 [mm]		
		$\leq$ CAN 15M	320 ... 960 [mm]		
HIT-HY 200-A HIT-HY 200-R V3	HDE	$\leq$ US #5	12 1/2 ... 37 1/2 [inch] 320 ... 960 [mm]	14°F...104°F -10°C...40°C	32°F...86°F 0°C...30°C
		$\leq$ EU 16mm	320 ... 960 [mm]		
		$\leq$ CAN 15M	320 ... 960 [mm]		
HIT-HY 200-R V3	HDE	$\leq$ US #8	20 ... 39 3/8 [inch] 500 ... 1000 [mm]	32°F...104°F 0°C...40°C	32°F...86°F 0°C...30°C
		$\leq$ EU 25mm	504 ... 1000 [mm]		
		$\leq$ CAN 25M	504 ... 1000 [mm]		

# 1



HIT-Z



$d_0$ : 7/16" ... 7/8"; 10 ... 22 mm  
 $h_{ef}$ : 2 3/8" ... 8 1/2"; 60 ... 220 mm

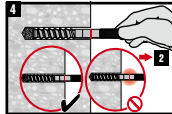
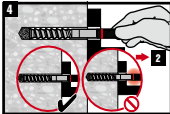
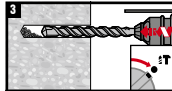
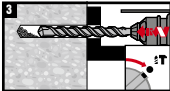
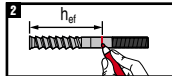
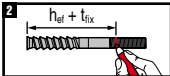
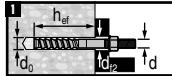
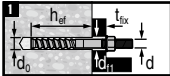
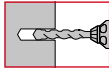
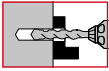

→ B

→ C

→ D

# 2

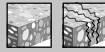

HIT-Z



$d_0$ : 7/16" ... 7/8"; 10 ... 22 mm  
 $h_{ef}$ : 2 3/8" ... 8 1/2"; 60 ... 220 mm

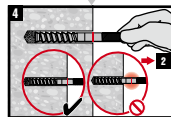
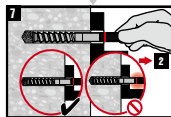
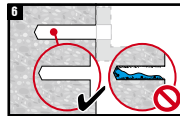
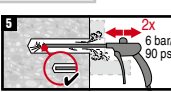
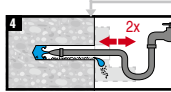
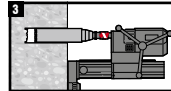
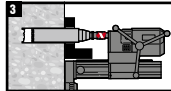
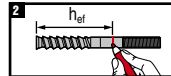
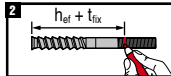
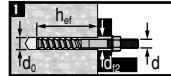
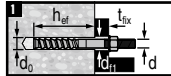
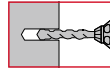
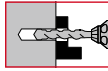

→ B

→ C

→ D

### 3

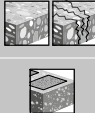
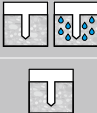

		HIT-Z HAS, HAS-E HAS-U, HIT-V HIS-N Rebar	
$d_o$ : 7/16" ... 1 3/8"; 10 ... 35 mm $h_{ef}$ : 2 3/8" ... 39 3/8"; 60 ... 1000 mm			

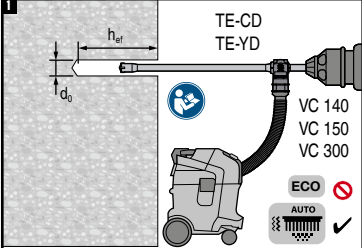



**1**





TE-CD  
TE-YD

VC 140  
VC 150  
VC 300

ECO   
 AUTO 

			
	2 3/8" ... 9 7/8" 60...250 mm	2 3/8" ... 75 1/2" 60...1000 mm	2 3/8" ... 75 1/2" 60...1000 mm
<p>→ <b>B</b>      → <b>C</b>      → <b>D</b></p>			

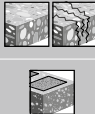
### 4

		HIT-Z HAS, HAS-E HAS-U, HIT-V HIS-N Rebar	
$d_o$ : 7/16" ... 1 1/2"; 10 ... 40 mm $h_{ef}$ : 2 3/8" ... 75 1/2"; 60 ... 1920 mm			

**1**

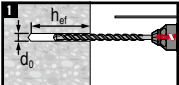

**2**

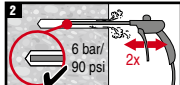

6 bar/  
90 psi

2x

**3**

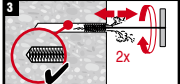

6 bar/  
90 psi





2x

**4**



6 bar/  
90 psi

2x

			
	2 3/8" ... 9 7/8" 60...250 mm	2 3/8" ... 75 1/2" 60...1920 mm	2 3/8" ... 75 1/2" 60...1920 mm
<p>→ <b>B</b>      → <b>C</b>      → <b>D</b></p>			

### 5

		HAS, HAS-E, HAS-U, HIT-V HIS-N Rebar	
$d_o$ : 3/4" ... 1 3/8"; 18 ... 35 mm $h_{ef}$ : 3 1/8" ... 25"; 80 ... 600 mm			

**1**



$d_o$      $h_{ef}$

**2**

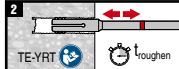

TE-YRT 

**3**

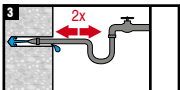

2x

**4**

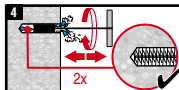

2x



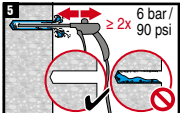

6 bar/  
90 psi

**5**



6 bar/  
90 psi

2x

			
	3 1/8" ... 10" 80...250 mm	3 1/8" ... 25" 80...600 mm	3 1/8" ... 25" 80...600 mm
<p>→ <b>B</b>      → <b>C</b>      → <b>D</b></p>			

# 6

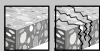

HAS, HAS-E,  
HAS-U, HIT-V  
Rebar



$d_r$ : 7/16" ... 1 3/8" ; 10 ... 40 mm  
 $h_{ef}$ : 2 3/8" ... 75" ; 60 ... 1920 mm

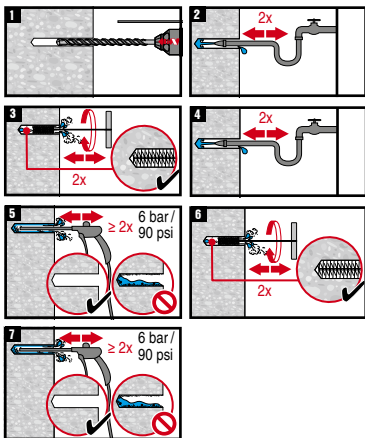

3 1/8" ... 10"  
80...250 mm



3 1/8" ... 25"  
80...600 mm

➔ **B**

➔ **C**

# A



$h_{ef}$ :  
2 3/8" ... 8 1/2"  
60 ... 220 mm

HIT-Z

HIT-RE-M

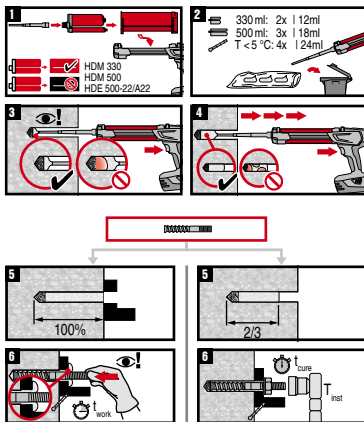

# B



$h_{ef}$ :  
2 3/8" ... 9 7/8"  
60 ... 250 mm

HIT-Z, HAS, HAS-E  
HAS-U, HIT-V  
HIS-N / Rebar

HIT-RE-M

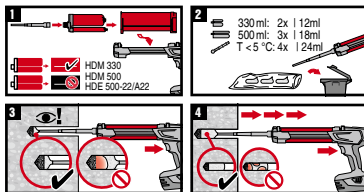

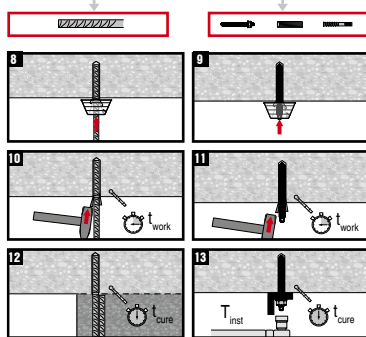
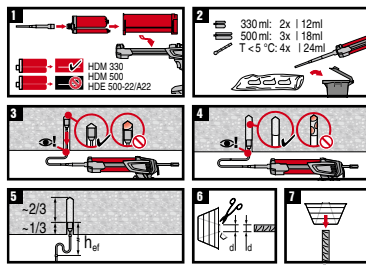
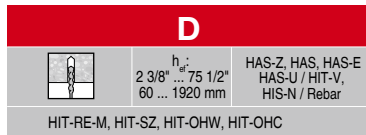
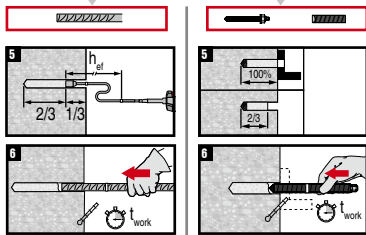
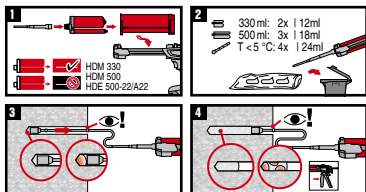
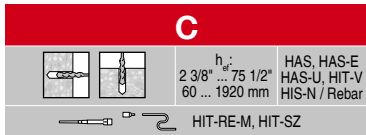
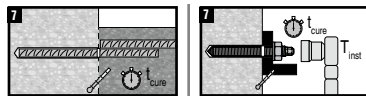
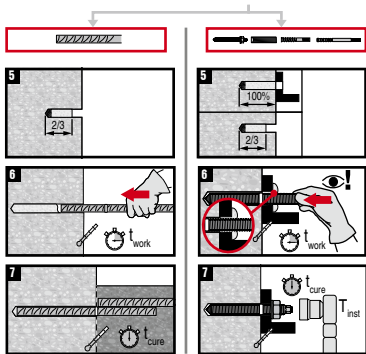

**EN** Adhesive anchoring system for rebar and anchor fastenings in concrete.**Hilti HIT-HY 200-A/-R V3**

**Contains:** hydroxypropylmethacrylate (A) 2,2'-(m-tolylimino) diethanol (A) 1,4-Butandiol-dimethacrylat (A) dibenzoyl peroxide (B)



(A, B)



(B)



**Warning** May cause an allergic skin reaction. (A, B) | Causes serious eye irritation. (B) | Very toxic to aquatic life with long lasting effects. (B) | Do not get in eyes, on skin or on clothing. | Wear eye protection, protective clothing, protective gloves. | **IF ON SKIN:** Wash with plenty of water. | **IF IN EYES:** Rinse cautiously with water for several minutes. Remove contact lenses, if present and easy to do. Continue rinsing. | If skin irritation or rash occurs: Get medical advice/attention. | If eye irritation persists: Get medical advice/attention.

**Disposal considerations:** **Empty packs:** Leave the mixer attached and dispose of via the local Green Dot recovery system or EAK waste material code: 150102 plastic packaging **Full or partially emptied packs:** Must be disposed of as special waste in accordance with official regulations. EAK waste material code: 08 04 09\* waste adhesives and sealants containing organic solvents or other dangerous substances. or EAK waste material code: 20 01 27\* paint, inks, adhesives and resins containing dangerous substances.

**Product Information:** Always keep these instructions together with the product even when given to other persons. **Material Safety Data Sheet:** Review the MSDS before use. **Check expiration date:** See imprint on foil pack manifold (month/year). Do not use expired product. **Foil pack temperature during usage:** 0 °C to 40 °C / 32 °F to 104 °F. **Base material temperature at time of installation:** **HAS-U, HIT-V, HIS, Rebar:** between -10 °C and 40 °C / 14 °F and 104 °F; **HIT-Z:** between +5°C and 40°C / 41°F and 104°F. **Conditions for transport and storage:** Keep in a cool, dry and dark place between 5 °C and 25 °C / 41 °F and 77 °F. For any application not covered by this document / beyond values specified, please contact Hilti. **Partly used foil packs must remain in the cassette** and has to be used within **4 weeks**. Leave the mixer attached on the foil pack manifold and **store within the cassette** under the recommended storage conditions. If reused, attach a new mixer and discard the initial quantity of anchor adhesive.

Failure to observe these installation instructions, use of non-Hilti anchors, poor or questionable concrete conditions, or unique applications may affect the reliability or performance of the fastenings.

**NOTICE**

- ▲ **The surface of the HIT-Z anchor rod must not be altered in any way.**
- ▲ **The thread of HIT-Z must stay free from dirt and dust during the installation procedure and its cones must be fully embedded into mortar (especially at minimum embedment). Torque moment must always be applied on HIT-Z nut and washer installed above a solid baseplate laying on concrete.**
- ▲ **Improper handling may cause mortar splashes.** Always wear safety glasses, gloves and protective clothes during installation. I Never start dispensing without a mixer properly screwed on. I Attach a new mixer prior to dispensing a new foil pack (ensure snug fit). I Use only the type of mixer (HIT-RE-M) supplied with the adhesive. Do not modify the mixer in any way. I Never use damaged foil packs and/or damaged or unclean foil pack holders (cassettes).
- ▲ **Poor load values / potential failure of fastening points due to inadequate borehole cleaning.** Hilti hollow drill bits TE-CD, TE-YD must be used in conjunction with a properly maintained Hilti vacuum cleaner with model and suction capacity (volumetric flow rate) as specified in the accessory table. I The boreholes must be free of debris, dust, water, ice, oil, grease and other contaminants prior to adhesive injection. I For blowing out the borehole – blow out with oil free air until return air stream is free of noticeable dust. I For flushing the borehole – flush with water line pressure until water runs clear. I For brushing the borehole – only use specified wire brush. The brush must resist insertion into the borehole – if not the brush is too small and must be replaced. I Important! Remove all water from the borehole and blow out with oil free compressed air until borehole is completely dried before mortar injection. I Do not exceed the roughening time when roughening the drilled hole!

- ▲ **Ensure that boreholes are filled from the back of the borehole without forming air voids.** If necessary use the accessories / extensions to reach the back of the borehole. | For overhead applications use the overhead accessories HIT-SZ and take special care when inserting the fastening element. Excess adhesive may be forced out of the borehole. Make sure that no mortar drips onto the installer. | In water saturated concrete it is required to set the anchor immediately after cleaning the borehole.
- ▲ **Not adhering to these setting instructions can result in failure of fastening points!**

## FR Mortier de scellement pour ancrage de chevilles et d'armatures dans le béton.

### Hilti HIT-HY 200-A/-R V3

**Contient:** hydroxypropylmethacrylate (A), Diméthacrylate de 1,4-butanediol (A) Diéthanol 2,2'-(m-tolylimino) (A), peroxyde de dibenzoyle (B)



(A, B)



(B)



**Attention** Peut provoquer une allergie cutanée. (A, B) | Provoque une sévère irritation des yeux. (B) | Très toxique pour les organismes aquatiques, entraîne des effets néfastes à long terme. (B) | Éviter tout contact avec les yeux, la peau ou les vêtements. | Porter un équipement de protection des yeux, des vêtements de protection, des gants de protection.. | **EN CAS DE CONTACT AVEC LA PEAU :** Laver abondamment à l'eau et au savon. | **EN CAS DE CONTACT AVEC LES YEUX :** Rincer avec précaution à l'eau pendant plusieurs minutes. Enlever les lentilles de contact si la victime en porte et si elles peuvent être facilement enlevées. Continuer à rincer. | En cas d'irritation ou d'éruption cutanée : consulter un médecin. | Si l'irritation oculaire persiste : consulter un médecin.

**Indications de recyclage Emballages vides:** Laisser la buse mélangeuse vissée et procéder à l'élimination par le biais du système de collecte national „Point Vert“. ou code déchets EAK : 150102 Emballages en plastique. **Emballages pleins ou à moitié vides:** Les apporter à un centre de collecte des matières dangereuses conformément aux dispositions administratives. Code déchets EAK : 08 04 09\* Résidus de colles et composants pour joints, contenant des solvants organiques ou d'autres substances dangereuses. ou code déchets EAK : 20 01 27\* Peintures, encres d'impression, colles et résines artificielles, contenant des substances dangereuses.

**Information produit** Le présent mode d'emploi doit toujours être conservé avec le produit, même s'il est confié à une autre personne. Avant toute utilisation, prendre connaissance de la **fiche de données de sécurité**. **Contrôler la date de péremption** (mois/année) imprimée sur le raccord de la cartouche. Ne plus utiliser le produit lorsque la date de péremption est dépassée **Température des cartouches souples en cours d'utilisation :** entre 0 °C et 40 °C / 32 °F et 104 °F. **Température du matériau support en cours d'utilisation :** **HAS-U, HIT-V, HIS, Rebar :** entre -10 °C et 40 °C / 14 °F et 104 °F. **HIT-Z :** entre +5 °C et 40 °C / 41 °F et 104 °F. **Conditions de transport et de stockage :** dans un endroit frais, sec et à l'abri de la lumière à une température de +5 °C à 25 °C / 41 °F à 77 °F. En cas d'applications qui ne sont pas décrites dans le présent mode d'emploi ou hors plage de valeurs spécifiées, s'adresser à Hilti. **Les cartouches souples entamées doivent rester dans le porte-cartouches** et être réutilisées dans les **quatre semaines**. Laisser la buse mélangeuse vissée et stocker la cartouche souple dans le **porte-cartouches** conformément à la réglementation. Avant réutilisation, visser une nouvelle buse mélangeuse et jeter le mortier extrudé lors des premières pressions.

Le non respect de ces instructions de pose, l'utilisation de chevilles autres qu'Hilti, la pose dans un béton faible ou matériau ou des applications particulières peuvent avoir un impact sur la sécurité et la performance de la fixation.

### ▲ AVIS

- ▲ **La surface de la tige d'ancrage HIT-Z ne doit pas être modifiée.**
- ▲ **Le filetage de la HIT-Z doit être propre et sans poussière lors de la pose et les cônes doivent être complètement ancrés dans la résine de scellement (en particulier à la profondeur minimale d'ancrage). Le couple de serrage doit toujours être appliqué sur l'écrou et la rondelle de la HIT-Z qui sont montés au-dessus de la platine posée sur le béton**
- ▲ **En cas de maniement non conforme, il y a risque de projection du mortier.** Lors du travail, porter une protection des yeux, des gants et des vêtements de protection! | Ne jamais commencer l'extrusion si la buse mélangeuse n'est pas vissée! | Avant de commencer l'extrusion d'une nouvelle cartouche souple, visser une nouvelle buse mélangeuse. Vérifier qu'elle est bien en

place. | Utiliser exclusivement le type de buse fourni avec le mortier (HIT-RE-M). Ne modifier la buse mélangeuse en aucun cas. | Ne jamais utiliser de cartouches souples endommagées ni de porte-cartouches endommagés ou très encrassés.

- ▲ Mauvaise fixation/défaillance du chevillage à cause d'un nettoyage insuffisant du trou.** Les mèches creuses Hilti TE-CD, TE-YD doivent être associées à un modèle d'aspirateur Hilti bien entretenu d'une capacité d'aspiration (débit volumétrique) conforme à la spécification du tableau des accessoires. | Avant de procéder à l'injection, s'assurer que le trou de perçage est exempt de débris de perçage, poussières, eau, glace, huile, graisse ou autres contaminants. | Soufflage du trou foré – avec de l'air exempt d'huile jusqu'à ce que l'air sortant soit exempt de toute poussière. | Rinçage du trou foré – rincer le trou à l'eau à pression de conduite normale jusqu'à ce que de l'eau propre ressorte. | Brossage du trou foré – uniquement avec un écouvillon en acier adapté. Une résistance doit se faire sentir lors de l'insertion de l'écouvillon dans le trou – si ce n'est pas le cas, l'écouvillon est trop petit et doit être remplacé. | Important ! Avant de remplir de mortier, évacuer l'eau du trou foré et le souffler avec de l'air comprimé exempt d'huile jusqu'à ce qu'il soit entièrement sec. | Lors du dégrossissage du trou de perçage, ne pas dépasser le temps de dégrossissage !
- ▲ Veiller à ce que le remplissage se fasse à partir du fond du trou pour éviter la formation de bulles d'air.** Si nécessaire, utiliser des prolongateurs pour atteindre le fond du trou. | En cas d'applications au plafond, utiliser l'accessoire HIT-SZ et faire particulièrement attention lors de l'introduction de l'élément de fixation. L'excédent de mortier peut ressortir du trou foré. Veiller alors à ce que celui-ci ne goutte pas sur l'opérateur. | Dans le béton saturé en eau, il s'avère nécessaire de poser la tige d'ancrage immédiatement après le nettoyage du trou percé !
- ▲ Le non-respect des instructions peut entraîner une défaillance du chevillage!**

## ES Resina de inyección para la fijación de anclajes y tacos en hormigón.

### Hilti HIT-HY 200-A/-R V3

**Contiene:** metacrilato de hidroxipropilo (A), Dimetacrilato de 1,4-butanodiol (A), 2,2'-(m-tolilmino)dietanol (A), peróxido de dibenzoilo (B)



(A, B)



(B)



**Atención | Puede provocar una reacción alérgica en la piel. (A, B) | Provoca irritación ocular grave. (B) | Muy tóxico para los organismos acuáticos, con efectos nocivos duraderos. (B) | Evitar el contacto con los ojos, la piel o la ropa. | Llevar gafas de protección, prendas de protección, guantes de protección. | EN CASO DE CONTACTO CON LA PIEL: lavar con agua y jabón abundantes. | EN CASO DE CONTACTO CON LOS OJOS: aclarar cuidadosamente con agua durante varios minutos. Quitar las lentes de contacto, si lleva y resulta fácil. Seguir aclarando. | En caso de irritación o erupción cutánea: consultar a un médico. | Si persiste la irritación ocular: consultar a un médico.**

**Indicaciones de reciclaje Cartuchos vacíos:** Deseche el mezclador enroscado a través del sistema de recogida nacional identificado como Punto Verde. O el código de residuo LER: 150102 embalajes de plástico **Cartuchos llenos o parcialmente vacíos:** Deberán eliminarse como residuos especiales de acuerdo con las normativas oficiales. Código de residuo LER: 08 04 09\* Residuos de adhesivos y sellantes que contienen disolventes orgánicos u otras sustancias peligrosas. O el código de residuo LER: 20 01 27\* Pinturas, tintas, adhesivos y resinas que contienen sustancias peligrosas.

**Información del producto** Conserve las presentes instrucciones de uso siempre junto con el producto y entréguelas también si el producto pasa a manos de otra persona. Consulte la **hoja de datos de seguridad** antes de utilizar el producto. **La fecha de caducidad** se indica en la pieza de conexión (mes/año). El producto no debe utilizarse después de la fecha de caducidad. **Temperatura del cartucho durante la utilización:** de 0 °C a 40 °C / de 32 °F a 104 °F. **Temperatura del material base durante la instalación:** Varilla HAS-U, Varilla HIT-V, manguito HIS, barra corrugada: de -10 °C a 40 °C / de 14 °F a 104 °F. **HIT-Z:** de +5 °C a 40 °C / de 41 °F a 104 °F. **Condiciones de transporte y almacenamiento:** lugar fresco, seco y oscuro con una temperatura de +5 °C a 25 °C / de 41 °F a 77 °F. Para aplicaciones que no se describen en las presentes instrucciones de uso o no se enmarcan en la especificación, póngase en contacto con Hilti. **Los cartuchos que no estén completamente vacíos deberán permanecer en el portacartuchos** y utilizarse antes de **cuatro semanas**. Para ello deberán guardarse en el portacartuchos con el mezclador enroscado en las condiciones de almacenamiento recomendadas. Antes de utilizarlo de nuevo, enroscar un nuevo mezclador y desechar la resina inicial.

La inobservancia de las instrucciones de instalación, el uso de anclajes que no sean Hilti, malas o dudosas condiciones del hormigón y/o aplicaciones inadecuadas pueden afectar la fiabilidad y respuesta de las fijaciones.

## **⚠ AVISO**

- ▲ **La superficie de la barra de anclaje HIT-Z no debe modificarse.**
- ▲ **La rosca de HIT-Z debe permanecer libre de suciedad y polvo durante la instalación y los conos deben estar completamente incrustados en la resina (especialmente en profundidad mínima). Tuerca y arandela de HIT-Z deben ser siempre ajustados con el torque correspondiente, fijando la placa base al concreto**
- ▲ **La resina puede salpicar si se utiliza incorrectamente.** Lleve gafas protectoras, guantes de protección y ropa de trabajo durante el trabajo. | No comience a inyectar si no se ha roscado el mezclador. | Enrosque un nuevo mezclador antes de trabajar con un cartucho nuevo. Asegúrese de que el mezclador está unido firmemente. | Utilice exclusivamente el modelo de mezclador (HIT-RE-M) suministrado con la resina. | No modifique el mezclador en ningún caso. No utilice cartuchos en mal estado y/o portacartuchos dañados o sucios.
- ▲ **Valores de sujeción deficientes/fallo de la fijación debido a limpieza insuficiente del taladro.** Las brocas huecas TE-CD, TE-YD de Hilti deben utilizarse con una aspiradora de Hilti en buen estado de funcionamiento del modelo y la capacidad de succión (tasa de flujo volumétrico) que se especifican en la tabla de accesorios. | Antes de inyectar la resina, los taladros deben estar libres de restos de perforación, polvo, agua, hielo, aceite, grasa o cualquier otro agente contaminante. | Soplado del taladro con aire sin aceite hasta que el aire que refluye esté libre de polvo. | Lavado del taladro: lave con una manguera de agua con la presión normal de la red hasta que salga agua limpia. | Limpieza del taladro: realícese sólo con un cepillo metálico de tamaño apropiado. Al cepillar el taladro, se notará cierta resistencia en el cepillo. Si no es este el caso, el cepillo es demasiado pequeño y debe cambiarse. | ¡Atención! Antes de añadir la resina es necesario extraer el agua del taladro y limpiar el taladro con aire a presión sin aceite hasta que quede completamente seco. | A la hora de raspar el taladro, no superar el tiempo de raspado.
- ▲ **Verificar que el relleno del taladro se produce desde el fondo del taladro para que no se formen burbujas de aire.** Si es necesario, utilice las prolongaciones para alcanzar el fondo del taladro. | En aplicaciones por encima de la cabeza, utilice el accesorio HIT-SZ y preste especial atención al introducir el elemento de fijación. Puede salir resina sobrante del taladro. Asegúrese de que la resina no gotee sobre el usuario. | En el hormigón saturado de agua es necesario colocar el anclaje inmediatamente después de limpiar el taladro.
- ▲ **El incumplimiento de estas instrucciones puede llevar a una fijación incorrecta.**

## **PT** Buchas químicas para fixações de ferros e de ancoragens em betão.

### Hilti HIT-HY 200-A/-R V3

**Contains:** metacrilato de hidroxipropilo (A), Dimetacrilato de 1,4-butanodiol (A), 2,2 - (m-tolilimino) dietanol (A), peróxido de dibenzoilo (B)



(A, B)



(B)



**Atenção** Pode provocar uma reacção alérgica cutânea. (A, B) | Provoca irritação ocular grave.(A) | Muito tóxico para os organismos aquáticos com efeitos duradouros. (B) | Usar proteção ocular, vestuário de proteção, luvas de proteção.. | Não pode entrar em contacto com os olhos,a pele ou a roupa. | **SE ENTRAR EM CONTACTO COM OS OLHOS:** enxaguar cuidadosamente com água durante vários minutos. | **SE ENTRAR EM CONTACTO COM OS OLHOS:** enxaguar cuidadosamente com água durante vários minutos. Se usar lentes de contacto, retire-as, se tal lhe for possível. Continuar a enxaguar. | Em caso de irritação ou erupção cutânea: consulte um médico. | Caso a irritação ocular persista: consulte um médico.

**Recomendação sobre a eliminação** Cartuchos vazios: Deixar o misturador enroscado e eliminar através do sistema de recolha „Ponto Verde” nacional. ou código CER: 150102 Embalagens de plástico **Cartuchos semiusados ou novos:** Eliminar de acordo com as normas e regulamentações legais sobre resíduos especiais. Código CER: 08 04 09\* Resíduos de colas ou vedantes,

contendo solventes orgânicos ou outras substâncias perigosas. ou código CER: 20 01 27\* Tintas, produtos adesivos, colas e resinas, contendo substâncias perigosas.

**Dados informativos sobre o produto** Guarde estas instruções de utilização sempre junto com o produto, mesmo quando o entregar a outras pessoas. Antes de iniciar os trabalhos, tenha em consideração a **ficha técnica de segurança**. Veja o **prazo de validade** (mês/ano) na peça de junção. Não utilize produtos cujo prazo de validade se encontre ultrapassado. **Temperatura do cartucho durante a utilização:** entre 0 °C e 40 °C / 32 °F e 104 °F. **Temperatura do material base durante a instalação:** **HAS-U, HIT-V, HIS, Rebar:** entre -10 °C e 40 °C / 14 °F e 104 °F. **HIT-Z:** entre +5 °C e 40 °C / 41 °F e 104 °F. **Condições de transporte e armazenamento:** em lugar fresco, seco e ao abrigo da luz, entre +5 °C e 25 °C / 41 °F e 77 °F. Em caso de aplicações que não se encontrem descritas nas presentes instruções de utilização ou estejam fora das especificações, é favor dirigir-se à Hilti. **As sobras de cartuchos parcialmente usados devem permanecer** no suporte e ser utilizadas num prazo de **quatro semanas**. Deixe o misturador enroscado e armazene-o **no suporte** juntamente com o cartucho, de acordo com as condições de armazenagem preconizadas. Quando/se reutilizados, utilize um misturador novo e não utilize novamente a resina inicial.

O não cumprimento destas instruções de colocação, a utilização de ancoragens que não sejam da Hilti, as condições fracas ou duvidosas do betão, ou aplicações fora do comum podem afectar a segurança ou a eficácia das fixações.

### **⚠ AVISO**

- ⚠ **A superfície do varão roscado HIT-Z não pode ser modificada.**
- ⚠ **A rosca do varão HIT-Z deve estar livre de sujidade ou poeira durante o processo de instalação e as suas extremidades devem estar totalmente imbuídas de ancoragem química (especialmente o embhecimento mínimo). O momento de torque deve ser sempre aplicado na porca do HIT-Z e a anilha instalada sobre a placa de base de ancoragem sobre o betão.**
- ⚠ **No caso de manuseamento incorrecto, é possível que seja injectada resina.** Durante a realização de trabalhos, use óculos de protecção, luvas de protecção e roupa de trabalho! Nunca comece a aplicação sem que o misturador esteja enroscado! | Antes da aplicação de um novo cartucho, enrosque um misturador novo. Certifique-se de que está bem apertado. | Utilizar apenas o tipo de misturador (HIT-RE-M) fornecido com a resina. Não modifique o misturador de forma alguma. | Nunca utilize cartuchos danificados e/ou suportes danificados ou sujos.
- ⚠ **Valores de retenção deficientes/falha da fixação devido a limpeza insuficiente do furo.** A brocas de perfuração ocas Hilti TE-CD e TE-YD têm de ser usadas em conjunto com um aspirador Hilti em boas condições de funcionamento e com o modelo e capacidade de aspiração (débito volumétrico) especificados na tabela dos acessórios. | Antes da injeção, os furos têm de estar isentos de material de perfuração, pó, água, gelo, óleo, gordura ou outras impurezas. | Limpar o furo por sopro com ar isento de óleo, até que o ar saia sem pó. | Lavar o furo – com uma mangueira com pressão normal, até sair água limpa. | Escovar o furo – apenas com uma escova de aço adequada. Ao escovar o furo deverá ser perceptível uma resistência na escova – se não for o caso, a escova é demasiado pequena e deverá ser substituída. | Importante! Antes de preencher com resina, retire a água do furo e sopra com ar isento de óleo até estar totalmente seco. | Ao tornar a furação áspera, não ultrapassar o tempo de rugosidade!
- ⚠ **Assegure que o enchimento do furo é efectuado a partir do fundo, para que não se formem bolhas de ar.** Se necessário, utilize os prolongadores para alcançar o fundo do furo. | No caso de aplicações em suspensão, utilize o acessório HIT-SZ e preste especial atenção ao inserir o elemento de fixação. Pode sair resina em excesso do furo. Certifique-se de que não pinga resina sobre o utilizador. | Em betão saturado de água, é necessário colocar a âncora imediatamente após a limpeza do furo!
- ⚠ **A não observação das instruções pode conduzir à falha da fixação!**





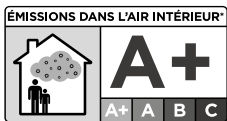

\* Information sur le niveau d'émission de substances volatiles dans l'air intérieur, présentant un risque de toxicité par inhalation, sur une échelle de classe allant de A+ (très faibles émissions) à C (fortes émissions).



Certified to  
NSF/ANSI/CAN 61

Made in Germany

Hilti = registered trademark of  
Hilti Corporation, Schaan, Liechtenstein  
[www.hilti.group](http://www.hilti.group)

© 2022 Right of technical changes reserved S.E. & O



2334935 V4-07.2022