

# Hollyland Solidcom C1

Quick Guide

V1.0.1

# INTRODUCTION

Thank you for purchasing Hollyland Full-duplex Wireless Intercom System.

The Solidcom C1 full-duple wireless intercom headset system, adopting the advanced DECT 6.0 technology, is Hollyland's first true wireless and self-contained headset communication solution with exceptional sound clarity.

The system operates in the 1.9GHz band, providing a reliable transmission range up to 1000ft (350m) radius (LOS).

This Quick Guide will guide you through the installation and use of the equipment.

# PACKING LIST

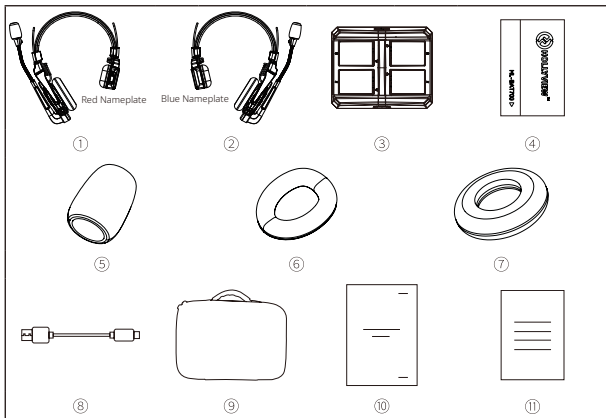

## Solidcom C1 -2S 2-person Headset Intercom Package

①	Master Headset (with red nameplate)	x1
②	Remote Headset (with blue nameplate)	x1
③	Charging Case	x1
④	Battery	x4
⑤	Microphone Cushion	x2
⑥	Over-ear Leather Cushion	x2
⑦	On-ear Foam Cushion	x2
⑧	USB Type-A to Type-C Cable	x1
⑨	Storage Case	x1
⑩	Quick Guide	x1
⑪	WarrantyCard	x1

Note: The amount of the items listed above depends on the edition.

Using a non-Hollyland or incompatible battery may increase the risk of fire or explosion. Replace the battery only with a compatible battery purchased from Hollyland or authorized dealers that is designed to work with your Solidcom C1 headsets. Please dispose of damaged batteries under guidance.

# PACKING LIST

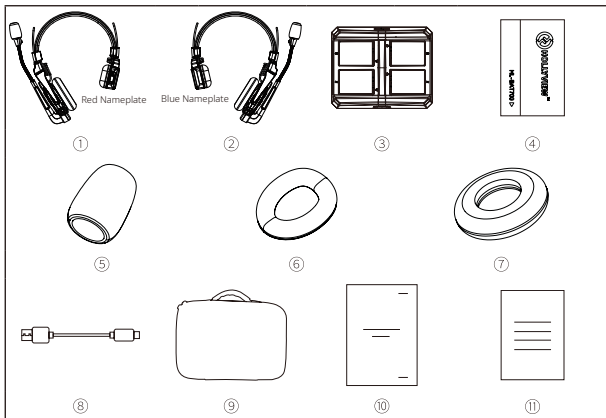

## Solidcom C1 -3S 3-person Headset Intercom Package

① Master Headset (with red nameplate)	x1
② Remote Headset (with blue nameplate)	x2
③ Charging Case	x1
④ Battery	x6
⑤ Microphone Cushion	x3
⑥ Over-ear Leather Cushion	x3
⑦ On-ear Foam Cushion	x3
⑧ USB Type-A to Type-C Cable	x1
⑨ Storage Case	x1
⑩ Quick Guide	x1
⑪ WarrantyCard	x1

Note: The amount of the items listed above depends on the edition.

Using a non-Hollyland or incompatible battery may increase the risk of fire or explosion. Replace the battery only with a compatible battery purchased from Hollyland or authorized dealers that is designed to work with your Solidcom C1 headsets. Please dispose of damaged batteries under guidance.

# PACKING LIST

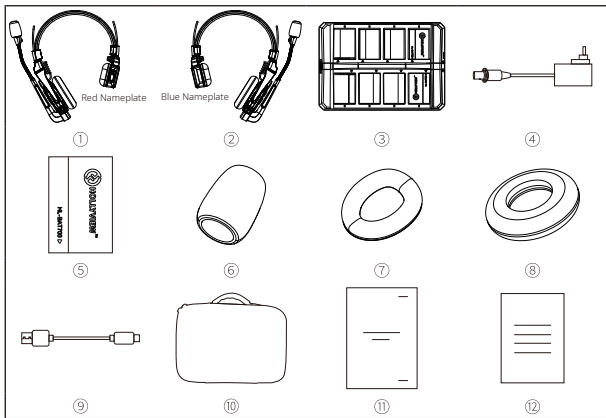

## Solidcom C1 - 4S 4-person Headset Intercom Package

① Master Headset (with red nameplate)	x1
② Remote Headset (with blue nameplate)	x3
③ Charging Case	x1
④ DC Adapter	x1
⑤ Battery	x8
⑥ Microphone Cushion	x4
⑦ Over-ear Leather Cushion	x4
⑧ On-ear Foam Cushion	x4
⑨ USB Type-A to Type-C Cable	x1
⑩ Storage Case	x1
⑪ Quick Guide	x1
⑫ Warranty Card	x1

Note: The amount of the items listed above depends on the edition.  
Using a non-Hollyland or incompatible battery may increase the risk of fire or explosion. Replace the battery only with a compatible battery purchased from Hollyland or authorized dealers that is designed to work with your Solidcom C1 headsets. Please dispose of damaged batteries under guidance.

# PACKING LIST

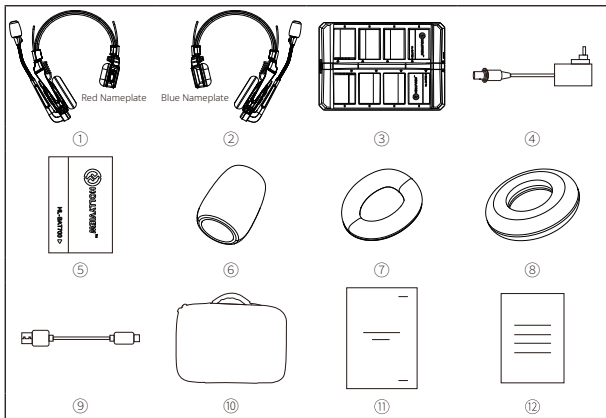

## Solidcom C1 - 6S 6-person Headset Intercom Package

① Master Headset (with red nameplate)	x1
② Remote Headset (with blue nameplate)	x5
③ Charging Case	x1
④ DC Adapter	x1
⑤ Battery	x12
⑥ Microphone Cushion	x6
⑦ Over-ear Leather Cushion	x6
⑧ On-ear Foam Cushion	x6
⑨ USB Type-A to Type-C Cable	x1
⑩ Storage Case	x1
⑪ Quick Guide	x1
⑫ Warranty Card	x1

Note: The amount of the items listed above depends on the edition.

Using a non-Hollyland or incompatible battery may increase the risk of fire or explosion. Replace the battery only with a compatible battery purchased from Hollyland or authorized dealers that is designed to work with your Solidcom C1 headsets. Please dispose of damaged batteries under guidance.

# PACKING LIST

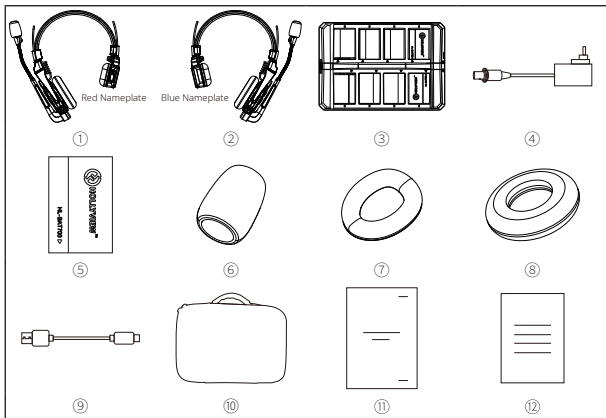

## Solidcom C1 - 8S 8-person Headset Intercom Package

① Master Headset (with red nameplate)	x1
② Remote Headset (with blue nameplate)	x7
③ Charging Case	x1
④ DC Adapter	x1
⑤ Battery	x16
⑥ Microphone Cushion	x8
⑦ Over-ear Leather Cushion	x8
⑧ On-ear Foam Cushion	x8
⑨ USB Type-A to Type-C Cable	x1
⑩ Storage Case	x1
⑪ Quick Guide	x1
⑫ Warranty Card	x1

Note: The amount of the items listed above depends on the edition.

Using a non-Hollyland or incompatible battery may increase the risk of fire or explosion. Replace the battery only with a compatible battery purchased from Hollyland or authorized dealers that is designed to work with your Solidcom C1 headsets. Please dispose of damaged batteries under guidance.

## PRODUCT INTERFACES

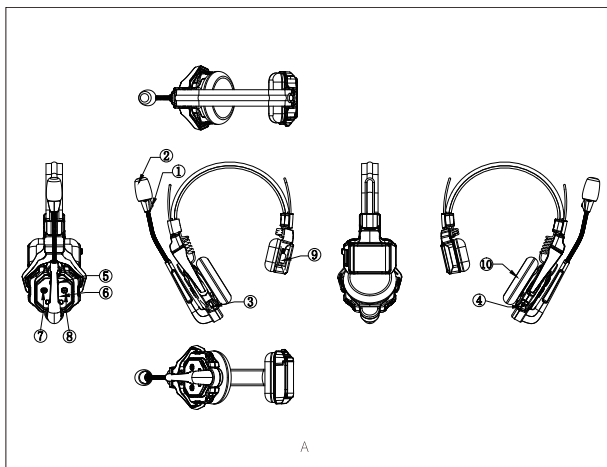

### A Headset Interface

- ① Power/Connection Indicator
- ② Microphone - Mute/unmute microphone by moving microphone boom up/down
- ③ USB Type-C Interface - for firmware upgrade
- ④ Power Toggle
- ⑤ Volume + Button
- ⑥ Volume - Button
- ⑦ A Button - Long press for 5 seconds to pair
- ⑧ B Button - Only functions when using with the HUB station
- ⑨ Battery Compartment
- ⑩ Speaker

## PRODUCT INTERFACES

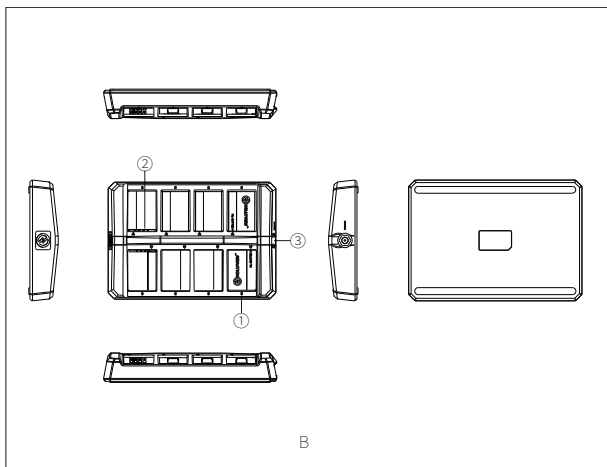

### **B** Charging Case Interface

- ① Charging Indicator      Orange: Charging in progress      Green: Fully charged  
② Charging Contacts  
③ DC Charging Interface

# QUICK GUIDE

## ① Install the battery.

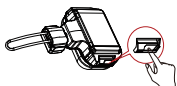

Step1: Slide the battery compartment cover lock

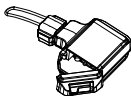

Step2: Open the cover

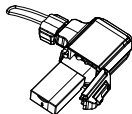

Step3: Place the battery into the compartment and close the battery cover

## ② Turn on the Master Headset and Remote Headsets.

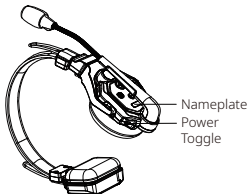

Master Headset in Operation

1. Ensure the headsets are all turned on when using Solidcom C1 full-duplex wireless intercom system.
2. The indicator lights stop flashing and turn to static green when the Master Headset is paired with the Remote Headsets.
3. The Master Headset is fitted with a red nameplate while the Remote Headset is fitted with a blue one.

## ③ Turn on microphone.

Range within which the Microphone is in Mute

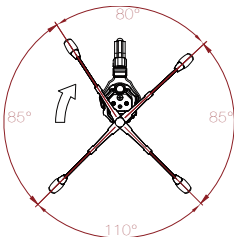

Microphone mute range when moving the microphone boom upward clockwise

Range within which the Microphone is in Mute

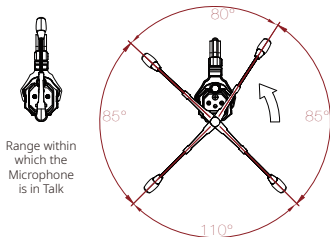

Microphone mute range when moving the microphone boom downward anti-clockwise

## ④ The Solidcom C1 system is now ready for use.

## Microphone Status Indicator

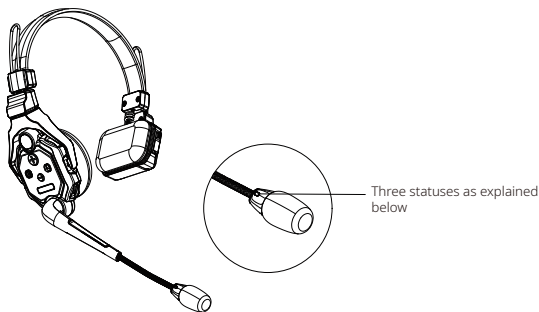

- 1. Indicator Light Flashes Green:** Disconnected (for Remote Headsets)
- 2. Indicator Light Stays Green:** Remote Headset(s) connection successful (by default, the Master Headset's indicator light will light up when turned on)
- 3. Indicator Light Flashes Red:** Low battery level

### Pairing

All Remote Headsets and the Master Headset come in one package will auto pair up right out of box. Manual pairing is only required when there is a need for adding new headset to the system. During the pairing process, please turn on all the headsets to ensure all the Remote Headsets are connected.

1. Long press the A Buttons on the Master Headset and Remote Headsets for 5 seconds, the indicator lights on the headsets' microphone booms will flash green. Please wait for the device to complete the pairing.
2. The indicator lights on the headsets' microphone booms become static green when pairing succeeds.
3. One Master Headset can be paired with 7 Remote Headsets in maximum.

Solidcom C1 is extremely versatile and can be applied in a variety of scenarios. For more information of how to operate this system, please check out on: <https://hollyland-techhelp.zendesk.com/hc/en-us/categories/360005064994-Download>

# PARAMETERS

Transmission Range	350m (1000ft) Line-of-Sight
Frequency Information	Frequency band: 1.9GHz DECT (varies by country and region) Modulation mode: GFSK Transmit power: <21dBm (125.9mW) (varies by country and region) Receiving sensitivity: <-90dBm
Transmission Latency	<35ms
Battery Capacity	700mAh (2.66Wh) Li-Ion battery
Runtime	Remote headset: $\approx$ 10h Master headset: $\approx$ 6h (when connected with 3 Remote headsets) Master headset: $\approx$ 5h (when connected with 5 Remote headsets) Master headset: $\approx$ 4h (when connected with 7 Remote headsets)
Charging Time	$\approx$ 2.5h
Frequency Response	150Hz – 7kHz
Signal-to-Noise Ratio	>55dB
Distortion	<1%
Microphone Type	Electret
Maximum Input Sound Pressure Level	>115dBSPL
Output Sound Pressure Level	98 $\pm$ 3dBSPL (at 94dBSPL 1kHz )
Net Weight	$\approx$ 170g (batteries included)
Working Temperature	0~+45°C (Working Status) -20~+60°C (Storage Status)

Note: The frequency band and transmit power varies by country and region.

## **SAFETY PRECAUTIONS**

Do not place the headsets near or inside heating devices (including but not limited to microwave ovens, induction cookers, electric ovens, electric heaters, pressure cookers, water heaters, gas stoves) to prevent the battery from overheating and exploding.

Never use non-original charging cases, cables and batteries with the product. The use of non-original spare parts may cause electric shock, fire, explosion or other dangers.

# SUPPORT

**If encounter any problems in using the product or need any help, please follow these ways to get more technical support:**

-  Hollyland User Group
-  HollylandTech
-  HollylandTech
-  HollylandTech
-  [support@hollyland-tech.com](mailto:support@hollyland-tech.com)
-  [www.hollyland-tech.com](http://www.hollyland-tech.com)

**Statement:**

All copyrights belong to Shenzhen Hollyland Technology Co., LTD.

**Trademark Statement:**

Without the written approval of Shenzhen Hollyland Technology Co., LTD, no organization or individual may copy or reproduce part or all of the content of the text without authorization, and may not disseminate it in any form.

All representations, information, recommendations in this document do not constitute warranties of any kind, express or implied.

**Note:**

Due to product version upgrades or other reasons, this quick guide will be updated from time to time. Unless otherwise agreed, this document is provided as a guide for use only. All representations, information, recommendations in this document do not constitute warranties of any kind, express or implied.

## **FCC Requirement**

Any changes or modifications not expressly approved by the party responsible for compliance could void the user's authority to operate the equipment. This device complies with Part 15 of the FCC Rules. Operation is subject to the following two conditions:

- (1) this device may not cause harmful interference.
- (2) this device must accept any interference received, including interference that may cause undesired operation.

FCC Radiation Exposure Statement:

The device has been tested and comply with FCC SAR limits.

**Note:** This equipment has been tested and found to comply with the limits for a Class B digital device, pursuant to Part 15 of the FCC Rules. These limits are designed to provide reasonable protection against harmful interference in a residential installation. This equipment generates, uses, and can radiate radio frequency energy, and if not installed and used in accordance with the instructions, may cause harmful interference to radio communications. However, there is no guarantee that interference will not occur in a particular installation. If this equipment does cause harmful interference to radio or television reception, which can be determined by turning the equipment off and on, the user is encouraged to try to correct the interference by one or more of the following measures:

- Reorient or relocate the receiving antenna.
- Increase the separation between the equipment and receiver.
- Connect the equipment into an outlet on a circuit different from that to which the receiver is connected.
- Consult the dealer or an experienced radio/TV technician for help.