



# SYSCOM 1000T

## User Manual

V1.1.0

For the latest and detailed user guide, please download it from the official website:  
[www.hollyland-tech.com/support/Download](http://www.hollyland-tech.com/support/Download)





**HOLLYVIEW**  
Powered by Hollyland



## DESCRIPTION

Thank you for purchasing Hollyland SYSCOM 1000T full-duplex wireless intercom system. With the DECT protocol technology, SYSCOM 1000T is widely used in the areas of studio, stage events, EFP, webcasting, filmmaking and etc. The transmission range of SYSCOM 1000T reaches up to 1000ft in a clean line of sight (LOS) with full-duplex wireless communication and carrier-grade voice quality.

### KEY FEATURES

- 1000ft Communication Range, Carrier-Grade Voice Quality
- 1.9GHz Frequency Bandwidth
- Full-Duplex Wireless Communication
- Up to 8 Beltpacks Communication Simultaneously (Base Station)
- Support Gooseneck Microphone, Speaker Call, 3.5mm Headset and 4-Pin Analog Audio Connection (Base Station)
- Support External Connection with Other Intercom Systems
- Base Station and Beltpacks Support PC Software Upgrade
- Support Wireless TALLY
- Built-In Lithium Batteries, with Longer than 8 Hours Run Time on a Full Charge (Beltpacks)
- Industrial Metal Case, Stable and Reliable

### APPLICATIONS

- Filmmaking
- Live Broadcasting
- Corporate Events
- Production Crew Communication
- Stage Activities
- Emergency Dispatch
- Webcasting
- TV Station

# PACKING LIST

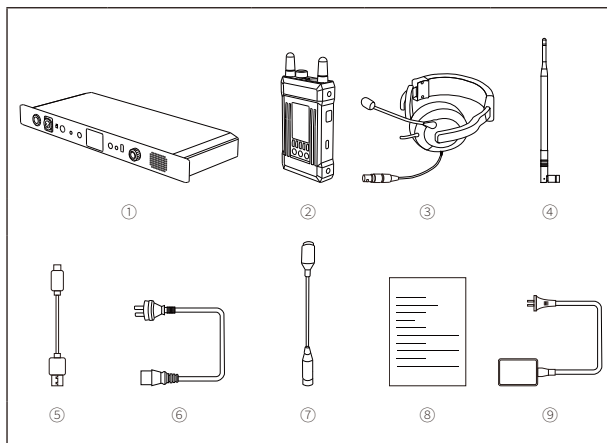

## SINGLE RECEIVER PACKING

① Base Station	x1
② Beltpack	x8
③ Professional Dynamic LEMO Single-Ear Headset	x9
④ 1.9G High-Gain Base Station Antenna	x6
⑤ USB Type-C Cable	x8
⑥ AC Power Cable	x1
⑦ 3-Pin XLR Gooseneck Microphone	x1
⑧ User Manual	x1
⑨ Multi-Port USB Charger	x2

\* The number of accessories is related to the configuration. The actual accessories number might be different in each case.

# PACKING LIST

## OPTIONAL ACCESSORIES NOT INCLUDED IN THE STANDARD PACKING LIST

<b>Headset</b>	Professional Electret Single-Ear Headset Single-Ear Mobile Earphone Air Duct Earphone Over-Ear Headphones
<b>TALLY</b>	Tally Cable Adapt to Different Switcher External BI-Color Tally Lights and Extension Cable
<b>Antenna</b>	1.9G Dual-Polarized High-Gain Panel Antenna
<b>Power Adaptor</b>	D-TAP to 4-Pin XLR DC Cable
<b>Gooseneck Microphone</b>	Dynamic Gooseneck Microphone
<b>Installation Tool</b>	Beltpack Cold Shoe
<b>Cascade Accessories</b>	4-Wire to 2-Wire Converter Ethernet to XLR Cable

# STANDARD SETUP

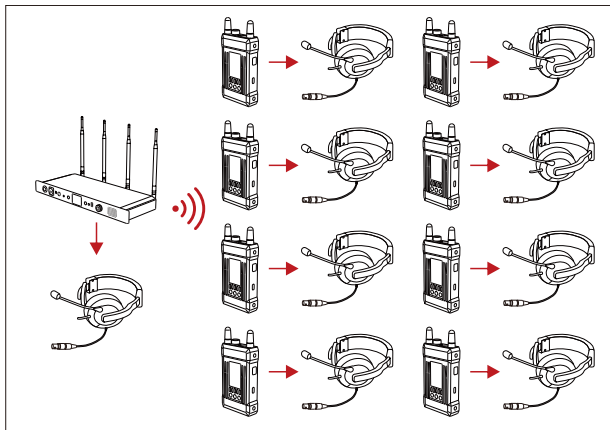

## TYPICAL SETUP USING THIRD PARTY EQUIPMENT

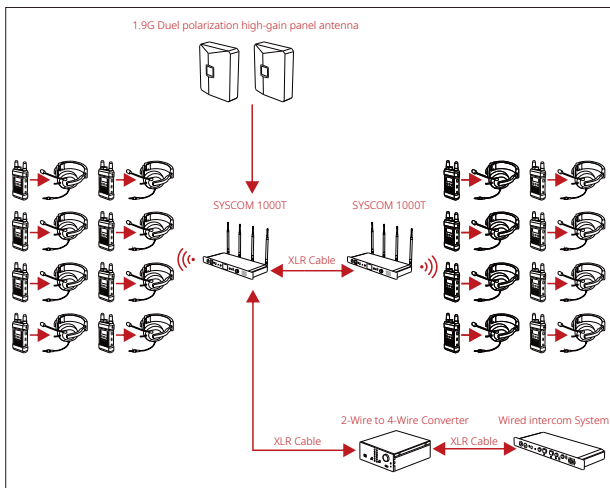

SYSCOM 1000T with standard 4-wire audio interface, which can connection with different type of intercom system to increase the quantity of beltpacks and also the wireless communication range. And if the live environment is complex, you can enhance the anti-interference by change the standard antennas to panel antennas.

# PRODUCT INTERFACES

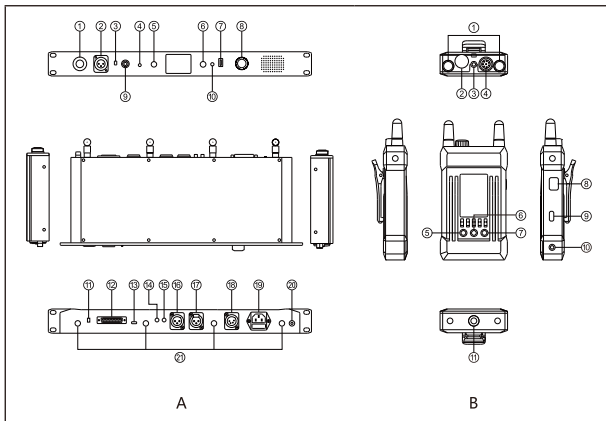

## A BASE STATION

- ① DC Power Supply
- ② Gooseneck Microphone (3-pin XLR male)
- ③ Dynamic and Electronic Gooseneck Microphone Switch Button
- ④ 3.5mm Headphone Interface (US)
- ⑤ Base Station MIC MUTE Button
- ⑥ Beltpack MIC MUTE Button
- ⑦ USB Type-A Interface (for cable connection between the base station and belt pack for belt pack registration and charging)
- ⑧ Volume Control Knob
- ⑨ LEMO Headset Interface
- ⑩ Reserved Button
- ⑪ Dial Switch (TALLY mode selection)
- ⑫ TALLY Control Interface
- ⑬ USB Type-C Debugging Interface
- ⑭ Audio Input Control Knob
- ⑮ Audio Output Control Knob
- ⑯ Analog Audio Output Interface (3-pin XLR male)

# PRODUCT INTERFACES

## A BASE STATION

- ⑰ Analog Audio Input Interface (3-pin XLR female)
- ⑱ DC Adaptor (4-pin XLR male)
- ⑲ AC Adaptor
- ⑳ Ground Pole
- ㉑ RF Antenna Interface

## B BELTPACK

- ① Antenna
- ② Power and Volume Control Knob
- ③ 3.5mm Headphone Interface
- ④ LEMO Headset Interface
- ⑤ Up/Left Button
- ⑥ Menu/Confirm Button (long press to enter the menu /click to confirm)
- ⑦ Down/Right Button
- ⑧ Mute/Talk Switch Button (double click to mute/long press to talk)
- ⑨ Type-C USB Interface (for cable connection between the base station and beltpack for belt pack registration and charging)
- ⑩ 3-Segment 3.5mm TALLY Output Interface
- ⑪ 1/4 Screw Hole

# PRODUCT INTERFACES

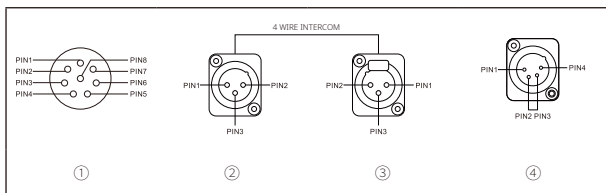

## ① LEMO HEADSET INTERFACES

PIN1: GND  
PIN2: GND  
PIN3: SPK  
PIN4: SPK  
PIN5: MIC  
PIN6: MIC  
PIN7: NULL  
PIN8: NULL

## ② AUDIO OUT INTERFACE

PIN1: GND  
PIN2: AUDIO OUT +  
PIN3: AUDIO OUT -

## ③ AUDIO IN INTERFACE

PIN1: GND  
PIN2: AUDIO IN +  
PIN3: AUDIO IN -

## ④ DC POWER SUPPLY

PIN1: GND  
PIN2: NULL  
PIN3: NULL  
PIN4: POWER

# PRODUCT DISPLAY INTRODUCTION

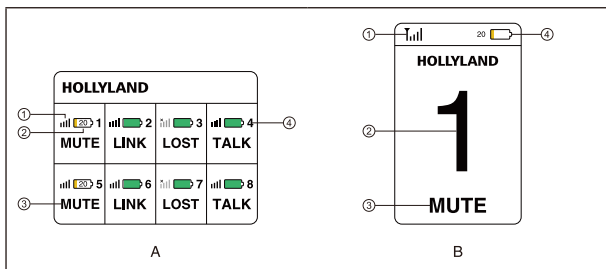

## A BASE STATION

- ① Beltpack Signal Strength
- ② Beltpack Real-Time Battery Status (actual percentage will be displayed when the battery is lower than 20%)
- ③ Beltpack Current Status
- ④ Beltpack Number

## B BELTPACK

- ① Beltpack Signal Strength
- ② Beltpack Number
- ③ Beltpack Current Status
- ④ Beltpack Real-Time Battery Status

# BELTPACK MENU FUNCTION INTRODUCTION

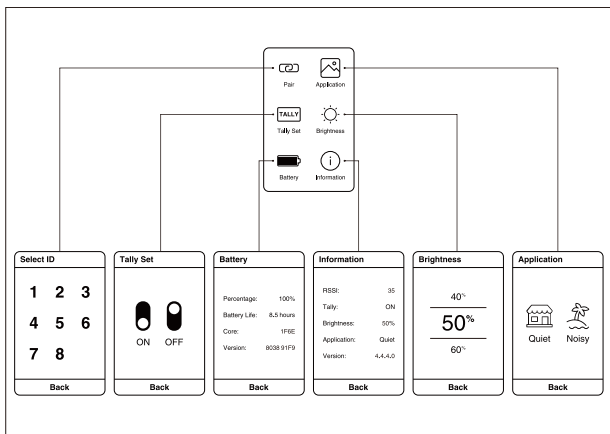

Long press the "OK" button for about three seconds to enter the root menu, select the menu and press "OK" to enter the next level. Each menu feature is described as follows,

## **1** Select "Pair" and press "OK" to enter the secondary menu of the registration feature

- 1.1. Select any ID from 1 to 8 then press "OK" to register the beltpack. "Pairing..." will be displayed on the main interface of the beltpack and the base station. Unplug the USB cable after "Pairing Successful" is displayed on the screen of both of them

## **2** Select "Application" and press "OK" to enter the secondary menu of scene mode configuration

- 2.1. Select "Quiet" and press "OK" when in a quiet environment
- 2.2. Select "Noisy" and press "OK" when in a noisy environment

# BELTPACK MENU FUNCTION INTRODUCTION

## **3 Select "Tally Set" and press "OK" to enter the secondary menu of LCD Screen TALLY Display setup**

- 3.1. Select "OFF" and press "OK" to turn off TALLY display
- 3.2. Select "ON" and press "OK" to turn on TALLY display

## **4 Select "Brightness" and press "OK" to enter the secondary menu of Screen brightness adjustment**

- 4.1. Press "Up" and "Down" to select current appropriate brightness press "OK" to finish the setup

## **5 Select "Battery" and press "OK" to enter the secondary menu of the battery information interface**

- 5.1. "Percentage" displays the current power percentage
- 5.2. "Battery Life" displays current working status, battery remaining time
- 5.3. "Core" displays the current battery cell core version
- 5.4. "Version" displays the current firmware version

## **6 Select "Information" and press "OK" to enter the secondary menu of system information inquiry**

- 6.1. "RSSI" displays the current wireless signal strength
- 6.2. "Tally" displays current TALLY display setting status
- 6.3. "Brightness" displays current screen brightness
- 6.4. "Application" displays the current scene mode setting
- 6.5. "Version" displays the current firmware version

## **7 Select "Exit" and press "OK" to return to the root menu**

# INSTALLATION

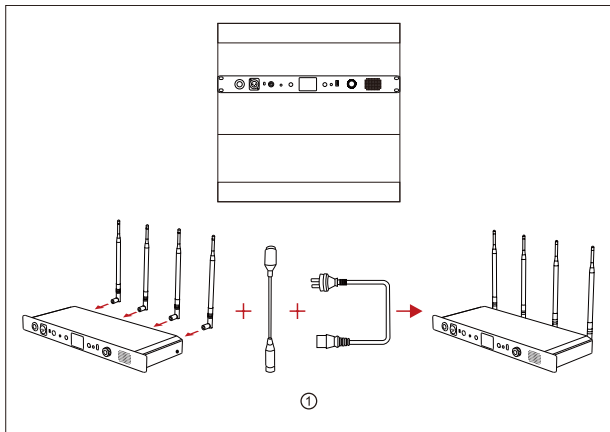

## ① Base Station Installation

1. Install antennas as demonstrated
2. Plug in the gooseneck mic
3. Install the base station in 1U cabinet

# INSTALLATION

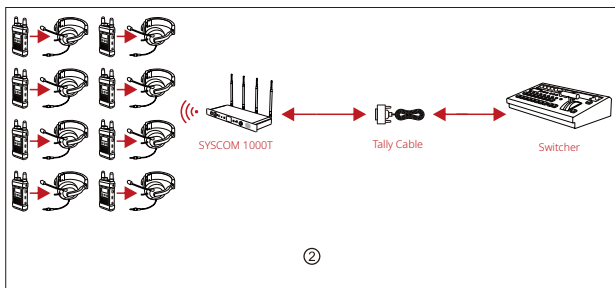

## ② TALLY Function

1. The DB25 TALLY output interface is equipped on the back of the base station, and users can directly plug TALLY convert cable into the TALLY input interface of the switcher. When the switcher selects the on-call beltpack ID and click different TALLY indicator button, the corresponding beltpack will be prompted by displaying a red light or a green light.

# INSTALLATION

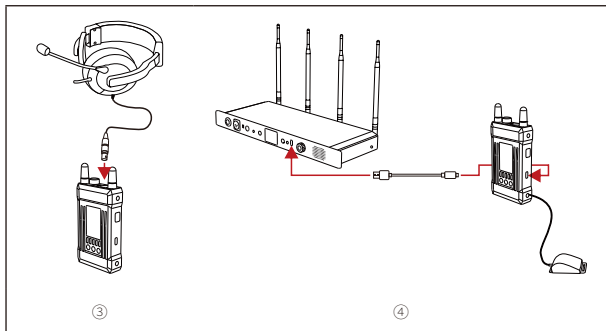

## ③ Beltpack Installation

1. Connect the headset as demonstrated.
2. Turn the power and volume control knob to turn on the beltpack.
3. When the status of the beltpack turns from "LOST" to "MUTE", long-press the "M-MUTE/TALK" button on the side of the beltpack to switch it to "TALK" mode to communicate. If the beltpack operator doesn't want to talk with the base station, double-click the "MUTE/TALK" button on the side of the beltpack to switch to "MUTE" mode. The beltpack operator can still hear the base station and other connected beltpacks under this mode.
4. Click the "MIC MUTE" button to mute all beltpacks if the base station operator doesn't want to hear all beltpacks. When the indicator light is on, all beltpacks are switched to "MUTE" mode. Under this mode, beltpacks' operators can hear the base station but they cannot talk to each other and to the base station. If a beltpack operator wants to communicate with the base station, long-press the "MUTE/TALK" button on the side of the beltpack to call the base station. The "REMOTE MIC KILL" button on base station will flash with a red light. Click the "REMOTE MIC KILL" button again to enable all beltpacks to switch back to "TALK" mode.

# INSTALLATION

## ④ **Beltpack Installation**

5. The default setting of mic is dynamic mic. Users can choose different types of mics based on different applications. Long-press the menu button to enter the interface of mic setting and change the mic type to electret.
6. Due to the noise differences in different applications, it may need some white noise to have better hearing experience. The background noise level can be adjusted by changing the "Application" in the root menu.

## ⑤ **Repairing**

If any beltpack ID is lost while using the system resulted by incorrect operation or other reasons, connect the base station and the beltpack through the standard USB type-C data cable. Enter the pair menu and select a master station vacancy ID for reregistering the beltpack. "Pairing..." will appear on the main interface of the base station and the beltpack. Wait until "Pairing Successful" is displayed on the screen of both the base station and the beltpack before unplugging the cable. The beltpack will then be ready to use again.

# PARAMETERS

	<b>Base Station</b>	<b>Beitpack</b>
<b>Interfaces</b>	4 Antenna Interfaces AC Type Power Base AC Input 4-Pin XLR Male DC Input 3.5mm Headset Interface 8-Pin LEMO Female Headset Interface 3-Pin XLR Female Goose Mic Interface 3-Pin XLR Female Audio in 3-Pin XLR Male Audio out DB25 Female TALLY Input Interface USB Type-A Interface USB Type-C Interface	2 Antenna Interfaces 3.5mm Headset Interface 8-pin LEMO Female Headset Interface 3.5mm TALLY out Interface USB Type-C Interface
<b>Power Supply Mode</b>	10~20V DC Input; 100V~240V AC Input	4000mAh Polymer Lithium Battery
<b>Frequency Response</b>	300Hz to 4KHz	300Hz to 4KHz
<b>Signal to Noise Ratio</b>	> 50dB	> 50dB
<b>Distortion</b>	<2	<2
<b>Transmission Range</b>	300m Between Beltpack and Base Station	300m Between Beltpack and Base Station
<b>Frequency Bandwidth</b>	1.9GHz	1.9GHz
<b>Modulation Mode</b>	GFSK	GFSK
<b>Transmission Power</b>	Maximum 24dBm	Maximum 24dBm
<b>Receiver Sensitivity</b>	≤-93dBm	≤-93dBm
<b>Bandwidth</b>	1.728MHz	1.728MHz
<b>Power Consumption</b>	<6W	<2W
<b>Dimension</b>	(L*W*H): 483*175*45mm	(L*W*H): 120*71*25mm
<b>Net Weight</b>	Around 2900g	Around 300g
<b>Temperature Range</b>	0 ~ +45°C (Working Status) -20 ~ +60°C (Storage Condition)	0 ~ +40°C (Working Status) -20 ~ 60°C (Storage Condition)

# PARAMETERS

## **Safety Note**

Do not place your backpacks on heating equipment, cooking equipment, high-pressure containers (such as microwave ovens, induction cookers, electric ovens, heaters, pressure cookers, water heaters, gas stoves, and etc.) to prevent the battery from overheating and exploding. The charger, data cable, and battery from the original box must be used. Chargers, data cables, or batteries that are not certified by the manufacturer or not from the original box may cause electric shock, fire, explosion, or other hazards.

## **Poor Audio Quality**

1. First confirm whether the beltpack antennas are correctly installed and tightened. If there is no improvement, replace the antennas.
2. Ensure the beltpack and the base station are in the transmission range and there is no obstacle between the main station and the beltpack.
3. Check if the volume of the beltpack is too low and turn it to a comfortable level.
4. Due to the difference in impedance and setting bias, we generally don't recommend customers to use his own 4-stage 3.5mm headset. If the sound quality is poor, replace the headset.

## **Base Station Cannot Display Beltpack Information**

1. First confirm whether the beltpack antennas are correctly installed and tightened. If there is no improvement, replace the antennas.
2. Check the status of the Beltpack. If "LOST" appears on the beltpack screen, make sure that the beltpack is within the transmission range from the base station.
3. Check the status of the beltpack. If it is displayed as "NULL", it means that the beltpack information is lost due to incorrect operation, and it needs to be reregistered.

## **No Sound between the Base Station and Beltpack**



1. Confirm if the "REMOTE MIC KILL" button on the base Station is on. If the red light is on, click on it to turn it off.
2. Check the current status on the beltpack screen. If it's on "MUTE", long press the "MUTE/TALK" button on the side to switch it to "TALK".
3. Check if the headset functions well and if you wear the headset and mic properly. (correct way: put the headset on the head with the mic less than 10cm from your mouth)

### TALLY Function Unavailable

1. Confirm that the type of the switcher is correct. The TALLY interface definition is not unified on most switchers, so it will cause TALLY dysfunction.
2. Due to various types of the switcher, high-level value will work when push the level switch to "High" on the TALLY signal universal converter; low-level value will work when push the level switch to "Low" on the TALLY signal universal converter.
3. Confirm the ID of the beltacks, and check if the TALLY converter connects with the USB Type-A interface on the base station correctly.
4. The beltack only supports external TALLY light. Confirm if the beltack connects to an external TALLY correctly.
5. DB25 interface and tally indicator wiring relation table

Channel	Program	Preview	GND
TALLY 1	PIN1	PIN14	PIN13
TALLY 2	PIN2	PIN15	
TALLY 3	PIN3	PIN16	
TALLY 4	PIN4	PIN17	
TALLY 5	PIN5	PIN18	
TALLY 6	PIN6	PIN19	
TALLY 7	PIN7	PIN20	
TALLY 8	PIN8	PIN21	



-  Hollyland User Group
-  HollylandTech
-  HollylandTech
-  HollylandTech
-  [support@hollyland-tech.com](mailto:support@hollyland-tech.com)
-  [www.hollyland-tech.com](http://www.hollyland-tech.com)

**Shenzhen Hollyland Technology Co., Ltd.**

---

8F, 5D Building, Skyworth Innovation Valley, Tangtou, Shiyan, Baoan District Shenzhen, China.