



# HP Latex 126-in Roll-to-Freefall Kit

## User guide

### SUMMARY

How to use your product.



## About this edition

© Copyright 2024 HP Development Company, L.P.

Edition 2, November 2024

### **Legal notices**

The information contained herein is subject to change without notice.

The only warranties for HP products and services are set forth in the express warranty statement accompanying such products and services. Nothing herein should be construed as constituting an additional warranty. HP shall not be liable for technical or editorial errors or omissions contained herein.

### **Safety notice**

Read and follow the operating and safety instructions before starting the printer.

---

# Table of contents

<b>1 Introduction</b> .....	<b>1</b>
<b>2 Substrate configurations</b> .....	<b>2</b>
Load a roll (roll-to-freefall configuration).....	2
Load a roll (roll-to-collector configuration) .....	5
<b>3 Hardware maintenance</b> .....	<b>8</b>
Clean the roll-to-freefall roller and pinchwheels .....	8
Prepare to clean the roll-to-freefall roller and pinchwheels.....	8
Clean the roll-to-freefall roller .....	8
Clean the pinchwheels .....	9
<b>4 Printcare diagnostics</b> .....	<b>11</b>
Diagnostics for operator (HP Latex 1500 Printer).....	11
Diagnostics for operator (HP Latex 2700/FS50/FS60 printer series).....	11
<b>5 Roll-to-freefall system errors and alerts</b> .....	<b>12</b>

---

# 1 Introduction

The HP Latex 126-in Roll-to-Freefall Kit allows you to start the finishing process on one print while printing the next.

Ideal for short runs or one-off jobs, the printer remains productive while you are completing jobs. The roll-to-freefall configuration allows you to cut and remove prints as soon as they come off the printer, so that you can finish and deliver quickly.

This accessory is compatible with the HP Latex 1500 Printer and the HP Latex 2700/FS50/FS60 printer series.

---

## 2 Substrate configurations

The substrate can be loaded in a variety of different configurations to suit your different needs.

Before loading substrate, go to the Internal Print Server and select **Substrate load/unload**, then select the configuration you intend to use.

With the roll-to-freefall kit installed, you can work with the roll-to-freefall configuration.

The roll-to-freefall configuration is suitable when you want to cut and remove one or more prints as soon as they come out of the printer. The substrate is kept under tension between the input roll and the tension roller, but it can be cut after the tension roller, because then it is no longer under tension.

### Load a roll (roll-to-freefall configuration)

The substrate roll is mounted on the input spindle; the printed substrate will be deposited on the floor in front of the printer.



---

 **NOTE:** This video applies to HP Latex 800, HP Latex 1500, HP Latex 2700/FS50/FS60 series, and HP Latex 3000 series printers.

---

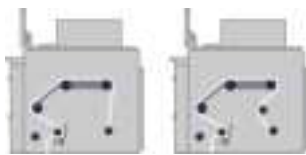

The substrate goes from the input spindle over the main roller, over the platen, over the front diverters, and then to the tension roller, after which it continues to the floor.

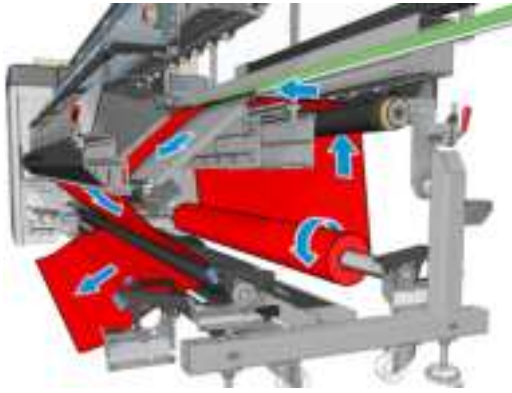

You can load substrate with the printed face inwards or outwards on the spindle, in which case the spindle will turn in the opposite direction. The printer asks you for the winding direction if it cannot detect it automatically.

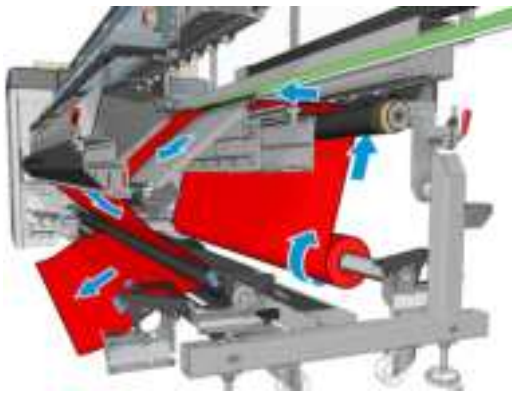

Before loading a roll into the printer, you must have a roll loaded onto the input spindle. See **Load a roll onto the spindle** in the printer user guide.

---

**TIP:** The spindle by itself is quite heavy, and a roll of substrate can be much heavier. You are recommended to use a forklift or some other equipment to move it into position; otherwise, lift one end into the printer, and then the other end.

---

To load the substrate, follow the same procedure as in the roll-to-roll configuration, except that the output spindle is not needed.

1. Ensure that the tension roller lever is raised.



2. Unlatch the tension roller at both ends.



3. Move the roller to the front, so that you have more space to pass the substrate behind the roller.



4. Pass the substrate through and push the roller backwards, taking care not to trap your fingers between the roller and the black substrate guide lying underneath and behind.
5. Close the latches at both sides.
6. Align the substrate by checking that the substrate edge is in the same position on the input spindle and tension roller. This can be done by using the rulers on the spindle and tension roller or by measuring the distance between the right edge and the side plate.
7. Ensure that the substrate is evenly tensioned and flat (no wrinkles or bumps), and close the tension roller lever.
8. Go to the Internal Print Server and click or tap the **Finish** button as in the roll-to-roll configuration.

## Load a roll (roll-to-collector configuration)

This configuration is similar to the roll-to-freefall configuration, but with the addition of a collector roller and tension bar.

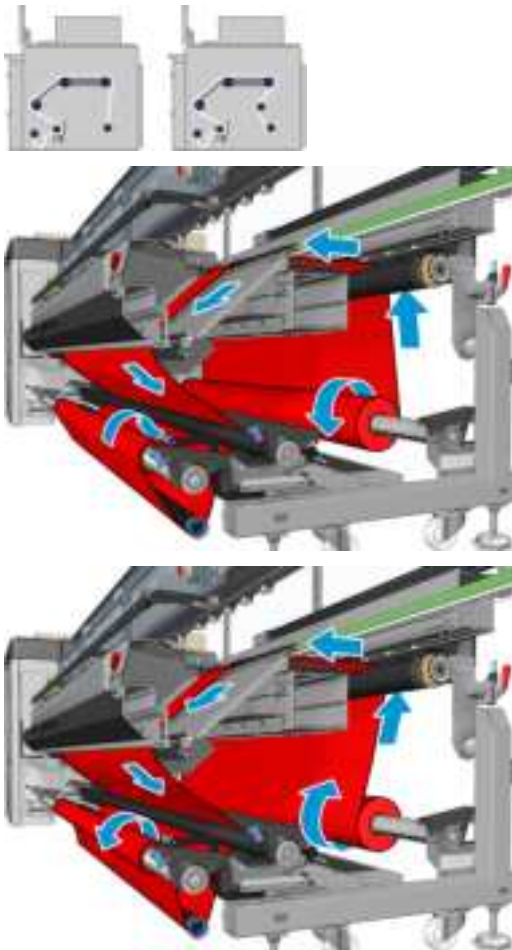

**TIP:** Do not try to load or unload the collector while printing.

Before starting to load the substrate, select a tension bar of the correct length to match the substrate width. The following tubes are supplied so that you can make up tension bars of many different lengths.

- One 152-mm (6-in) tube
- Two 203-mm (8-in) tubes
- One 305-mm (12-in) tube
- One 610-mm (24-in) tube
- Two 1067-mm (42-in) tubes
- Two end flanges, to be placed at each end to avoid lateral displacement of the tension bar during printing

For example, you can make up the following tension bars.

- 914 mm (36 in): 610-mm (24-in) and 305-mm (12-in) tubes

- 1016 mm (40 in): 610-mm (24-in) and two 203-mm (8-in) tubes
  - 1270 mm (50 in): 1067-mm (42-in) and 203-mm (8-in) tubes
  - 1372 mm (54 in): 1067-mm (42-in) and 305-mm (12-in) tubes
  - 1524 mm (60 in): 1067-mm (42-in), 305-mm (12-in) and 152-mm (6-in) tubes
  - 1829 mm (72 in): 1067-mm (42-in), 610-mm (24-in) and 152-mm (6-in) tubes
  - 1981 mm (78 in): 1067-mm (42-in), 610-mm (24-in) and two 152-mm (6-in) tubes
  - 2032 mm (80 in): 1067-mm (42-in), 610-mm (24-in), 203-mm (8-in) and 152-mm (6-in) tubes
  - 2489 mm (98 in): two 1067-mm (42-in), 203-mm (8-in) and 152-mm (6-in) tubes
  - 2642 mm (104 in): two 1067-mm (42-in), 305-mm (12-in) and 203-mm (8-in) tubes
  - 3200 mm (126 in): two 1067-mm (42-in), 610-mm (24-in), 305-mm (12-in) and 152-mm (6-in) tubes
1. Follow the whole loading procedure for the roll-to-freefall configuration.
  2. Load an empty substrate core onto the output spindle. For dual-roll printing, load two cores of the same diameter onto a single spindle (it is not recommended to use a dual-roll spindle as the collector).
  3. Use the buttons in the Internal Print Server to advance the substrate's leading edge until it reaches the core on the collector.
  4. Tighten the substrate so that it is evenly tensioned, then attach the leading edge to the core with tape, first at the center and then at the sides. There should be no wrinkles or slackness across the substrate.
  5. Use the buttons in the Internal Print Server again to advance the substrate so that a substrate loop is produced between the tension roller and the collector.
  6. Place the tension bar into the substrate loop.

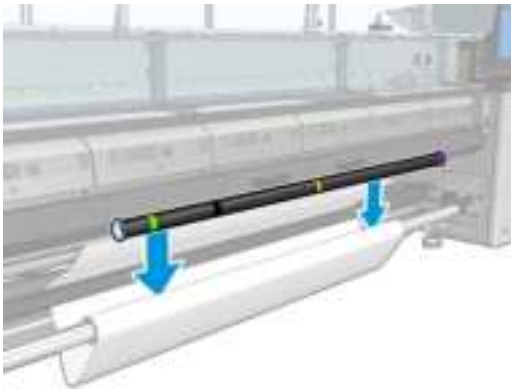

---

 **NOTE:** Loop detection is done in the center of the printer; so avoid putting your foot or any other object under the collector in the center.

---

7. Go to the Internal Print Server and click the **Enable collector** button (for the HP Latex 1500), or tap the **Take-up reel** button (for the HP Latex 2700/FS50/FS60 series).

8. Select the winding direction: **Outwards** is recommended, as it permits an output roll up to 300 mm (11.81 in) in diameter. If you select **Inwards**, the diameter of the output roll is limited to 200 mm (7.87 in): with a fatter roll, the tension bar would start to touch the roll.

---

 **NOTE:** The winding direction cannot be changed on the fly: the collector has to be deactivated and reactivated.

---

9. Click or tap the **Finish** button.

The printer is now ready to print.

---

## 3 Hardware maintenance

The following sections provide details for this topic.

### Clean the roll-to-freefall roller and pinchwheels

The roll-to-freefall roller should be cleaned whenever it is visibly dirty (for instance, whenever ink has not cured properly when using the roller), or when you notice that substrate advance is no longer smooth and regular (for instance, if you notice that the roller often slips when trying to keep the substrate under tension).



Risk of burns



Crush hazard



Risk of trapped fingers

---

For more safety information, see **Safety precautions** in the printer's user guide.

---

### Prepare to clean the roll-to-freefall roller and pinchwheels

The following steps provide the complete procedure for this topic.

1. Check that the printer is not printing.
2. Unload the substrate.
3. Raise the pressure roller lever if it was previously lowered.

### Clean the roll-to-freefall roller

The following steps provide the complete procedure for this topic.

1. Clean the roller with a clean cloth dampened with water (for persistent dirt you may use isopropyl alcohol, but do not use petroleum-based cleaning liquids).



2. Turn the roller manually and keep cleaning to make sure the rubber surface of the roller is cleaned all around.

**⚠ WARNING!** Take care not to trap your finger when turning the roller.



3. Ensure that the cleaned parts are completely dry and the vapors have completely evaporated.

## Clean the pinchwheels

The following steps provide the complete procedure for this topic.

1. Open the roller latches at both sides and move the roller to the front.
2. Lower the pressure roller lever so that the pinchwheels are accessible.



3. Clean the pinchwheels carefully with a cloth dampened with water (for persistent dirt you may use isopropyl alcohol, but do not use petroleum-based cleaning liquids).



4. Once the pinchwheels are clean, raise the pressure roller lever.
5. Roll the roller backwards by pushing it (not by grabbing it).

---

**⚠ WARNING!** Take special care when moving the roller backwards not to hit your fingers against the black substrate guide behind and under the roller.

---



6. Once the roller is in position, close the latches at both sides.
7. Ensure that the cleaned parts are completely dry and the vapors have completely evaporated.

## 4 Printcare diagnostics

The following sections provide details for this topic.

### Diagnostics for operator (HP Latex 1500 Printer)

You can run these diagnostics only if the roll-to-freefall kit is installed.

**Table 4-1** Roll-to-freefall kit

Alert	Recommendation
41011 Electronic check	This diagnostic allows you to check the connectivity with the electronic parts in the kit.
41012 Sensors check	This diagnostic allows you to check the status of the sensors in the kit (tension-roller latch, tension-roller lever, substrate-collector sensor).
41013 MF and MO motors check	This diagnostic makes automatic checks on the substrate floor motor and substrate output motor.

### Diagnostics for operator (HP Latex 2700/FS50/FS60 printer series)

You can run these diagnostics only if the roll-to-freefall kit is installed.

**Table 4-2** Roll-to-freefall kit

Alert	Recommendation
41102 Electronic check	This diagnostic checks the electronic connections required for the roll-to-freefall kit to work: <ul style="list-style-type: none"><li>• Power Supply Unit 1 (PSU 1) is in range.</li><li>• Fuse for the PSU 1 is working.</li><li>• Connection to the e-box interconnect PCA is working.</li></ul>
41103 Sensors check	This diagnostic checks that the following sensors are working properly: <ul style="list-style-type: none"><li>• Loading-table-latch sensors</li><li>• Take-up-reel sensor</li><li>• Pinch-lever switch sensor</li></ul> <p>It checks the performance of the sensors when pulling and pushing the latches and levers, and blocking and unblocking the substrate-collector sensors. When the sensors are working correctly, it shows the changes in sensor status.</p>
41104 Media Floor motor check	This diagnostic performs a direction test of the substrate floor motor and the substrate front motor.

## 5 Roll-to-freefall system errors and alerts

Under certain circumstances, the Internal Print Server displays a numeric error code. Follow the recommendations here to resolve the error.

The error codes listed here are in addition to those appearing in the main printer documentation. If an error code appears that is not included in either list, turn off the printer and then turn it back on. If the problem persists, call your service representative.

### System errors and alerts for the HP Latex 1500 Printer

Error	Recommendation
10.04.12:10 E-cabinet MF fuse blown	The substrate floor motor 42 V fuse (F11) in the e-cabinet PCA has blown. Probably there is a short-circuit in that subsystem or its power cabling. Install a new F11 fuse. If the problem persists, call your service representative.
10.05.12:40 E-cabinet MF power output overload	The substrate floor motor 42 V switch in the e-cabinet PCA is overloaded. Probably there is a short-circuit in that subsystem or its power cabling. Restart the printer. If the problem persists, call your service representative.
41.05.00:51 Pinchwheels are up	Ensure that the pinch bar is lowered (by using the tension-roller lever). If the problem persists, run the sensors check diagnostic (41012) to check whether the sensor is working. If it is not, call your service representative.
41.05.01:51 Tension roller latch open	Close the tension-roller latches at both ends. Make sure they are properly closed. If the problem persists, run the sensors check diagnostic (41012) to check whether the sensor is working. If it is not, call your service representative.
41.05.00:61 Tension roller not moving	Reload the substrate, and run the motors diagnostic (41013) if the problem persists.
41.10.01:08 Possible take-up-reel jam, optical sensor never detects substrate	Check that the substrate-collector sensor works correctly and that there is no object blocking its line of sight. If the problem persists, run the sensors check diagnostic (41012) to check whether the sensor is working. If it is not, call your service representative.

### System errors and alerts for the HP Latex 2700/FS50/FS60 printer series

Error	Recommendation
0010-0012:1215 E-cabinet MO/MF fuse blown	The substrate floor motor 42 V fuse (F12) in the e-cabinet PCA has blown. Probably there is a short-circuit in that subsystem or its power cabling. Install a new F12 fuse. If the problem persists, call your service representative.
1041-0006-0359 MF motor servo shutdown	Substrate floor motor servo shutdown. Probably there is a jam in the system or a problem related to the motor or encoder. If the problem persists, call your service representative.
1041-0006-0360 MF motor direction test fail	The substrate floor motor is unable to move while the printer is starting up. This could be caused by a defective motor or encoder. If the problem persists, call your service representative.
1041-0010-0008 TUR sensor jam detected	Check that the substrate-collector sensor works correctly and that there is no object blocking its line of sight. If the problem persists, run the sensors check diagnostic (41012) to check that the sensor is working. If it is not, call your service representative.

Error	Recommendation
1041-0010-0009 TUR sensor not connected to e-box interconnect PCA	Check that the TUR sensor cable is properly connected to the J49 connector on the e-box interconnect PCA. If the problem persists, call your service representative.
1041-0013-0009 RTFF switches not connected to e-box interconnect PCA	Check that the roll-to-freefall switches sensor cable is properly connected to the J32 connector on the e-box interconnect PCA. If the problem persists, call your service representative.