



1000W



**USER
MANUAL**
**DE CMH FIXTURE MODEL
1000W 208-277V**

IL-CMHDE1000-240

877-540-5588
iluminarlighting.com
sales@iluminarlighting.com

THANK YOU for purchasing an **ILUMINAR Lighting CMH FIXTURE**. We strive to deliver the best customer service alongside world-class products and we go above and beyond to make sure you are satisfied with your purchase. The following is a general set of warnings and basic guidelines for the ILUMINAR Lighting CMH DE Fixture. Always have an expert install your product(s).

KEEP ORIGINAL PACKAGING

In the event of a return, products will need to be in the original ILUMINAR Lighting packaging to avoid product damage during shipping. Any damage to products not in their original packaging will not be covered under the Warranty. Visit iluminarlighting.com/warranty for more detailed information.

⚠ SAFETY 1ST

FAILURE TO OBSERVE THE FOLLOWING WARNINGS COULD RESULT IN ELECTRICAL SHOCK AND SERIOUS INJURY. Additionally, failure to follow these safety warnings can/will result in a void of all warranties as well as any manufacturer liability.

Please read carefully prior to beginning installation.

WARNINGS

- ⚠ Make sure the power cord is correctly connected and the lamp is securely in place.
- ⚠ Disconnect the fixture from the power supply prior moving the unit or performing any maintenance or lamp changes.
- ⚠ DO NOT open the ballast case, it will void the warranty.
- ⚠ DO NOT support the ballast by power cord(s). These cords/connections are not designed to bear weight.
- ⚠ DO NOT make contact with the interior of the socket while power is on.
- ⚠ DO NOT attempt to rewire, alter, modify or reconfigure your system - this will void the ILUMINAR warranty and could create serious safety hazards, or cause bodily injury or death, as this is a high amperage and voltage device.
- ⚠ DO NOT submerge in water.
- ⚠ DO NOT plug the system into untested or unidentified voltage other than what is designated on ballast.
- ⚠ DO NOT CONNECT A CMH BALLAST to a Flip Box. It will void the warranty and can cause electrical failure within the CMH Ballast. Flip or Switch Boxes are not recommended for any CMH Units or for any high wattage ballasts.
- ⚠ DO NOT plug or unplug the lamp cord while the ballast is connected to power.
- ⚠ Make sure to wear proper gloves to protect from the transfer of oil from the skin to the lamps glass surface.
- ⚠ When changing out the lamp, make sure that the lamp has time to cool before touching.
- ⚠ Make sure the lamp is correctly locked into the socket, properly securing the lamp.
- ⚠ If the lamp is damaged in any way (cracked, loose internal connections) replace the lamp immediately.
- ⚠ Keep away from Children. This product contains delicate electronic components. If it is placed near an object that transmits radio signals, it could cause interference (i.e.: mobile devices, walkie talkies, CB radios, remote controls and microwaves). If interference occurs, move such objects away from the appliance.

- ◀ Energy efficient
- ◀ Uniform Light Distribution
- ◀ Soft Start Technology
- ◀ Ignition Failure Protection



TECHNICAL SPECS	208V	240V	270V
Input Current	5.10A	4.60A	3.85A
Input Power	1045W		
Rated Voltage	208-277V		
Voltage Range	187-290V		
Ignition Voltage	5KV		
THD	<15%		
Min Power Factor	0.95		
Crest Factor	1.7		
Input Connection	IP67 Wieland Plug		
Frequency	50-60HZ		
Operation frequency	140-220HZ		
Relative Humidity	95% (Non-condensing)		
Operation Temp	0 - 35°C / 32-95°F		
Recommended Lamp	ILUMINAR CMH 1000W DE		
Socket Type Lamp Base	K12x30s - / Style		
Minimum Mounting Height	1.2m / 4'		

Lamp Not Included.

PHYSICAL SPECIFICATIONS

Case Length	564mm	22.22"
Case Width	249mm	9.80"
Height	601mm	23.66"
Weight	6.6kg	14.55lb

MOUNTING & COVERAGE

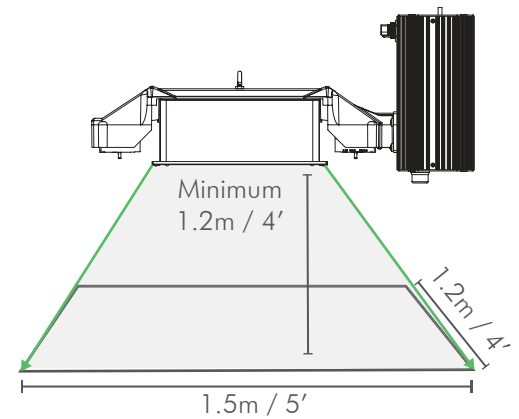

DIMENSIONS

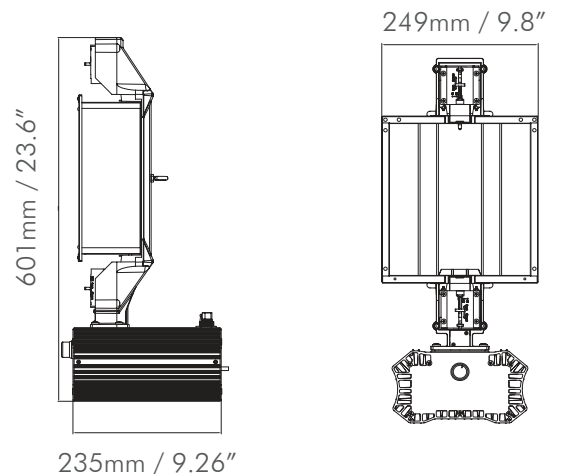

INSTALLATION PROCEDURE

PLEASE READ CAREFULLY PRIOR TO INSTALLATION

When possible, have a licensed electrician or electrical expert install all fixtures or aid in the electrical layout plans and/or diagrams prior to installation.

Check the electrical panel to ensure proper voltage is available for the number of fixtures installed. Panels should only support a total amperage of 80% of its capacity. (100 amp panel should never exceed 80 amps).

1. Find a suitable location for the fixture with sufficient cooling and away from heat sources.
2. Use the included hanging cables to hang the fixture.
3. Ensure the fixture is hung completely level to the ground. A fixture that is not level can burn the lamp emitter incorrectly leading to shorter lamp life, poor lamp performance and/or lamp failures.
4. Install the lamp into the roll-lock socket (instructions pages 6-7) using soft cotton or surgical gloves.
5. Plug the power cord into the power source (electrical outlet).
6. For proper lamp break-in, we recommend that you run the fixture at 100% power for at least 100 straight hours after initial startup. This will improve lamp life and performance.
7. Set your desired dimming ratio. NOTE: the ballast dims or raises output gradually to protect the lamp, so you may not see an instant increase upon changing your output percentage.

PERFORMANCE REQUIREMENTS

RATED VOLTAGE	208-277V
VOLTAGE RANGE +/- 10%	187-290V
FREQUENCY	50 - 60Hz
OPERATIONS FREQUENCY	140-220HZ

COMPATIBILITY

Compatible with all ILUMINAR Lighting CMH DE lamps as well as the ILUMINAR Lighting Touch & ILUMINAR Lighting HASH Environment controllers.

DIMMING

- Turn the dimming dial to cycle through the dimming levels.
- If your lamp fails to start immediately, **DO NOT** cycle the power on and off. This can damage the lamp and ballast.
- If after 30 minutes your lamp is still not lit, shut off power to the ballast, and reconnect.
- This will begin the startup sequence again.
- Until the lamp has achieved at least 100 hours of operation, the lamp should never be turned off prior to running at least 15 minutes. In case this happens, **WAIT 1 hour** before igniting the lamp again.

HOT RESTRIKE

IT IS VERY IMPORTANT that the lamp is given adequate time to cool down before it is reignited. Allow a hot lamp to cool for 1 hour before you try to restrike it. Hot re-strikes cause permanent lamp failure and lumen output degradations. The lamp should never be turned off before the lamp reaches full intensity, this may shorten its lifespan.

MOUNTING LOCATION

DO NOT install fixtures in areas of high heat, such as an attic, tent or closed closet. Mount units at least 24-60 inches apart.

BALLAST PROTECTIONS

1. End of Lamp Life (EOL) Protection
2. Short Circuit Protection
3. Open Circuit Protection
4. Ignition Failure Protection
5. Thermal Protection
6. Suitable for ILUMINAR Lighting Touch+ Controller
7. Suitable for HASH Controller / 0-10V Control
8. Total Control Range 50-115%

PHYSICAL SPECIFIC

CASE LENGTH	564mm	22.22"
CASE WIDTH	249mm	9.80"
HEIGHT	601mm	23.66"
WEIGHT	6.6kg	14.55 lbs

CARE

1. Max. allowable case temperature: 35° C / 95° F
2. Ambient Temperature: 0 - 35°C / 32-95°F
3. Max. Humidity: 95%
4. Ignition Voltage: 5kV

FIXTURE DIAGRAM

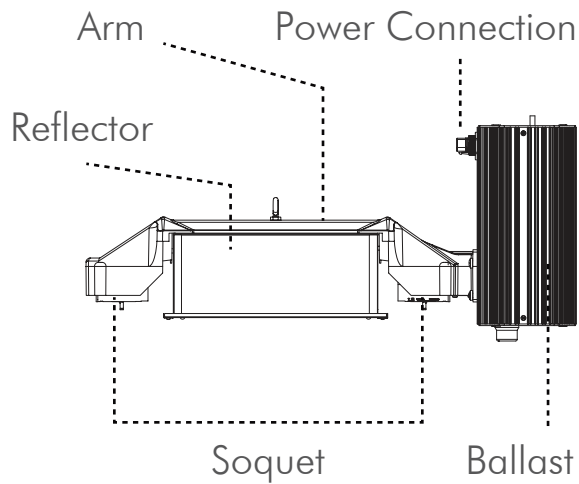

PROTECTIONS

- Microprocessor Driven
- End of Lamp Life (EOL)
- Open Circuit Protection
- Ignition Failure Protection
- Thermal Sensing Protection

WIRING DIAGRAM

NAME	VOLTAGE	SKU	DIAGRAM
Power Cord Wieland Female to Male	120V	IL-WLDCRD-120V	
Power Cord Wieland Female to Male	240V	IL-WLDCRD-240V	
Power Cord Wieland Female to Male	277V	IL-WLDCRD-277V	
Power Cord Wieland Female to Male	347V	IL-WLDCRD-347V	

- RJ14 Controller Connection
- Wieland Female
- Wieland Male

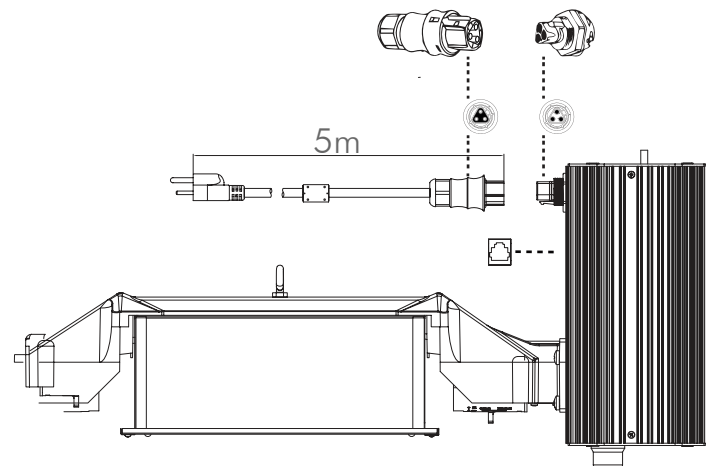

TOUCH CONTROLLER DAISY CHAIN DIAGRAM

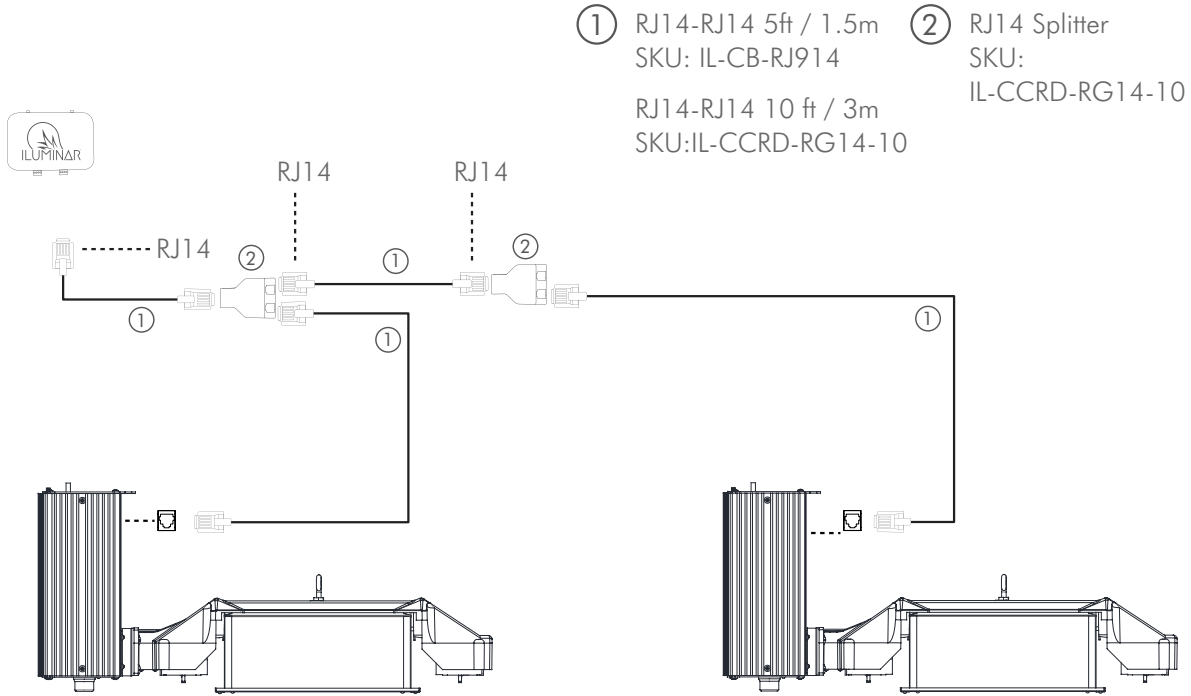

HASH CONTROLLER DAISY CHAIN DIAGRAM

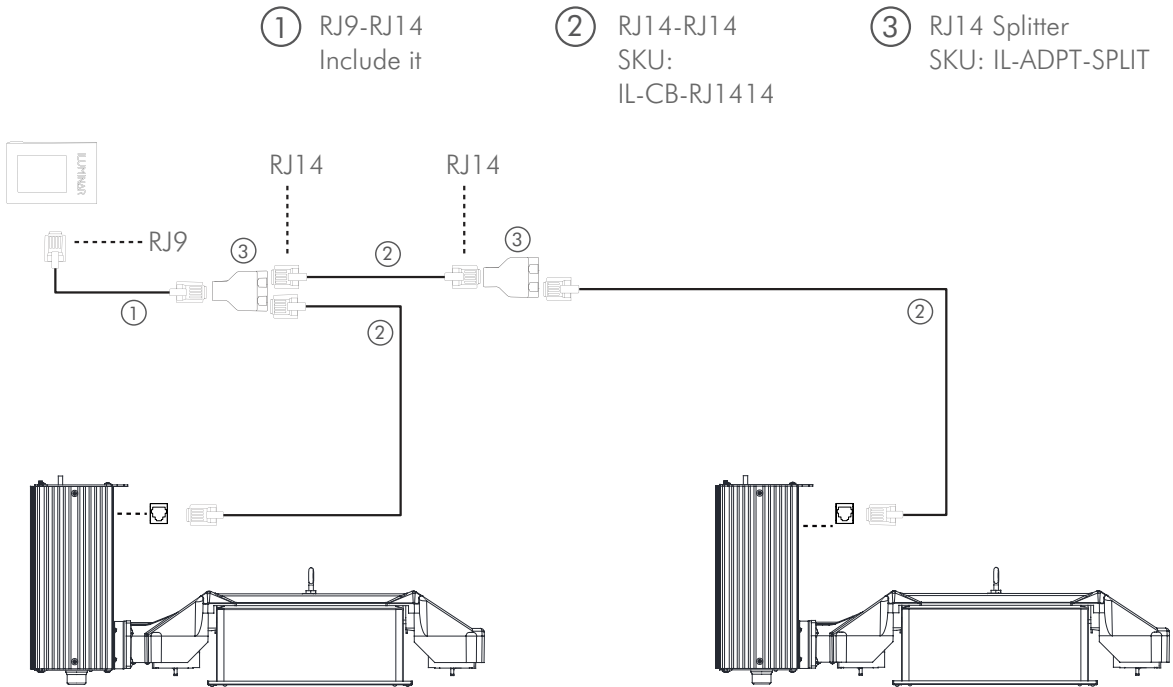

TROUBLESHOOTING

Follow these troubleshooting solutions:

Possible Cause

Corrective Maintenance

Lamp Loose in Socket	Ensure the lamp is fully inserted into the socket and that it has been properly locked.
Incorrect Voltage	Make sure you're using the correct input voltage with ballast. If using incorrect voltage, disconnect the ballast from the power source immediately.
Defective or Improper Wiring	Examine wiring to ensure it agrees with wiring diagrams on ballast label. Check connections to see that they are secure. If wiring a ballast, DO NOT use a neutral. The correct wiring is two hot wires and a ground.
Poor electrical connections	Check wiring and lamp contact with socket.
Incorrect Lamp	Verify that you're using a correct wattage lamp.
Lamp Damage	Investigate possibility of outer lamp damage. Look for broken tubes or loose metal replace lamp.

RETURNS

WARRANTY

Please contact your point of purchase store for returns.

When properly used, this unit will provide you with years of service. The ballast is covered under a 3 year warranty and the lamp has a 1 year warranty. This warranty will be voided if the unit is misused, abused, opened or altered. Warranty repair or replacement will be at the sole discretion of the manufacturer. Defective units need to be returned to the place of purchase with proof of purchase/receipt.

For more warranty information, visit iluminarlighting.com/warranty

CERTIFICATIONS



This guide does not supersede national, state, or local regulations for electrical installations.