



HIGH-EFFICIENCY HEAT RECOVERY UNIT
WITH INTEGRATED AIR TREATMENT

INDEX

1	GENERALITY.....	4
1.1.1	INTRODUCTION.....	4
1.1.2	BASIC SAFETY RULES	4
1.1.3	SYMBOLOLOGY	5
1.1.4	CAUTION WARNINGS.....	5
1.1.5	COMPLIANCE.....	6
1.1.6	RANGE.....	6
1.1.7	IDENTIFICATION	6
1.1.8	CONSTRUCTION FEATURES.....	7
1.1.9	MAIN COMPONENTS OF THE UNIT.....	8
1.1.10	PACKAGING AND TRANSPORTATION.....	9
1.1.11	RECEIVING CONTROL AND HANDLING	9
1.1.12	DISASSEMBLY AND DISPOSAL	9
2	INSTALLATION.....	10
2.1.1	CONDITION OF INSTALLING	10
2.1.2	UNIT POSITIONING.....	10
	CONDENSATE DRAIN CONNECTION	11
3	AREAULIC CONNECTIONS.....	12
3.1.1	AREAULIC CONNECTIONS.....	12
4	PLUMBING CONNECTIONS.....	13
4.1.1	GENERALITY	13
4.1.2	POSITIONING AND PROCEDURES OF CONNECTIONS.....	13
4.1.3	2-3 WAY VALVE CONNECTION.....	14
5	ELECTRICAL CONNECTIONS	14
5.1.1	GENERALITY	14
5.1.2	PLACEMENT AND PROCEDURES OF LINKS	15
5.1.3	UNIT WIRING DIAGRAMS.....	16
5.1.4	ELECTRICAL CONNECTIONS VERSION -I-.....	17

ESSA I	20
5.1.5 OPERATION VERSION -I-	20
5.1.6 SWITCHING THE UNIT ON AND OFF	20
5.1.7 MOISTURE AND IAQ DISPLAY	20
5.1.1 CHANGING FAN SPEEDS AND BOOSTER FUNCTION.....	21
5.1.2 NOMINAL SPEED FUNCTION.....	21
5.1.3 SEASON CHANGE	21
5.1.4 KEY LOCK.....	21
5.1.5 ADJUSTMENT OF PANEL BRIGHTNESS.....	22
5.1.6 SET POINT TEMPERATURA PER CONTROLLO BATTERIA DI POST	22
5.1.7 SET POINT IAQ AIR QUALITY REGULATING AIR FLOW AUTO.....	22
6 MAINTENANCE.....	23
6.1.1 CLEANING OR REPLACING FILTER.....	23
6.1.2 HEAT EXCHANGER CLEANING.....	23
6.1.3 GENERALE CLEANING OF THE UNIT	24
7 ALARM.....	25
7.1.1 GENERALITY	25
7.1.2 PROBLEMS WITHOUT DISPLAY ERROR INDICATION	25
7.1.3 ALARM WARNING.....	26
7.1.4 ALARM TABLE DISPLAYED - VERSION I-.....	26
8 MAINTENANCE NOTES AND INFORMATION	27

1.1.1 INTRODUCTION

This manual is designed with the goal of making it as easy as possible to install and operate your system.

By reading and applying the suggestions in this manual, you will achieve the best performance of the product you have purchased.

We would like to thank you for the choice you have made by purchasing our product.

Please read this booklet carefully before performing any operation on the 'unit.

You should not install the unit, in performing any work on it, if you have not first carefully read and understood this manual in all its parts. In particular, all precautions listed in the manual should be taken.

Documentation accompanying the unit should be given to the person in charge of the installation to keep carefully (at least 10 years) for possible future servicing, maintenance and repair.

The installation of the unit must take into account both purely technical requirements for proper operation and any applicable local legislation and specific requirements.

Make sure that upon delivery of the unit, there are no obvious signs of damage caused by transportation. If so, indicate this on the delivery note.

This manual reflects the state of the art at the time the machine was marketed and may not be considered inadequate because it has been subsequently updated based on new experience. The Manufacturer reserves the right to update production and manuals, with no obligation to update previous ones except in exceptional cases.

Please contact the Manufacturer's Sales Department for further information or updates to the technical documentation and for any suggestions for improvements to this manual. All reports received will be rigorously screened.

1.1.2 BASIC SAFETY RULES







Recall that the use of products using electricity and water involves observing certain basic safety rules:

- It is forbidden for incapacitated and unassisted persons to use the device
- It is prohibited to touch the appliance with bare feet and with wet or damp body parts
- It is prohibited to carry out any cleaning operation, before disconnecting the appliance from the power supply by setting the main switch of the system to off
- It is prohibited to modify safety or control devices without the authorization and instructions of the appliance manufacturer
- It is prohibited to pull, unplug, twist the electrical cables coming out of the appliance, even if the appliance is disconnected from the power supply. È vietato introdurre oggetti e sostanze attraverso le griglie di aspirazione e mandata d'aria.
- It is forbidden to open the access doors to the internal parts of the unit without first setting the main switch of the system to off.
- It is forbidden to disperse and leave the packaging material within reach of children as it can be a potential source of danger.
- Observe safe distances between the machine and other equipment or structures to ensure sufficient access space to the unit for maintenance and servicing as indicated in this booklet.
- Power to the unit must be supplied with electrical cables of adequate cross-section for the unit's output. The voltage and frequency values must correspond to those indicated for the respective machines; all machines must be grounded as per current regulations in the various countries.
- Do not release R134A into the atmosphere: R134A is a fluorinated greenhouse gas, recalled in the Kyoto Protocol, with a global warming potential (GWP)=1975.







1.1.3 SYMBOLOGY





The symbols in the following booklet, allow you to quickly provide information necessary for the correct use of the unit.

Symbology related to safety

	WARNING Only authorized personnel	Warns that the indicated operations are important for the safe operation of the machines
	DANGER Risk of electrical shock	Warns that failure to comply will result in a risk of electric shock.
	DANGER	Warns that failure to comply poses a risk of harm to exposed persons.
	CAUTION WARNING	Warns that failure to comply poses a risk of damage to the unit or facility.
	DANGER	Warns that there is the presence of moving parts and poses a risk of harm to exposed persons

1.1.4 CAUTION WARNINGS

	The installation of the unit must be carried out by qualified and licensed personnel according to the regulations in different countries. If the installation is not performed, it could become a dangerous situation
	Avoid installing the unit in rooms that are very humid or have large heat sources.
	On the electrical side to prevent any risk of electrocution, it is essential to disconnect the main switch before making electrical connections and any maintenance operations.
	In case of water leakage inside the unit, set the system main switch to "Off", close the water taps water and contact the technical service
	A dedicated power supply circuit is recommended; never use a power supply shared with other equipment.
	It is recommended that an earth leakage breaker be installed; failure to do so could result in electric shock.
	For connection, use a cable of sufficient length to cover the entire distance, without any connection; do not use extension cords and do not apply other loads on the power supply but use a dedicated power supply circuit.

	After connecting the electrical cables, make sure that the cables are arranged so as not to exert excessive forces on the covers or electrical panels; incomplete connection of the covers may cause the terminals to overheat.
	Ensure that ground connection is made; do not ground the unit on distribution piping. Momentary high overcurrents could damage the unit
	Installations performed outside the warnings in this manual or use outside the operating limits will void the warranty instantaneously.
	Ensure that the first start-up is carried out by personnel authorized by 'the company (see first start-up request form)

1.1.5 COMPLIANCE

The CE marking (found on each machine) certifies compliance with the following EU standards:

- Low Voltage Directive 2014/35/EC
- Electromagnetic Compatibility Directive 2014/30/EC
- Ecodesign 2009/125/EC
- RoHS2 2011/65/UE
- RAEE 2012/19/EC

1.1.6 RANGE

	-1-	-2-
HRW	30/15	I

1) Defines flow rates

30/15 ; 300mc/h total / 150 of renewal

50/25 ; 500mc/h total / 250 of renewal

60/15 ; 600mc/h total / 150 of renewal

90/25 ; 900mc/h total / 250 of renewal

2) Electronic type

I : Simplified electronics

E : Advanced electronics

1.1.7 IDENTIFICATION



- The unit is identifiable by the nameplate on the lower front panel of the unit.
- There will be an additional identification plate on the packaging with the unit model and shipping references.
- The plate on the packaging is not valid for tracking the product in the years following the sale.

The 'removal, deterioration and illegibility of the nameplate placed on the unit, involves great problems in the identification of the machine, in the availability of spare parts and therefore in any future maintenance of it.

1.1.8 CONSTRUCTION FEATURES

RECOVERY SECTION:	Polypropylene counterflow heat exchanger with high efficiency >90%. Summer and winter operation.
VENTILATION:	Plug-fan Brushless plug-fans with electronic motor and modulating control. Very high efficiency and low noise levels Compliant with Erp2015.
AIR HANDLING SECTION:	The unit is equipped with water coil with optimized geometry for dehumidification or integration of cooling and heating. Operation takes place at various supply water operating temperatures.
FILTRATION:	Epm1 80% filters on fresh air and stale exhaust air upstream of heat recovery. Coarse filters with low pressure drop easily removed on recirculating air.
STRUCTURE:	Panels made of double sandwich panel, with painted finish outside and galvanized finish inside the unit. Self-supporting perimeter structure made of galvanized sheet metal. Panel insulation is made of 20mm-thick high-performance insulation and 6mm-thick adhesive polyethylene insulation.
ADJUSTMENT:	VERSION I On-board electrical panel with microprocessor and dedicated control. Fan management, room temperature control and desired room set point. Recirculation management, antifreeze function and water-side on-off valve management. Simplified Touch control panel. ELECTRONIC VERSION On-board electrical panel with microprocessor and dedicated control. Fan management, internal machine temperature probe display, timed dirty filter management, recirculation and fresh air management. Large black-and-white or color touch graphic interface with configuration menu and multilingual user menu. Provision for MODBUS RTU RS 485 communication with a variety of home automation systems.

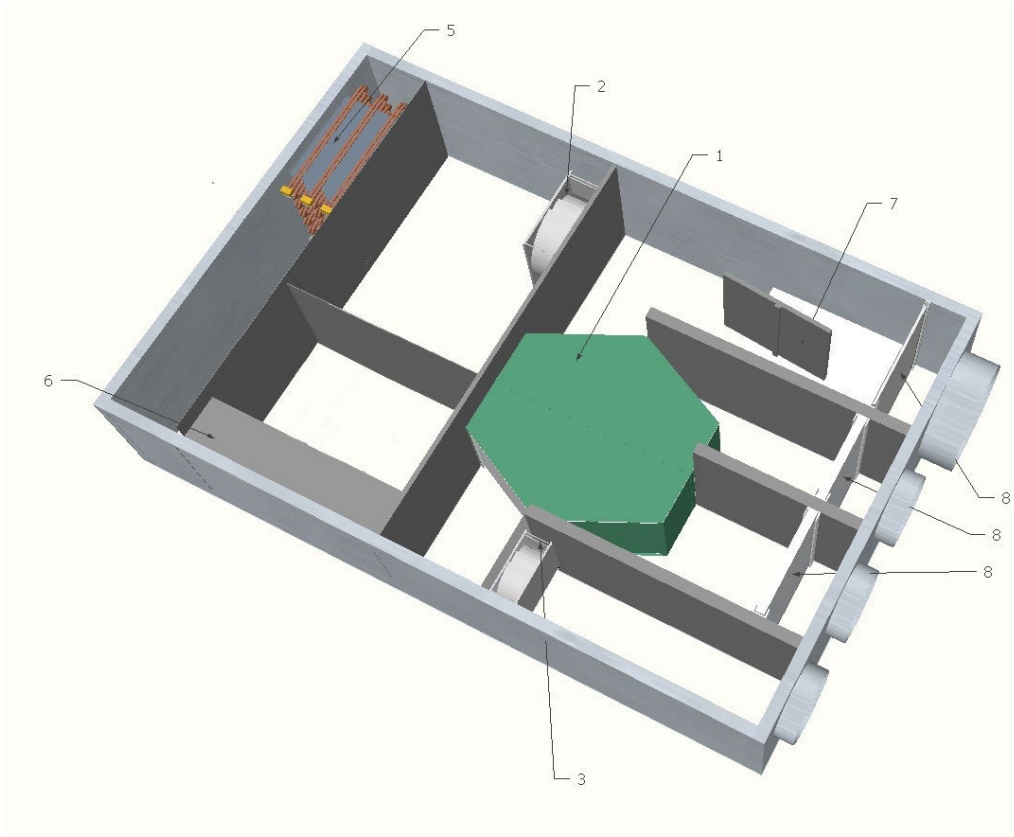

- 1. Heat recovery
- 2. Inlet fan
- 3. Exhaust fan

- 5. Finned batteries
- 6. Electrical cabinet
- 7. Recirculating air damper
- 8. Air filter

1.1.10 PACKAGING AND TRANSPORTATION

The units are supplied for transport secured on a wooden pallet and placed in cardboard boxes. For ease of movement, the units are equipped with a wooden pallet and hooks on the base that allow them to be lifted and positioned at the installation site. The unit may be stored in a weather-protected room with temperatures no lower than 0°C, up to a maximum of 40°C.

1.1.11 RECEIVING CONTROL AND HANDLING



The unit is shipped fully precharged with refrigerant gas in the circuits and with brine-free oil in the compressors. Under no circumstances may water be present in the hydraulic circuits, as the unit is thoroughly drained after testing. Upon arrival the customer is required to inspect the unit also in the internal areas to verify that it has not been damaged during transport; the unit has left the factory in perfect condition. If this is not the case, immediate recourse must be taken against the carrier by detailing the extent of the damage on the bill, producing photographic evidence of the apparent damage, and notifying the shipper of any apparent damage by registered mail with return receipt. The manufacturer assumes no responsibility for damage due to transportation even if he has provided the shipment himself. Great care should be taken when handling the units during unloading and positioning in place to avoid damage to the casing and more delicate internal components such as compressors, exchangers, etc. By all means, keep the unit in a horizontal position without tilting it. All indications about the precautions necessary to ensure that no damage is done to the unit, and an indication of the weight of the unit, are given on the packaging. The materials that make up the packaging may be of various kinds such as wood, cardboard or polyethylene (plastic). It is good practice to send them for disposal or recycling through specialized companies to reduce their environmental impact.

1.1.12 DISASSEMBLY AND DISPOSAL



Do not disassemble or dispose of the product yourself. Disassembly, demolition, disposal of the product shall be carried out by authorized personnel in accordance with local regulations.



2 INSTALLATION

2.1.1 CONDITION OF INSTALLING



The unit should be installed in accordance with national and local regulations governing the use of electrical devices and in accordance with the following directions:

- Install the unit inside residential buildings with an ambient temperature between 0°C and 45°C;
- Avoid areas near sources of heat, steam, flammable and/or explosive gases and particularly dusty areas;
- install the unit in a frost-free place (condensation water should be drained unfrozen, at a certain angle, using a siphon);
- Do not install the unit in areas with high relative humidity (such as bathroom or toilet) to avoid condensation on the outside surface;
- Choose an installation location where there is sufficient space around the unit for air duct connections and to be able to perform maintenance work;
- the texture of the ceiling/wall/floor where the unit will be installed must be adequate for the weight of the unit and not cause vibration.

In the room chosen for installation, there must be:

- air duct connections;
- 230V single-phase electrical connection;
- condensate drainage connection;
- hydraulic connection.

2.1.2 UNIT POSITIONING



Ceiling mounting

Mounting the unit to the ceiling requires:

- Place 4 threaded rods inside the prepared brackets on the 4 corners of the unit;
- Secure the unit to the ceiling, via the brackets, using suitable anchoring systems (dowels, chains...) and check its levelness by helping with a spirit level.
- Ensure sufficient space for carrying out maintenance activities: the opening of the unit cover (from below) must be guaranteed.

Do not mount the unit with the sides in direct contact with the walls to avoid possible contact noise, insert rubber or neoprene strips in that case.

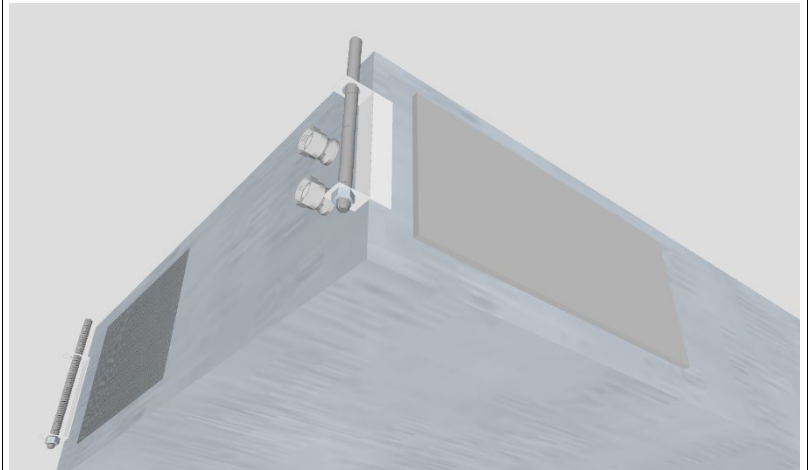

Ceiling mounting

Floor mounting

Mounting the unit to the floor requires:

- Place 4 threaded rods inside the prepared brackets on the 4 corners of the unit;
- Secure the unit to the floor by means of the brackets, using suitable anchoring systems (dowels, chains...) and check its levelness by helping with a spirit level.
- Ensure sufficient space for carrying out maintenance activities: opening the unit cover (from below) must be guaranteed.

Do not mount the unit with the sides in direct contact with the walls to avoid possible contact noise, insert, rubber or neoprene strips in that case.

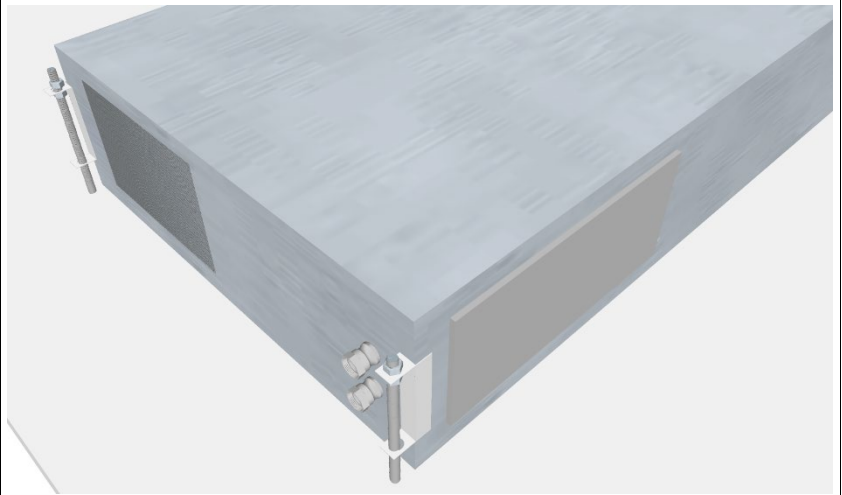

Floor mounting

CONDENSATE DRAIN CONNECTION



Because of the heat-recovery system (hot exhaust air is cooled by the supply air inside the heat exchanger), and the dehumidification coils, the moisture in the indoor air condenses inside the unit.

For proper operation of the heat recuperator, it is therefore necessary to connect two condensate drains to the plumbing (drain) of the house. In addition, in order to allow the condensate water to drain properly and avoid air suction, the condensate drains should be provided with special siphons to be supplied and installed by the installer;

Observe the following standards when installing the condensate drain:

- Slope of at least 2% at the outlet pipe;
- Provide the possibility of disconnecting the exhaust pipe for any maintenance (especially in case of ceiling installation);
- Make sure the discharge end of the pipe is at least below the water level of the siphon;
- Make sure the siphon complies with the following rules and is always full of water:

$$H1 > 40\text{mm} \quad H2 > 40\text{mm}$$

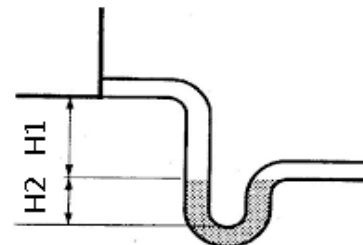
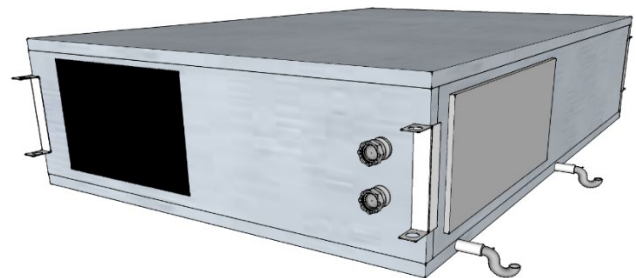

Condensate drain connection

3 AREALIC CONNECTIONS

3.1.1 AREALIC CONNECTIONS



The unit has 4 male circular rear connections of different \varnothing and a rectangular front port depending on the size; refer to the following diagram and stickers placed on the unit for proper air duct connection.

Table Diameters of aeraulic connections unit

Size	30/15	50/25	60/15	90/25
\varnothing Recirculation mm	160	200	200	250
\varnothing Stale air mm				
\varnothing Outside air mm	125	160	125	160
\varnothing Expulsion mm				
Input section mm	350x180	490x255	550x180	720x200

Installation of at least 500mm of flexible piping is recommended to avoid vibration drag and annoying noise from installation. Depending on the system in which the unit is to be installed, it will be possible to orient the four aeraulic connections appropriately. Below are the possible configurations:

VERSION CONFIGURATIONS

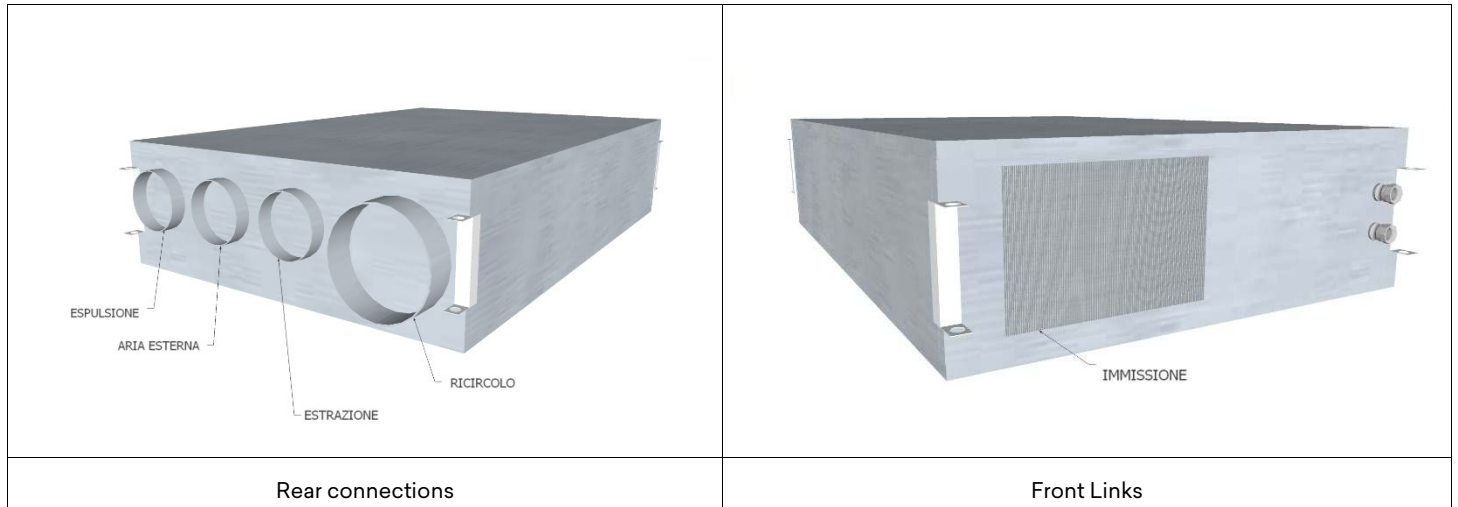

4 PLUMBING CONNECTIONS

4.1.1 GENERALITY



- The units are equipped with hydronic coils with water-air exchange;
- The connections on the units, even in different applications and versions, are always common to all units;
- Make sure to respect the flows indicated on the nameplates: inlet (inlet water to the unit), outlet (outlet water from the unit);
- Ensure that the weight of the piping does not bear on the connections provided;
- Provide shut-off valves on the supply and return piping to the system;
- All chilled water piping should be insulated to minimize unwanted heat exchange and condensation formation;
- Before backfilling the pipes, make sure that the pipes do not contain any foreign materials: such as sand, stones, rust flakes, welding drops, slag, etc. If not, carry out a flushing of the hydraulic circuit by-passing the unit;
- Absolutely avoid pump cavitation and the consequent presence of air in the hydraulic circuit.

Chemical and physical characteristics of water

Incompatible chemical and physical characteristics could affect the integrity of the hydraulic parts of the unit.

Check the characteristics of the water;

DESCRIPTION	Limit Value
Hardness	< 10°F
PH Value	7,5 / 9
Oxigen	< 2 mg / l
Conductivity	< 500 uS / cm
Iron	< 2 mg/l
Manganese	< 1 mg/l
Nitrate	< 70 mg/l
Sulfate	< 70 mg/l
Chlorine compounds	< 300 mg/l
Free Carbon Dioxide Radical	< 10 mg/l
Ammonium	< 20 mg/l

4.1.2 POSITIONING AND PROCEDURES OF CONNECTIONS

Hydraulic connections are located on the side of the unit;

The connections are with female threads;
Respect IN as water inlet to the unit and OUT as water outlet from the unit

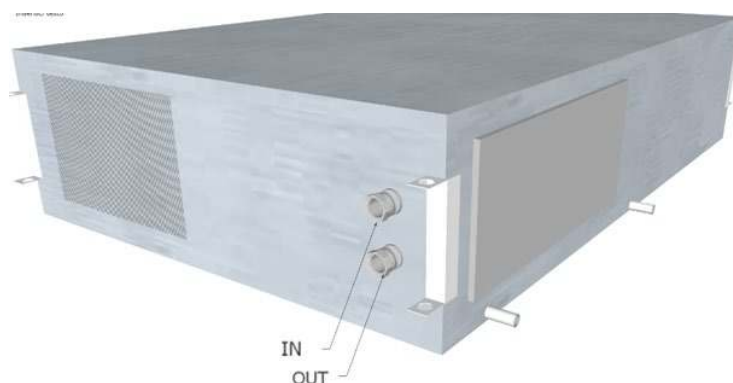

Connect piping with threaded female fitting, and tighten it with dedicated tools;

Be careful not to rotate or twist the atubations from inside the unit;

Making the piping rotate during aconnection could damage the aconnections inside the unit and have water leakage in operation;

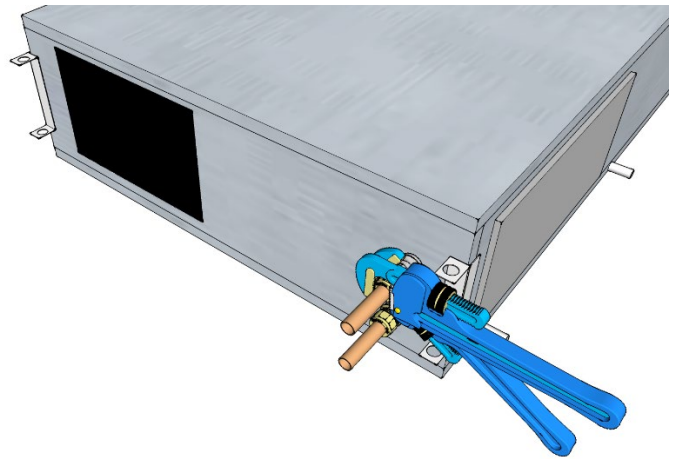

4.1.3 2-3 WAY VALVE CONNECTION

Connections of optional 2 / 3-way valves are to be made as indicated;

Be careful to observe the markings placed on the valve :

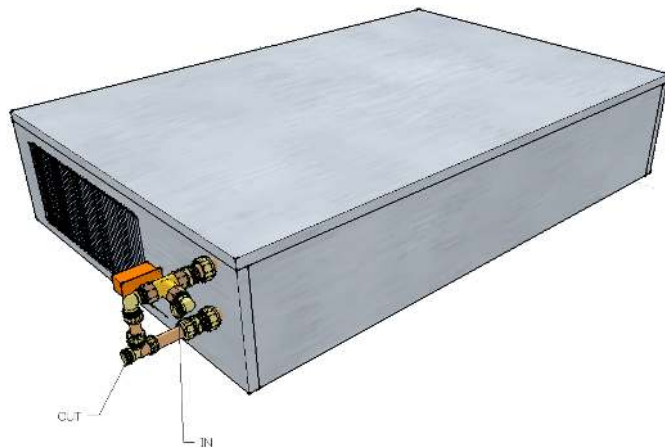

5 ELECTRICAL CONNECTIONS

5.1.1 GENERALITY



- Before starting any operation to make the electrical connection, make sure that the unit is not electrically powered;
- Make the necessary electrical connections by consulting only the wiring diagram attached to this manual;
- Install a suitable circuit breaker and differential protection device to serve the unit only;
- It is essential that the unit be connected to a grounded outlet;
- Check that the electrical components chosen for the installation (main circuit breaker, circuit breakers, cable cross-section and terminals) are suitable for the electrical rating of the installed unit and that they take into account the compressor inrush currents as well as the maximum load that can be reached. The relevant data are shown on the attached wiring diagram and on the unit nameplate;
- It is forbidden to enter the unit with electrical cables except where specified in this booklet;
- Use electrical cables and conductors of suitable cross-sections and complying with the current regulations of the various countries;
- Absolutely avoid running electrical cables in direct contact with piping or components inside the unit;
- Check after the first moments of operation that the screws of the power terminals are tightened.

Table for power line sizing

SIZE		30/15	50/25	60/15	90/25
Power supply	V/Ph/Hz	230/1/50			
Max absorbed current	A	0,9	1,6	1,8	2,2

5.1.2 PLACEMENT AND PROCEDURES OF LINKS

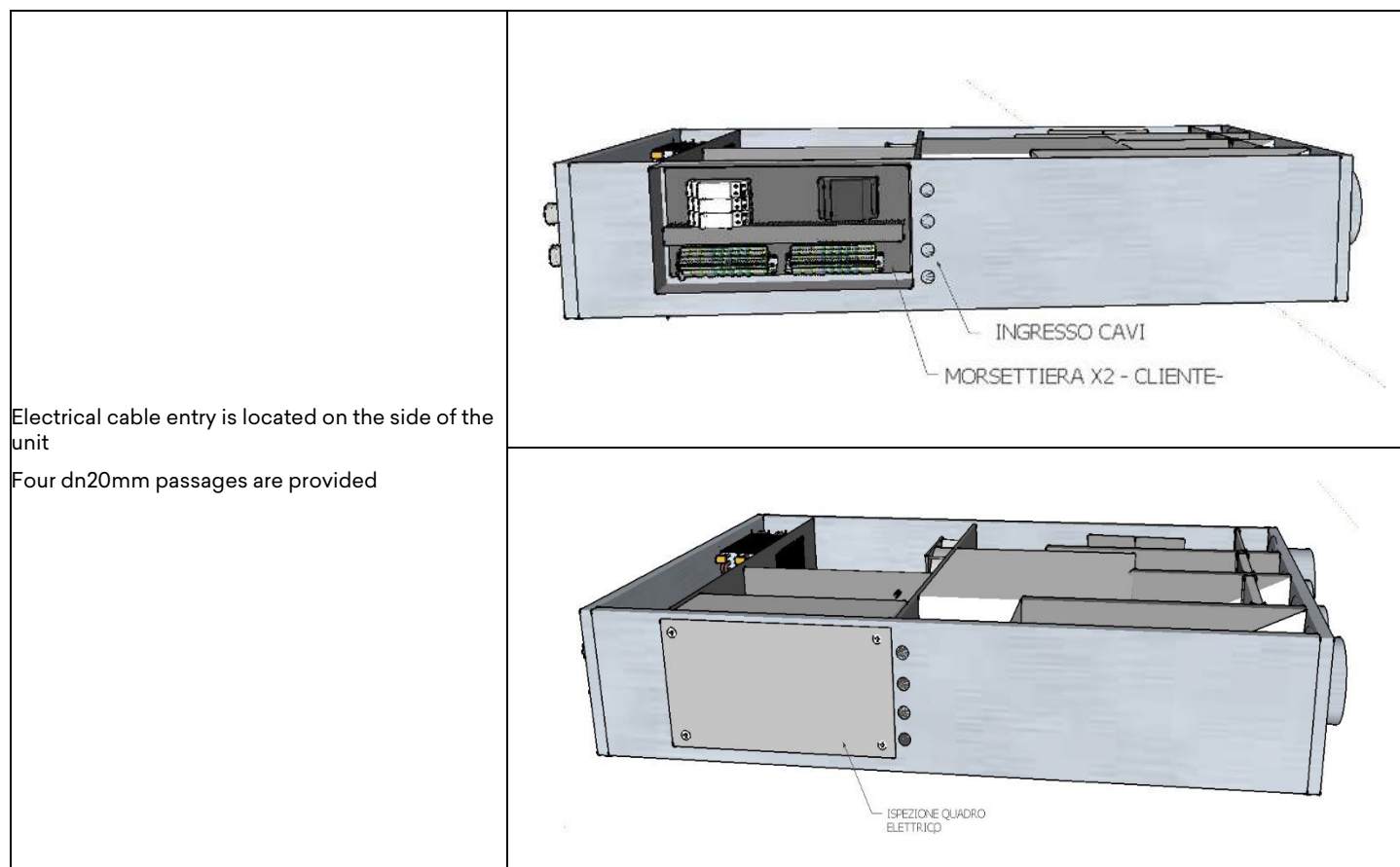

5.1.3 UNIT WIRING DIAGRAMS

VERSION -I-

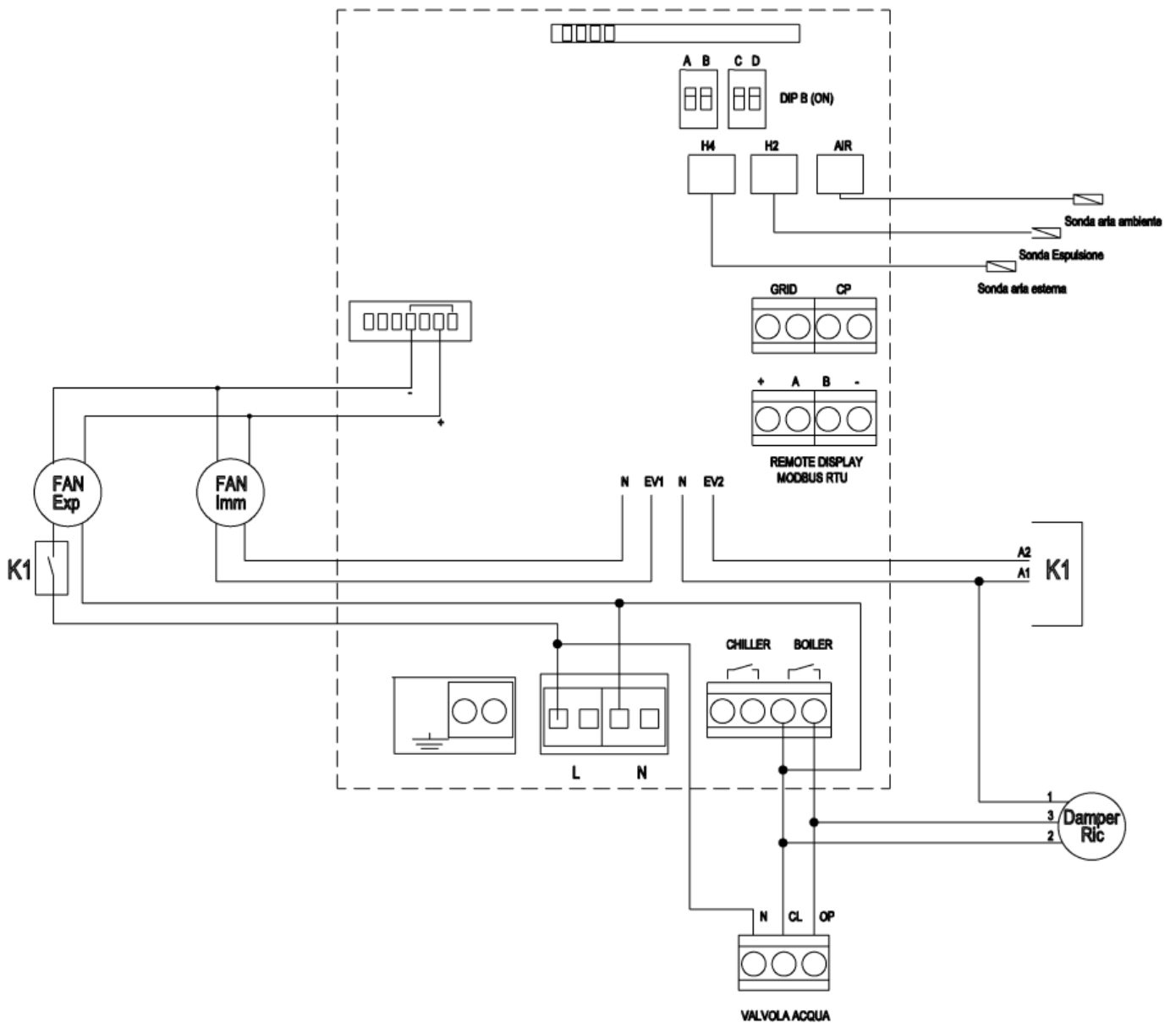

CONNECTIONS BY CLIENT

CONNECTIONS BY CLIENT		
GRID	Humidistat / Air quality controller	Closed contact / active function
CHILLER	Chiller / Generator Activation	Contact Clean (hot/cold request activation)
N - CL - CP	Water valve / post battery	Voltage contact (220v)
REMOTE DISPLAY	Remote control (4 wires)	
ON OFF REMOTO (SU DISPLAY)	ON OFF remote contact present on remote display	Contact closed / unit OFF



Remote panel connection complete with air quality, humidity and temperature probe

The -I- version board provides capacitive touch-type remote controls for managing all functions of the unit and prepared for wall installation or external 502 box.

There are two families of remote commands:

- Serial command with the possibility of RS485 Modbus RTU connection;
- Serial command with the possibility of connection to a WIFI network and management of the unit through dedicated APP.

Controls can be supplied in either White or Black coloring.

The connection of the control to the unit is through a **0.75/1mm 4-core shielded/braided cable**.

The command provides, through the other available terminals, for connection to an RS485 Modbus RTU serial network as shown below.

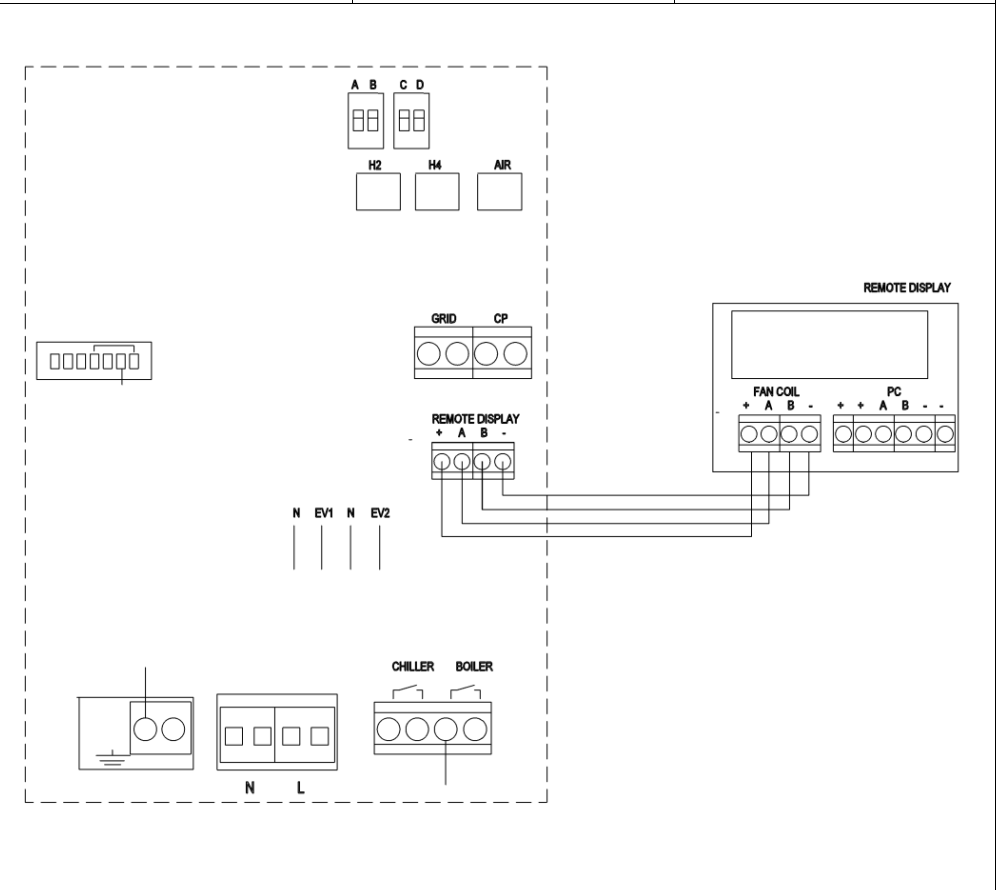

Pannello remoto

Auxiliary Connections

The board allows operation of the Brushless EC fan through a remote control described above; Some auxiliary functions have been implemented in the board, such as the connection of regulators and the management of a battery/post valve.

DISPLAY CONNECTION FOR MULTI-UNIT CONTROL

The panel provides for the control of multiple units; up to 30 units can be connected and will be managed by the one remote panel;

They will have to be connected in series with in and out connection on the individual unit boards;

The network is an RS485 network; Use shielded 2-wire cable with a maximum length of 150m;

-Make a route so as to minimize the length of the leads;

-Terminate the line with the 120 Ω resistor provided;

- Do not make "star" connections; -The connection with the RS485 cable is polarized.

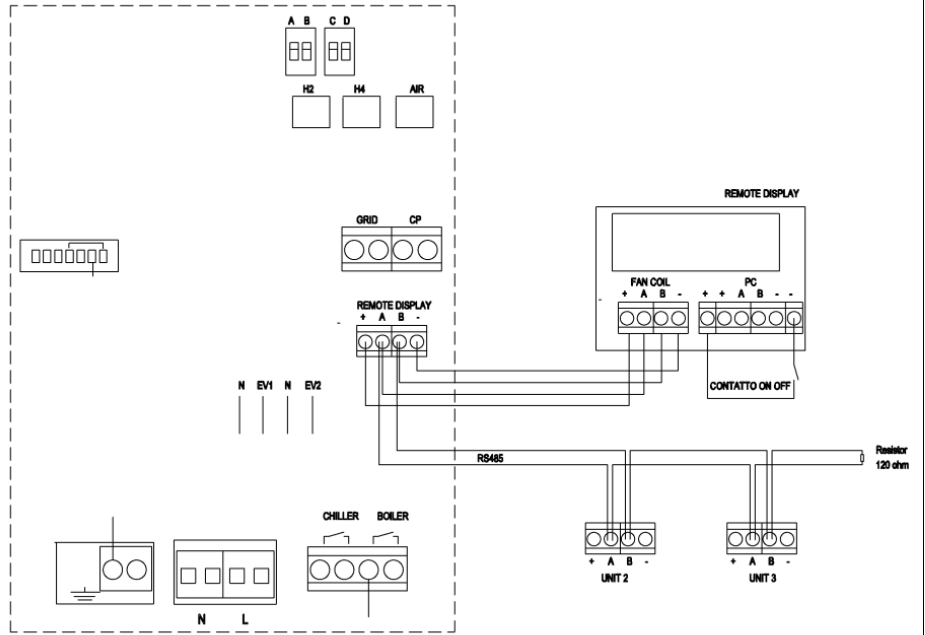

REMOTE ON-OFF CONNECTION

The remote panel provides an ON OFF control with which the unit can be connected via a dry contact to a device for remotely turning the unit on/off such as a switch or timer

The logic provides:

Closed contact : Unit OFF

Open contact : Unit ON

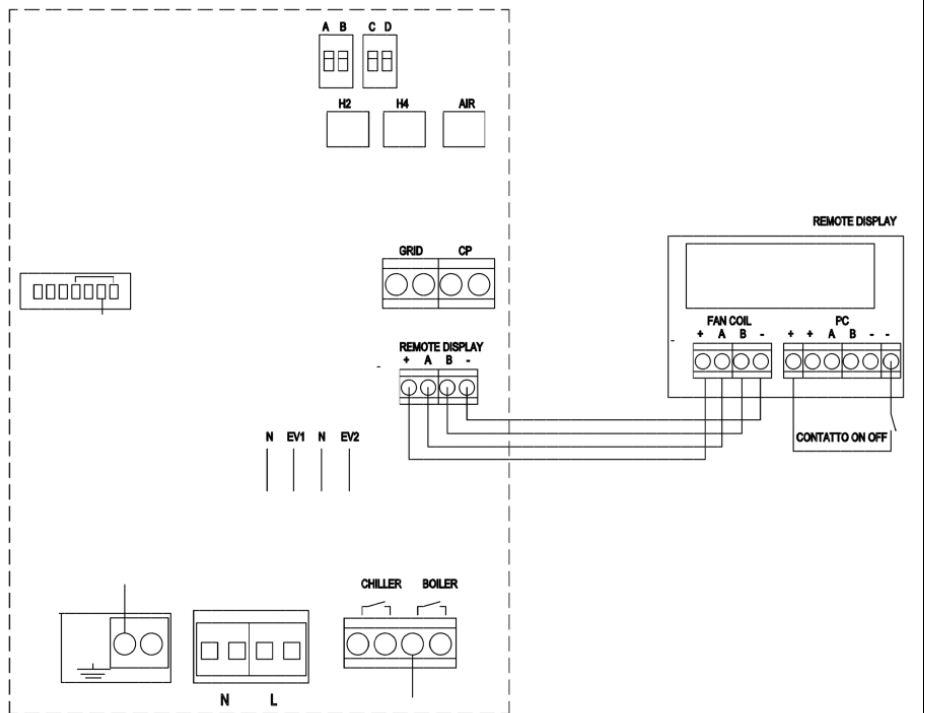

BOOSTER CONNECTION

Provision is made for connecting a contact that raises the ventilation speed to maximum speed;

The connection is made on the GRID terminals as shown on the wiring diagram

Contact closed - booster speed active



Booster



Booster connection

VALVE/POST BATTERY CONNECTION

The unit provides control of an electric post valve/battery, through the 230v control provided on the board;

- N- COMMON
- CL- FIXED VOLTAGE FOR 3-POINT VALVE CONTROL
- CP- VALVE ON-OFF CONTROL 2-3 POINTS

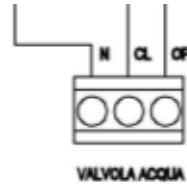

Water Valve / Post Battery Connection

GENERATOR / POST BATTERY / PRE-HEATING CONNECTION

The unit provides for the control of a generator that is activated in parallel with the post battery valve through the dry contact in the terminal block;

The contact can alternatively control a preheat coil, to be used for installation in particularly cold climates;

Pre or post function selection, can be done via dipswitch A and illustrated in the remote control functions.



Connecting Generator / Battery pre - post







5.1.5 OPERATION VERSION -I-

The unit is fully manually controlled by the user through the wall-mounted touch control;

The remote control includes the air quality and humidity sensor inside for automatic air flow control;



Remote Panel

Below are the keys in the main mask:	Meaning of the keys in the main display:			
		Allows the unit to be turned on/off from the keyboard		Key for changing the temperature set
		Keys for fan speed selection: Silent / nominal / maximum		Key for summer/winter selection
		Key for rated speed and sensor operation		ALLARM signal
Main mask key display				

5.1.6 SWITCHING THE UNIT ON AND OFF

- The unit can be enabled and disabled via the On / Off button on the display.



Power on / Power off unit

5.1.7 MOISTURE AND IAQ DISPLAY

The long press (3 sec) of the central fan button allows you to immediately show the humidity detected.

Press the same button again for 3 seconds to change to IAQ.

Wait 10 seconds without pressing any buttons to automatically exit from this menu and return to the main one.



Humidity set regulation

5.1.1 CHANGING FAN SPEEDS AND BOOSTER FUNCTION

-On the display are buttons for selecting the desired speed of the unit;
 Each time the speed is selected, after 1 second you have the actual fan speed change.
 -There are three selectable speeds:
 Night (minimum speed) - nominal (average speed) - maximum (maximum speed)
 The Booster command that becomes a priority over each speed, is managed through digital contact;



Fan speed management

5.1.2 NOMINAL SPEED FUNCTION

- By pressing the auto button, the unit will operate according to the demand setting of the humidity and air quality sensors according to the dipswitches settings made when starting the unit;

If the sensors are set the logics will be as follows:

-Sensor of the humidity:

-in winter the flow rate adjustment increases with the increase in humidity;

In this way the ambient humidity is controlled to have correct humidity in the environment;

-in summer the regulation is reverse and the flow rate decreases with the increase in internal humidity;

this is because in the summer the external absolute humidity contributes to the increase in the internal relative humidity;

-IAQ air quality sensor:

In both seasons the unit detects the air quality index; This numerical value ranges from 0 (excellent air quality) to 5 (very bad air quality). The sensor ranges are

- 0 to 1.99: Excellent air quality
- From 2 to 2.99: Good air quality
- 3 to 3.99: Average air quality; exposure to these values is not recommended for more than 12 months
- 4 to 4.99: Poor air quality; exposure to these values is not recommended for more than 1 month
- 5: Unacceptable air quality; exposure to these values is not recommended

The Recommended setting value that is set by default is 2.5

The modification of this parameter is available only in the installer menu, accessible by authorized personnel.



AUTO Function

5.1.3 SEASON CHANGE

- the season change on version I must be done by keyboard;
 Press and hold the season switch button for at least 3 seconds to change the season status;
 The operation must be carried out to activate the correct logic:
 In winter the antifreeze function and in summer the bypass function;
 Logic symbols: SUN – WINTER SNOWFLAKE - SUMMER



Season change

5.1.4 KEY LOCK

By pressing the + and - keys simultaneously for 3 seconds the local lock of all keys is activated, confirmation is given by the display of the words bl. All adjustments are inhibited to the user and when pressing any button bl appears. Repeating the sequence you get the release of the keys.



Key lock

5.1.5 ADJUSTMENT OF PANEL BRIGHTNESS

With the panel off, press and hold the + button for 5 seconds until the word 01 appears. With the button - bring the value to 00 and wait for 20 seconds to verify the correct setting.

0/0

Brightness adjustment

5.1.6 SET POINT TEMPERATURA PER CONTROLLO BATTERIA DI POST

-The temperature set point is achieved by pressing the + and - buttons;
The panel always shows the temperature detected, at the press of one of the two buttons next, the set point of temperature set is shown immediately and you can change the value of Set temperature;



Temperature set regulation

5.1.7 SET POINT IAQ AIR QUALITY REGULATING AIR FLOW AUTO

The set point of humidity occurs through the prolonged pressure (3sec) of the central fan button;
The panel immediately shows the humidity detected, at the press of one of the two keys + and - , the set point of humidity set is shown immediately and you can change the value of Set humidity;
Wait 10 seconds without pressing any buttons to automatically exit from this menu and return to the main one.



Humidity set regulation

6 MAINTENANCE

In order to always ensure the correct and optimal operation of the unit, it is necessary to periodically perform all maintenance interventions..

6.1.1 CLEANING OR REPLACING FILTER

To replace or clean the filters, do the following:

- turn off the power to the unit;
- open the filter covers through the dedicated knobs;
- Remove dirty filters;
- insert new filters gently;
- close the lid with the dedicated knobs.

If the filter conditions allow, they can be cleaned using a vacuum cleaner or low pressure compressor.

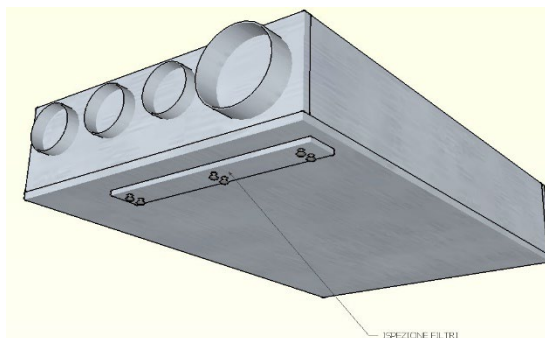

View for filter extraction

6.1.2 HEAT EXCHANGER CLEANING

It is advisable to verify the status of the heat exchanger at each cleaning/change of filters and to proceed to its cleaning if deemed appropriate. This operation must be carried out only by qualified personnel (installer).

To clean the heat exchanger proceed as follows:

- remove power to the unit;
- in case of ceiling installation, disconnect the condensate drain pipe;
- open the cover of the unit by unlocking the fastening hooks and removing the screws;
- extract the heat exchanger using the special green band/strap;
- proceed to the cleaning very gently using a vacuum cleaner or a low pressure compressor (to prevent dirt from entering the heat exchanger, clean in the opposite direction to that of the air flow);
- insert the exchanger back in place;
- close the lid by locking it in place by locking the fastening hooks and inserting the screws.

Attention! Never touch the fins of the exchanger, handle the exchanger holding it only on the closed sides.

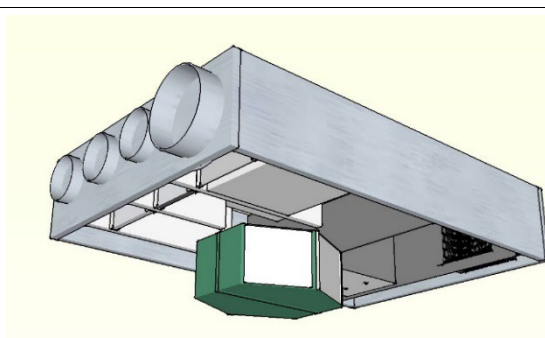
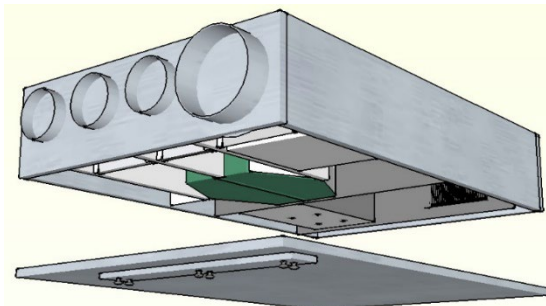

View for heat exchanger extraction

6.1.3 GENERALE CLEANING OF THE UNIT

It is advisable to periodically check and clean the fans, the condensate drain and the internal walls of the unit. These operations must be carried out only by qualified personnel (installer).

To carry out the above operations do the following:

cut off power to the unit

- in case of ceiling installation, disconnect the condensate drain pipe;
- open the cover of the unit by unlocking the fixing hooks on it;
- check and if necessary clean the fans, condensate drain and walls;
- close the cover by locking it with the fixing hooks on the unit;
- Connect the power cord and turn on the unit from the switch on the side panel.

For cleaning you can use a vacuum cleaner, a rag slightly moistened with water, a soft bristle brush or a low pressure compressor.

Attention! On the blades there are small metal clips for balancing the blades themselves, DO NOT remove them.

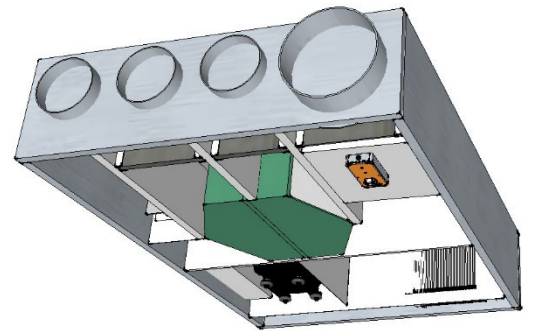

Unit views for general cleaning

7.1.1 GENERALITY

In case of problems or failures, take note of any error code that appears on the display of the electronic control unit or the remote control, take note of the model and the serial number of the unit you have (on the identification plate attached to the side of the unit) and contact the installer.

7.1.2 PROBLEMS WITHOUT DISPLAY ERROR INDICATION



PROBLEM	CAUSE	REMEDY
Display OFF	No power (light switch off)	Check the connection to the power supply Check and replace the fuse on the (black) power connector on the side of the unit.
Low or no air flow The premises remain moist	Clogged filters	Replace the filters
	Clogged exchanger	Clean the exchanger
	Ice exchanger	Bring the heat exchanger to a warm place and wait for it to thaw, do not heat with direct heat sources.
	Dirty fan	Clean the fan
	Clogged fan ducts	Cleaning the ventilation ducts
	Outside temperature below 0 °C	The unit may be in antifreeze mode, wait until the outside temperature rises or provide for the installation of an electric pre-heating heater.
Hight noise	Noise from the unit	Check for cracks and/or air leaks from the unit panels Check the connection of the siphon Check whether engines are running correctly (bearings)
	Noise from ducts	Check for cracks in the intake ducts / intake/ ejection
Hight vibrations	Vibrating panels	Verify the integrity of the unit's aluminum panels and profiles Check that the lid of the unit and the panel covering the electronic board are properly closed Check that there are no walls that can transmit vibrations to the wall / floor / countertops
	Fan blades not in balance	Check the integrity of the blades Clean the fans Check that the fans still have small metal clips for balancing the blades
Condensation loss	Clogged condensate drain	Cleaning the condensate drain
	Condensation does not flow from the exhaust pipe into the collection tray	Check that the unit is perfectly flat Check that the condensate drain connections are clogged

7.1.3 ALARM WARNING

Below is a list of all alarms managed by the application.

The presence of an alarm has two display modes:

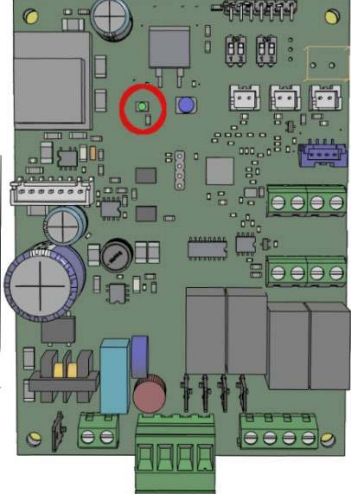
- an error code on the command;
- an LED on the electronic board showing a flashing sequence with alarm type present.

	
1 LED ALARM SIGNAL UNIT CARD	2 PANEL ALARM SIGNAL

7.1.4 ALARM TABLE DISPLAYED - VERSION I -

Below is the table of malfunctions of the signalled unit, in electronic versions I from the remote display or from the flashing of the LED on the board.

CODE	DESCRIPTION	CAUSE	REMEDY	FLASHES SCHEDULE
E1	Alarm Probe shooting AIR	Probe failure or failure to read	Check the probe connection or replace it	1 flashes – off 3 second
	Fan alarm	Faulty fan connector or no feedback signal	Check the connection of the fan connector to the board Replace the fan control cable	2 flashes – off 3 second
	Alarm Expulsion probe H2	Probe failure or failure to read	Check the probe connection or replace it	3 flashes – off 3 second
	Alarm External air probe H4	Probe failure or failure to read	Check the probe connection or replace it	5 flashes – off 3 second
	Alarm connection with remote display	Error connecting the remote display	Check the electrical connections Verify that A and B are not reversed Verify the correct insertion of the display connection card on the main card	Led Off
	Alarm communication with remote display	No communication between display and card for at least 300 seconds.	Check the status of the filter and press and hold the on off button to reset the signal; Verify that A and B are not reversed Verify the correct insertion of the display connection card on the main card	6 flashes – off 3 second

