

INSIGNIA™

USER GUIDE

115-Can Beverage Cooler

NS-BC115SS9/NS-BC115SS9-C



Before using your new product, please read these instructions to prevent any damage.

Contents

Introduction	3
IMPORTANT SAFETY INSTRUCTIONS	3
Features	5
Package contents	5
Components	6
Control and display panel	7
Setting up your beverage cooler	7
Before using your cooler	7
Finding a suitable location	7
Leveling your cooler	8
Reversing the door	8
Grounding requirement	11
Connecting to power	11
Using your beverage cooler	11
Turning on your cooler	11
Setting the temperature	12
Memory function	12
Using the display	12
Lighting your cooler	12
Using the adjustable shelves	12
Arranging your beverages	12
Maintaining your beverage cooler	13
Cleaning the interior of your cooler	13
Defrosting your cooler	13
Storing your cooler	13
Moving your beverage cooler	14
Tips on saving energy	14
Troubleshooting	14
Error codes	14
Specifications	15
ONE-YEAR LIMITED WARRANTY	16

Introduction

Congratulations on your purchase of a high-quality Insignia product. Your NS-BC115SS9/NS-BC115SS9-C represents the state of the art in beverage cooler design and is designed for reliable and trouble-free performance.

IMPORTANT SAFETY INSTRUCTIONS



This symbol indicates that dangerous voltage constituting a risk of electric shock is present within your cooler.



This symbol indicates that there are important operating and maintenance instructions in the literature accompanying your cooler.

WARNING

- 1 Read these instructions.
- 2 Keep these instructions.
- 3 Heed all warnings.
- 4 Follow all instructions.
- 5 Do not use this appliance near water.
- 6 Clean only with a damp cloth.
- 7 Do not block any ventilation openings. Install in accordance with the manufacturer's instructions.
- 8 Do not install near any heat sources such as radiators, heat registers, stoves, or other apparatuses (including amplifiers) that produce heat.
- 9 Do not defeat the safety purpose of the polarized or grounding-type plug. A polarized plug has two blades with one wider than the other. A grounding type plug has two blades and a third grounding prong. The wide blade or the third prong are provided for your safety. If the provided plug does not fit into your outlet, consult an electrician for replacement of the obsolete outlet.
- 10 Protect the power cord from being walked on or pinched, particularly at plugs, convenience receptacles, and the point where they exit from the appliance.
- 11 Do not use extension cords or ungrounded (two-prong) adapters.

- 12 Unplug this appliance during lightning storms or when it will not be used for long periods of time.
- 13 Make sure that the available AC power matches the voltage requirements of this appliance.
- 14 Do not handle the plug with wet hands. This could result in an electric shock.
- 15 Unplug the power cord by holding the plug, never by pulling the cord.
- 16 Do not turn the appliance on or off by plugging or unplugging the power cord.
- 17 Turn off the appliance before unplugging it.
- 18 Refer all servicing to qualified service personnel. Servicing is required when the appliance has been damaged in any way, such as when the power-supply cord or plug is damaged, when liquid has been spilled or objects have fallen into the appliance, or when the appliance has been exposed to rain or moisture, does not operate normally, or has been dropped.
- 19 To reduce the risk of fire or electric shock, do not expose this appliance to rain, moisture, dripping, or splashing, and do not place objects filled with liquids on top of it.



WARNING

Electric Shock Hazard

Failure to follow these instructions can result in electric shock, fire, or death.

- 1 **WARNING**—Keep ventilation openings in the appliance enclosure or in the built-in structure clear of obstruction.
- 2 **WARNING**—Do not touch the interior of the chiller compartment with wet hands. This could result in frost bite.
- 3 **WARNING**—Do not use mechanical devices or other means to accelerate the defrosting process, other than those recommended by the manufacturer.
- 4 **WARNING**—Do not damage the refrigerant circuit when handling, moving, or using the cooler.
- 5 **WARNING**—Do not use electrical appliances inside the storage compartment of the appliance, unless they are of the type recommended by the manufacturer.
- 6 **WARNING—DANGER**—Never allow children to play with, operate, or crawl inside the cooler.
Risk of child entrapment. Before you throw away your old cooler:
 - 1) Take off the door
 - 2) Leave the shelves in place so that children may not easily climb inside
- 7 Unplug the cooler before carrying out user maintenance on it.



- 8 This appliance is not intended for use by persons (including children) with reduced physical, sensory, or mental capabilities, or lack of experience and knowledge, unless they have been given supervision or instruction concerning use of the appliance by a person responsible for their safety. Children should be supervised to ensure that they do not play with the appliance.
- 9 If a component part is damaged, it must be replaced by the manufacturer, its service agent, or similar qualified persons in order to avoid a hazard.
- 10 Dispose of the cooler according to local regulations as the cooler contains flammable gas and refrigerant.
- 11 Follow local regulations regarding disposal of the cooler due to flammable refrigerant and gas. All refrigeration products contain refrigerants, which under the guidelines of federal law must be removed before disposal. It is the consumer's responsibility to comply with federal and local regulations when disposing of this product.
- 12 This cooler is intended to be used in household and similar environments.
- 13 Do not store or use gasoline or any flammable liquids inside or in the vicinity of this cooler.
- 14 Do not use extension cords or ungrounded (two prong) adapters with this cooler. If the power cord is too short, have a qualified electrician install an outlet near the cooler.
- 15 If the supply cord is damaged, it must be replaced by the manufacturer, its service agent, or a similarly qualified person in order to avoid a hazard.

Features

- 115-Can capacity
- Temperature range from 34° to 50° F (1° to 10° C)*
- Auto-defrosting fan to eliminate ice and condensation build-up
- Touch controls and LED display
- Interior white LED light
- Reversible door
- Removable shelves

*Interior cooler temperature may vary up to 4°F from displayed temperature.

Package contents



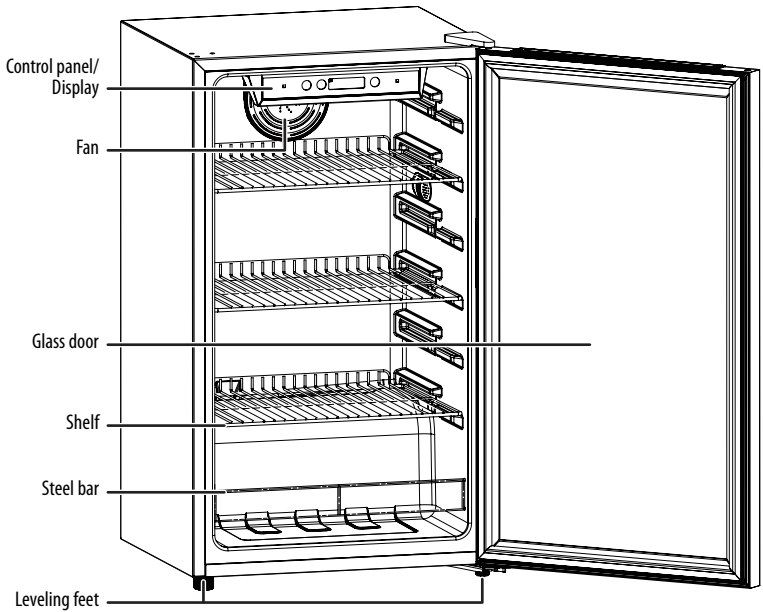

- 115-Can beverage cooler
- *Quick Setup Guide*

Components

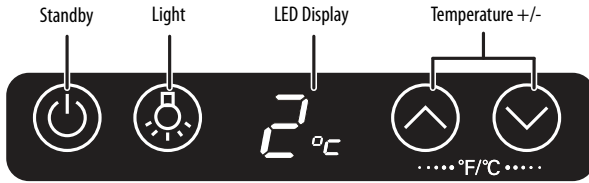

Control and display panel



BUTTON	FUNCTION
	<ul style="list-style-type: none"> • Press to turn the power on or off. • Hold for three seconds to set your cooler to “Standby” mode.
	Press to turn the interior light on or off.
	Press to increase the temperature by one degree.
	Press to decrease the temperature by one degree.
	Press both buttons simultaneously to change the display from F° to C° or back again.

Notes:

- Touch the control panel lightly when pressing the keys.
- To avoid scratching the control panel, do not touch it with sharp objects.

Setting up your beverage cooler

Before using your cooler

- Remove the exterior and interior packaging.
- Let the cooler stand upright for approximately half an hour before connecting it to power. This reduces the possibility of a malfunction in the cooling system from improper handling during transportation.
- Clean the interior surface with a damp, warm cloth.

Finding a suitable location

- This cooler is designed to be free standing only, and it should not be recessed or built into a countertop or wall.
- Place your cooler on a floor, counter top, or cabinet that is strong enough to support the cooler when it is fully loaded.
- Allow 1.6 in. (4 cm) of space on all sides of the cooler to allow for proper air ventilation.

- Place the cooler away from direct sunlight and sources of heat (stove, heater, radiator, etc.). Direct sunlight may affect the acrylic coating and heat sources may increase electrical consumption. Ambient temperature below 50°F (10°C) or above 85°F (29.4 °C) will hinder the performance of this cooler. This cooler is not designed for use in a garage or any other outside location.
- Avoid placing the cooler in moist areas.
- This unit is not designed to be installed in an RV or used with an inverter.
- Do not stack your cooler.
- For your cooler to operate normally, avoid placing it in areas with high magnetic fields or high humidity.

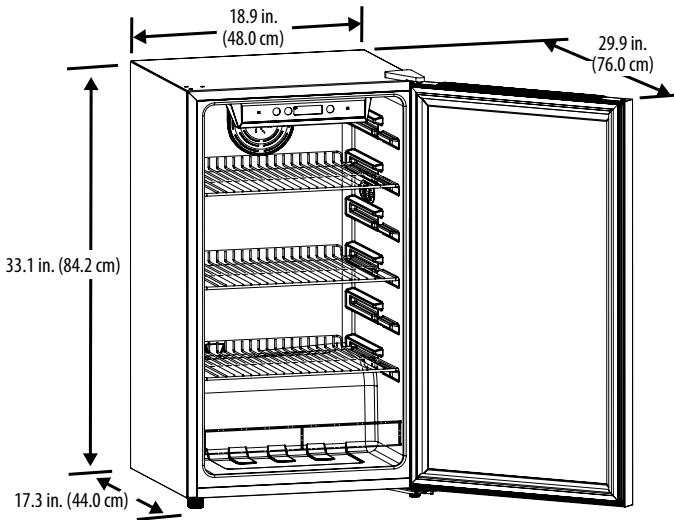

Leveling your cooler

- It is very important for the cooler to be level in order to function properly. If the cooler is not leveled during installation, the door may not close or seal properly, causing cooling, frost, or moisture problems.
- To level your cooler, you may turn either leveling foot clockwise to raise that side of the cooler or turn it counter-clockwise to lower that side.

Reversing the door

You will need a 10 mm socket wrench and a Phillips screwdriver. Have someone available to assist you in the process. Make sure that you keep all of the parts you remove to reuse them later.

CAUTION: Do not lay the wine cooler completely flat as that could damage the coolant system.

- 1 Make sure that your wine cooler is unplugged and empty.
- 2 Adjust the leveling feet to their highest position.
- 3 Use a blade to remove the rivets.

- 4 Use a blade to remove the hinge cover, then use a Phillips screwdriver to remove the hinge bolts.
- 5 Remove the upper hinge.

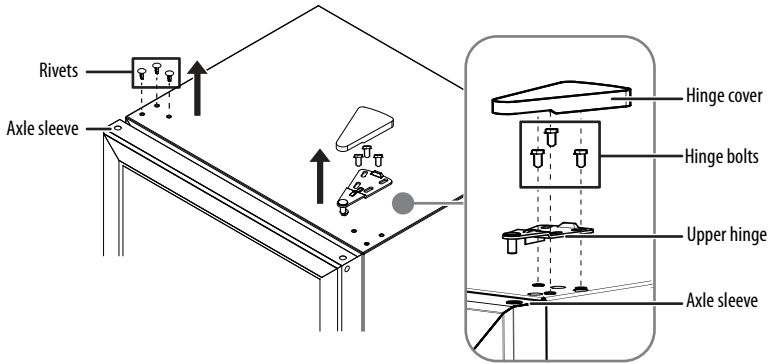

- 6 Remove the door from the wine cooler.

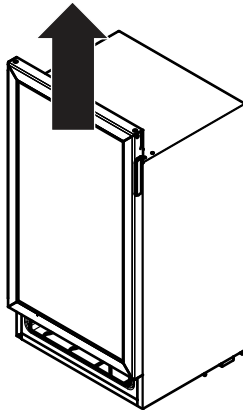

- 7 Use a Phillips screwdriver to remove the door stopper screws, then remove the door stopper.

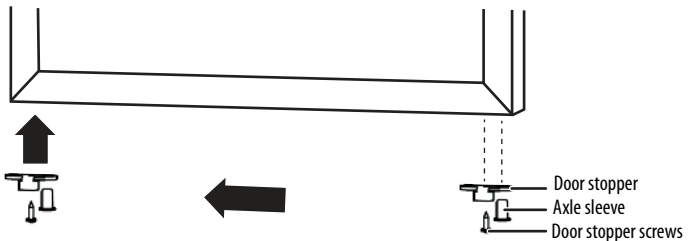

- 8 Use a Phillips screwdriver to remove the hinge bolts, then remove the lower hinge and the leveling foot.

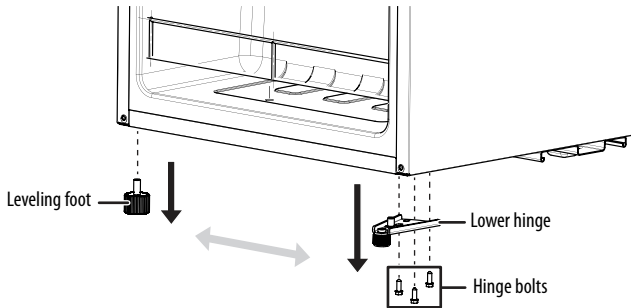

- 9 Attach the lower hinge and leveling feet to the opposite sides of the wine cooler.

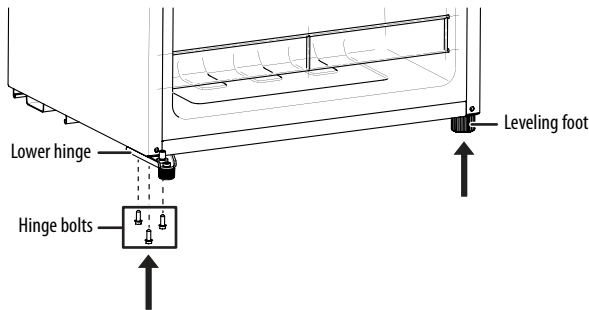

- 10 Replace the glass door, then reinstall the upper hinge. Make sure that you align the door and check the tightness of the door gasket.

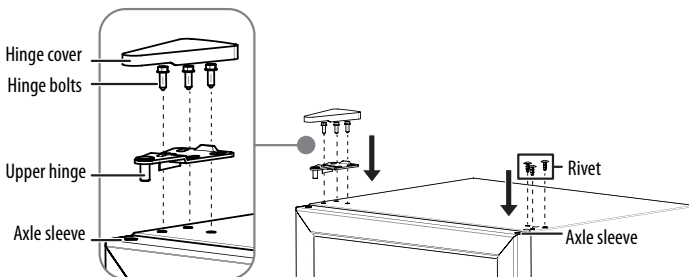

- 11 Adjust the leveling feet to level the cooler.

Grounding requirement

This cooler must be grounded. This cooler is equipped with a cord having a grounding wire with a grounding plug. The plug must be inserted into an outlet that is properly installed and grounded.

Consult a qualified electrician or service person if the grounding instructions are not completely understood, or if doubt exists as to whether the cooler is properly grounded.

WARNINGS:

- Improper use of the grounding plug can result in a risk of electric shock.
- Do not, under any circumstances, cut or remove the third ground prong from the supplied power cord.

Connecting to power

- Plug the appliance into a dedicated, properly installed grounded wall outlet. This appliance should be operated on a separate electrical circuit from other operating appliances.

CAUTION: This unit is not designed to be installed in an RV or used with an inverter.

- Plug in and run your cooler for three to four hours before making any temperature adjustments and before adding beverages. This allows your cooler to reach a stable temperature.

Notes:

- Check your local power source. This cooler requires a 110V-120V, 60 Hz power supply.
- Use a receptacle that accepts the grounding prong. The power cord is equipped with a 3-prong (grounding) plug which plugs into a standard 3-prong (grounding) wall outlet to minimize the possibility of electric shock hazard from this cooler.
- To prolong the service life of the compressor, wait for at least five minutes before restarting the cooler after a power failure.

- Do not use an extension cord with this cooler. If the power cord is too short, have a qualified electrician install an outlet near the cooler. Use of an extension cord can negatively affect the cooler's performance.



Using your beverage cooler

Turning on your cooler

Press the  button to turn your cooler on. The display screen and indicators blink for three seconds and an audible beep is heard, then the compressor starts working.

You can manually set your unit to "Standby" mode by touching the  button for approximately three seconds, provided that the control keys are unlocked and no other setting is in effect (the display is not blinking). Repeating this action restarts the unit.

Setting the temperature

- Press the temperature up  or down  buttons to increase or decrease the temperature by one degree. The temperature range is 34–50° F (1–10° C).
- Press and hold the temperature up  and down  buttons at the same time for three seconds to switch between Fahrenheit and Celsius.

Notes:

- A large number of beverages will lower the cooling efficiency of the cooler.
- When you put several beverages in the cooler at one time, the temperature in the cooler may rise temporarily.
- Adjust the thermostat setting by one increment at a time. Allow several hours for the temperature to stabilize between adjustments.
- The screen display always shows the set temperature. When adjusting the temperature, the temperature display blinks to indicate that the temperature is being adjusted.

Memory function

If you experience a power outage, when your cooler is turned on again it resumes the same temperature that was set when the power went off.

Using the display

- When you plug in your cooler for the first time, the display screen turns on for three seconds and you hear a start-up tone.
- In normal mode, the display shows the set temperature.

Lighting your cooler

- Press the light button  to turn the interior light on and off.

Using the adjustable shelves

- All of the shelves have tabs to engage the cabinet on both sides.
- Any of the shelves can be removed to accommodate larger beverages.

To remove a shelf:

- 1 Remove all bottles from the shelves.
- 2 Lift the shelf upward and then gently pull out the shelf.

To replace a shelf:

- Place the sides of the shelf back onto the supporting guides of the cabinet and push back until the shelf tabs slide into place.

CAUTION: Make sure that the tabs are firmly engaged in the supporting guides before storing any beverages.

Arranging your beverages

In order to maintain good air circulation in the cooler, do not let the beverages touch the back of the cooler.

Maintaining your beverage cooler

Your cooler is designed for year-round use with only minimal cleaning and maintenance.

When you first receive it, wipe the cabinet with a mild detergent and warm water, then wipe dry with a dry cloth. Do this periodically to keep your cooler looking new.

CAUTION: To prevent damage to the finish, do not use:

- Gasoline, benzine, thinner, or other similar solvents.
- Abrasive cleaners.

Cleaning the interior of your cooler

- 1 Turn off the cooler and unplug it from the wall outlet.
- 2 Remove all beverages.
- 3 Wash the interior with a damp, warm cloth.

Note: It is recommended that you soak your cloth in a baking soda solution before washing the interior. Mix one quart of warm water and two tablespoons of backing soda.

- 4 Clean the door gasket (seal) so the door closes properly.
- 5 Dry the interior and exterior with a soft cloth.

Defrosting your cooler

The ice build-up on the inner back wall of your cooler will automatically be defrosted in a compressor-off cycle.

When you press the  button, the compressor and circulation fan stops running while defrosting is in process.

Defrost water will drain out of the cooler, passing through the drain outlet in the inner back wall into a drain pan located above the compressor. The water will evaporate from the drain pan on its own.

Storing your cooler

- 1 Turn off the cooler and unplug it from the wall outlet.
- 2 Remove all beverages.
- 3 Clean the cooler.
- 4 Leave the door open slightly to avoid possible formation of condensation, mold, or odor.

WARNING: Make sure that children do not have access to your beverage cooler. If the door accidentally closes while a child is inside your cooler, the child may suffocate.

Moving your beverage cooler

Note: Make sure that the cooler stays in the upright position during transportation.

- 1 Turn off the cooler and unplug it from the wall outlet.
- 2 Remove all beverages.
- 3 Securely tape down all loose items inside your cooler.
- 4 Tape the door shut.

Tips on saving energy

- Locate your cooler in the coolest area of the room, away from heat-producing appliances or heating ducts, and out of direct sunlight.
- Do not overload the cooler. It forces the compressor to run longer.
- Do not open the door too often, especially if the weather is very hot. Close the door as soon as possible to prevent cool air from escaping.
- Make sure that the door seals completely to keep your cooler running efficiently.
- Make sure that the appliance is sufficiently ventilated, with adequate air circulation behind it.

Troubleshooting

Error codes

If a fault is detected, the display shows one of the following codes:

- **E1:** Temperature sensor fault
- **E4:** Defrost sensor fault

If any of these error codes appears on the display, contact your local dealer or service center. Do not try to repair the cooler yourself.

PROBLEM	SOLUTION
The cooler does not operate.	<ul style="list-style-type: none"> • Make sure that the cooler is plugged in and that the plug is pushed completely into the outlet. • Check the house fuse/circuit breaker box and replace the fuse or reset the circuit breaker. • If a power failure occurs, the cooler turns off. Wait until the power is restored, then turn it on again.
The cooler door does not close completely.	<ul style="list-style-type: none"> • Adjust the shelf properly. • Clean the door gaskets. • Level the cooler with the leveling feet.
The cooler is not cold enough.	<ul style="list-style-type: none"> • Make sure that the door is closed properly. • Allow time for new beverages to cool, then check again. • Set the control to a colder setting.
The cooler makes unusual noises or vibrates.	<ul style="list-style-type: none"> • Level the cooler with the leveling feet. • Move the cooler out from the wall. • This is normal.

PROBLEM	SOLUTION
Moisture is building up in the interior of the cooler.	<ul style="list-style-type: none"> • Make sure that the door is closed properly. • Move the cooler to a dryer location.
The cooler turns on and off frequently.	<ul style="list-style-type: none"> • Make sure that your cooler is in a room that is 50–85 °F (10–29.4 °C) or place your cooler in a cooler location. • Make sure that the door is closed properly. • Clean the door gaskets. • Set the control to a colder setting.

Specifications

Dimensions (WxHxD)	33.1 × 18.9 × 17.3 in. (84.2 × 48.0 × 44.0 cm)
Weight	70.5 lbs. (32 kg)
Power requirements	115V~60Hz
Current	1.1 A
Ambient operating temperature	54–109°F (12–43°C)
Cooler temperature range	34–50°F (1–10°C) Note: Interior cooler temperature may vary up to 4°F from displayed temperature.
Power cord length	5.4 ft. (1.65 m)

ONE-YEAR LIMITED WARRANTY

Definitions:

The Distributor* of Insignia branded products warrants to you, the original purchaser of this new Insignia-branded product ("Product"), that the Product shall be free of defects in the original manufacturer of the material or workmanship for a period of one (1) year from the date of your purchase of the Product ("Warranty Period").

For this warranty to apply, your Product must be purchased in the United States or Canada from a Best Buy branded retail store or online at www.bestbuy.com or www.bestbuy.ca and is packaged with this warranty statement.

How long does the coverage last?

The Warranty Period lasts for 1 year (365 days) from the date you purchased the Product. Your purchase date is printed on the receipt you received with the Product.

What does this warranty cover?

During the Warranty Period, if the original manufacture of the material or workmanship of the Product is determined to be defective by an authorized Insignia repair center or store personnel, Insignia will (at its sole option): (1) repair the Product with new or rebuilt parts; or (2) replace the Product at no charge with new or rebuilt comparable products or parts. Products and parts replaced under this warranty become the property of Insignia and are not returned to you. If service of Products or parts are required after the Warranty Period expires, you must pay all labor and parts charges. This warranty lasts as long as you own your Insignia Product during the Warranty Period. Warranty coverage terminates if you sell or otherwise transfer the Product.

How to obtain warranty service?

If you purchased the Product at a Best Buy retail store location or from a Best Buy online website (www.bestbuy.com or www.bestbuy.ca), please take your original receipt and the Product to any Best Buy store. Make sure that you place the Product in its original packaging or packaging that provides the same amount of protection as the original packaging.

To obtain warranty service, in the United States call 1-888-BESTBUY or in Canada call 1-866-BESTBUY. Call agents may diagnose and correct the issue over the phone.

Where is the warranty valid?

This warranty is valid only in the United States and Canada at Best Buy branded retail stores or websites to the original purchaser of the product in the county where the original purchase was made.

What does the warranty not cover?

This warranty does not cover:

- Customer instruction/education
- Installation
- Set up adjustments
- Cosmetic damage
- Damage due to weather, lightning, and other acts of God, such as power surges
- Accidental damage
- Misuse
- Abuse
- Negligence
- Commercial purposes/use, including but not limited to use in a place of business or in communal areas of a multiple dwelling condominium or apartment complex, or otherwise used in a place of other than a private home.
- Modification of any part of the Product, including the antenna
- Display panel damaged by static (non-moving) images applied for lengthy periods (burn-in).
- Damage due to incorrect operation or maintenance

- Connection to an incorrect voltage or power supply
- Attempted repair by any person not authorized by Insignia to service the Product
- Products sold "as is" or "with all faults"
- Consumables, including but not limited to batteries (i.e. AA, AAA, C, etc.)
- Products where the factory applied serial number has been altered or removed
- Loss or Theft of this product or any part of the product
- Display panels containing up to three (3) pixel failures (dots that are dark or incorrectly illuminated) grouped in an area smaller than one tenth (1/10) of the display size or up to five (5) pixel failures throughout the display. (Pixel based displays may contain a limited number of pixels that may not function normally.)
- Failures or Damage caused by any contact including but not limited to liquids, gels or pastes.

REPAIR REPLACEMENT AS PROVIDED UNDER THIS WARRANTY IS YOUR EXCLUSIVE REMEDY FOR BREACH OF WARRANTY. INSIGNIA SHALL NOT BE LIABLE FOR ANY INCIDENTAL OR CONSEQUENTIAL DAMAGES FOR THE BREACH OF ANY EXPRESS OR IMPLIED WARRANTY ON THIS PRODUCT, INCLUDING, BUT NOT LIMITED TO, LOST DATA, LOSS OF USE OF YOUR PRODUCT, LOST BUSINESS OR LOST PROFITS. INSIGNIA PRODUCTS MAKES NO OTHER EXPRESS WARRANTIES WITH RESPECT TO THE PRODUCT, ALL EXPRESS AND IMPLIED WARRANTIES FOR THE PRODUCT, INCLUDING BUT NOT LIMITED TO ANY IMPLIED WARRANTIES OF AND CONDITIONS OF MERCHANTABILITY AND FITNESS FOR A PARTICULAR PURPOSE, ARE LIMITED IN DURATION TO THE WARRANTY PERIOD SET FORTH ABOVE AND NO WARRANTIES, WHETHER EXPRESS OR IMPLIED, WILL APPLY AFTER THE WARRANTY PERIOD. SOME STATES, PROVINCES AND JURISDICTIONS DO NOT ALLOW LIMITATIONS ON HOW LONG AN IMPLIED WARRANTY LASTS, SO THE ABOVE LIMITATION MAY NOT APPLY TO YOU. THIS WARRANTY GIVES YOU SPECIFIC LEGAL RIGHTS, AND YOU MAY ALSO HAVE OTHER RIGHTS, WHICH VARY FROM STATE TO STATE OR PROVINCE TO PROVINCE.

Contact Insignia:

1-877-467-4289

www.insigniaproducts.com

INSIGNIA is a trademark of Best Buy and its affiliated companies.

*Distributed by Best Buy Purchasing, LLC

7601 Penn Ave South, Richfield, MN 55423 U.S.A.

©2018 Best Buy. All rights reserved.

Made in China

INSIGNIA®

www.insigniaproducts.com

1-877-467-4289 (U.S. and Canada) or 01-800-926-3000 (Mexico)

INSIGNIA is a trademark of Best Buy and its affiliated companies.

Distributed by Best Buy Purchasing, LLC

7601 Penn Ave South, Richfield, MN 55423 U.S.A.

©2018 Best Buy. All rights reserved.

Made in China

V1 ENGLISH
18-0077