

get started

**INSTANT® INFUSION BREW PLUS
12-CUP COFFEE MAKER**

USER MANUAL

Instant

Welcome

to your new Instant® Infusion Brew Plus 12-Cup Coffee Maker!

Brew delicious, smooth coffee anytime you crave it, with maximum flavor and customization in every cup. Here are some helpful resources as you get to know your new Instant® appliance.

Get started with your Infusion Brew Plus!



CONTENTS

Important safeguards	2
Whats in the box	5
Using your Instant® Infusion Brew Plus	6
Initial setup	7
Brewing coffee	11
Care, cleaning and storage	16
Troubleshooting	18
Learn more	20
Warranty	21

IMPORTANT SAFEGUARDS

⚠️ WARNING

At Instant, we want you to feel comfortable using our products. This Instant Coffee Maker was designed with you and your safety in mind.

Read all instructions before using and only use this appliance as directed. Failure to follow these Important Safeguards may result in personal injury and/or property damage and will void your warranty.

When using electrical appliances, basic safety precautions should always be followed to reduce the risk of fire, electric shock, personal injury and/or property damage.

READ ALL INSTRUCTIONS

Placement

- **DO** operate the appliance on a stable, non-combustible, level surface.
- **DO NOT** place the appliance on or near a hot gas or electric burner, or in a heated oven.
- **DO NOT** move the appliance while it is in operation.

General Use

- **DO NOT** use this coffee maker outdoors.
- **DO NOT** Fill past waterline
- **DO NOT** fill the water reservoir with mineral water, milk or other liquids. Only fill the water reservoir with clean, cold water.
- **DO NOT** let the coffee maker operate without water.
- **DO NOT** use the appliance for anything than its intended use. Not for commercial use. For household use only.
- **DO** regularly inspect the appliance and power cord.
- **DO NOT** leave the appliance exposed to sun, wind, and/or snow.
- **DO** operate and store the appliance above 32°F / 0°C
- **DO NOT** leave the appliance unattended when in use.
- **DO NOT** allow children to operate the appliance; close supervision is required when any appliance is used near children.
- **DO NOT** let children play with this appliance.
- To avoid the risk of burn injury **DO NOT** open the top cover during or immediately after the brew process. Contents may be extremely hot. Allow contents to cool before opening lid.

⚠ WARNING

- **DO NOT** touch hot surfaces with unprotected hands.
- The use of an accessory not evaluated for use with this appliance may cause personal injuries and/or property damage.
- The container is designed for use with this appliance. It must never be used on a range top.
- **DO NOT** set a hot container on a wet or cold surface.
- **DO NOT** use a cracked container or a container having a loose or weakened handle.
- **DO NOT** clean container with cleansers, steel wool pads, or other abrasive material.

Care and Storage

- **DO** unplug from outlet when not in use before cleaning. Allow the appliance to cool before putting on or taking off parts, and before cleaning the appliance.
- **DO NOT** store any materials in the brewing chamber when not in use.

Power Cord

A short power-supply cord is used to reduce the risk resulting from it being grabbed by children, becoming entangled in, or tripping over a longer cord. Spilled liquids from this coffee maker can cause serious burns and/or property damage. Keep appliance and cord away from children.

Never drape cord over edge of counter and never use outlet below counter.

- **DO NOT** let the power cord touch hot surfaces or open flame, including the stovetop.
- **DO NOT** use with power converters or adapters, timer switches or separate remote-control systems.
- **DO NOT** let the power cord hang over the edge of tables or counters.
- **DO** unplug your coffee maker by grasping the plug and pull from the outlet. Never pull from the power cord.
- **DO NOT** attempt to modify the plug. If the plug does not fit full into the outlet, reverse the plug.
- **DO** contact a qualified electrician if the plug does not fit in the outlet.
- **DO** plug this appliance into a polarized outlet one way. This appliance has a polarized plug, and one blade is wider than the other.

This appliance has a polarized plug, with one blade wider than the other. To reduce the risk of electrical shock:

- **ONLY** plug this appliance into a polarized outlet. If the plug does not fit fully into the outlet, reverse the plug.
- **DO NOT** attempt to modify the plug in any way. If it still does not fit, contact a qualified electrician.

⚠ WARNING

Electrical Warning

The coffee maker contains electrical components that are an electrical shock hazard. Failure to follow these instructions may result in electric shock.

To protect against electrical shock:

- To reduce the risk of fire, property damage, personal injury, and/or electric shock, do not remove the bottom cover. No user-serviceable parts inside. Repair should be done by authorized service personnel only.
- To disconnect, turn any control to the off position and remove plug from power source. Always unplug when not in use, as well as before adding or removing parts or accessories, and before cleaning. To unplug, grasp the plug and pull from the outlet. Never pull from the power cord.
- **DO** regularly inspect the appliance and power cord. **DO NOT** operate the appliance if the power cord or plug is damaged, or after the appliance malfunctions or is dropped or damaged in any manner. For assistance, contact Customer Care by email at support@instanthome.com.
- **DO NOT** attempt to repair, replace or modify components of the appliance, as this may cause property damage, electric shock, fire or personal injury, and will void the warranty.
- **DO NOT** tamper with any of the safety mechanisms, as this may result in personal injury or property damage.
- **DO NOT** immerse power cord, plug or the appliance in water or other liquid.
- **DO** plug this appliance into a polarized outlet one way. This appliance has a polarized plug, and one blade is wider than the other.
- **DO NOT** use the appliance in electrical systems other than 120 V ~ 60 Hz for North America.
- A longer detachable power-supply cord or extension cord may be used with the following precautions:
 - The marked electrical rating of the detachable power-supply cord or extension cord should be at least as great as the electrical rating of the appliance.
 - The longer cord should be arranged so that it will not drape over the countertop or tabletop where it can be pulled on by children or tripped over.

SAVE THESE INSTRUCTIONS

WHATS IN THE BOX

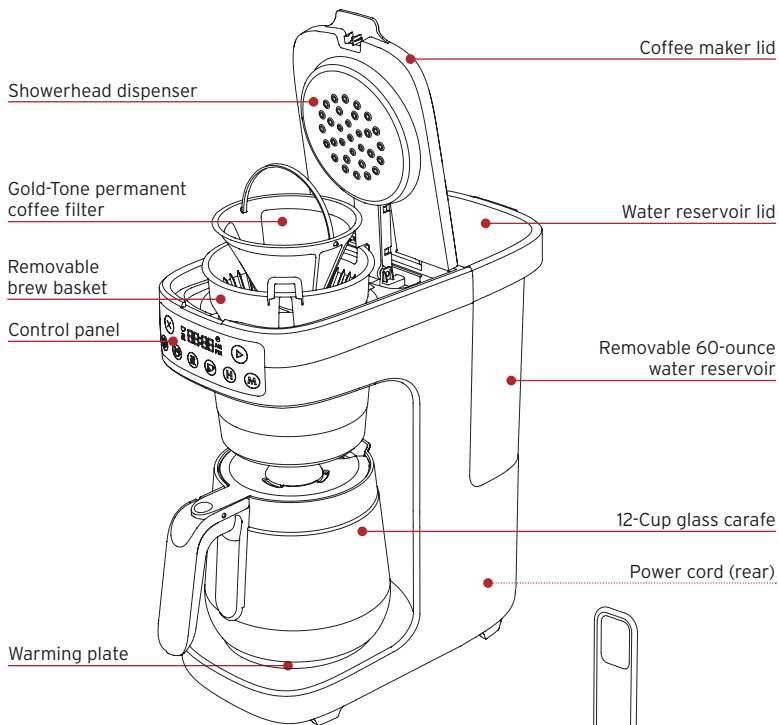

Accessories

Coffee measuring scoop

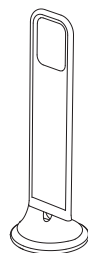
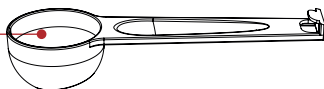

Integrated Carbon Filter



Illustrations are for reference only and may differ from the actual product.

Remember to recycle!

We designed our packaging with sustainability in mind. Be sure to recycle at a recycling center in your area.

USING YOUR INSTANT® INFUSION BREW PLUS

Control panel

We've designed the control panel to be simple and easy to read.

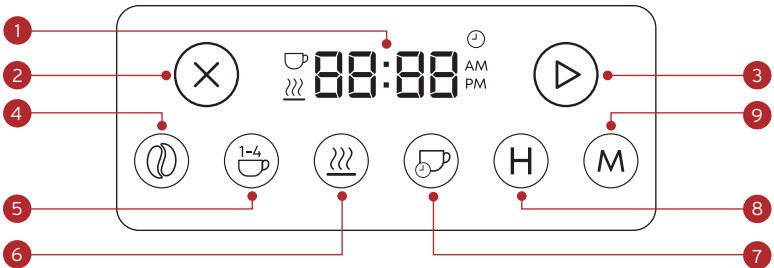

- | | |
|---------------------------|--------------------|
| 1. Clock/ display | 6. Warming Plate |
| 2. Cancel | 7. Auto-Brew/Timer |
| 3. Start | 8. Hours |
| 4. Bold setting | 9. Minutes |
| 5. Small batch (1-4 cups) | |

INITIAL SETUP

1. Pull the Instant® Infusion Brew Plus and all accessories out of the box.
2. Remove all packaging materials from within and around the unit.
3. Place the unit on a dry, stable and level surface.
4. Plug in your Instant® Infusion Brew Plus.
5. You will hear a beep and all display LED buttons will light up.

Note: After 30 minutes of inactivity, your coffee maker will enter standby mode. The LED control panel will dim. To exit standby mode, press any button or lift the coffeemaker lid.

Sound Settings

You can turn sound and reminder beeps on or off. The default sound setting when you open your coffee maker is ON.

1. Make sure your Instant® Infusion Brew Plus is on.
2. To turn sound off, press and hold the **Bold** and **Small Batch** buttons at the same time for 2 seconds. The message display will show **SOFF**.
3. To turn sound back on, repeat step 2. The message display will show **S On**.

Setting the Clock

When you first turn on your Instant® Infusion Brew Plus, the clock display will show the default time of 12:00 AM. Setting and changing the time is quick and easy.

1. Make sure your Instant® Infusion Brew Plus is turned on.
2. Press the **(H)** and **(M)** buttons until the correct time is set. To speed up, press and hold for 3 seconds.
3. Press **(D)** button to save the new time.
4. Your clock is now set!

Clean before use

1. Lift the water reservoir up to remove from the coffee maker.
2. Handwash the glass carafe, water reservoir, coffee filter and brew basket with warm water and dish soap. Rinse with warm, clear water. Wipe with a clean, dry cloth.
3. With a damp cloth, wipe down the coffee maker base and control panel.

Integrated Carbon Filter

The integrated carbon filter ensures your water is free of chlorine and other impurities before brewing for cleaner, tastier coffee. The filter cartridge contains activated charcoal and should be replaced every 60 days for the best results.

You will need to assemble and install the integrated carbon filter that comes with your machine before your first brew.

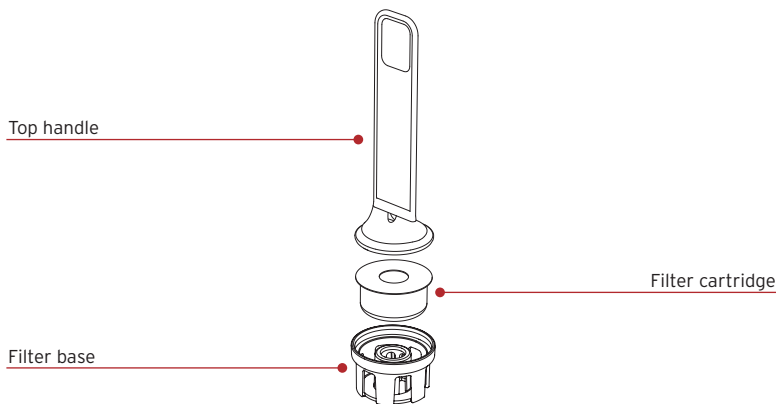

To assemble:

1. Remove the **filter base**, **top handle** and **filter cartridge** from its packaging.
2. Soak the **filter cartridge** in cool water for 10 minutes to activate it before using.

3. Place the fully soaked **filter cartridge** into the **filter base**.
4. Snap the **top handle** to the **filter base** to fully enclose the **filter cartridge**.

To install:

1. Place the assembled Integrated **carbon filter** into the **water reservoir**.
2. Press the **integrated carbon filter** into the port at the bottom of the **water reservoir** until it is firmly in place.

To replace the filter cartridge:

1. Pull the **top handle** to remove the **integrated carbon filter** from the **water reservoir**.
2. Unsnap the **top handle** from the **filter base** to remove the old **filter cartridge** and replace with a new one. See assembly instructions above.

*Always soak your new **filter cartridge** in water for 10 minutes before using for best results.*

Test Run

Before you brew your first carafe of coffee, we recommend flushing your Instant® Infusion Brew Plus to make sure the unit is clean and working correctly. **Do not use coffee for the test run.**

1. Remove the **water reservoir lid**. Lift the **water reservoir** from the back of the coffee maker.
2. Fill the **water reservoir** with cold water to the 12-cup fill line as indicated. *Be careful not to over-fill.*
3. Place the **water reservoir** back onto the coffee maker then replace **water reservoir lid**.
4. Place the **glass carafe** onto the **warming plate**, under the **removable brew basket**.
5. Ensure the **coffee maker lid** is closed. The ☉ button should light up. Press ☉ button to begin brewing.

6. After the brewing cycle ends, the keep warm setting will automatically activate and the **warming plate** will stay hot for 2 hours. Press the ⊗ button or the @ button to turn it off.

7. Carefully remove the **glass carafe** and discard the water.
CAUTION: The water and warming plate will be hot.

To stop brewing at any time press the ⊗ button.

8. Carefully place the **glass carafe** back on to the **warming plate** which may still be hot.

9. Your test run is complete and you're ready to start brewing!

BREWING COFFEE

Once you've cleaned your Instant® Infusion Brew Plus and all parts, and completed a test run, it's time to program your perfect brew.

Brewing the Perfect Coffee

Water	Coffee	Grind	Ratio
Coffee is 98% water. Use great tasting, cool, filtered water for the purest tasting coffee.	The tastiest, high-quality beans make the tastiest, smoothest coffee. Store whole beans in a cool place (or freezer) and grind just before brewing.	For the most flavorful coffee, choose a medium-fine grind when brewing with your Instant® Infusion Brew Plus. If you grind your own beans, grind just before brewing for maximum freshness.	Getting water to coffee ratios correct is key to great tasting brew that isn't too weak or too strong. See coffee measurements guide to start, then adjust to your personal taste.

Pre-Infusion Process

Your Instant® Infusion Brew Plus uses an innovative showerhead dispenser and pre-infusion process to extract maximum flavor with every brew. Pre-infusion gently soaks the ground coffee evenly with filtered water before brewing. Pre-infusion begins automatically during all brewing programs with your Instant® Infusion Brew Plus.

Brew Preferences and Programs

Your Instant® Infusion Brew Plus lets you choose how you want to brew for maximum taste and customization, and tasty coffee every time.

Bold Brew

If you prefer a stronger, richer coffee, the Bold Brew setting has been programmed to extract even deeper flavor from the coffee grounds by increasing the brewing time slightly.





The Bold Brew button will illuminate when selected.

You can toggle between Classic and Bold Brew settings depending on your personal preference.

For brew that tastes...	Choose this brew strength
Medium flavor, easy drinking, balanced. Great morning coffee.	Classic
Deep, rich flavor, smooth. Holds up well to cream/milk and other flavorings.	Bold

Auto-Brew Timer

Set your timer before bed and wake up to perfectly brewed coffee ready for you to enjoy! You can set your brew to automatically start, up to 24 hours in advance.

- Make sure the clock is set to the current time. See 'Setting the Clock' on page 7.
- Press the  button then press the  and  buttons to set the brew time you want.
- Press . The  button will illuminate and a tone will play confirming the new brew time is set.

Small Batch Brewing



Use this setting when you are brewing fewer than 4 cups of coffee. Small batch brewing adjusts the brew process to ensure full flavor and less waste, whether you want a lot of coffee or a little.

Keep Warm



Once your coffee has finished brewing, the Keep Warm setting keeps it fresh and hot for up to 4 hours. The default warming is set at

2 hours on High temperature. Default warming settings can only be changed while in Ready mode, before brewing.

To change the Keep Warm settings:

1. Press and hold the  button for 3 seconds to change the default warming temperature or time.
2. To change the temperature, press the  button to select **Low**, **Medium** or **High**.

Note: The current warming temperature can be changed during or after brewing, once the warming plate has turned on.

3. To change the time, press the  and  buttons and toggle through Hours and Minutes.



Note: you cannot change the time on the warming plate once warming starts.

4. Press the  button to confirm choices.

Once you save your preferences, they are stored as your new default settings for quick and easy brewing next time. You can change settings anytime.

Coffee Measurement Chart

We recommend using a medium-fine grind of coffee with your Instant® Infusion Brew Plus. This will give you optimal results and the smoothest flavor.

Batch Size	Cups	Grounds	Water
Small batch  button is on	4 cups	4 rounded scoops or 6 Tbsp.	4-cup line
Full carafe  button is off	6 cups	6 rounded scoops or 9 Tbsp. or 1/2 cup + 1 Tbsp.	6-cup line
	8 cups	8 rounded scoops or 12 Tbsp. or 3/4 cup	8-cup line
	10 cups	10 rounded scoops or 15 Tbsp. or 3/4 cup + 3 Tbsp.	10-cup line
	12 cups	12 rounded scoops or 18 Tbsp. or 1 cup + 2 Tbsp.	12-cup line

How to brew coffee









Prep

1. Lift the **water reservoir lid** to open. Remove the **water reservoir** by pulling straight up.
2. Fill the **water reservoir** to desired level. See “Coffee Measurements” for suggested quantities above.



CAUTION: DO NOT attempt to brew if the water level is below the **MIN fill line**.

3. If using coffee beans, grind them down to a medium or medium-fine consistency.

Brew

1. Lift the **coffee maker lid** and place the **removable brew basket** into the basket holder, making sure it's secure. Insert the **gold-tone coffee filter** (or a #4 cone paper filter) into the **removable brew basket**.
2. Add desired amount of ground coffee into the gold-tone coffee filter. See “Coffee Measurements” table above.
3. Close the **coffee maker lid**. The green  button will turn on. Note: the coffeemaker lid must be closed for brewing to start.
4. Choose preferred strength: press the  button for stronger, bolder brew flavor, if desired. The button light will illuminate. Press the  button again to turn off light and brew at classic strength.*
5. Choose small batch or full carafe: Press  if you are brewing fewer than 5 cups. The selected button will illuminate. If you are brewing a full carafe leave this off.*
6. If brewing immediately, press  to keep default settings and brew right away. Or see Step 5 to change your default settings. You can set auto-brew for up to 24 hours ahead of time.
7. Choose brew time: press the  button. Either the default time of 12:00 or the previously set time will flash on the display. Press the  and  buttons to adjust your desired start time.

8. Press the green  button to confirm time.

To accelerate through the selections, press and hold the  and  buttons.

You can cancel brewing and return to Ready mode at any time by pressing the  button.

9. Every brew has an automatic pre-infusion cycle. Brewing will begin, pause briefly as the coffee grounds are saturated, then continue brewing.
10. When brewing is complete, automatic warming will begin. See “Keep Warm” above.
11. Enjoy your freshly brewed coffee!

**Note: Saved settings will activate when you press  button the next time you brew. You can change these at any time.*

WARNING

To avoid the risk of burn injury and/or property damage DO NOT open the coffee maker lid during or immediately after the brew process. Water may be extremely hot.

Allow contents to cool before opening the lid.

CARE, CLEANING AND STORAGE

Clean your Instant® Infusion Brew Plus regularly to ensure the best possible flavor and to prevent mineral deposits from building up in the coffee maker.

Always let parts cool to room temperature before cleaning. Never use metal scouring pads, abrasive powders, or harsh chemical detergents on any of the coffee maker's parts.

Let all parts dry thoroughly before use and before storage.

Instant® Infusion Brew Plus Part/ Accessory	Cleaning methods and instructions
<ul style="list-style-type: none">Removable water reservoirGlass carafe	<ul style="list-style-type: none">Remove the reservoir and hand wash with dish soap and warm water.Not dishwasher safe.
<ul style="list-style-type: none">Removable brew basketGold-Tone coffee Filter	<ul style="list-style-type: none">Remove and hand wash with dish soap and warm water or place in the top rack of a dishwasher.
Coffee maker / LED panel	<ul style="list-style-type: none">Use a damp dish cloth to clean the outside of the coffee maker and LED panel
Power cord	<ul style="list-style-type: none">DO NOT fold power cord when storing.

CAUTION To avoid fire, electric shock, personal injury and/or property damage:

- Hand wash only.
- DO NOT** rinse or immerse the coffee maker, power cord, or plug in water or other liquids.

Any other servicing should be performed by an authorized service representative. For assistance, contact Customer Care at support@instantcare.com.

Descaling / Removing Mineral Deposits

With regular use minerals may accumulate in the coffee maker, which can affect the temperature and strength of your brew.

To make sure your coffee maker stays in tip top shape, descale it regularly to keep mineral deposits from building up. Your Instant® Infusion Brew Plus has a built-in cycle for quick and easy cleaning.

After 90 cycles, the ☒ button light will turn on and the Ⓜ and Ⓜ button lights will flash to remind you to clean and descale your coffee maker. You will have two options:

Cancel cleaning

Press the ☒ button to exit reminder mode and return to Ready mode. Your coffee maker will not begin cleaning and the brew cycle counter will reset.

Start automatic cleaning cycle.

Follow instructions in “How to Descale your Instant Coffee Maker Plus” below.

Once the cleaning cycle is completed, the brew cycle counter will reset (counting up to 90) and the device returns to Ready mode.

How to Descale your Instant® Infusion Brew Plus

1. Combine cleaner and water as shown in the table “*Descaling Solution Ratio*” below.
2. Fill the **water reservoir** to the **MAX** line with the cleaning mixture.
3. Place the **glass carafe** under the **removable brew basket**. Make sure the **coffee maker lid** is closed.
4. Press and hold the Ⓜ and Ⓜ buttons for 3 seconds.
5. The Ⓜ and Ⓜ buttons will flash slowly and the cleaning mixture will pass through the appliance until the water reservoir is empty.
6. Discard the cleaning mixture from the **glass carafe**. Be careful: the mixture will be **HOT**.
7. Return the emptied **glass carafe** under the drip nozzle.
8. Remove and rinse the **water reservoir** and fill to the **MAX** line with cool, clean water. Make sure the **coffee maker lid** is closed.
9. Press and hold the Ⓜ and Ⓜ buttons for 3 seconds. *The cleaning mixture will pass through the appliance until the water reservoir is empty.*
10. Discard the water from the **glass carafe**. The unit is now clean and ready to use again.

Descaling Solution Ratio

Cleaner	Cleaner to water ratio
Household descaler	1 : 4
Citric acid	3 : 100

TROUBLESHOOTING

Problem	Cause	Solution
There is sediment/grounds in my coffee.	<ul style="list-style-type: none">• The grind of coffee may be too fine for the removable filter.• You forgot to place a coffee filter into the brew basket before brewing.• Using too many grounds can cause the filter holder to overflow.	<ul style="list-style-type: none">• Try using a slightly coarser grind. Finely ground coffee can clog the filter holder. For best brewing results, use a medium-grind coffee• Either the permanent filter or a paper filter must be in place when brewing.• Once cooled, clean out the filter holder and refill using the appropriate amount of coffee (1 scoop per cup).
Coffee is too weak	<ul style="list-style-type: none">• Classic brew setting was selected.• Lighter roast coffee.• Not enough ground coffee added.	<ul style="list-style-type: none">• For stronger flavor, try choosing the bold setting [coffee bean button].• Use a darker roast.• Add additional coffee grounds.
Coffee is too strong	<ul style="list-style-type: none">• Bold brew setting was selected.• Coffee roast was too dark.	<ul style="list-style-type: none">• Try Classic brew setting. Press  button to turn off Bold brew.• Use a lighter roast.• Use fewer grounds.
The carafe overflowed during brewing cycle	<ul style="list-style-type: none">• The carafe wasn't empty before brewing.• Water reservoir was filled above the MAX line	<ul style="list-style-type: none">• Make sure carafe is empty.• Only add water to the MAX line (60 oz) additional water to the reservoir after a brew or cleaning cycle has already started.

Problem	Cause	Solution
<p>Brew cycle will not start</p> <ul style="list-style-type: none"> NOTE: As part of the pre-infusion process, the brew will start, pause briefly and then continue. 	<ul style="list-style-type: none"> Coffee maker not turned on. Coffee maker lid is not closed. There is no water in the removable water reservoir. The glass carafe is not placed on the drip tray correctly. 	<ul style="list-style-type: none"> Ensure the unit is powered on and the display is illuminated. If there are no lights, the machine is not getting power. Try a different outlet. Check to make sure there is water in the water reservoir. Make sure the carafe is in place. The brewer will not dispense coffee if the carafe is not in place.
<p>Coffee maker is making unknown or strange sounds and/or buttons are flashing.</p>		<p>Contact Consumer Care at support@instanthome.com</p>

LEARN MORE

There's a whole world of Instant Coffee Maker information and help just waiting for you. Here are some of the most helpful resources.

Register your product

[Instanthome.com/register](https://instanthome.com/register)

Contact Consumer Care

In the Instant Brands Connect App
[Instanthome.com/customer-care-center](https://instanthome.com/customer-care-center)
support@instanthome.com

Instant Brands® Connect App

[Instanthome.com](https://instanthome.com)
iOS and Android app stores

Replacement parts and accessories

[Instanthome.com](https://instanthome.com)

Join the community



Product specifications

Model	Volume	Wattage	Power	Weight	Dimensions
DCM-1100	60 oz / 1774 mL water reservoir	1400 W	120V/ 60Hz	6.57 lb 2.98 kg	in: 14.1 H x 6.9 W x 14.4 D cm: 35.9 H x 17.6 W x 36.6 D

WARRANTY

One (1) Year Limited Warranty

This One (1) Year Limited Warranty applies to purchases made from authorized retailers of Instant Brands LLC ("Instant Brands") by the original appliance owner and is not transferable. Proof of original purchase date and, if requested by Instant Brands, return of your appliance, is required to obtain service under this Limited Warranty. Provided the appliance was used in accordance with the use & care instructions, Instant Brands will, in its sole and exclusive discretion, either: (i) repair defects in materials or workmanship; or (ii) replace the appliance. In the event that your appliance is replaced, the Limited Warranty on the replacement appliance will expire twelve (12) months from the date of receipt. Failure to register your product will not reduce your warranty rights. The liability of Instant Brands, if any, for any allegedly defective appliance or part will not exceed the purchase price of a comparable replacement appliance.

What is not covered by this warranty?

- Products purchased, used, or operated outside of the United States and Canada.
- Products that have been modified or attempted to be modified.
- Damage resulting from accident, alteration, misuse, abuse, neglect, unreasonable use, use contrary to the operating instructions, normal wear and tear, commercial use, improper assembly, disassembly, failure to provide reasonable and necessary maintenance, fire, flood, acts of God, or repair by anyone unless directed by an Instant Brands representative.
- Use of unauthorized parts and accessories.
- Incidental and consequential damages.
- The cost of repair or replacement under these excluded circumstances.

EXCEPT AS EXPRESSLY PROVIDED HEREIN AND TO THE EXTENT PERMITTED BY APPLICABLE LAW, INSTANT BRANDS MAKES NO WARRANTIES, CONDITIONS OR REPRESENTATIONS, EXPRESS OR IMPLIED, BY STATUTE, USAGE, CUSTOM OF TRADE OR OTHERWISE WITH RESPECT TO THE APPLIANCES OR PARTS COVERED BY THIS WARRANTY, INCLUDING BUT NOT LIMITED TO, WARRANTIES, CONDITIONS, OR REPRESENTATIONS OF WORKMANSHIP, MERCHANTABILITY, MERCHANTABLE QUALITY, FITNESS FOR A PARTICULAR PURPOSE OR DURABILITY.

Some states or provinces do not allow for: (1) the exclusion of implied warranties of merchantability or fitness; (2) limitations on how long an implied warranty lasts; and/or (3) the exclusion or limitation of incidental or consequential damages; so these limitations may not apply to you. In these states and provinces, you have only the implied warranties that are expressly required to be provided in accordance with applicable law. The limitations of warranties, liability, and remedies apply to the maximum extent permitted by law. This limited warranty gives you specific legal rights, and you may also have other rights which vary from state to state or province to province.

Product Registration

Please visit www.instanthome.com/register to register your new Instant Brands appliance. Failure to register your product will not diminish your warranty rights. You will be asked to provide the store name, date of purchase, model number (found on the back of your appliance) and serial number (found on the bottom of your appliance) along with your name and email address. The registration will enable us to keep you up to date with product developments and recipes, and contact you in the unlikely event of a product safety notification. By registering, you acknowledge that you have read and understand the instructions for use, and warnings set forth in the accompanying instructions.

Warranty Service

To obtain warranty service, please contact our Consumer Care Department by email to support@instanthome.com. You can also create a support ticket online at www.instanthome.com. If we are unable to resolve the problem, you may be asked to send your appliance to the Service Department for quality inspection. Instant Brands is not responsible for shipping costs related to warranty service. When returning your appliance, please include your name, mailing address, email address, phone number, and proof of the original purchase date as well as a description of the problem you are encountering with the appliance.

Distributed by Instant Brands LLC
3025 Highland Parkway, Suite 700
Downers Grove, IL 60515 U.S.

instanthome.com

© 2022 Instant Brands LLC
140-0097-01

Art release date
11/08/2022

INSTANT and INSTANT BRANDS
are registered trademarks of
Instant Brands Holdings Inc.