

USER GUIDE

INVERTER PRO

PURE SINE WAVE WITH ATS & RCD



CONTENTS

1.	Overview	3
	Key Features	3
	Product Overview	4
	Remote Overview (Sold Separately)	6
	LED Indicators	7
	Fault LED Indicators	7
2.	Installation	8
	Automatic Transfer Switch	8
	AC 240V Input Installation	9
	AC Output Installation	10
	Chassis Grounding	11
	Connecting the Battery	11
	Basic Setup Diagram	12
	Remote Installation	13
	Mounting Requirements	14
	Cable & Fuse Guide	15
	Battery Preparation	16
3.	Operation	16
	Operating the Inverter	16
	AC 240V Output Overview	18
4.	Specifications	19
5.	Safety Precautions	20
6.	Contact Us	Back Page

OVERVIEW

The iTechworld PRO Inverter range was designed and developed to convert your 12V power from your battery system into safe and reliable 240V power. This allows you to operate appliances you'd typically have to stay at home to use, from the comfort of your caravan, camper, or 4WD.

The PRO range come equipped with an automatic transfer switch and external RCD.

KEY FEATURES

- In-Built Automatic Transfer Switch
- In-Built RCD Protection
- Pure Sine Wave Output
- Optional Remote
- Virtually Silent
- Lower Total Harmonic Distortion
- Extensive Internal Safety Features

Accessory List

 <p>IEC Output Adaptor</p>	 <p>Type I to IEC Input Cable</p>	 <p>User Manual</p>
---	--	--

PRODUCT OVERVIEW

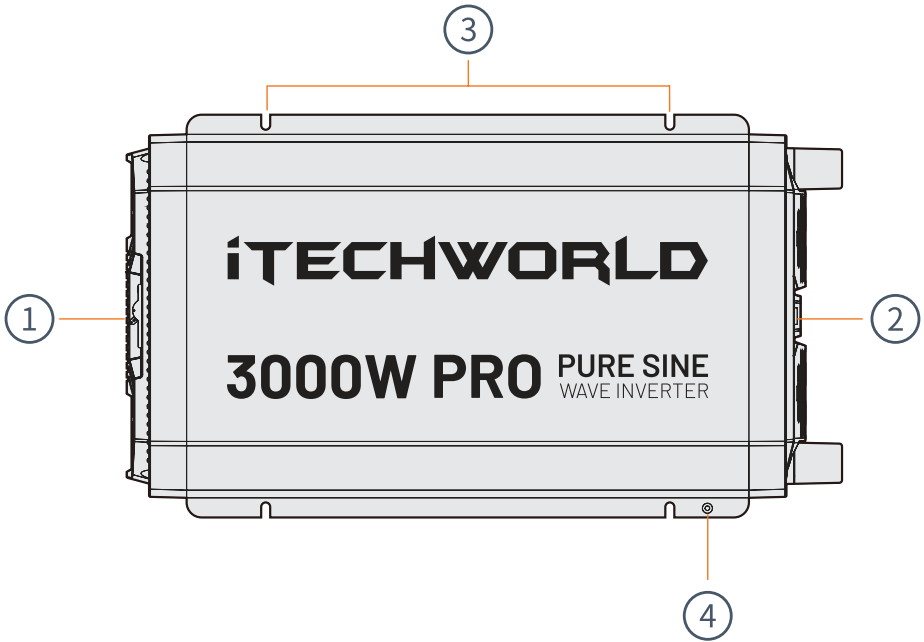

① **OUTPUT SIDE**

② **INPUT SIDE**

③ **MOUNTING BRACKETS**

④ **CHASSIS GROUND**

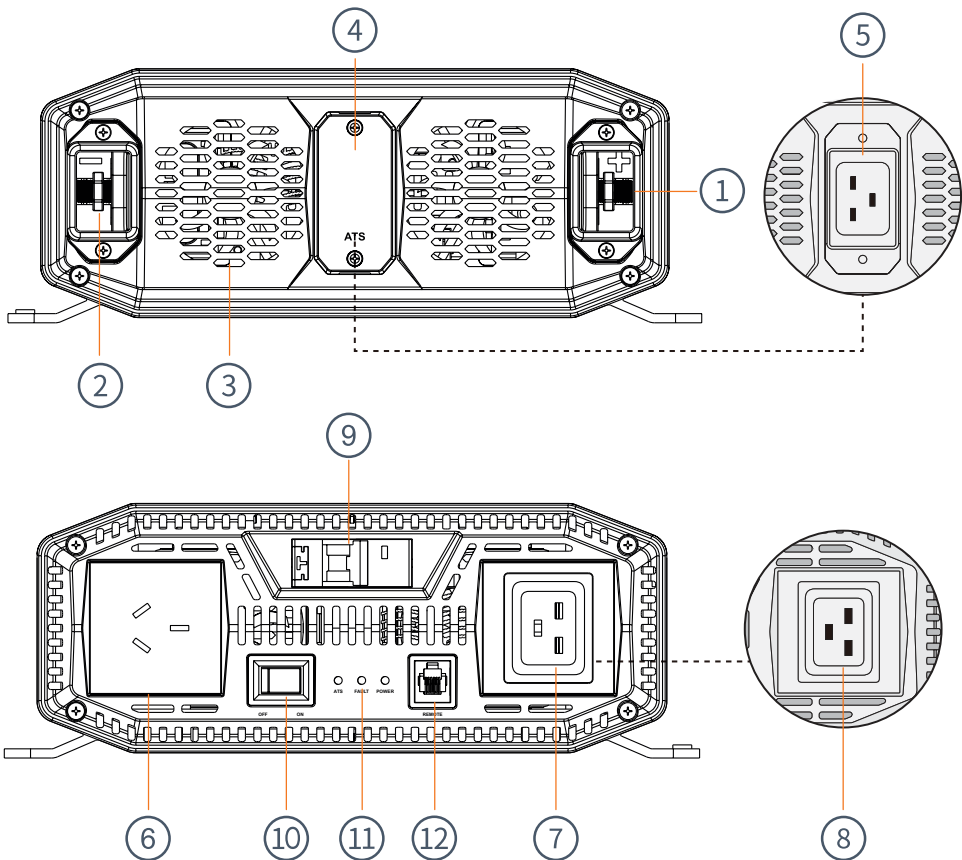

- | | |
|------------------------------|-------------------------------|
| ① POSITIVE TERMINAL | ⑦ IEC-C13 OUTPUT PORT (2000W) |
| ② NEGATIVE TERMINAL | ⑧ IEC-C19 OUTPUT PORT (3000W) |
| ③ COOLING FAN | ⑨ EXTERNAL RCD |
| ④ IEC-C14 INPUT PORT (2000W) | ⑩ POWER SWITCH |
| ⑤ IEC-C20 INPUT PORT (3000W) | ⑪ LED INDICATORS |
| ⑥ 240V OUTPUT PORT | ⑫ REMOTE PORT |

REMOTE OVERVIEW (SOLD SEPERATELY)

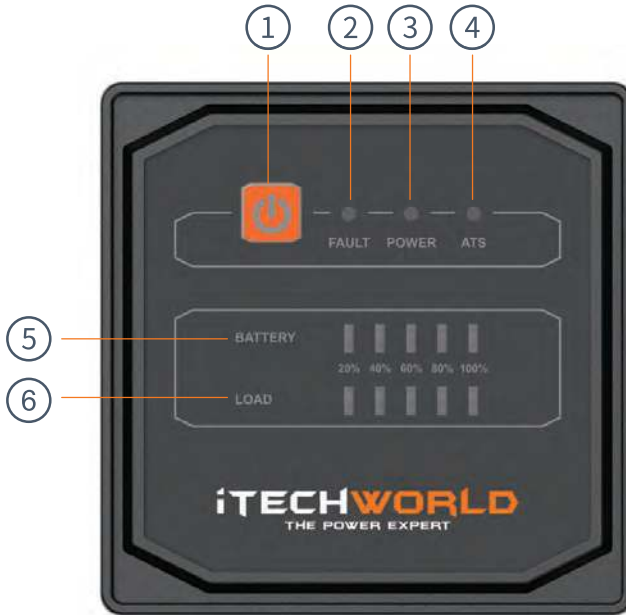

The inverter remote provides you with the ability to control the inverter's basic features from a more convenient location. For the remote to function, the on/off switch on the inverter must be turned on.

- | | |
|--------------------------|---|
| ① POWER BUTTON | Press and hold for 3 seconds to turn the inverter on/off. |
| ② FAULT LED | Illuminated when the inverter encounters a fault. |
| ③ POWER LED | Illuminated when the inverter is on and flashes when inverter is off. |
| ④ ATS LED | Illuminated when the inverter is running from AC input. |
| ⑤ BATTERY VOLTAGE | The battery voltage is based on the DC input voltage. |
| ⑥ LOAD DISPLAY | The load display is based on the current inverter load. |

LED INDICATORS

Status	LED Light		
	Fault LED	Fault LED	Fault LED
Standby	Flashing	Flashing	Flashing
In Use (No ATS)	ON	OFF	OFF
In Use (with ATS)	ON	OFF	ON
Fault	ON	Flashing	OFF

FAULT LED INDICATORS

Fault LED	Fault	Solution
Flashes Once	Over / Under Voltage Protection Activated	Isolate the inverter for 60 seconds, ensure the input voltage is between 10.5V - 15.5V.
Flashes Twice	AC Output Short Circuit Detected	Isolate the inverter, inspect your appliance, then reconnect the appliance.
Flashes 3 Times	Over / Under Temperature Protection Activated	Isolate the inverter, ensure the temperature is within -10°C and 50°C.
Flashes 4 Times	AC Output Overload Detected	Isolate the inverter and ensure the total draw of your appliance/s does not exceed the rated maximum of the inverter.
Flashes 5 Times	Internal Fault Detected	Isolate the inverter, then reconnect the appliance. If you are still experiencing issues, please contact the iTechworld service centre.

INSTALLATION

AUTOMATIC TRANSFER SWITCH

The ATS function enables the inverter to automatically switch from using 12V to AC 240V. It is beneficial for preserving your batteries and is used in situations where you opt to run your system from a powered site. Once the inverter detects incoming AC 240V current, the ATS function will activate, which will seamlessly switch the inverter input from 12V to AC 240V within 30ms.

Before installing the inverter into your system, ensure the unit is switched off and that there are no devices plugged into the AC 240V outputs.

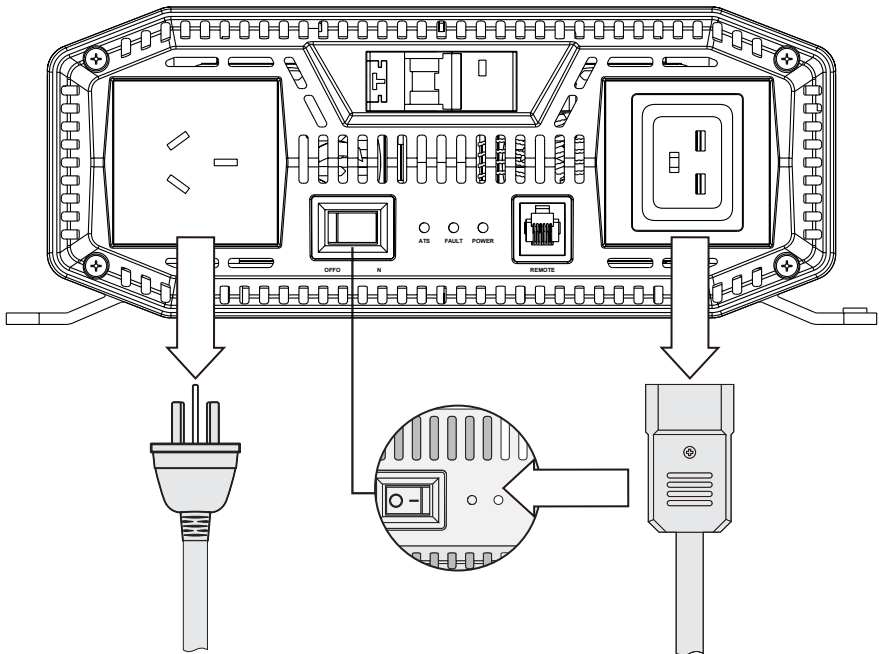

THIS STEP SHOULD BE COMPLETED BEFORE THE INSTALLATION SECTION.

AC 240V INPUT INSTALLATION

Before connecting the AC input, ensure you have the following cables on hand.

AC INPUT CABLE	2000W PRO	3000W PRO
INPUT END	IEC-C13	IEC-C19
MAINS END	Type 1	Type 1

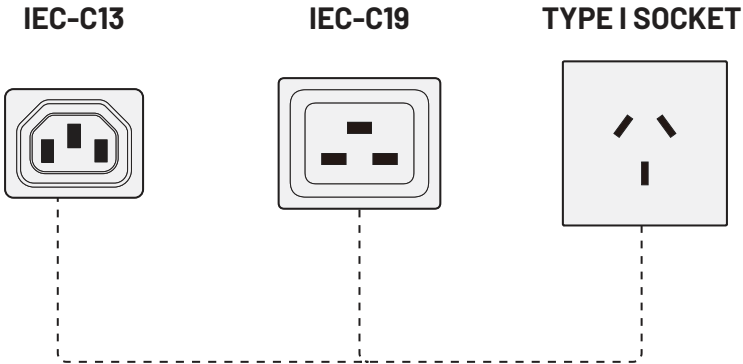

Connecting the inverter to AC 240V is straight forward. Simply insert the IEC plug into the inverters AC input, and then insert the 3 - pin plug into an AC 240V socket or power point. The inverter is designed to automatically switch to AC 240V power when available, ensuring smooth operation.

 **We recommend this install is done by a licensed electrician.** 

AC OUTPUT INSTALLATION

 We recommend this install is done by a licensed electrician. 

Before installing the inverter into your system, ensure the unit is switched off and that there are no devices plugged into the AC 240V outputs.

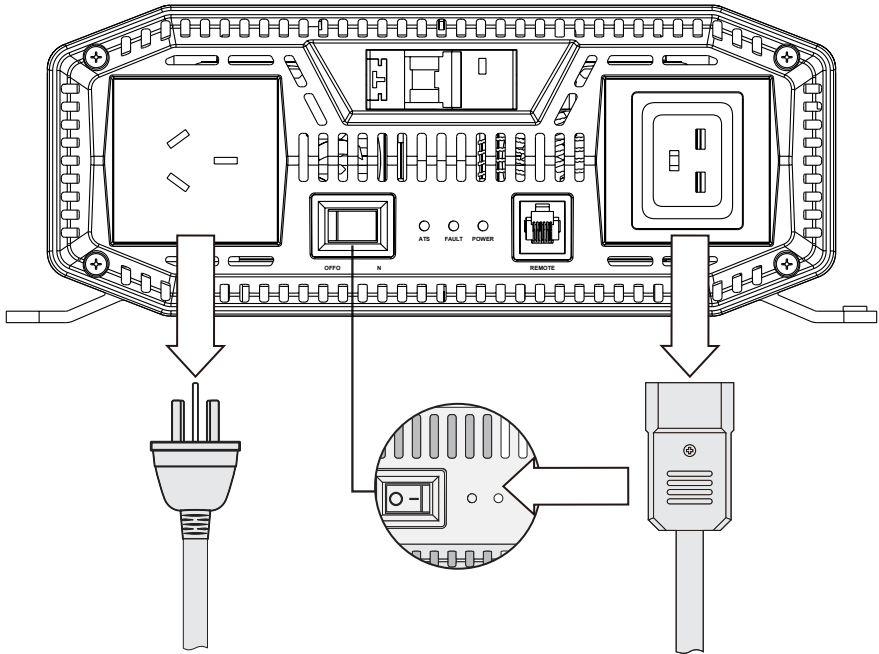

THIS STEP SHOULD BE COMPLETED BEFORE THE INSTALLATION SECTION.

CHASSIS GROUNDING

Grounding of the inverter is mandatory before use to prevent damage or injury.

Locate the grounding point on the provided mounting bracket near the negative terminal of the inverter. Ground the inverter by securely attaching a copper cable which is at least 4mm². Connect the other end of the mentioned copper cable to a suitable earthing point, such as your vehicles frame or the grounded negative terminal of the battery.

Please consult a licensed electrician to ensure your application meets Australian / New Zealand standards.

CONNECTING THE BATTERY

1. Before connecting the inverter to a battery, ensure you have the correct cable sizes and fuses.
2. Begin by removing the plastic inverter terminal covers, loosen the screws at on the top and bottom of the terminal covers to remove them. Slide these covers over the leads you'll be using to connect to the inverter.
3. Remove the nuts and washers from the inverter terminals.

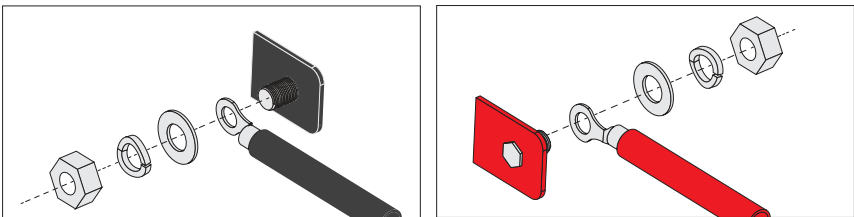

1. Attach the positive and negative cable to their respective input terminal. Thread the cable eye and washer over the bolt, then secure it with a nut to ensure a tight connection, repeat this step for both sides.
2. Re-install the inverter terminal covers.
3. Connect the positive and negative inverter cables to the battery or DC power source. First, attach the positive terminal, followed by the negative terminal.

Ensure the positive lead has an appropriately sized and placed fuse for added safety.

BASIC SETUP DIAGRAM

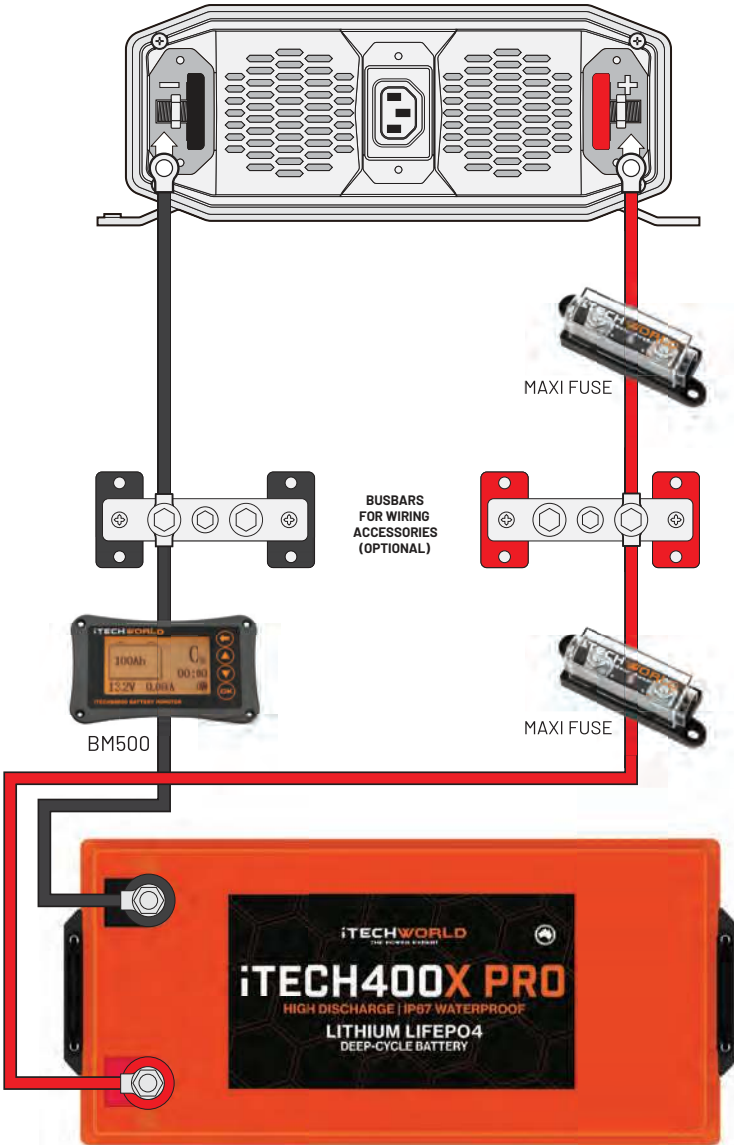

REMOTE INSTALLATION (SOLD SEPARATELY)

The remote allows the inverter to be operated from a distance, making it perfect for installations where the inverter is not easily accessible.

1. Select a space you would like the inverter remote to be installed, preferably away from moisture in a canopy or caravan wall.
2. Refer to the mounting diagram below for the dimensions of the hole you will have to make.
3. Drill 2mm holes on the designated mounting points and cut a hole in the mounting surface according the diagram above.

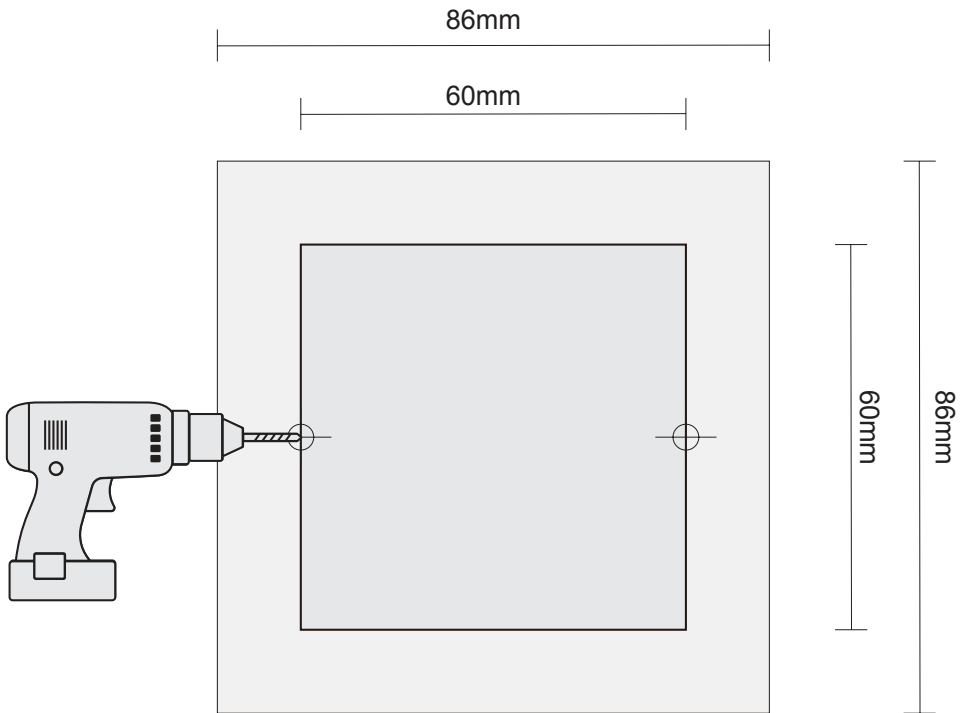

4. Remove the faceplate of the inverter remote by pulling on the small recess along one of the outer edges.
5. Insert the remote into the prepared hole and secure it in place using M3 screws to ensure a secure fitment.
6. Reattach the inverter remote faceplate and connect the included RJ12 cable to the core

MOUNTING REQUIREMENTS

When mounting the inverter, please adhere to the following guidelines:

VENTILATION - Provide at least a 100mm space around the inverter to prevent heat build up.

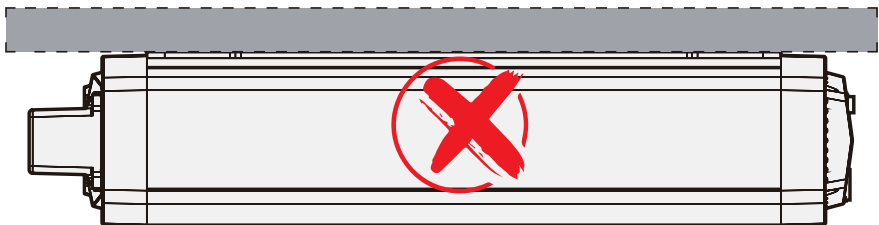

ORIENTATION - Ideally, mount the inverter horizontally on a flat surface with the base facing downwards. Vertical mounting is ok however this may put stress on the circuit board. Do not mount the inverter upside down (with the base facing up).

STABLE - Ensure the inverter is mounted on a sturdy surface capable of supporting its weight, utilising all of the mounting points with the correct fasteners.

DRY - Mount the inverter in an area free from moisture.

COOL - Opt for a mounting location that stays within 0°C and 40°C.

SAFE - Ensure the mounting area is free from fumes and other potential hazards.

LIMIT DUST - Mount the inverter in an area with minimal dust ingress to prevent dust from being drawn in by the fans during operation.

ELECTRICAL - Position the inverter close to the battery to minimise voltage drop. Maintain a distance of at least 300mm between the inverter and the battery. Install a fuse on the positive cable between the inverter and the battery, placing the fuse close to the battery end to protect the cable.

CABLE & FUSE GUIDE

The cable between the inverter and battery must be thick enough to prevent voltage drop. Since voltage drop happens between the battery positive and ground, the total length of both cables must be considered.

NOTE: *The cables should be routed in a way that reduces the risk of damage. Consider using cable conduit or protective tubing to mitigate this risk to ensure*

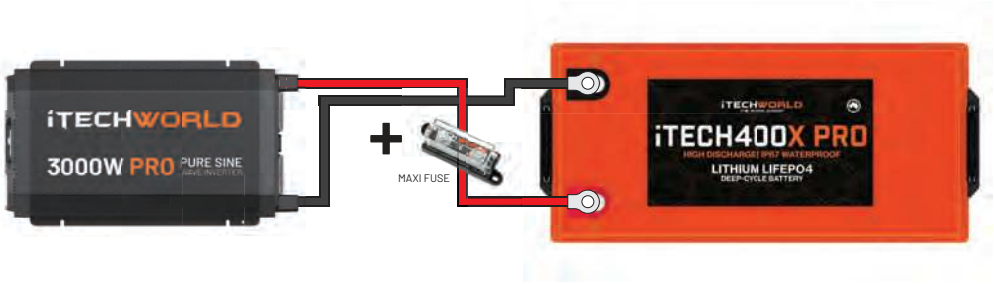

LENGTH	SIZE (AWG)	
	2000W PRO	3000W PRO
0-1M	70mm ² (2/0)	95mm ² (3/0)
1-2M	70mm ² (2/0)	95mm ² (3/0)
2-3M	95mm ² (3/0)	120mm ² (4/0)

MODEL	2000W PRO	3000W PRO
FUSE SIZE	250A	450A

BATTERY PREPERATION

Before installing your inverter, it is essential to verify your batteries are 12v and is one of the following chemistries: SLD, AGM, GEL, or LiFePO4.

The inverters are also capable of being connected to batteries in parallel. Paralleling an iTechworld battery with a compatible iTechworld battery of the same Ah and type will increase the maximum continuous discharge rate.

MODEL	2000W PRO	3000W PRO
MAX CONSTANT AMP DRAW	185A	278A



OPERATION

OPERATING THE INVERTER

Once you've wired the input side, your inverter is ready to power your 240V appliances.

Before operating the inverter, ensure the total wattage of the appliance/s you intend to use is below the rated wattage of the inverter.

1. If you're powering the inverter from a 12V source, ensure that the battery has enough charge to support the draw. For AC 240V input, ensure there is a secure connection.
2. Verify the RCD is in the correct position, do not proceed if this if it has been tripped - seek assistance from a licensed electrician.
3. Plug the appliance into the AC 240V output or IEC 240V socket.
4. Turn on the inverter. If you're using AC 240V input, ensure that the mains AC 240V supply is also turned on.
5. Turn on your appliance/s.

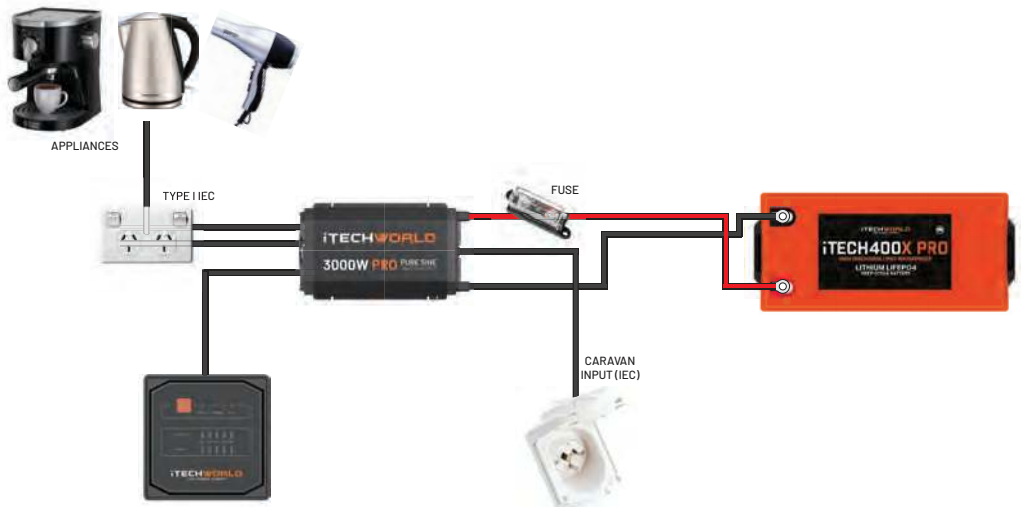

AC 240V OUTPUT OVERVIEW

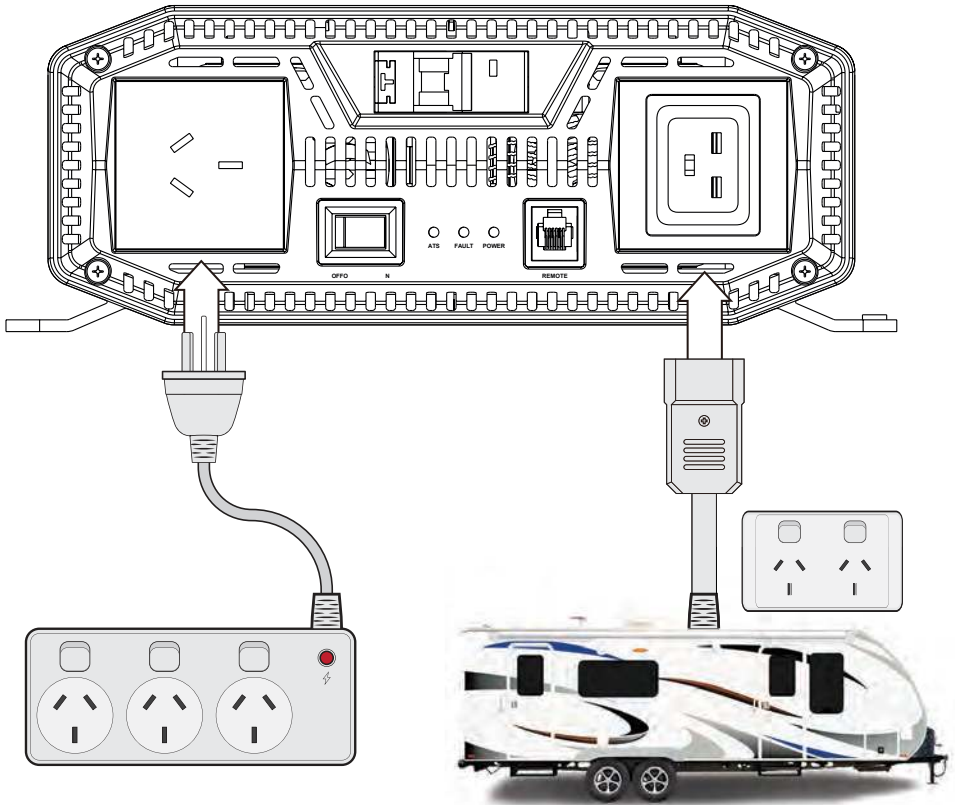

AC 240V OUTPUT

Each inverter is equipped with standard Type I AC 240V and specialised IEC sockets for appliances. You have the option to directly plug the appliance into the inverter or use a power board to power multiple appliances simultaneously.

It is important to note you can only connect appliances with a wattage the same or below the rated max of the specific inverter. For instance, iTechworld 3000W PRO inverter has a maximum continuous output of 3000W. So you will have to ensure the combined wattage of all the connected devices does not exceed 3000W.

Model	AC Output Interface
2000W PRO	10A IEC C13 and 10A Type I
3000W PRO	16A IEC C19 and 15A Type I

SPECIFICATIONS

General		
Model Name	2000W PRO	3000W PRO
Max Continuous Output	2000W	3000W
Peak Output	4000W	6000W
Battery Type Compatibility	SLD, AGM, GEL, or LiFePO4.	
Input Voltage Range	10.5V - 15.5V	
Output Plug Rating	10A	15A
Output Voltage & Current	240V ~ 50Hz	
No Load Draw	<1.3A	<1.6A
Efficiency	90%	
Output Waveform	Pure Sine Wave	
Total Harmonic Distortion	<3%	
IP Rating	IP22	
Operating Temperature	-10°C-50°C	
Storage Temperature	-30°C-70°C	
Dimensions	459 x 265 x 97mm	514 x 289 x 105mm
Protections		
Safety Features	Over / Under Voltage Protection, Short Circuit / Overload Protection	
	Over / Under Temperature Protection	
Over Voltage Protection	15.5±0.2V DC	
Under Voltage Protection	10.5±0.2V DC	
Short Circuit Protection	1 Second	
Automatic Transfer Switch		
Output Power	3600W	
Acceptable Voltage	220V ~ 240V	
AC Transfer Switch	30ms	
Remote		
Terminal	RJ12	
Dimensions	86 x 86 x 19mm	

The iTechworld PRO Inverter Range comply with AS/NZS 4763:2011 and IEC/EN 62368-1 including Australian deviations. The external RCD complies with IEC 61810-1.

SAFETY PRECAUTIONS

For safe operation and optimal performance, the iTechworld Pure Sine Wave Inverter PRO must be installed and operated correctly. Please carefully read, understand, and follow all instructions and guidelines in this user guide. iTechworld recommends that a certified technician install the iTechworld Pure Sine Wave Inverter PRO. Failure to follow these instructions may result in damage to the unit, property, death, or serious injury.

Disclaimer: While iTechworld has taken every precaution to ensure the accuracy of the contents of this user guide, iTechworld assumes no responsibility for any errors or omissions.

Furthermore, all specifications and functionality may change at any time without notice.

It is best to view our website for the most up-to date information

WARNING:

This inverter generates AC 240V power which may cause death or severe injury. Even with the inverters advanced internal safety features, caution should be used when operating the unit.

WARNING:

People with physical disabilities, visual, sensory, or mental impairments (including children) should not use this inverter. Children should be supervised to ensure they do not play with Inverters.

WARNING:

Please use the fuses and wires recommended in this user guide, otherwise, it may result in damage to the inverter, a risk of electrical shock, fire, death, or serious injury.

WARNING:

Do not try to jumpstart a vehicle with this battery box.

WARNING:

Ensure the continuous output of this inverter does not exceed the battery's recommended discharge rate. If you are unsure of the recommended discharge rate, please consult your battery's manufacturer. Damage to the power station, a risk of electrical shock, fire, death, or serious injury.

DANGER:

Do not disassemble or modify the inverter, doing so may result in a risk of electrical shock, fire, death, or serious injury.

DANGER:

This inverter is only suitable for battery types listed in the user guide. Do not use it for other purposes.

DANGER:

Do not connect the inverter with reverse polarity, as doing so may result in a risk of electrical shock, fire, death, or serious injury.

EXPLOSION HAZARD:

It is normal for the inverter to arc during the final wiring connection. Do not use the inverter in an environment where flammable fumes or gases are present (such as gas bottles).

LIMITATIONS OF USE:

Do not use in connection with life support systems or other medical equipment / devices.

iTECHWORLD

THE POWER EXPERT

CONTACT US



1300 483 249



service@itechworld.com.au



www.itechworld.com.au

When it comes to energy storage and creation at iTechworld, we take pride in being one of the biggest names in the industry. Based in Australia, we are a family-owned and operated business. With many more innovative products on the horizon we are committed to constantly raising the bar to provide bigger and better benefits to all our customers Australia-wide.

Whether you're an avid camper, 4WD enthusiast, freedom seeker or camper, we've got your power needs covered. Escape the grid without compromise, minimise your downtime and travel with comfort with our large range of leading products at great prices.

iTechworld. The Power Expert.

LOVE YOUR iTECHWORLD INVERTER? **LEAVE A REVIEW**

