

RESIDUAL CURRENT MEASUREMENT DEVICE

RCM 202-AB

(from Firmware V1.3.0)

Installation Instructions

Art. No. 33.03.388 Doc. No. 2.002.145.1.a 09/2021



User manual:



Janitza®

Janitza electronics GmbH
Vor dem Polstück 6
35633 Lahnu, Deutschland

1 Information about using this user manual

1.1 General information

This user manual is intended exclusively for use by trained specialized electro-technical personnel.

This user manual is a part of the product and makes reference to other devices from Janitza electronics GmbH. Only the names of the respective device series are specified, but not all the associated types. Read this user manual before using the device. Observe all safety requirements and warning notices. Failure to observe the instructions can lead to personal injury and/or damage to the product.

Keep the user manual through the entire service life of the product so it is available for all users.

For this quick start, please also note further documentation on our homepage, such as

- user manual and safety instructions

INFORMATION

Further information - e.g. the user manual - can be found in the download area at www.janitza.com.

2 Safety instructions

2.1 Symbols used

Safety information in the installation instructions is marked by a warning triangle and, in dependence on the degree of hazard, is displayed as follows:

DANGER

Warns of an imminent danger which, if not avoided, will result in serious or fatal injury.

WARNING

Warns of a potentially hazardous situation which, if not avoided, could result in serious injury or death.

CAUTION

Warns of an immediately hazardous situation which, if not avoided, can result in minor or moderate injury.

ATTENTION

Warns of an immediately hazardous situation which, if not avoided, can result in material or environmental damage.

INFORMATION

Indicates procedures in which there is no hazard of personal injury or material damage.

2.2 General safety instructions

The following safety instructions must be observed for work on and with the RCM 202 AB. Specific safety instructions are also listed in the respective chapters.

DANGER

Danger of electric shock!

Electric shocks lead to serious injuries, including death.

- All work necessary for the connection, assembly, commissioning and operation of the device may only be performed by well trained and instructed specialist personnel.
- The specialist personnel must observe and comply with the relevant applicable standards and directives for work on electrical systems (e.g. DIN EN 50110 and ff./ directives and regulations of professional associations in Germany).
- Disconnect your system from the power supply before mounting and connecting the device!
Secure it against being switched on!
Check to be sure it is de-energized!
Ground and short circuit!
Cover or block off adjacent live parts!

ATTENTION

Use of the device requires sufficient knowledge of the product as well as knowledge about the connected devices and systems. Changes to the preset values and control commands influence the evaluation behavior of the residual current measurement device. Therefore changes to the commissioning settings as well as the replacement of devices may only be carried out upon agreement with Janitza electronics GmbH!
Changes carried out are to be documented in the system documentation!

INFORMATION

The RCM 202-AB is supplied as a component of a residual and operating current monitoring system. Upon commissioning/delivery of a monitoring system, all system-specific settings and control commands for the RCM 202-AB shall be parameterized and documented by Janitza electronics GmbH.

3 Purpose – Intended use

The RCM 202-AB is a two-channel residual current measurement device for the measurement and monitoring of main distribution boards up to a maximum residual current of 20A. With connected current measurement transformers (also current sensors), the RCM 202-AB is used for the measurement and monitoring of residual currents in TN and TT systems (grounded AC systems).

With additional devices of the RCM series, display devices or devices for data coupling to third-party systems, it forms a complete residual and operating current monitoring system. This monitoring system increases system and operational safety. Faults or an increase in residual currents (usually creeping) are detected early on, for example, thus allowing preventative maintenance. The external signal current circuits used in the monitoring system shall be secondary current circuits.

Any use of the RCM 202-AB that differs from the description in this manual is considered improper use and may affect the protection provided by the device.

4 Overview of the RCM 202-AB

4.1 Device view

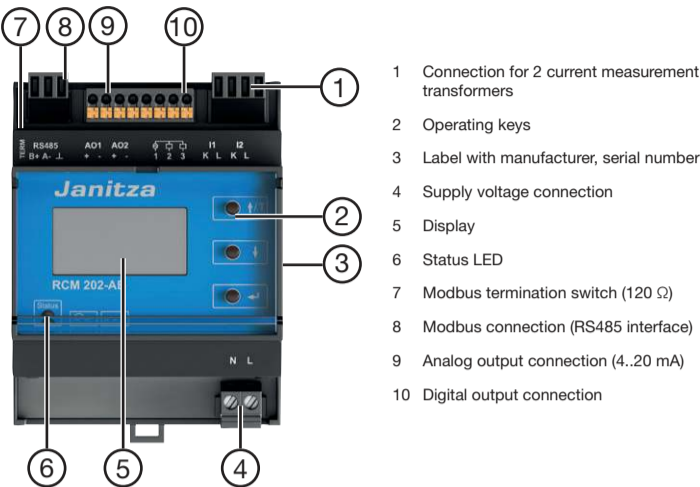

Fig. 1: RCM 202-AB device view

4.2 Device dimensions

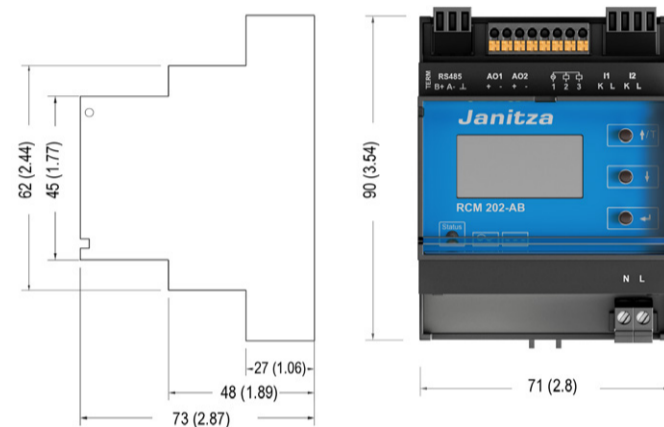

Fig. 2: Device dimensions in mm (in)

5 Functions

5.1 Basic functionality

The main functions of the RCM 202-AB are:

- Residual current measurement via a connected current measurement transformer (max. 2 current measurement transformers)
- Transformer connection monitoring for wire breaks or short circuit per channel
- Effective value measurement (true RMS)
- Parallel measured value recording
- Evaluation of fault currents (residual currents) type A and B according to IEC 62020
- Detection of sinusoidal residual fault currents with frequencies up to 20kHz (type B+)
- Measured value and extreme value storage with time stamp
- Parameterizable alarm threshold for alarm message per channel
- Parameterizable warning threshold (e.g. prewarning) for warning message per channel
- Parameterizable delay times (Delay time for warning and alarm messages, Reset delay time for warning and alarm messages)
- Operating and error messages shown on the display
- Communication via Modbus (RS485 interface/Modbus RTU)
- Evaluation possibility with the help of the GridVis® monitoring system or a display and evaluation device

5.1.1 Residual current monitoring principle

The fault currents (residual currents) flowing to ground or other paths are recorded via the connected current measurement transformers.

For example:

- Outflow-related residual currents (consumers and systems)
- Stray currents in TN-S systems (PEN and N conductors)

ATTENTION

Do not route the PE conductor through the current measurement transformer!

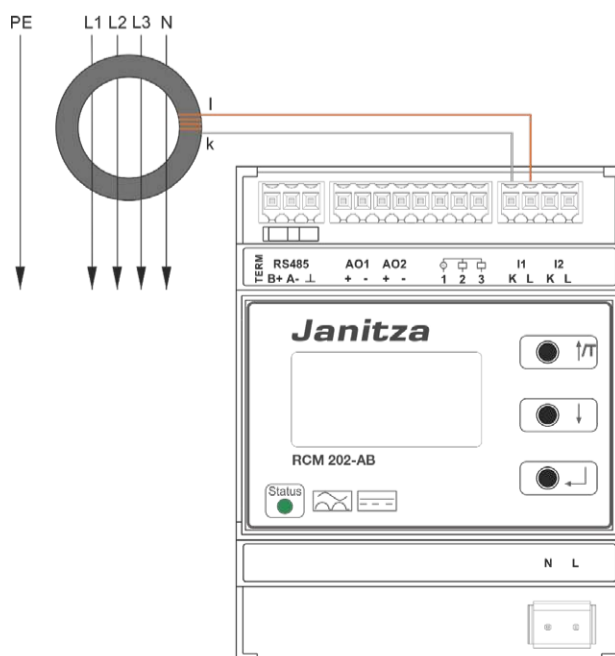

Fig. 3: Simplified presentation of residual current measurement

5.1.2 Current measurement transformer monitoring

The RCM 202-AB evaluates currents from up to two current measurement transformers at the same time. For each active channel, the RCM 202-AB continuously checks the connected transformer for short circuit or wire breaks. If a short circuit or wire break occurs on the transformers, an error message is output on the display as well as on the communication interfaces and the status LED flashes red.

5.2 RS485 interface (Modbus)

The RCM 202-AB has a Modbus interface (RS485) and works with the Modbus RTU protocol as a slave. The device address 1 and the baud rate of 19200 baud are factory-set.

For more information, see the user manual at www.janitza.com

WARNING

Risk of injury due to high currents and high electrical voltages!

Severe bodily injury or death can result from: Touching bare or stripped leads that are energized. The current measurement inputs of the device and at the current transformers are dangerous live. The open ground connection of the RS485 interface may not be touched! There is a risk of electric shock.

Therefore, please note for your system:

- Disconnect the supply of power before starting work!
- Secure it against being switched on!
- Check to be sure it is de-energized!
- Ground and short circuit! Use the ground connection points with the ground symbol for grounding!
- Cover or block off adjacent live parts!
- The power supply connection and the transformer connections of the RCM 202-AB may be switched on only after connecting the ground terminal and grounding the ground cable.

5.3 Digital outputs

WARNING

Transmission errors and damage to property due to electrical faults

If the line is longer than 30 m, there is an increased probability of transmission errors and damage to the device due to atmospheric discharge.

- Use a shielded cable for connection to the digital inputs and outputs.

WARNING

Material damage due to connection errors.

The digital outputs are not short-circuit proof! Connection errors can therefore lead to damage to the connections.

- Make sure that the wiring is correct when connecting the outputs.

The RCM 202-AB has two transistor switching outputs. These digital outputs are electrically isolated from the evaluation electronics via optocouplers.

- The digital outputs switch direct current or alternating current loads.
- The digital outputs switch loads independently of the polarity of the supply voltage.

5.4 Analog outputs (interfaces 4 ... 20 mA)

The RCM 202-AB has two analogue outputs (interfaces 4 ... 20 mA). The analogue outputs output the effective value of the measured total current. Both analogue outputs require a separate power supply (DC 12 ... 24 V).

Further information can be found in the user manual at www.janitza.com

6 Connection assignment

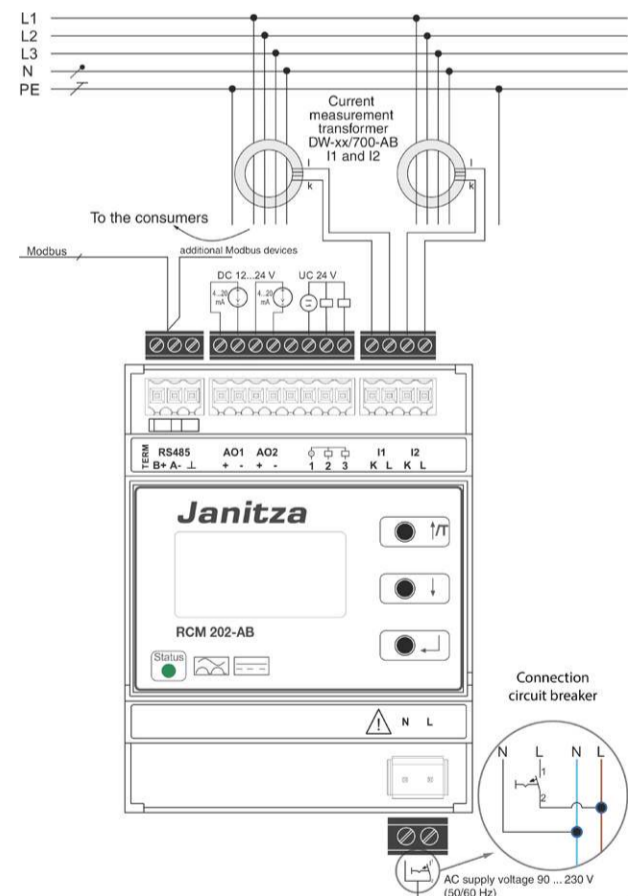

Fig. 4: Circuit diagram of the RCM 202-AB

Modbus (RS485 interface)		
Pin	Designation	Meaning
1	B+	D+/non-inverted signal
2	A-	D-/inverted signal
3	⊥	Reference potential (GND)
Analog and digital output connection		
1	AO1+	Analog output 1 (4 ... 20 mA sink +)
2	AO1-	Analog output 2 (4 ... 20 mA sink -)
3	AO2+	Analog output 3 (4 ... 20 mA sink +)
4	AO2-	Analog output 4 (4 ... 20 mA sink -)
5	-	-
6	1	Common connection for both digital outputs
7	2	Digital output 1
8	3	Digital output 2
Current measurement transformer connection		
1	I1 - K	Current measurement transformer 1, contact k (wire color ¹⁾ : white)
2	I1 - L	Current measurement transformer 1, contact l (wire color ¹⁾ : brown)
3	I2 - K	Current measurement transformer 2, contact k (wire color ¹⁾ : white)
4	I2 - L	Current measurement transformer 2, contact l (wire color ¹⁾ : brown)

1) for transformers with fixed connection cables without contacts k and l

Power supply connection		
1	N	Supply voltage AC 90 ... 230 V (N)
2	L	Supply voltage AC 90 ... 230 V (L)

Tab. 1: Connection assignment RCM 202-AB

Bus termination		
TERM switch	Switch position	Resistance
On (first and last bus participant)	RH	Resistance (120 Ω) switched on
Off	left	No resistance

Tab. 2: Bus termination via the TERM switch

7 Application example

7.1 Application example RCM 202-AB in stand-alone mode

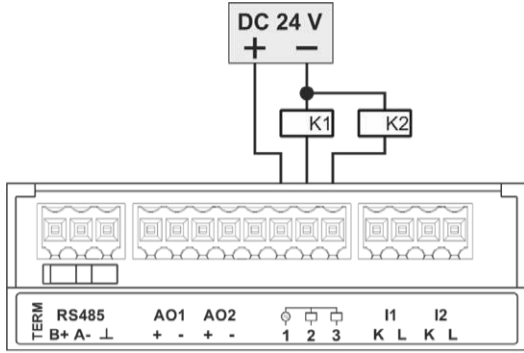

Fig. 5: Connection of two relays to the digital outputs

7.2 Application example analog outputs (interface 4...20mA)

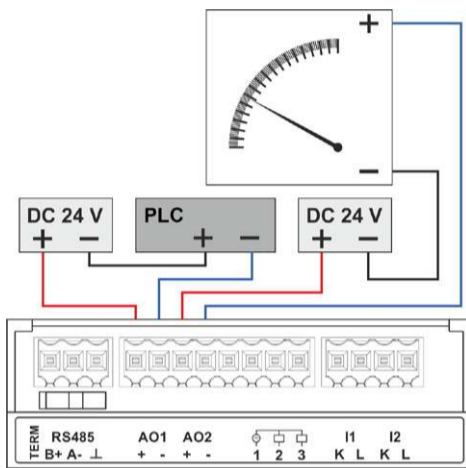

Fig. 6: Connection of a display device and a PLC to the analog outputs (Power supply: Janitza power supply unit, art. no. 16.05.012)

7.2.1 Application example analog outputs and UMG 96RM-E

The analogue outputs (AO1/AO2) may only be operated on galvanically isolated inputs/devices. Use a maximum of ONE analogue measurement circuit per measurement device (e.g. UMG 96RM-E) for the RCM 202-AB. Using TWO analogue channels between the RCM 202-AB and a device without galvanically isolated inputs leads to measurement errors.

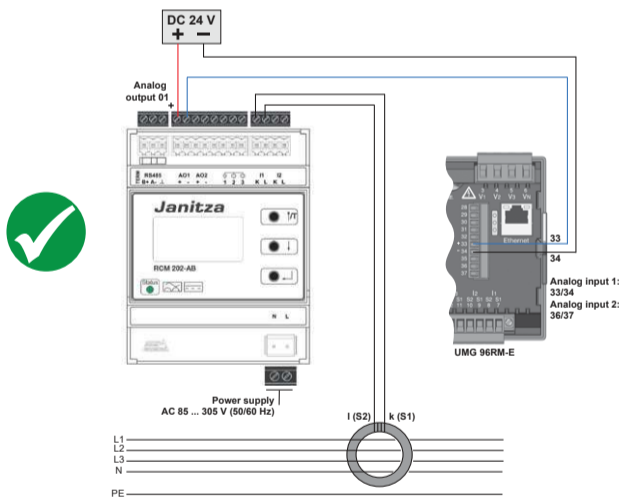

Fig. 7: Connection to the analogue inputs of a UMG 96RM-E

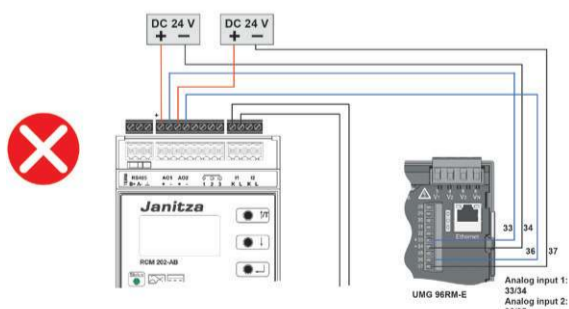

Fig. 8: Invalid connection scheme

7.3 Application examples via Modbus (RS485 interface)

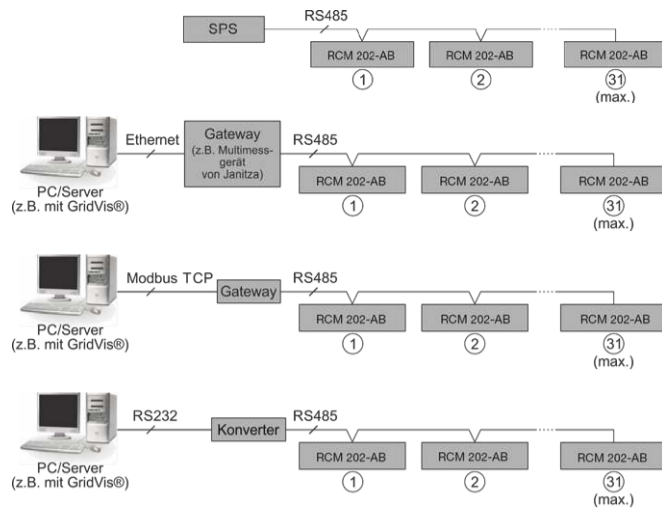

Fig. 9: Application examples

8 Assembly, commissioning and configuration

ATTENTION

Assembly, connection and commissioning may only take place through qualified electrical personnel in compliance with the existing safety regulations and standards. A line circuit breaker must be installed for the power supply of the RCM 202-AB. After commissioning, the connectors of the device must be protected against accidental contact by a cover if it is not ensured that only qualified personnel have access to the device.

INFORMATION

Site information (e.g.: device designations), the installation in the Modbus segment, the serial number, the Modbus address (device address) as well as the designation of the current measurement transformer must be noted in the system documentation or taken from the supplied system documentation.

8.1 Assembly (initial installation)

The RCM 202-AB is installed in distribution boards and switchgears on a top hat rail (35 mm) according to DIN EN 60715.

Requirements: The current measurement transformers are already installed on the cables to be monitored.

- 1 Visually check the RCM 202-AB for damage.
- 2 Snap the RCM 202-AB onto the top hat rail.
- 3 Check the RCM 202-AB for tight fit.
- 4 Connect the plug of the RS485 interface to RCM 202-AB. Connect the ground connection of the RS485 interface 1 with the protective conductor PE.

INFORMATION

The device address 1 and the baud rate of 19200 baud are factory-set. If the RCM 202-AB is the first or last device in the Modbus line, the termination resistor must be set. The ground terminals of all RS485 connections of multiple RCM 202-AB must be connected with the ground wire of the cable. The ground wire must be grounded in one point. The second wire pair of the bus cable is used as the ground wire. Both wires of the pair are parallel connected. The shield may be applied only on one side!

- 5 Terminate the first and last bus participants within a bus segment by pushing the "Term" switch to the right.

INFORMATION

In the case of a RS485 connection from a control cabinet to a control cabinet, the Modbus connections B+ and A- must be electrically isolated.

- 6 Connect the current measurement transformer to the plug of the respective current measurement input (I1 and I2). When doing so, observe the connections K and L (see user manual).
- 7 Connect the analog and digital outputs if necessary.
- 8 Make sure that the connected connectors are still firmly seated.
- 9 Retighten all screw connections.

8.2 Commissioning

INFORMATION

The housing of the RCM 202-AB warms up during operation.

- 1 Connect the plug for the power supply to the N/L connection. The status LED flashes green. RCM 202-AB initialization takes place. "I1=---" and "I2=---" appear on the display.
- 2 Wait until initialization is completed. Initialization can take up to 60 seconds. Initialization will take longer if the transformer measures residual currents already during initialization. The status LED lights up green and the measured values for the activated measurement channels are shown on the display. The RCM 202-AB is ready for operation.
- 3 If necessary, configure the RCM 202-AB (see user manual) according to the system to be monitored and depending on the circuit of its connections.

INFORMATION

The system documentation must be observed for the parameterization of the RCM 202-AB.

9 Technical Data

9.1 General technical data

Operating data	
Supply voltage U_s	AC 90...230V, 50/60Hz
Required external back-up fuse for the power supply	Circuit breaker 1 pole, 3 A, AC 230 V
Operating mode	Continuous operation
Power consumption (internal consumption)	8 W
Isolation coordination according to IEC 60664-1	
Rated current I_b	4 kA
Rated surge voltage	4 kV
Pollution degree	2
Rated voltage	AC 250 V, 50 ... 60 Hz
Monitored system	
Measurement transformer types/transformation ratio:	
Residual current measuring transducer	see Tab. 3

Current measurement transformer rated voltage	AC 20 ... 720 V
Current measurement transformer rated frequency	0 ... 20 kHz
Current measurement transformer rated current	(depending on type)
Measurement channels	
Number of measuring channels	2 (connectable current measurement transformers)
Measured value recording	Parallel, effective value measurement (true RMS)
Evaluation	Residual currents Type A and B according to IEC 62020
Measurement response residual current $I_{\Delta n}$	Parameterizable, 20 mA ... 20 A
Response delay time of the warning and alarm messages t_v	Parameterizable, 10 ms ... 10 s
Reset delay time t_{vr}	Parameterizable, 10 ms ... 10 s
Transformer connections	
Connection to the current measurement transformers	Line resistance max. 2 Ω
Line/transformer	2-wire
Line length	
Single wires (0.75 to 1.5 mm ²)	max. 1 m
Twisted single wires (0.75 to 1.5 mm ²)	max. 10 m
Shielded cable (0.75 to 1.5 mm ²)	max. 10 m
Displays, messages and memory	
Full graphics display (LCD)	128 x 64 pixel with backlight
Status LED	3-color
Controls	3 keys
Menu languages	German, English, Spanish
Date and time	With RTC, stored in the non-volatile memory
Parameterization	On RCM 202-AB in the configuration menu
Messages	Display, LED, Modbus, digital outputs
Measured value memory	18,725 datasets (circular buffer) With date and time
Examples	
Shielded cable 0.75 mm ² (shield on I)	Max. length 20 m (21.87 yd)
Cable type J-Y(STY) Ø 0.6 mm	Max. length 15 m (16.4 yd)
Analog outputs	
Interface	4 ... 20 mA
Quantity	2
Supply voltage of the analog outputs	DC 12 ... 24V
Digital outputs	
Number of digital outputs	2
Switching voltage	max. DC 60V, AC 30V
Maximum current	350 mA
Start-up resistance	2 Ω
Maximum cable length	up to 30 m (32.8 yd) unshielded, above 30 m (32.8 yd) shielded
RS485 interface	
Protocol	Modbus RTU (RCM 202-AB as the slave)
Interface	RS485
Baud rate	Parameterizable, 9.6 ... 115.2 kbaud
Address range	1 ... 247
max. cable length (38.4 kbaud)	1200 m (1212.3 yd)
Cable (shielded, shield one-sided on PE)	Unitronic Li2YCY(TP) 2x2x0.22 (Lapp cable)
Termination resistor	120 Ω (can be activated on the device)

Device safety	
Safety regulations for electrical measurement, control, regulation and laboratory devices	
Part 1: General requirements	IEC/EN 61010-1
Part 2-030: Particular requirements for equipment having testing or measuring circuits	IEC/EN 61010-2-030
Electromagnetic compatibility (EMC)	
Immunity from interference	
Class A: Industrial sector	IEC/EN 61326-1
Electrostatic discharges	IEC/EN 61000-4-2
Voltage dips	IEC/EN 61000-4-11
Emissions	
Class B: Residential sector	IEC/EN 61326-1
RFI field strength 30 ... 1000 MHz	IEC/CISPR11/EN 55011
Radiated interference voltage 0.15 ... 30 MHz	IEC/CISPR11/EN 55011
Standards	
The RCM 202-AB fulfills the requirements according to EN 62020:1998+A1:2005 (VDE 0663):2005	
Ambient conditions	
Ambient temperature during operation	-5 ... +55°C (23°F...131°F)
Ambient temperature during storage	-25 ... +70°C (-13°F...158°F)
Ambient temperature during transport	-25 ... +70°C (-13°F...158°F)
Altitude	0 ... 2000 m (0 ... 1.24 mi)
Climate category according to IEC 60721-3-3 (operation)	3K5
Installation conditions	
Installation position	Horizontal/vertical
Assembly	Top hat rail per DIN EN 60715
Device dimensions in mm (H x W x D)	71 x 90 x 73
Protection class according to EN 60529	IP 20
Protection class	II
Flammability rating	UL94V-0
Weight	Approx. 170 g (0.375 lb)
Connection type/cable	Series terminal/copper
Connection cross section single-wire/finely stranded	0.2 ... 4 mm ² /0.2 ... 1.5 mm ² (AWG 24-15)

The following current measurement transformers can be connected to the RCM 202-AB:

Transformer type	Inner window (mm)	Separable	Transformation ratio	Max. primary current (mA)
DACT20	20	-	600:1	18000
CT-AC RCM 35N	35	-	700:1	20000
CT-AC RCM 80N	80	-	700:1	20000
CT-AC RCM 110N	110	-	700:1	20000
CT-AC RCM 140N	140	-	700:1	20000
CT-AC RCM 210N	210	-	700:1	20000
CT-AC RCM A110N	110	•	700:1	20000
CT-AC RCM A150N	150	•	700:1	20000
CT-AC RCM A310N	310	•	700:1	20000
KBU 23D	20 x 30	•	600:1	18000
KBU 58D	50 x 80	•	600:1	18000
KBU 812D	80 x 120	•	600:1	18000
W1-S35	35	-	600:1	18000

Tab. 3: Current measurement transformer for RCM 202-AB

Janitza®

Janitza electronics GmbH
Vor dem Polstück 6 • 35633 Lahnau, Deutschland
Support Tel. +49 6441 9642-22 • E-Mail: info@janitza.de • www.janitza.com