



Control 10C-VA Series Ceiling Loudspeakers

Control 12C-VA, Control 14C-VA, and Control 16C-VA

Owner's Manual & Installation Guide

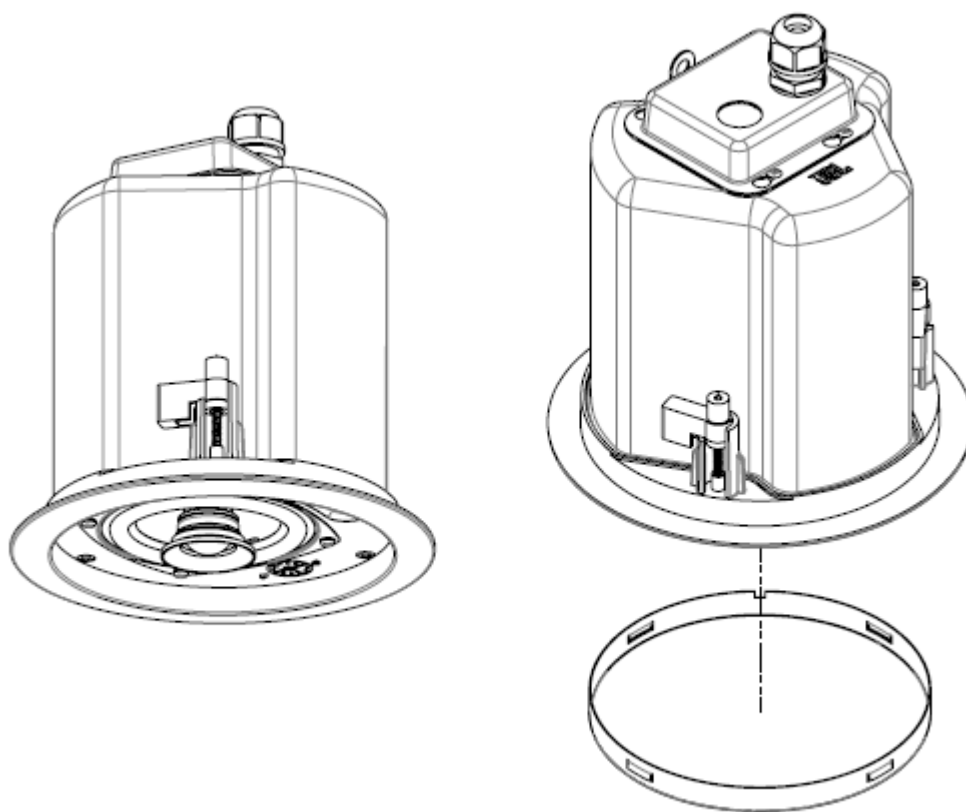
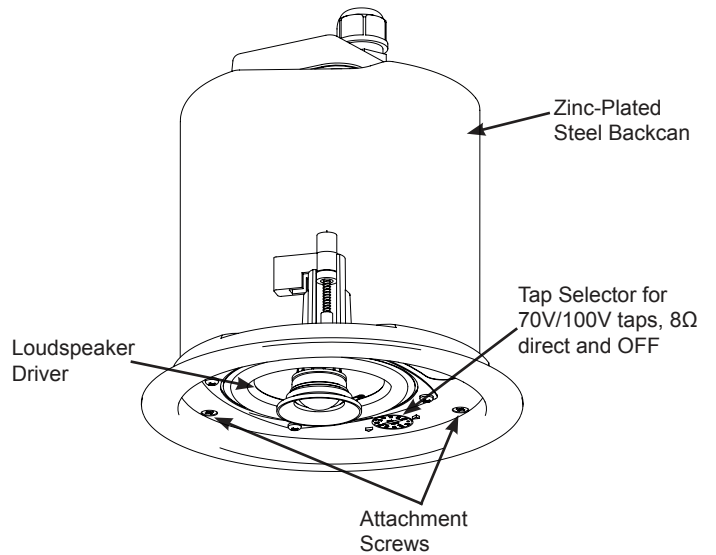

Table of Contents

- Product Description 2
- Product Feature Identification 2
- Installation Preparations 3
- Step-By-Step Installation and Wiring 3
- Painting the Speaker 7
- Safety Agency Compliance 8
- Maintenance 8
- Replacement Parts 8
- Contacting JBL 8
- Product Specifications 9

Product Feature Identification

(Control 14C-VA Shown)



Thank you for purchasing JBL Control Contractor ceiling loudspeakers. Read through this manual to familiarize yourself with the features, applications and precautions before you use these products.

Product Descriptions

The JBL Control Contractor Control 10C-VA Series of EN54-24 certified ceiling loudspeakers utilize innovative design and materials to provide premium level performance from compact in-ceiling speakers.

CONTROL 12C-VA – A 3” (75 mm) full-range driver to provide high-fidelity full-range sound over an extremely wide coverage area.

CONTROL 14C-VA – A wide bandwidth ceiling speaker containing a co-axially mounted 4” (100 mm) woofer and ¾” (19 mm) soft-dome tweeter.

CONTROL 16C-VA – A wide bandwidth, high sensitivity, extended bass ceiling speaker containing a co-axially mounted 6.5” (165 mm) woofer and ¾” (19 mm) soft-dome tweeter.

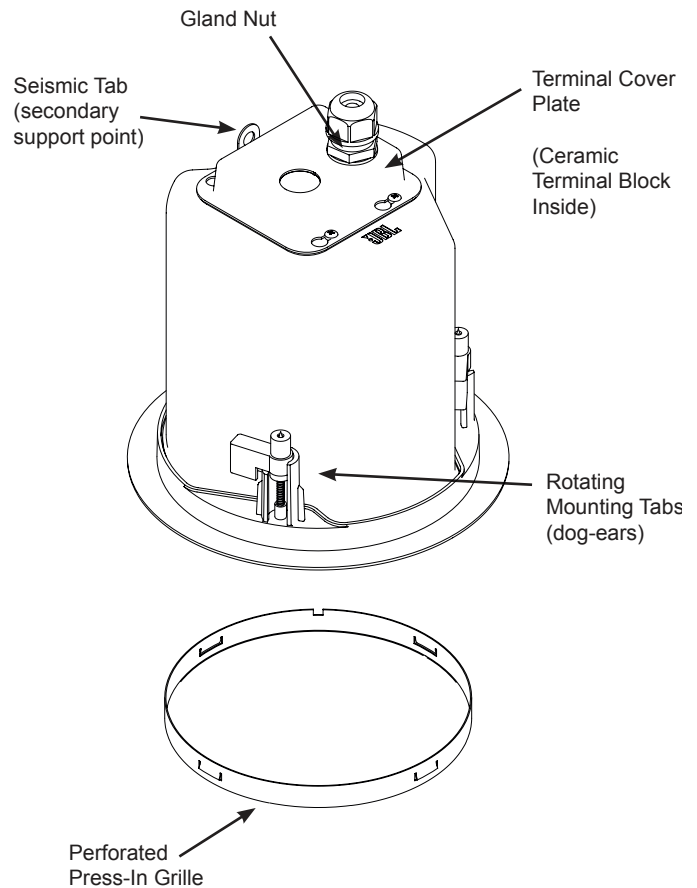

Installation Preparations

The entire installation can be accomplished, if necessary, without requiring access above the ceiling. Bracketry for use with either suspended ceilings or sheetrock ceilings is included. The speaker is held securely in place via mounting ears which lock into place.

OPTIONAL PRE-INSTALLATION BRACKETS

IN MOST CASES, NO BRACKETS OTHER THAN THE ONES INCLUDED WITH YOUR SPEAKER ARE REQUIRED. Everything needed for most installations of these loudspeakers is provided with your Control Contractor ceiling speaker.

However, when the speaker is being installed into a sheet rock (typically gypsum board) ceiling, JBL's optional pre-installation brackets can be installed before the sheetrock is installed. The pre-installation bracket provides a bracket to which wiring can be tied behind the sheetrock. It can function as a cutout template when many cutouts are to be made in a production-line style installation, and it secures the ceiling speaker to the building structure. Two types of pre-installation brackets are available from JBL Professional as optional accessories:

1) The optional **NEW-CONSTRUCTION BRACKET** is made of flat sheetmetal, with wings to attach to the building structure. Holes are drilled for nails or screws at 16 inches (406 mm) and 24 inches (610 mm) on-center. Additional holes can be drilled by the installer at other spacings up to a maximum of 24-3/4 inches (630 mm) apart. Sheet rock installs over the bracket, and the bracket provides a template for blind cutout of the hole in the sheet rock. The sheet rock is typically cut with a router-type cutting tool, using the bracket ring as a cutout guide.

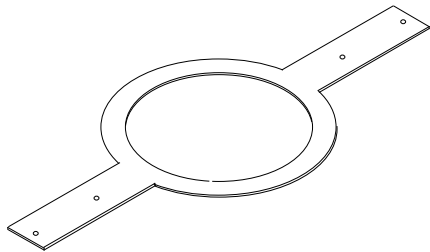

Figure 1:
Optional NC New-Construction Bracket

2) The optional **PLASTER-RING BRACKET** (or “mud ring”) contains a circular offset, forming an edge guide for sheet rock plastering. The bracket has wings that attach to the building structure. Sheet rock is typically either pre-cut or cut with a rotary cutting tool using the outside of the plaster ring circle as a guide. The sheet rock hole is then plastered (or “mudded”) up to the ring to create a seamless cutout.

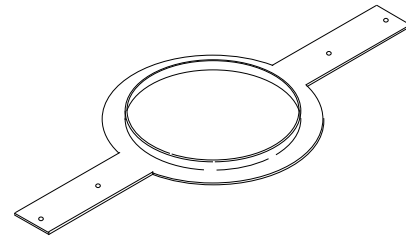

Figure 2:
Optional MR Plaster-Ring Bracket (“Mud Ring”)

Table 1: New Construction Brackets

Model	New Construction Bracket	Plaster-Ring Bracket
Control 12C-VA	MTC-24NC	MTC-24MR
Control 14C-VA	MTC-24NC	MTC-24MR
Control 16C-VA	MTC-26NC	MTC-26MR

USING INCLUDED C-BRACKET WITH SHEET-ROCK

For most installations, the INCLUDED C-shaped backing plate provides adequate reinforcement to the ceiling material, spreading out the clamping force from the tab clamps.

CUTOUT SIZES

Table 2: Cutout Sizes

Model	Cutout Size (diameter)
Control 12C-VA	167 mm (6.7 in)
Control 14C-VA	167 mm (6.7 in)
Control 16C-VA	225 mm (8.8 in)

STEP-BY-STEP INSTALLATION AND WIRING

The installation system has been designed so that the entire installation can be accomplished from beneath the ceiling for instances when access above the tile is not possible or practical. However, in some cases it may be easier with removable ceiling tiles to access from both the top and bottom of the ceiling tile during various phases of the installation.

Step 1 – Cut the Hole in the Ceiling Material. Cut-out the circular hole to the cutout hole size listed above. Pull the wiring through the cutout hole.

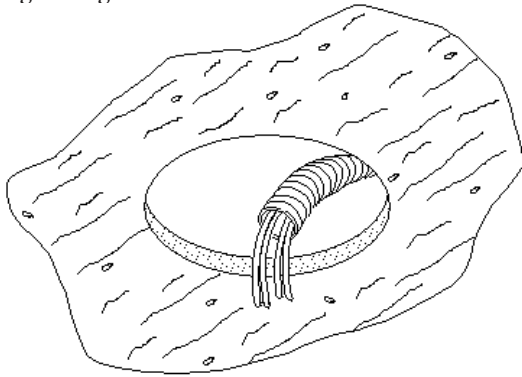

Figure 3:
Hole Cutout

Step 2 – Insert Backing Hardware Through the Hole. Packaged with the speakers are two types of backing hardware – a C-shaped backing-plate bracket and two tile rails.

Suspended Ceilings – Insert the C-plate through the hole cut in the ceiling tile. Place the C-plate around the hole with the tabs located as shown on Figure 4. Insert the tile rails through the cut hole in the ceiling tile. Snap the two rails into the two tabs in the C-plate and align the rails so that the ends extend OVER the T-channel grid on the side of the tile. Secure the rails onto the C-bracket tabs by inserting a screw through each tab into the rail. This can all be accomplished from below the ceiling tile, if necessary.

FOR SAFETY:
IMPORTANT TO USE BRACKETS
ALL included support brackets – C-plate and tile rails -- MUST be used when installing into suspended ceiling tiles.

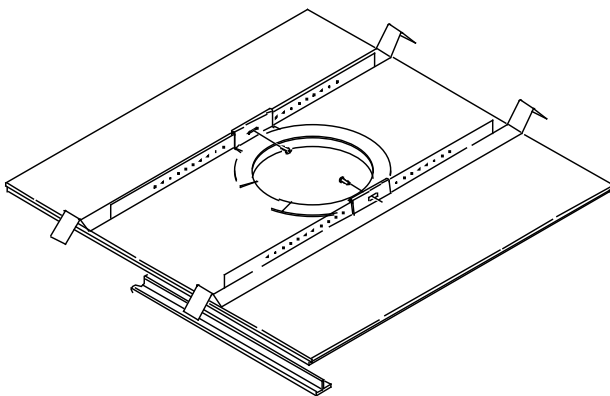

Figure 4:
C-Bracket and Tile Rail Positioning on Ceiling Tile

Additional Suspended Ceiling Installation Information

Tile Rails: The tile rails are designed to fit either standard 24-inch wide tiles or 600-mm wide tiles. The tile rail pieces do NOT physically attach to the T-grid struts. Instead, the inverted-V shape at the ends of the rails sit OVER the T-grid strut. During normal operation, the rails are supported by the edge of the tile. If the tile were to come out or fall apart, the ends of the support rails are designed to catch onto the T-grid, providing secure support to hold the loudspeaker assembly in place.

Vibration Reduction: Loudspeakers can generate substantial vibration which can cause buzzing of the ceiling materials or structure. Depending on the character of the ceiling tile and structure, the installer might need to place neoprene or other dampening material under the tile rails or the edges of the tiles to eliminate rattles.

Cutout Placement: The tile rails are pre-punched with attachment holes along their length. Placement is not limited to the center of the tile as is the case with many other tile rail support systems.

Non-Suspended Ceiling Types – The C-bracket can be optionally used by itself to shore up the ceiling material and to spread out the clamping force from the tab clamps. Insert the C-plate through the cut hole in the ceiling and place it on the back side of the hole before inserting the speaker.

Step 3 -- Removing Terminal Cover. Loosen the 4 screws holding the Terminal Cover Plate (you do not have to remove them), slide the plate to where the screws line up with the larger end of the keyholes, and remove the Terminal Cover Plate.

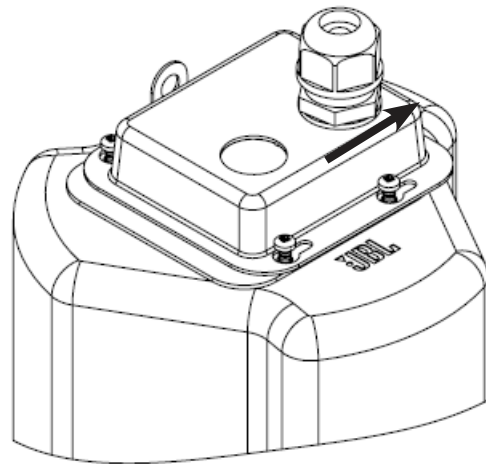

Figure 5:
Loosening the four set screws holding the Terminal Cover Plate and removing the plate.

Make sure the gland nut fitting is affixed and tightened in the proper knock-out location (add a second gland nut to the other knock-out location if two glands nuts are desired). Slide the wire through the gland nut (do not tighten the gland nut onto the wire yet).

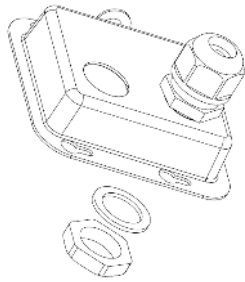

Figure 6:
Affixing gland nut to Terminal Cover Plate

Step 4 – Connect the Wiring to the Ceramic Terminal Block

The Ceramic Terminal Block is attached to the speaker. Strip the insulation back about 5 mm (about 3/16 inch). Do NOT strip wires back any longer than this. Insert the bare end of wire fully into the connector (not allowing any bare wire outside of connector). Only utilize the side of the terminal where there aren't already wires connected.

Add a second set of wires in parallel to the same terminals if a second wire is utilized for looping to another loudspeaker. Screw down the hold-down screw until tight using a small phillips-type screwdriver. Tighten any unused screws to avoid rattling from vibration.

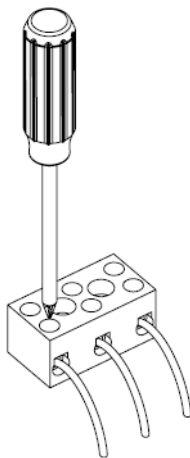

Figure 7:
Connecting Wires to the Ceramic Terminal Block

(Note that the right-hand wire shown in diagram is optional. It only needs to be connected if the chassis of the driver needs to be connected to a safety ground.)

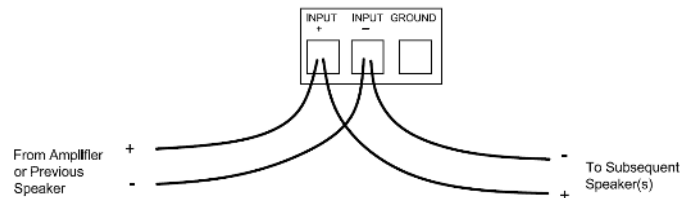

Figure 8:
Connecting two sets of wires to the Ceramic Terminal Block for loop-out to a subsequent loudspeaker

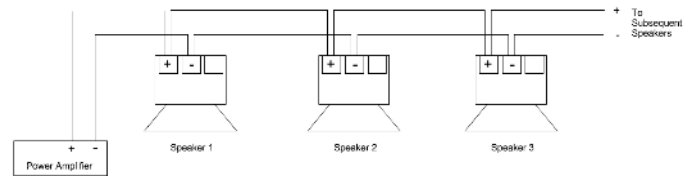

Figure 9:
Paralleling connections to multiple speakers for 70V or 100V distributed speakers systems

Guide to the Pins for Connection -- The Ceramic Terminal Block contains 3 terminals, as marked on the connector as + INPUT, - INPUT and GROUND.

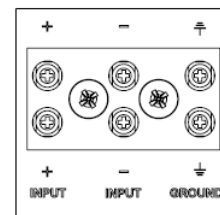

Figure 10:
Terminals

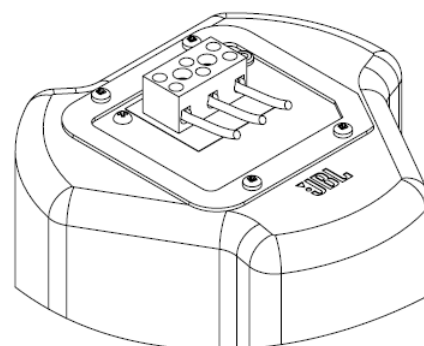

Figure 11:
Shown wired (without cover shown)

Step 5 – Re-attach Terminal Cover Plate and Tighten Gland Nut -- Slide the wire through the gland nut until you can re-attach the Terminal Cover Plate. Install the cover plate so that the screws go in through the keyholes, and slide the plate so that the screws are back at the narrow-slot end of the keyholes. Tighten the 4 screws. Tighten the gland nut onto the wire (leaving enough slack inside the coverplate so that there is no strain on the wires inside the compartment).

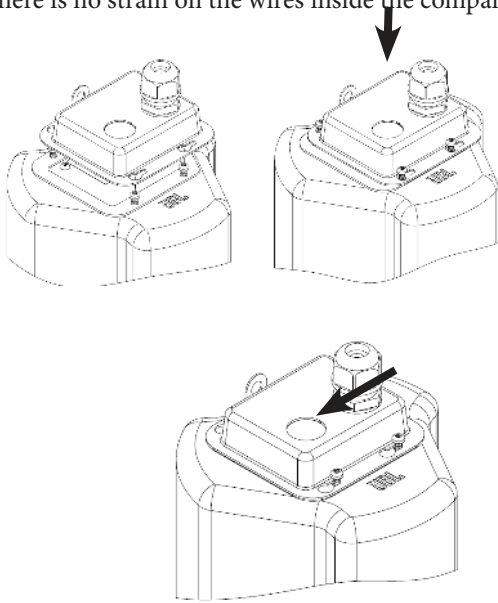

Figure 12:
Re-attaching Terminal Cover Plate

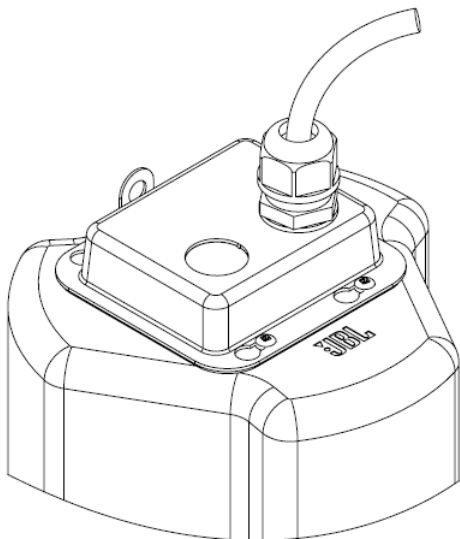

Figure 13:
Shown wired with Terminal Cover Plate
in place

Step 6 – Insert Speaker into Ceiling & Tighten– Insert the speaker into the ceiling as far as it goes, until the front baffle rim touches the ceiling.

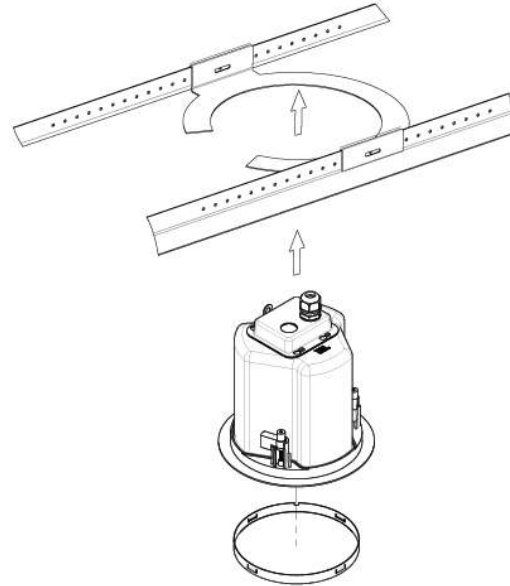

Figure 14:
Inserting Speaker into Ceiling

(C-ring/tile-rail assembly is above the ceiling tile. Speaker inserted through cutout in ceiling material. Diagram shown without cable and ceiling tile for clarity)

Turn the attachment screws to tighten the mounting tabs, by using the following directions:

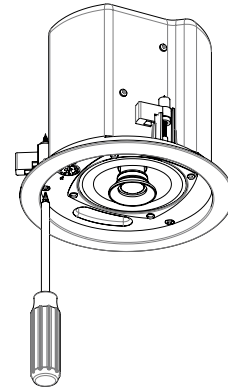

Figure 15:
Tightening Mounting Tabs

IMPORTANT -- For each attachment screw, **FIRST** turn $\frac{1}{2}$ turn **COUNTER-CLOCKWISE** to release the mounting tab from its guide.

Then tighten the mounting tabs by turning the screw **CLOCKWISE** until tight. The first $\frac{1}{4}$ clockwise turn rotates the attachment tabs outward and the remaining turns tighten the tabs down onto the back of the ceiling surface. **DO NOT OVERTIGHTEN.**

A tab is provided on the back of each speaker for connection to an independent secondary support point. Some construction codes require using this secondary support point, which requires connecting a support line to a separate secure support point on the building structure. Consult construction codes in your region.

IMPORTANT -- Control Contractor ceiling speakers can generate substantial vibration. Using the seismic tab as a secondary support point is highly recommended in case the ceiling tile or structure breaks. In some areas, using the seismic tab as a secondary support point is required by code.

Step 7 Adjust Tap Selector – The tap selector rotary switch is located on the front baffle. Adjust the tap setting **before** applying power to the speaker and before inserting the grille. From the OFF position, turn the selector counter-clockwise to set to the 8Ω (low impedance) nominal setting (see spec sheet for more precise impedance information) or turn the selector clockwise to set to the various 70V and 100V distributed system tap settings.

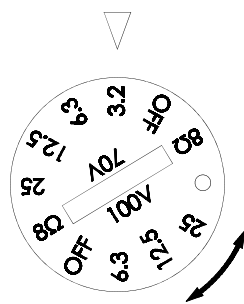

Figure 16:
Tap Selector
(Shown: Control 14C-VA. Tap ratings on the other models differ from these figures.)

Step 8 – Insert the Grille – After testing the speaker, consider which direction the logo is facing and press the grille into place until the front of the grille is flush with the rim. It is often easiest to press in various places around the perimeter of the grille. Make sure grille is securely seated to prevent it from vibrating loose and falling.

Removing the Grille -- The grille presents a tight fit in order to make sure that it won't fall out, even with high vibrations that can be produced by these speakers. If you need to remove the grille, it is easiest to do so by inserting 2 pointed objects (such as push pins) into 2 nearby holes in the grille, presenting slow even pressure to pull down on the grille until that section of the grille comes out approximately 6 mm (1/4 inch). Work your way around the grille, loosening a section at a time until the grille comes out.

Painting the Speaker

For EN54 Applications -- Painting is not allowed for EN54 applications, under the general requirements for EN54-certified loudspeakers.

For Non-EN54 Applications -- The speaker's textured white finish complements most decor and does not need further finishing. Where the interior design requires it, these speakers are easy to paint.

The rim can be painted before installation or in cases where the rim needs to be finished along with the ceiling, the speaker rim can be painted after attaching into the ceiling.

Type of Paint – The speaker's ABS rim accepts almost any type of latex or oil based paint. Two coats are recommended.

Painting Process – For best results, the following procedure is recommended:

- Clean the rim and grille with a light solvent such as mineral spirits by rubbing the item with a lightly dampened cloth. Do not, however, use abrasives such as sandpaper or steel wool. Nor should you use gasoline, kerosene, acetone, MEK, paint thinner, harsh detergents or other chemicals. Use of these cleaners may result in permanent damage to the enclosure.
- After cleaning, apply two or more thin coats of either latex or oil-based paints. Latex paint will adhere best if an oil-based primer is used first. Application can be made by rolling, brushing or spraying.

Painting the Speaker Along With the Ceiling – Insert the clear plastic paint shield into the front of the speaker to mask the drivers and internal baffle, paint the speaker, then remove the shield.

Painting the Grille – Painting the grille requires removal of the logo prior to painting (the logo should be stuck back onto the grille after painting, making sure it is located in the exact center of the grille).

The backing to the grille is glued in place so that it can't interfere with the movement of the woofer cone. Leave the grille backing in place. Spray the grille lightly using thinned paint. Make sure the spray is light enough that when the grille is held up to the light, you can still see light through the grille holes (which means that sound can also get through). Spray only the front of the grille, not the back. Rolling or brushing the paint is discouraged because the mesh and/or backing may become clogged with paint and poor sound quality may result, however using a very short-napped roller can be made to work.

Safety Agency Compliance

S7232



LISTED

15CM

Signaling Speaker

The standard Control 12C/T, Control 14C/T and Control 16C/T models are certified per UL-2043 Fire Tests for Heat and Visible Smoke Release for Discrete Products and their Accessories Installed in Air Handling Spaces, NFPA-70 National Electric Code 1996, Article 300-22(C), and NFPA-90A Installation of Air Conditioning and Ventilation Systems, Section 2-3.10.1 (a), Exception 3. Listed UL1480-6 Speakers for Fire Protective Signaling Systems. SUITABLE FOR USE IN AIR HANDLING SPACES.

The C-VA models -- Control 12C-VA, Control 14C-VA and Control 16C-VA are certified per EN54-24



These products are in compliance with the EMC Directive 89/336/EEC and Article 10 (1) of the directive. In compliance with Technical Regulations EN50081-1 and EN50082-1. For a copy of the model-specific CE Declaration of Conformity, contact JBL at the address listed at the end of this manual.

Maintenance

No maintenance is required when installed in accordance with installation and wiring guidelines described in this manual.

Replacement Parts

There are no user serviceable parts inside these speakers. Refer servicing to an authorized JBL Service Center. For the name of an authorized Service Center in your area, contact JBL Professional at the address listed below.

Warranty & Contacting JBL

These products are designed and backed by JBL Professional, the world leader in sound reinforcement. For complete JBL warranty information, to order replacement parts or to ask for clarifications to this manual, contact JBL Professional:

WITHIN THE UNITED STATES: Contact the Applications Dept, JBL Professional, PO Box 2200, 8500 Balboa Blvd, Northridge CA 91329 USA. In the USA you may call Monday through Friday 8:00 am to 5:00 pm Pacific Coast Time (818) 894-8850.

IN OTHER AREAS THROUGHOUT THE WORLD:
Contact the JBL Professional Distributor in your country.

A list of JBL Professional Distributors and U.S. Service Centers can be attained from the JBL Professional WWW.JBLPRO.COM website.

Product Specifications

See product specification sheets for complete specification listings.

Control 12C-VA

Components: 76 mm (3 in) full-range driver
Frequency Range¹: 68 Hz - 17 kHz
Power Capacity (low-Z): 40 W Cont. Program
20 W Cont. Pink Noise
Sensitivity²: 84 dB
Coverage³: 130°
Max. SPL: 97 dB @ 1m ave., 103 dB peak
Nominal Impedance: 8 ohms (in direct/bypass 8Ω setting)
Transformer Taps: 15W, 7.5W, 3.8W @ 70V & 100V;
plus 1.9W @ 70V

Control 14C-VA

Components: 100 mm (4 in) LF driver
19 mm (3/4 in) HF driver
Frequency Range¹: 74 Hz - 20 kHz
Power Capacity (low-Z): 60 W Cont. Program
30 W Cont. Pink Noise
Sensitivity²: 87 dB
Coverage³: 120°
Max. SPL: 102 dB @ 1m ave., 108 dB peak
Nominal Impedance: 8 ohms (in direct/bypass 8Ω setting)
Transformer Taps: 25W, 12.5W, 6.3W @ 70V & 100V;
plus 3.2W @ 70V

Control 16C-VA

Components: 165 mm (6.5 in) LF driver;
19 mm (3/4 in) HF driver
Frequency Range¹: 62 Hz - 20 kHz
Power Capacity (low-Z): 100 W Cont. Program
50 W Cont. Pink Noise
Sensitivity²: 91 dB
Coverage³: 110°
Max. SPL: 108 dB @ 1m ave., 116 dB peak
Nominal Impedance: 8 ohms (in direct/bypass 8Ω setting)
Transformer Taps: 30W, 15W, 7.5W @ 70V & 100V;
plus 3.8W @ 70V

Contribution of Each One-Third Octave Frequency Band when Speaker is Driven at Full Volume, measured at 4 meter distance (req'd in this manual by EN54-24):

Control 12C-VA

Freq (Hz)	Value
500	57.4
630	57.2
800	57.4
1000	57.8
1250	57.4
1600	59.9
2000	58.9
2500	54.7
3150	57.3
4000	59.2

Control 14C-VA

Freq (Hz)	Value
500	58.8
630	58.0
800	58.4
1000	58.1
1250	57.7
1600	59.1
2000	59.0
2500	58.6
3150	60.8
4000	62.8

Control 16C-VA

Freq (Hz)	Value
500	62.5
630	62.3
800	63.7
1000	65.6
1250	62.2
1600	62.9
2000	63.8
2500	64.4
3150	63.7
4000	65.4

¹ Half-space (flush mounted in ceiling)

² Continuous Pink Noise Rating is IEC-shaped pink noise with a 6 dB crest factor for 100 hours continuously. Continuous Program Power is a conservative expression of the system's ability to handle normal speech and music program material, and is defined as 3 dB above the Continuous Pink Noise Rating.

³ Half-space (in ceiling) average 1 kHz to 16 kHz.



JBL Professional
8500 Balboa Blvd, P.O. Box 2200
Northridge, CA 91329 U.S.A.

5065359A