

# USER MANUAL - ELECTRONIC DIMMER PUSH-ROTARY MECHANISM FOR USE WITH 1-10V VOLTAGE CONTROLLED POWER SUPPLY UNIT

## Characteristics of the electronic dimmer push-rotary mechanism for use with 1-10V voltage controlled power supply unit

Electronic push-rotary dimmer designed to switch on and off and regulate the light intensity:

- LED lighting powered by dimmable LED power supplies controlled by 1-10V,
- 12V halogens powered by dimmable electronic transformers controlled by 1-10V,
- fluorescent lamps powered by dimmable electronic ballasts controlled by 1-10V.

A potentiometer with a switch is used to adjust the light level. The controller is equipped with short-circuit protection. The system enables intelligent control of lighting systems, providing comfort, convenience and economy in use. In this way, it increases daily savings in electricity, the consumption of which is proportional to the lighting level.

## Technical data

Symbol	MRO-3
Power supply	250V~ 50Hz
Min. control voltage	1 V DC
Max. control voltage	12 V DC
Max. control current	50 mA
Fuse	F-2A 250V
Number of connection clamps	4
Cross section of connection cables	max 1,5 mm <sup>2</sup>
Fixing of the casing	standard flush-mounted wall box fi 60mm
Temperature operation range	from -20°C to +45°C
Shield protection class	II (see: "Warning! Protection class of the shield")
Overvoltage category	II
Degree of contamination	2
Dimensions with outer frame	80,00 x 80,00 x 54,40 mm
Protection index	IP 20

## Warranty terms

The guarantee is provided for a term of twelve months from the date of purchase. The defective controller must be delivered to the producer or to the seller with a purchase document. The guarantee does not cover the fuse exchange, mechanical damage, damages raised by self-repair or improper use.

The warranty period shall be extended by the duration of the repair.

## Warning! Protection class of the shield

The installation must be carried out by a qualified person at de-energized voltage and must comply with national safety standards. In order to maintain Class II protection, the user must be prevented from accessing the rear parts of the installation.

# USER MANUAL

## Installation

1. Switch off the mains fuses of the home installation.
2. Dismantle the control key, then unscrew the nut, remove the washer and the dimmer adapter with the intermediate frame (see page 3 - components).
3. Connect the wires to the connection terminals according to the wiring diagram.
4. Install the dimmer module in the installation box using the box mounting screws or the metal claws included with the controller.
5. Install the controller components in the following order: external frame, intermediate frame, adapter and washer.
6. Screw in the nut, then mount the control key.
7. Switch on the mains fuses of the home installation and perform a test run.

## Electric connection scheme of the electronic lighting controller

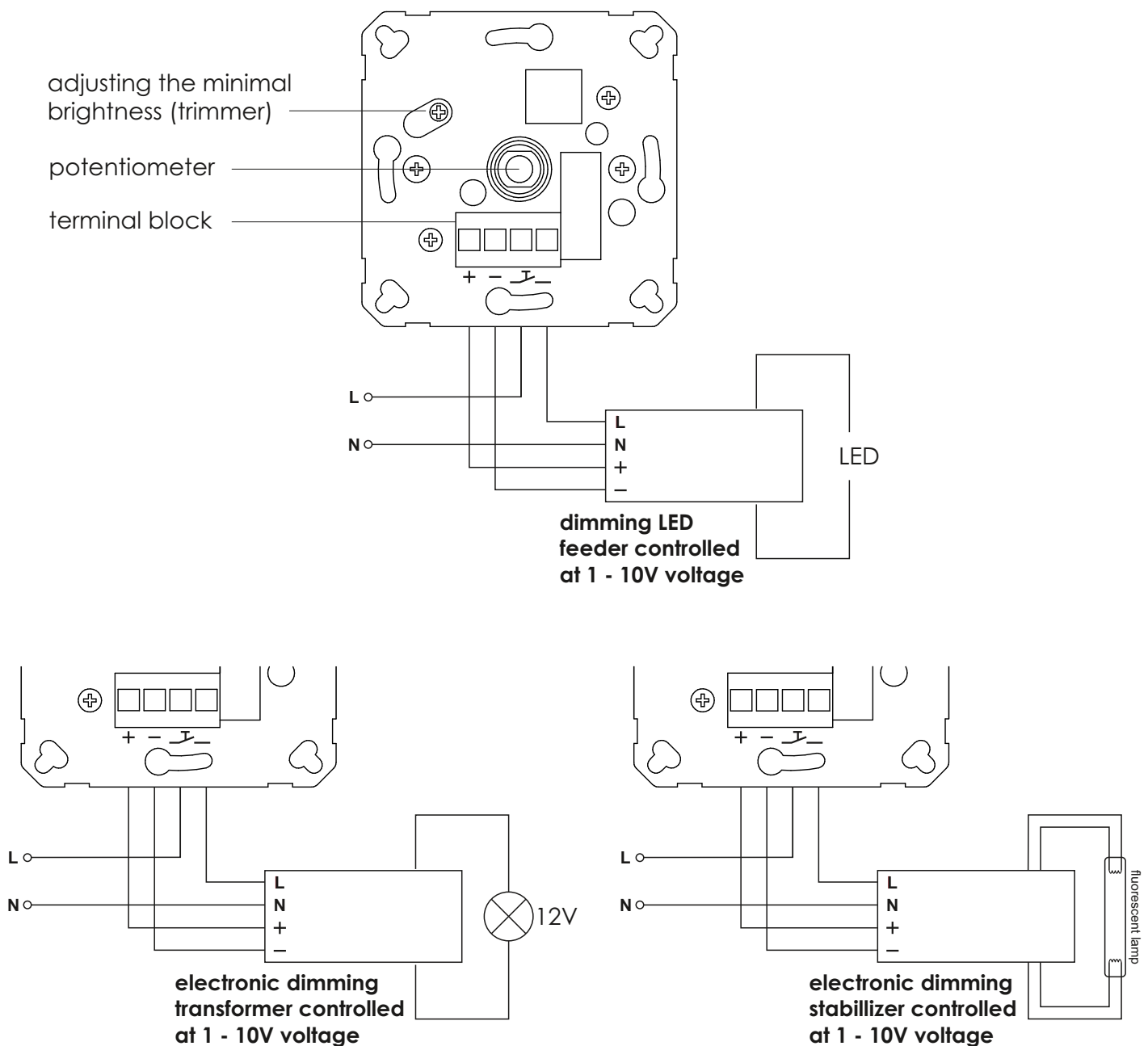

## Warning!

The product is compatible with DECO / MINI surface-mounted folding boxes. In order to properly install the lighting regulator in the box, unscrew the metal claws located at the mechanism.

## Components of the electronic lighting controller with push and rotary button for LED lamps

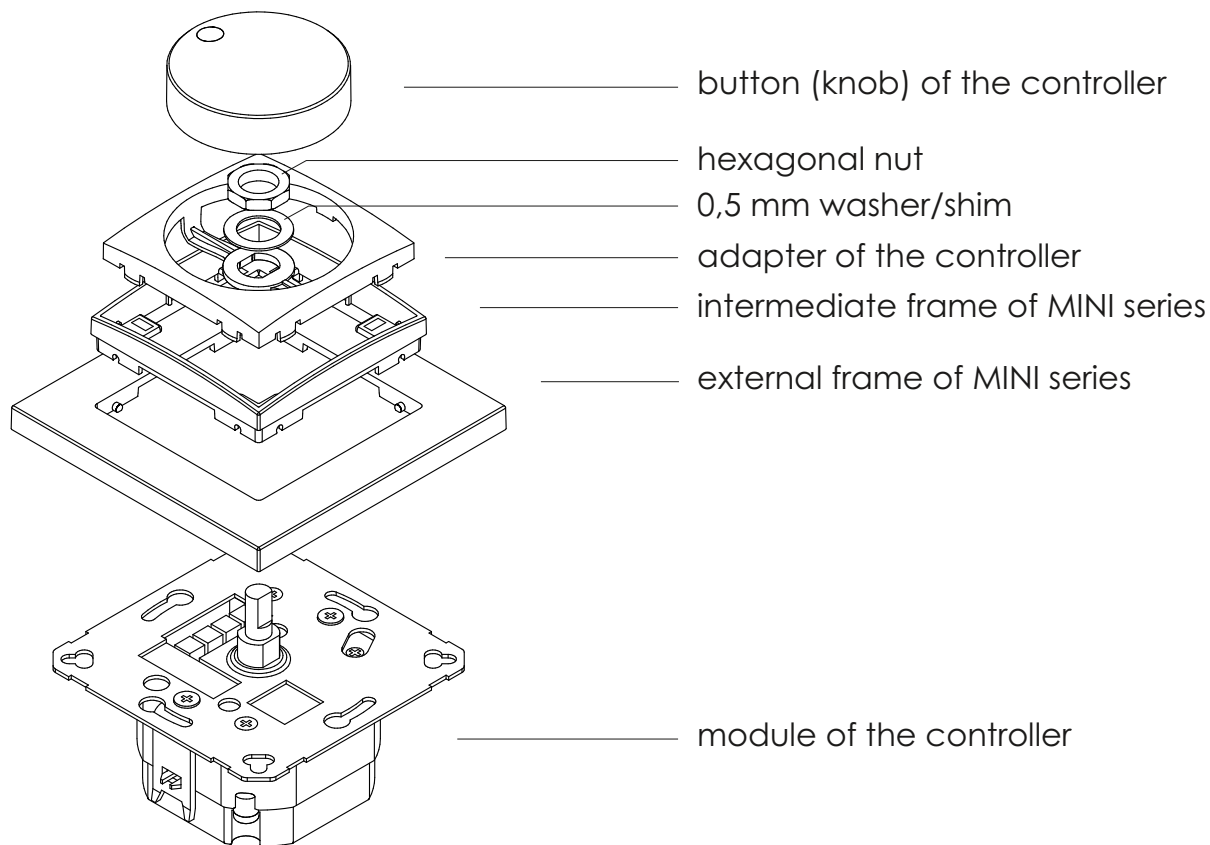

## Installation instructions for electronic light controller mechanism in multiple frames

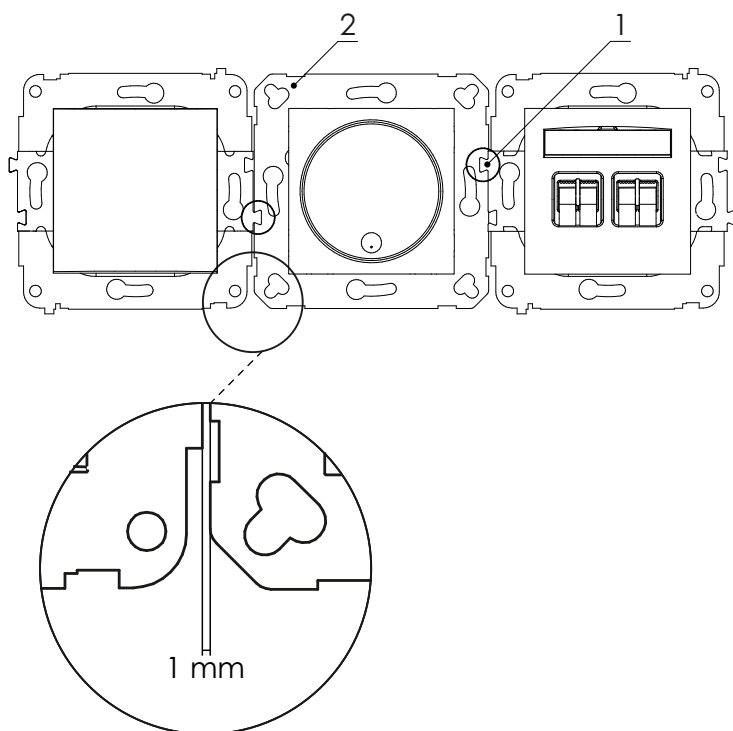

1. First, install the electronic light control mechanism in the mounting box. The other adjacent mechanisms are installed so that the "dovetails"(1) (if any) overlap the central plate of the controller (2).

2. The distance between the central frame of the dimmer and the adjacent products should be about 1 mm.