

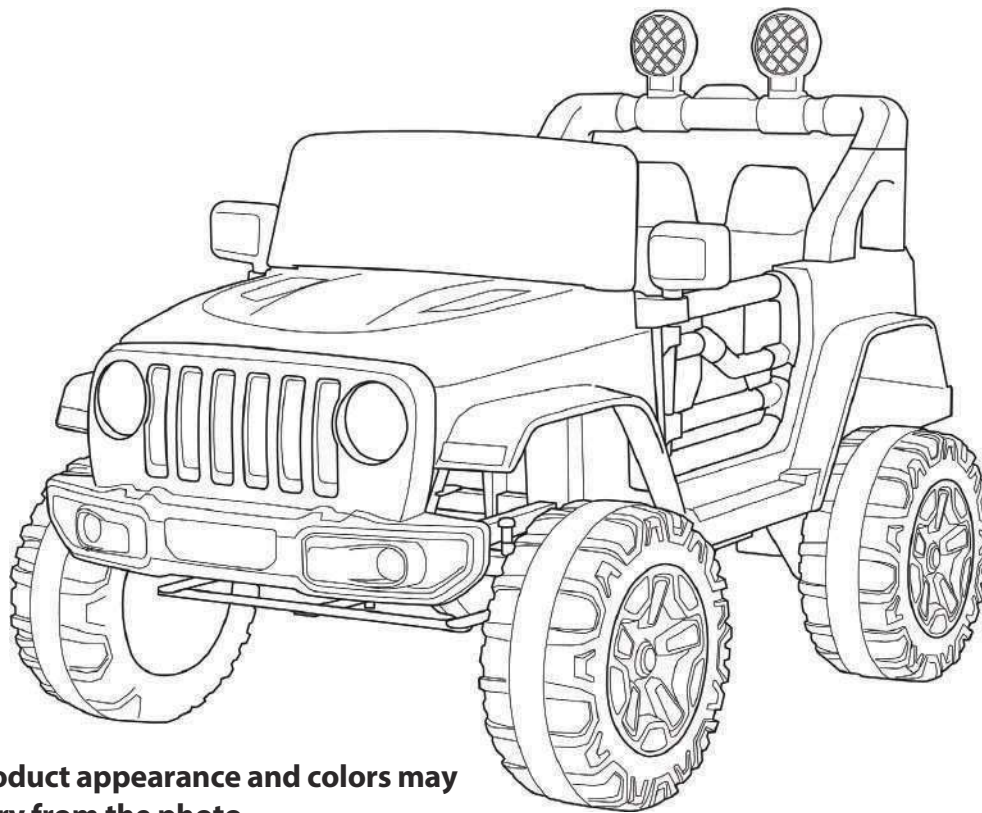

Instruction Manual

Ride on SUV w/ DIY License Plate (12V) (Fun Letters)

Item number: 060-ROT-10



* Product appearance and colors may vary from the photo.



WARNING :

This product should only be assembled by an adult.



ATTENTION



This vehicle is packed with the battery disconnected. Connect the battery before use.

This manual contains important safety, performance and maintenance information. Read the manual thoroughly before allowing your child to ride your new electric ride-on toy. Failure to read the user manual can result in property damage or bodily injuries. Keep this user manual for future reference.

Safety Instruction

When using electrical product, basic safety precaution should always be followed including the following:

Read all Instruction before operating this product

⚠️ WARNING:

- **To Protect against electrical shock, do not immerse cord, charger, transformer, battery, or the product in water or other liquid.**
- **Only use charging devices, transformer, and battery provided or recommended by the manufacturer.**
- **For your children's safety, the product should be assembled by adult.**
- **Close and constant adult supervision is required when your child is operating this product.**
- **Disconnect the battery if not used for a long time.**
- **Do not use this product as a traffic tool.**
- **To reduce the risk of injury, adult supervision is required. Never use in roadways, near motor vehicles, on or near steep inclines or steps, swimming pools or other bodies of water; always wear shoes, and never allow more than 1 rider.**
- **RISK OF FIRE. Do not bypass fuse. Replace only with original size and type.**
- **Do not use this product on slippery surface. Always drive the vehicle on smooth surface, and do not drive the vehicle on the tall grass or rugged ground.**
- **Rider should always wear shoes when riding on this product.**
- **Always keep hands, hair, clothing, and loose items away from moving parts.**
- **Maximum users' weight for this product is 66 lb / 30 kg.**
- **This product is suitable for children age 37 - 95 months old.**
- **Do not change, modify or add any electrical wiring on this product.**
- **Avoid using this product in tight environment to prevent damage to the product or injury to the user.**
- **Do not use this product in the dark. Only operate this product during daytime or well-lit area.**
- **For your child's safety, please make sure the seatbelt is securely fastened when operating this product.**
- **Personal protective equipment such as helmet is needed when using this product.**



⚠ WARNING:

PREVENT FIRE

- **Never modify the electrical system. Alterations could cause a fire resulting in serious injury and could also ruin the electrical system.**
- **Use of the wrong type of battery or charger could cause a fire or explosion resulting in serious injury.**
- **The battery must be handled by adults only. The battery is heavy and contains sulfuric acid(electrolyte). Dropping the battery could result in serious injury.**
- **Never allow children to charge the battery. Battery charging must be done by adults only.**
- **Never lift or carry the battery by the wires or connector. This can damage the battery and possibly cause a fire resulting in serious injury. Lift and carry the battery by the case only.**
- **Examine the battery, charger and their connectors for excessive wear or damage each time you charge the battery. If damage or excessive wear is detected, do not use the charger or the battery until you have replaced the worn or damaged part.**

⚠ WARNING:

Avoid continuously hitting into obstacle to prevent overheating or damaging the motor. Drive away or remove obstacle as soon as possible.

⚠ WARNING:

Manufacturer and seller expressly disclaim any and all liability for personal injury, property damage or loss, whether direct, indirect, or incidental, resulting from the incorrect attachment, improper use, inadequate maintenance, unapproved modification, or neglect of this product.

⚠ WARNING: CHOKING HAZARD - Small parts. Not for children under 3 years.

⚠ WARNING: This toy is to be assembled by an adult. Contains potentially hazardous sharp edges and sharp points, or contains small parts before assembly.

⚠ WARNING: Do not drive this vehicle into any puddle or contact with any liquids to avoid the electrical shock to product or user.

WARNING

FAILURE TO FOLLOW THE SAFETY INSTRUCTIONS LISTED BELOW MAY RESULT IN SERIOUS INJURY OR DEATH.

The owner's manual contains assembly, use and maintenance instructions.

Child Safety Warnings

- **Adults supervising children must read and understand this entire manual before allowing any child to use this product.**
- **Adults must evaluate their own children as to maturity, strength, judgment and ability to follow safety rules. Published age guidelines are not a substitute for careful evaluation of your own child.**
- **Adults must teach children about thinking ahead while riding as this may be the first time a child has ever controlled a motorized ride-on toy. While you supervise, see through the child's eyes, and verbally teach them about steering and avoiding obstacles in the approved riding area.**
- **Riding a motorized ride-on toy can be a dangerous activity, even under the best of circumstances. Good choices regarding where and when to ride, constant adult supervision of riding, and practice and careful riding by the child can all help to minimize risk. However this ride-on toy is intended to move and therefore it is possible for the rider to lose control, fall off and/or get into dangerous situations that no amount of care, instruction or expertise can eliminate.**
- **If this inherent risk is not acceptable, adults should not allow children to ride this ride-on toy.**

WARNING

Safe Riding Warnings

- **Not to be used by children under 36 months or children over 96 months..**
- **Do not exceed the maximum weight capacity of 66 lb (30 kg).**
- **Do not allow more than one (1) rider.**

ADULTS AND SUPERVISORS, PLEASE NOTE:

- 1• **Always instruct all children of common sense rules and safe practices.**
- 2• **Be aware that flat, hard surfaces provide the safest experience for child riders.**
- 3• **Do not allow the child rider to operate the ride-on toy near streets, roads, sidewalks, walkways, or any other place where they may encounter other moving vehicles.**
- 4• **Never leave children unattended with this ride-on toy. Continuous adult supervision is required.**

WARNING

- 5• If necessary, adults and supervisors are always responsible for setting up gates and barriers to ensure a safe riding environment for the child rider.**
- 6• Be aware that this ride-on toy does not have braking capabilities. Allowing use of this ride-on toy in areas that require braking may cause rolls, crashes, serious injury, or death to the child rider.**
- 7• Teach children not to allow other children to use this ride-on toy. Communicate this message to other adults and supervisors of fellow children with which your child interacts.**
- 8• Sternly alert children that hands, legs, hair, and clothing can potentially get caught in moving parts. Ensure they never place a body part or piece of clothing near a moving part of the ride-on toy. Avoid loose clothing.**
- 9• Instruct children to always wear shoes when using the ride-on toy.**
- 10• Confirm that children do not have access to the charging equipment or come into contact with any part of the ride-on toy while it is charging.**
- 11• Firmly instruct children to use the ride-on toy in a safe manner. Unsafe behaviors include, but are not limited to:**
 - Traveling at unsafe speeds**
 - Not riding in the seated position**
 - Riding at night or in any conditions of low visibility**
 - Riding in any wet conditions including rain, snow, and ice**
 - Any kind of stunt riding: jumps, ramps, stairs, hills, sloped surfaces, or other actions involving any notable risk**
 - Any kind of off-road riding: rough terrain, dirt, mud, gravel, or any others that involve notable risk**
 - Riding near any pool or open body of water**
 - Pushing, pulling, or shoving the driver in any way while operating the ride-on toy**
 - Using the ride-on toy without the battery cover or any other safety cover fully closed**
 - Pulling or hitching the ride-on toy with other similar moving ride-on toys or products**

WARNING

Battery and Charging Warnings

The following safety hazards may result in serious injury or death to the user of the ride-on:

- Do not mix old and new batteries.
- Do not mix alkaline, standard (carbon-zinc), or rechargeable batteries.



Corrosive Material Warnings

- Battery posts, terminals and related accessories contain lead and lead compounds (acids) chemicals and are toxic and corrosive. Never open the battery.
- Contact or exposure to battery leakage (lead acid) may cause serious injury. If contact or exposure occurs with the skin or in the eyes, or if the chemical is swallowed, immediately call 911.



Flammable and Explosive Materials Warnings

- Use of a battery or charger other than the supplied rechargeable battery and charger may cause a fire or explosion. Only use the supplied rechargeable battery and charger with the ride-on toy.
- Do not charge the battery near heat or flammable materials.
- Using the rechargeable battery and charger for any other product may result in overheating, fire or explosion. Never use the rechargeable battery and charger with another product.
- Contact between the positive and negative terminals may result in fire or explosion. Avoid direct contact between the terminals. Lifting the battery by the wires or charger can cause damage to the battery and may result in a fire. Always lift the battery by its case or handles.
- Plug wall charger directly into a wall outlet. Do not use an extension cord when charging as the use of an extension cord can cause a fire.



Electric Shock / Fire Warnings

- Liquids on the battery may cause fire or electric shock. Always keep all liquids away from the battery and keep the battery dry.
- Tampering or modifying the electric circuit system may cause a shock, fire or explosion and permanently damage the system. Exposed wiring, circuitry in the charger may cause electric shock. Always keep the charger housing closed.

WARNING

- **Regularly check charger, supply cord and connector for wear and damage. Look for frayed or kinked wires, any exposed inner wires, any missing insulation. If any damage is observed do not plug in the charger and do not charge the battery.**

CAUTION

Re-Charge Interval and Time Important!

- **Damage to the battery may occur if it is allowed to drain completely. Do not allow the battery to drain completely.**
- **Check the battery and charger (supply cord, connector) for wear and damage before charging. Do not charge the battery if damage has occurred. Do not use an extension cord when charging the ride-on toy.**
- **On average you will need to charge the battery for 8-12 hours and no more than 20 hours. Failure to charge the battery as directed could cause permanent damage to the battery and void the warranty.**
- **Only an adult who has read and understands the safety warnings should handle, charge and recharge the battery.**

WARNING

Assembly Warnings

- **The ride-on toy must be assembled by an adult who has read and understands the instructions in this manual.**
- **Choking hazard to children under the age of 3 years.**
- **This ride-on toy contains small parts that are for adult assembly only. Keep small children away when assembling.**
- **Remove and dispose of all protective materials, plastic bags and packaging before assembly.**

Product Specification

Model No.: 060-ROT-10

Battery: 12V 4.5AH x 1

Charger input: 100 - 240V AC

Charger output: 12V 500mA

Speed: 1.3 - 2 mph (2.1 - 3.25 km/h)

Suitable Age: 37 - 95 months

Maximum User Weight: 66 lb / 30 kg

Dimension: 39.4" x 25.6" x 28.4" (100 x 65 x 72 cm)

Battery Charge Time: 8 - 12 hours

Operation Time: About 40 Minutes

Parts and Feature



A. Car Body
1x



B. Windshield
1x



C. Steering Wheel
1x



D. Wheel
4x



E. Small Wheel Cover
4x



F. Rear Spring Holder
2x



G. Rearview Mirror Holder
2x



H. Rearview Mirror
2x



I. Door
2x



J. Motor
2x



K. Search Light Holder
2x



L. Search Light
1x



M. Front Spring
2x



N. Rear Axle
1x

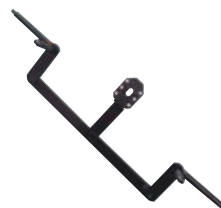

O. Front Axle
1x

Parts and Feature



P. Seat
1x



Q. Spanner
2x



R. M4 x 14 Screw
21x



S. Nut
7x
(2pcs pre-installed
on the front axle)



T. Remote Control
1x



U. Charger
1x



V. Flat Iron
1x



W. Big Washer
2x
(For front axle inner side)



X. Small Washer
7x
(2pcs pre-installed on the front axle)



Y. MP3 Cable
1x



Z. Rear bracket
1x

Tool Required:

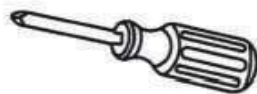

Screwdriver
(Not included)



Q. Spanner
2x

Assembly Instruction

(The following diagrams for reference only, the photos may vary from actual product.)



Attach the Flat Iron as arrow. then turn the whole front axle assembly upside down

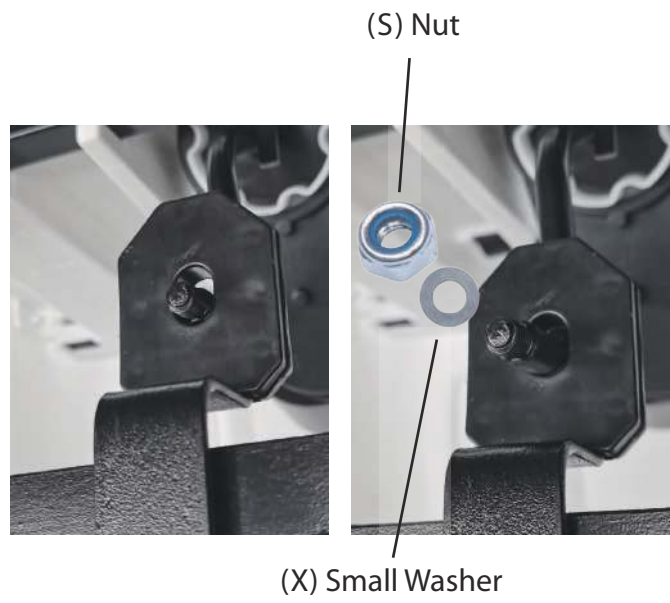
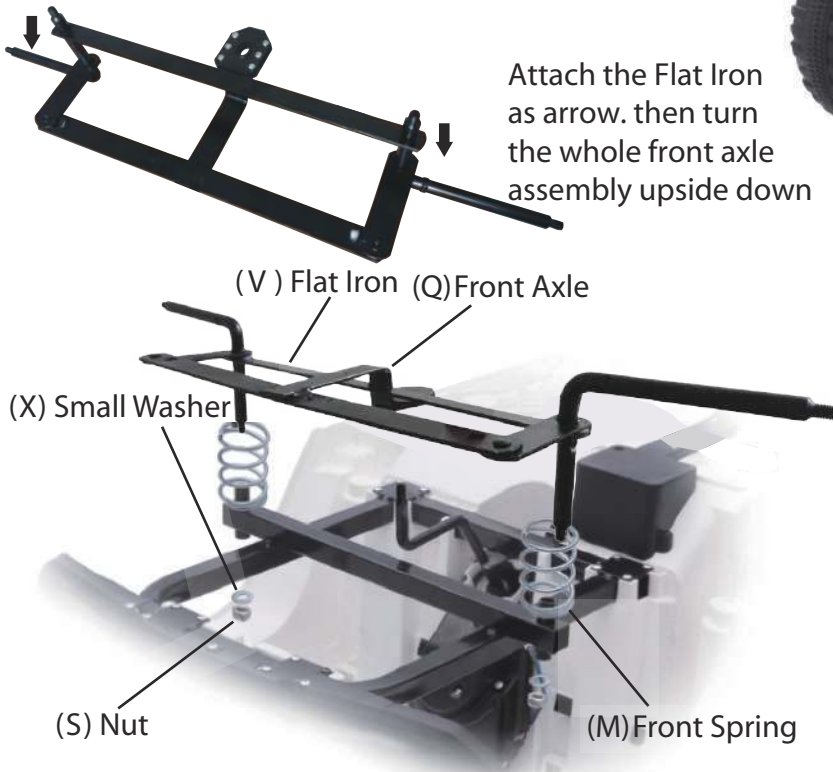

- Assemble the Flat Iron (V) to the Front Axle(Q), then turn the front axle assembly upside down.
- Insert Front Spring (M) on the square tube, then insert the Front Axle (Q) assembly to the hole on the side of the square tube.
- Assemble the tie rod of the Front Axle to the Steering rod and tighten with Small Washer (X) and Nut (S).
- Then secure the front axle assembly on the square tube with Small Washer(X) and Nut(S) (the small washers and nuts were pre-installed on the front axle).

Assembly Instruction

Front wheel assembly:

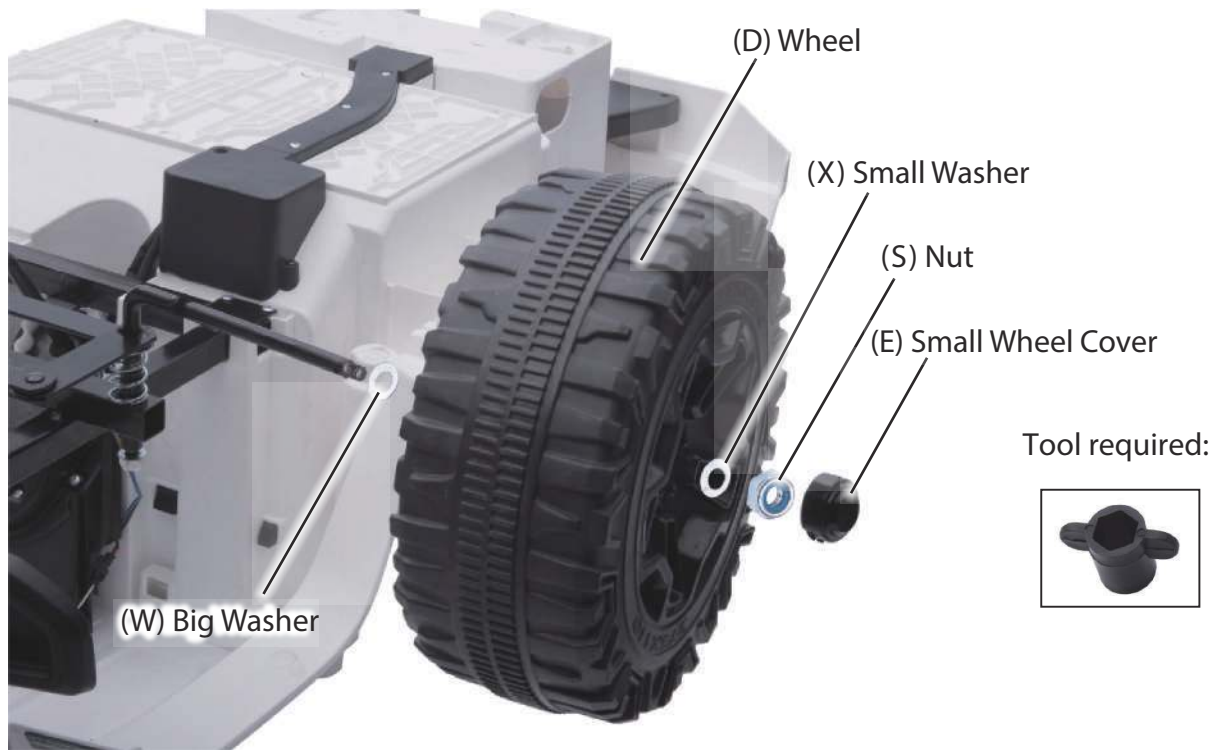

- Insert a Big Washer (W) to a side of the Front Axle, follow by the Wheel (D), then secure a Small washer (X) and Nut (S) by the spanner. Cover the nut with a Small Wheel Cover (E).
- Repeat the same step on the other side.

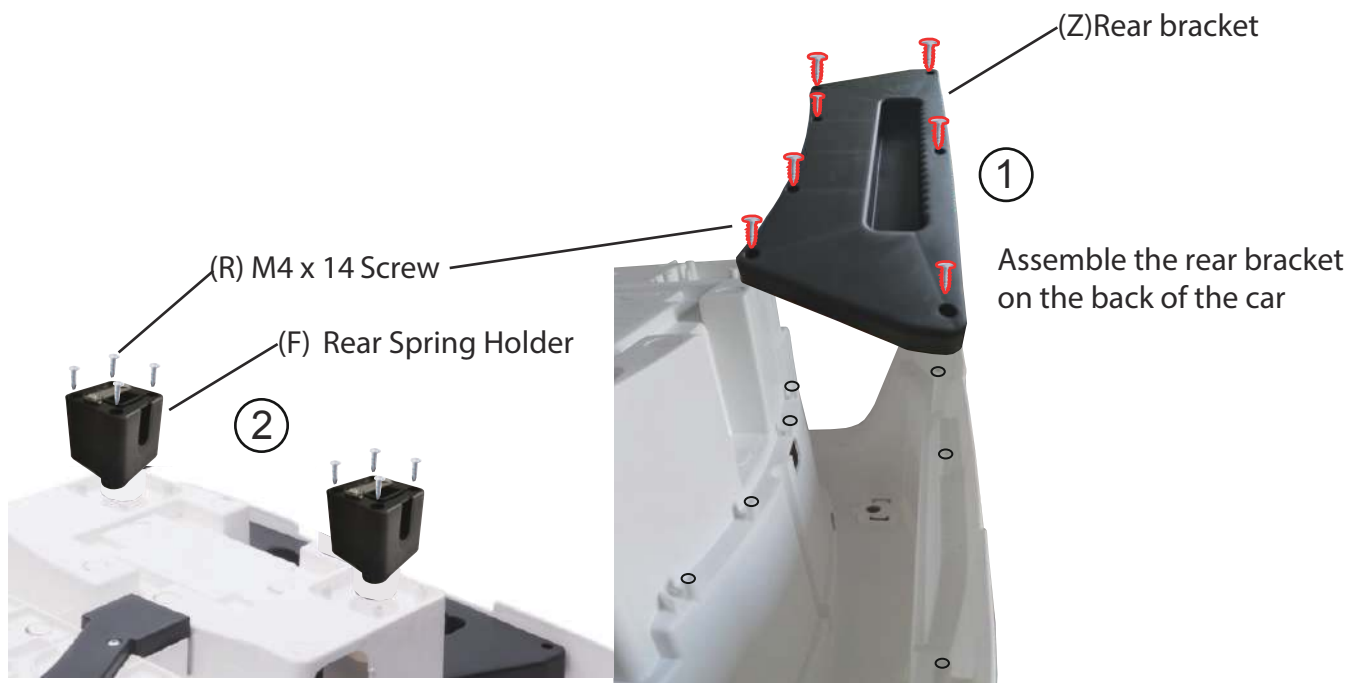

- Insert 2 Rear Spring Holders (F) to the car body, and secure using M4 x 14 screws (R).

Assembly Instruction

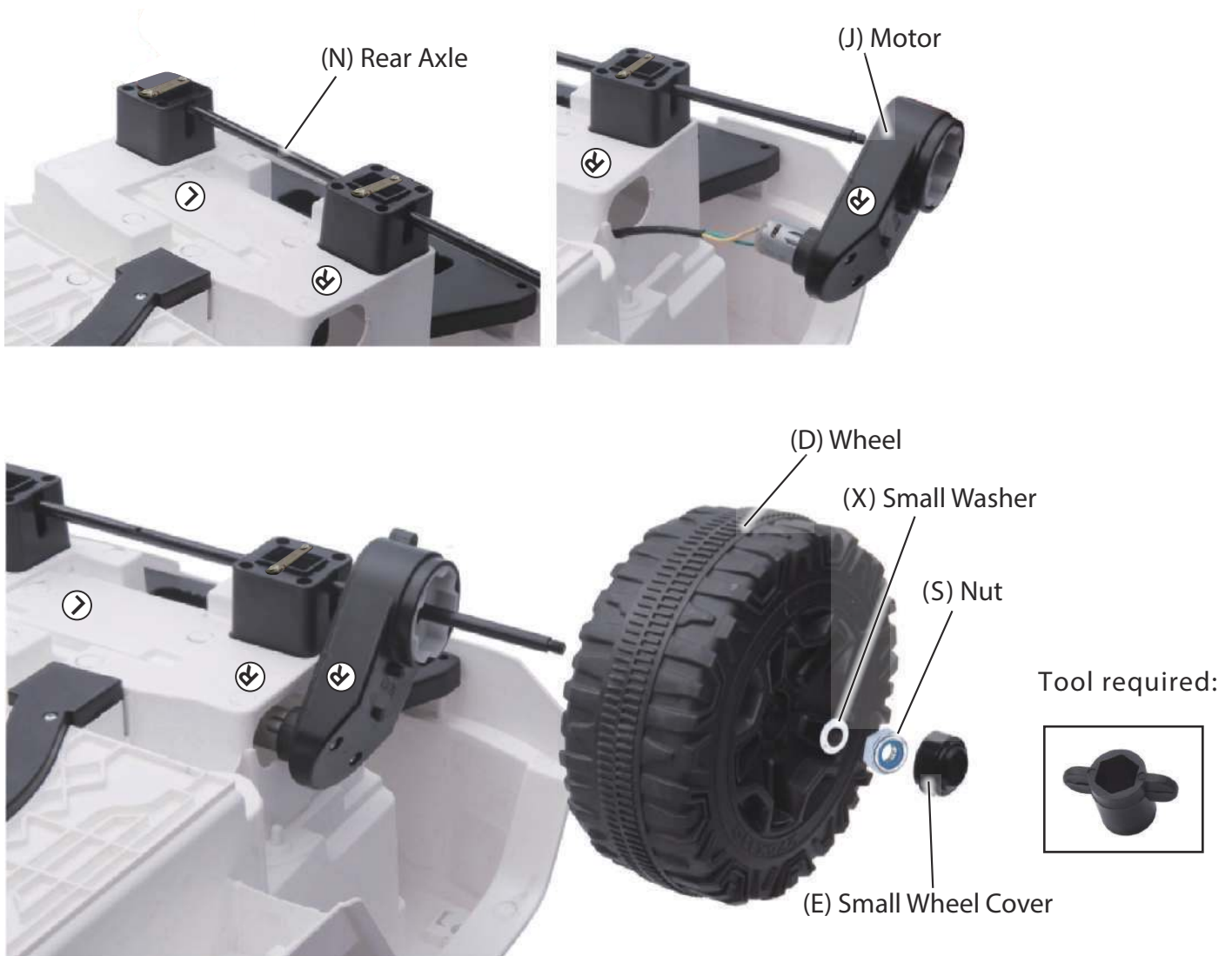

- Insert Rear Axle (N) through the opening hole of the Rear Spring Holders.
- Insert Motors (J) to each end of the rear axle. (the motor mark with "L" or "R", pls. match to corresponding marking (L/R) on the chassis as above diagram for assemble)
- Assemble Wheel (D) to the rear axle and secure with a Small Washer (X) and Nut (S). Then cover with Small Wheel Cover (E).
- Repeat the same step for the another wheel.

Assembly Instruction

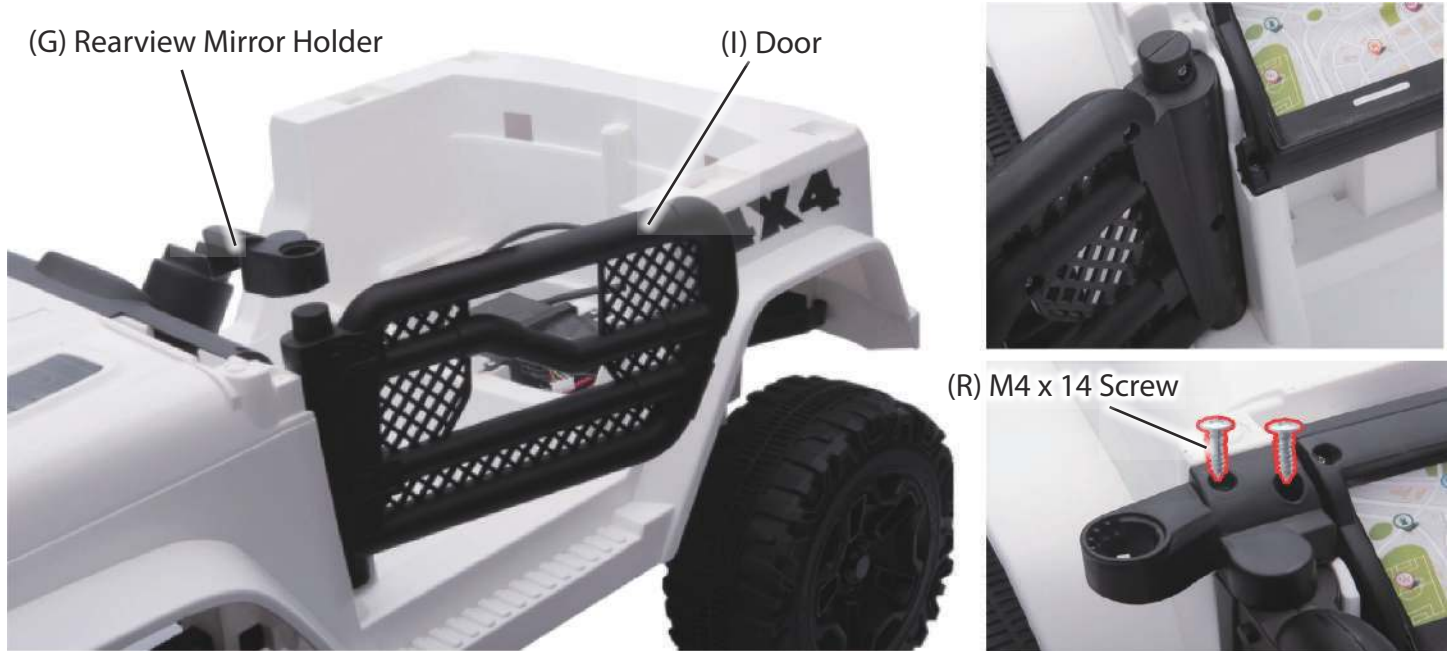

- Insert the Door (I) into the side of the car body.
- Assemble a Rearview Mirror Holder (G) on the door and car body using M4 x 14 Screws (R).
- Repeat the same step on the other side.



- (1) Unscrew the screw and nut from the Steering Wheel (C).
- (2) Insert the steering wheel to the steering column and secure with the screw and nut.

Assembly Instruction



- Insert Windshield (B), Rearview Mirrors (H), Search Light Holder (K), and Search Light (L) to the car body in their corresponding position.
- The search light holder marked with L / R , please ensure them assemble in corresponding position (L to Left side, R to Right side).

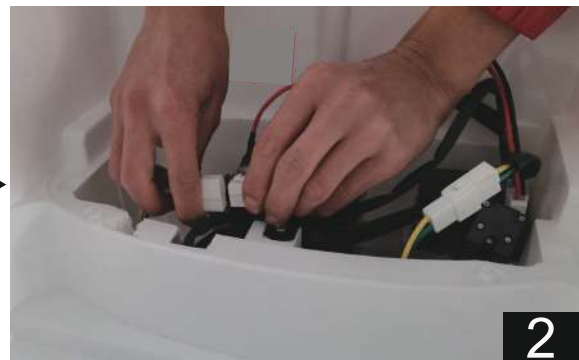

- Connect the motor lead to the white terminal. (step 1 & 2 , white to white)
- Connect the red battery connector to the red terminal. (step 3, red to red)

Assembly Instruction



- Align and assemble the Seat (P) to the car body and secure using 2 M4 x 14 screws (R).

User Instruction (Control Panel)

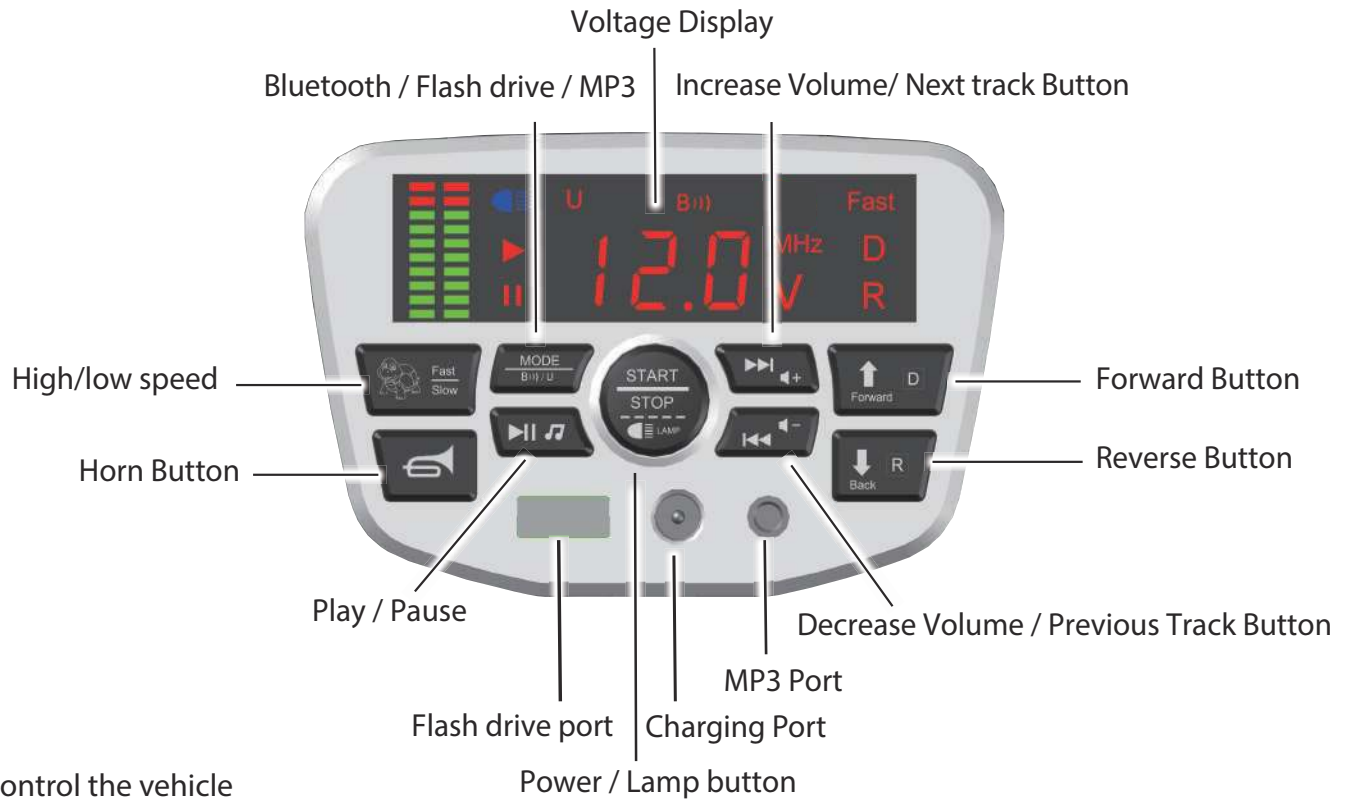

Control the vehicle

A. Power / Lamp Button

Press and hold the button 2-3 seconds to turn ON or OFF the vehicle; Quick press the button once to enable the light on or off.

B.High /Low Speed Button

Press the button to move the vehicle in high or low speed.

C.Horn Button

Press the horn button to make a beeping sound.

D.Play / Pause Button

Press the button to play or pause the music.

E. Charging Port

Connect the charger to the charging port to recharge the battery.

F. Decrease Volume / Previous Track Button

Press and hold the button to decrease volume; Press once to play the previous track.

G.Forward / Reverse Button

Press the switch to control the vehicle to move forward / reverse.

Do not switch between forward and reverse until the vehicle comes to a complete stop.

H. Increase Volume / Next track Button

Press and hold the button to increase volume; Press once to play the next track.

I.Voltage Display

Display the voltage of the battery.

J. Mode Button

Press to switch between bluetooth / flash drive / MP3.

K. Flash drive port

Connect to flash drive.

L. MP3 Port

Connect to MP3.

User Instruction (Remote Control)

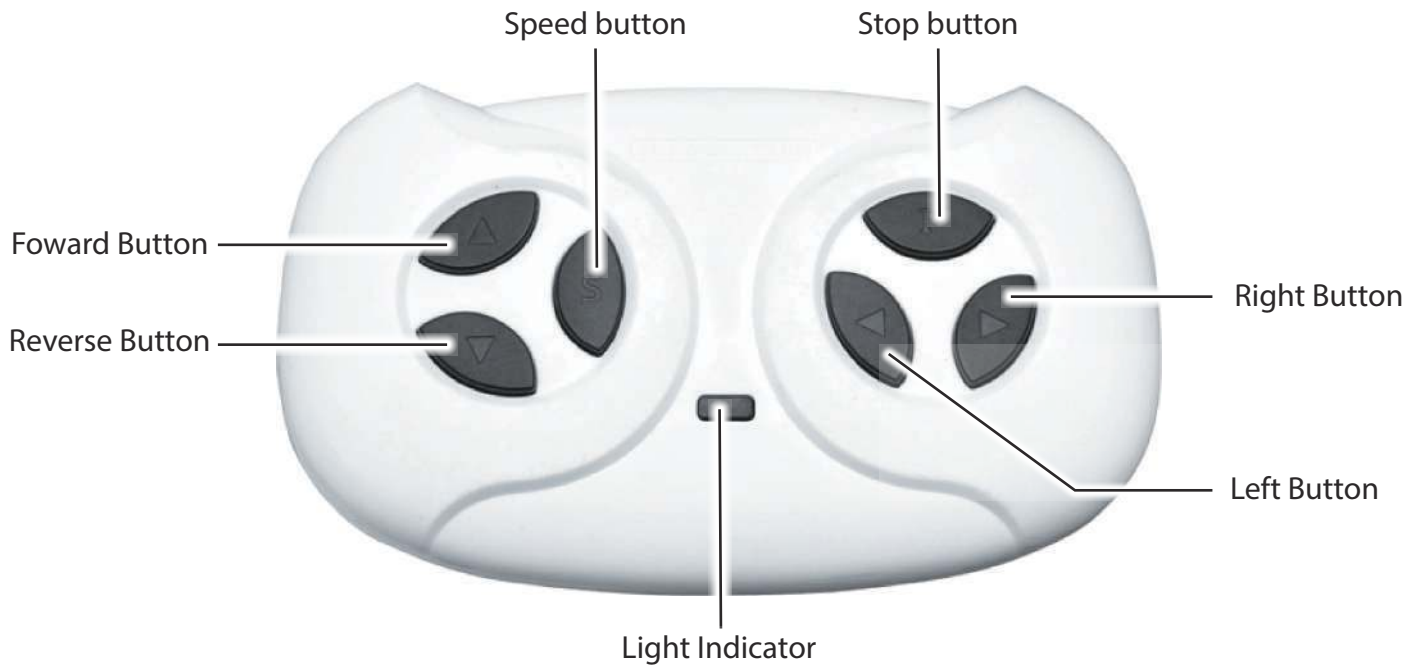

Remote Control Buttons

1. Forward Button

Press to move the vehicle forward.

⚠ Do not switch between forward and reverse until the vehicle comes to a complete stop.

2. Reverse Button

Press to move the vehicle backward.

⚠ Do not switch between forward and reverse until the vehicle comes to a complete stop.

3. Speed Selection Button

Press to switch between low, middle and high speed.

The light indicator will indicate the speed as this: one light=low speed, two lights = middle speed, three lights= high speed.

4. Stop Button

Press to stop the vehicle.

5. Right Button

Press to turn the vehicle to the right.

6. Left Button

Press to turn the vehicle to the Left.

7. Light Indicator

Light indicator will indicate the pairing status between the car and the remote control. It also indicate the speed as this: one light=low speed, two lights = middle speed, three lights= high speed.

User Instruction (Remote Control)

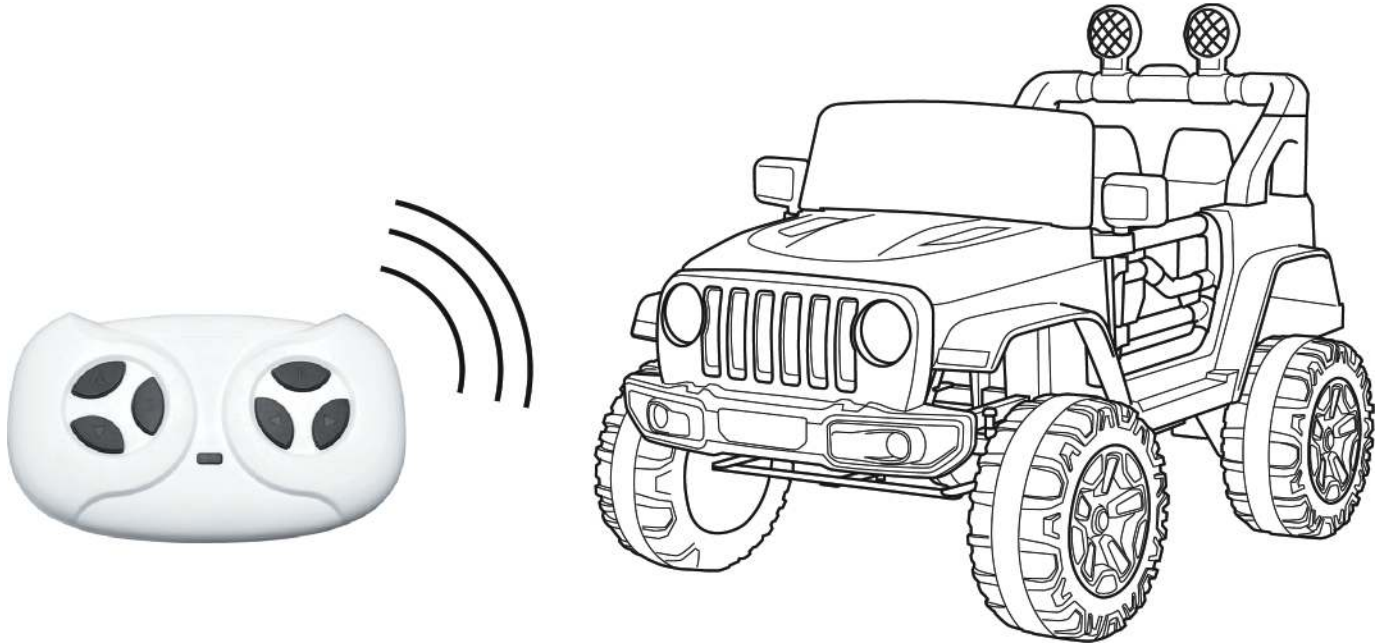

Using the remote control

The remote control should only be used by adult or under adult supervision.

⚠ ATTENTION:

The remote control will override all control input from the vehicle.

Insert / Changing Battery

1. Open the battery cover on the back of the remote control.
2. Insert 2 x AAA 1.5V batteries in the correct polarity.
3. Put the cover back to the remote control.

⚠ WARNING:

Do not mix old and new batteries. Do not mix alkaline, standard (carbon-zinc), or rechargeable batteries.

⚠ WARNING:

The battery should only be changed by an adult.

Pairing the remote control to the vehicle

1. Press Forward and Reverse button simultaneously until the indicator light flashes.
2. Then turn on the vehicle power.
3. The indicator light should stay on after successful pairing.

User Instruction (Charging)

WARNING:

The battery should only be charged by an adult.

Charging the battery

1. Locate the charging port on the control panel.
2. Connect the charger to the charging port.
3. Plug the charger into a wall outlet. The battery will start charging.
4. The indicator on the charger will red during charging, and turn to green after charging completed.
5. Battery Charge Time: 8 - 12 hours. Do not charge the battery for more than 20 hours.



- The vehicle must be OFF when charging.
- Recharge the battery if the vehicle operates slowly.
- The vehicle has equipped with charging protection. All function of the vehicle will not be operational when charging.

NOTE:

Damage to the battery may occur if it is completely drained.

Charge the battery at least once a month even if not operating the vehicle to maximize the battery life.

Care and Maintenance

- Check the product regularly and make sure there is no missing or loose parts. Re-tighten any loose parts if necessary.
- Make sure there is no cracked or broken plastic parts.
- Keep away the product from heat and humid area, cover it with trap when not in use.
- Turn off the product and disconnect the battery if the product is not use for a long period of time.
- Clean the vehicle with a cloth. Use a non-wax furniture polish to restore the shininess of the plastic parts. Do not use abrasive cleaner.
- Do not wash the product with a hose or immerse any parts in water or other liquid.
- Occasionally use lightweight oil to lubricate moving parts.

Troubleshooting

Problem	Possible Reason	Solution
Vehicle does not move	Low Battery	Fully charge the battery
	Fuse Protection	Motor current cuts off if overloaded or operated incorrectly. Wait for 7 - 10 seconds to reactivate the vehicle automatically.
	Disconnected / Badly connected battery	
		Reconnect the battery
	Failed battery / engine	Contact Customer Service
Vehicle does not run very long	Low Battery	Fully charge the battery
	Old Battery	Replace battery if necessary
Vehicle runs very slow	Low Battery	Fully charge the battery
	Old Battery	Replace battery if necessary
	Vehicle is overloaded	Make sure user's weight is under 66 lb / 30 kg
	Vehicle is being used in harsh environment	Avoid using the vehicle in harsh environment

Troubleshooting

Problem	Possible Reason	Solution
Vehicle needs a push to go forward	Poor wire connection	Check if the battery connectors are firmly connected. Contact Customer service if necessary
	"Dead spot" on motor	Contact customer service
Loud grinding sound or clicking sound from the motor or gear box	Damaged motor or gear box	Contact customer service
Battery does not charge	Disconnected / Badly connected battery	Reconnect the battery
	Disconnected / Badly connected charger	Make sure the charger is firmly plugged into the power source and connected to the charging port
	Charger not working	Contact customer service
Vehicle does not stop	Damaged equipment	Contact customer service
Charger becomes warm during charging	Normal	N/A



Controller:
Model: JR1602FCC
FCC ID: 2AWOBJR1602
Vehicle:
Model: 060-ROT-10
FCC ID: 2AX5C-JC111B

This device complies with part 15 of the FCC rules. Operation is subject to the following two conditions:
(1) This device may not cause harmful interference, and
(2) this device must accept any interference received, including interference that may cause undesired operation.

NOTE: This equipment has been tested and found to comply with the limits for a Class B digital device, pursuant to Part 15 of the FCC Rules. These limits are designed to provide reasonable protection against harmful interference in a residential installation. This equipment generates, uses and can radiate radio frequency energy and, if not installed and used in accordance with the instructions, may cause harmful interference to radio communications. However, there is no guarantee that interference will not occur in a particular installation. If this equipment does cause harmful interference to radio or television reception, which can be determined by turning the equipment off and on, the user is encouraged to try to correct the interference by one or more of the following measures:

- Reorient or relocate the receiving antenna.
- Increase the separation between the equipment and receiver.
- Connect the equipment into an outlet on a circuit different from that to which the receiver is connected.
- Consult the dealer or an experienced radio/TV technician for help.

Caution: Changes or modifications not expressly approved by the party responsible for compliance could void the user's authority to operate the equipment.

This Product conforms to toy safety standards CPSIA and ASTM-F963.

Importer: Align Inc.

Importer Address: 19301 E Walnut Dr. N., City of Industry, CA 91748 United States

Importer Tel: 1-800-946-6151

Limited Term Warranty(One Year from Date of Purchase)

WARRANTY TERMS

KIDZONE warrants that its merchandise are free from manufacturing defects (workmanship and/or material) and will either give credit or replace defective parts for a period of up to one (1) year from the date of purchase in accordance with the conditions set forth below. If a manufacturing defect is found, KIDZONE should be notified promptly of the defect and supplied a copy of the invoice and delivery ticket. Inspection by a KIDZONE employee or representative may be necessary to verify that a manufacturing defect exists, or you may be required to submit samples to KIDZONE along with a digital image of the defects. If replacement is required in accordance with this warranty and the defective material or merchandise has been discontinued or unavailable, KIDZONE reserves the right to select and supply similar merchandise or offer full credit for the merchandise; otherwise the same material or merchandise will be supplied for replacement purposes. This warranty is made solely to the retailer and is not transferable under any circumstances. It is the retailer's responsibility to contact KIDZONE with a claim. We will not handle claims from consumers directly; all requests must go through the retailer who sold the merchandise to the consumer. We advise all retailers to retain invoices for a minimum of one (1) year for warranty purposes. This warranty supersedes and replaces all implied warranties of merchantability and use for particular purpose. No representative, employee, agent or any other person is authorized to assume for KIDZONE any additional liability or responsibility in connection with KIDZONE's merchandise except as described above. Implied warranties or merchantability and fitness of the merchandise are limited to a period of one (1) year from the date of purchase. In no event shall KIDZONE be liable for indirect, consequential or incidental damages of any kind.

ADDITIONAL CONDITIONS

THE FOLLOWING EXAMPLES ARE NOT MANUFACTURER'S DEFECTS:

- Colors may vary slightly from the photo because of photography and printing tolerances.
- Sizes stated in U.S. standard measurements may vary slightly due to product are manufactured using the metric system.
- No returns for buyer's remorse.
- No returns - other than stated above will be accepted.

ADDITIONAL CONDITIONS

WARRANT IS VOID FOR ANY OF THE FOLLOWING CONDITIONS:

1. Improper maintenance or improper use resulting in damage.
2. Any product modifications by dealer, consumer, or other parties not authorized by KIDZONE will void this warranty.
3. Floor samples sold or products designated "AS IS" at the time of purchase are not covered by the warranty
4. Warranty does not cover minor variations or differences between floor samples or printed illustrations and your product.
5. Cost of packaging and shipping to and from KIDZONE is not covered by the warranty unless expressly arranged by KIDZONE.
6. This warranty covers only articles of appliances intended for residential use only, does not cover any industrial, commercial, institutional or Rental use.
7. Dissatisfaction due to buyer's remorse.
8. Normal wear and tear.
9. Damages incurred during transportation.
10. Damages incurred during assembling or maintenance.
11. Damage incurred by accidents or abuse.

V5-2023-7-7