

Kidzone

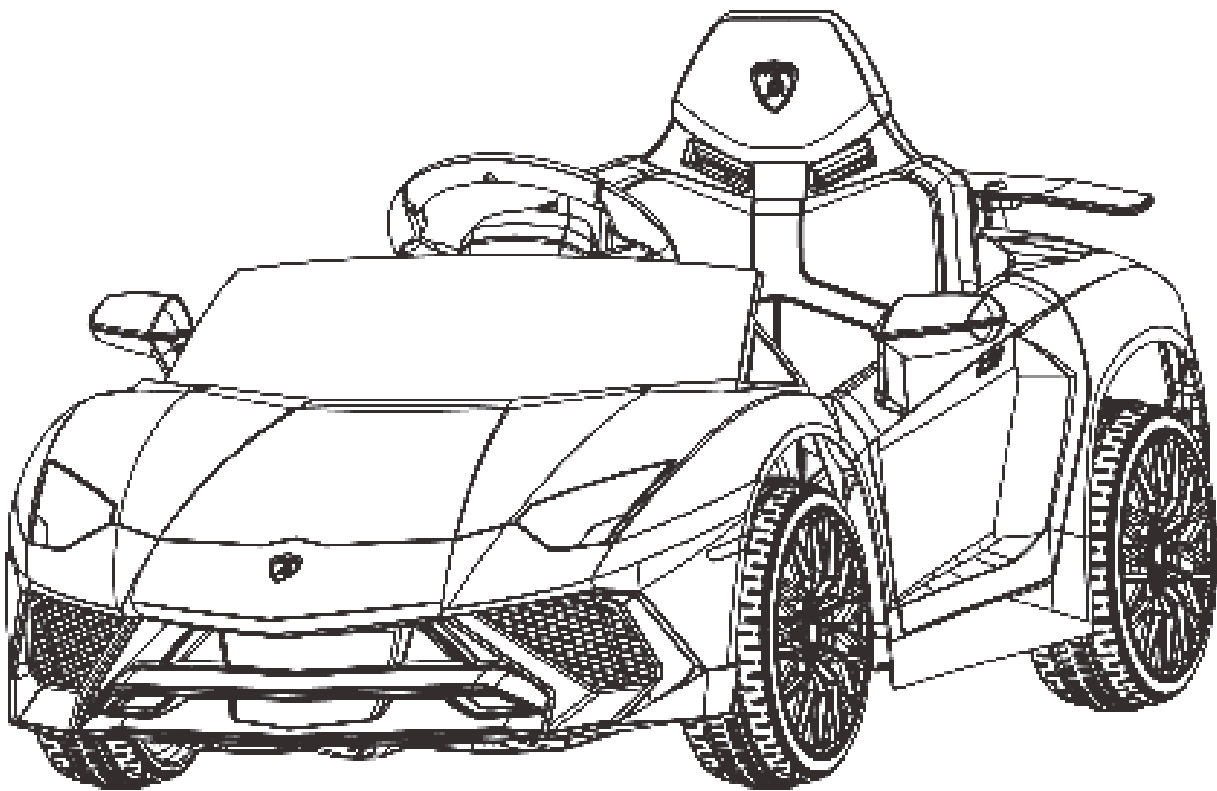

LICENSED LAMBORGHINI AVENTADOR SV RIDE ON (12V)
item number: 060-ROT-17L



Note: Product appearance and colors may vary from the photo.

⚠ ATTENTION

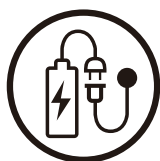

**This vehicle is packed with the battery disconnected.
Connect the battery before use.**

**This manual contains important safety, performance
and maintenance information. Read the manual before
allowing your child to ride your new electric ride-on toy.
Keep this manual properly for future reference.**

Safety Instruction

When using electrical product, basic safety precaution should always be followed including the following

⚠ WARNING:

Read all Instruction before use operating this product

- To Protect against electrical shock, do not immerse cord, charger, transformer, battery, or the product in water or other liquid.
- Only use charging devices, transformer, and battery provided or recommended by the manufacturer.
- For your children's safety, the product should be assembled by adult.
- This toy is only intended for children between 37 - 72 months of age.
- Closely adult supervision is necessary when your child is operating this product.
- Disconnect the battery if not used for a long time.
- Personal protective equipment such as helmet is needed when using operating this product.
- Do not use this product as a traffic tool.
- To reduce the risk of injury, adult supervision is required. Never use in roadways, near motor vehicles, on or near steep inclines or steps, swimming pools or other bodies of water; always wear shoes, and never allow more than 1 rider.
- Do not use this product on slippery surface.
- Always keep hands, hair, and clothing away from moving parts.
- Maximum users's weight for this product is 66 lb / 30 kg.
- Do not change, modify or add any electrical wiring on this product.
- Avoid using this product in tight environment to prevent damage to the product or injury to the user.
- Do not use this product in the dark. Only operate this product during daytime or well-lit area.
- For your child's safety, please make sure the seat belt is securely fastened when operating this product.
- Personal protective equipment such as helmet is needed when operating this product.



**CORRECT FITTING –
MAKE SURE YOUR HELMET
COVERS YOUR FOREHEAD.**



**INCORRECT FITTING –
FOREHEAD IS EXPOSED
AND VULNERABLE TO
SERIOUS INJURY.**

⚠ WARNING:

PREVENT FIRE

- Never modify the electrical system. Alterations could cause a fire resulting in serious injury and could also ruin the electrical system.
- Use of the wrong type of battery or charger could cause a fire or explosion resulting in serious injury.
- The battery must be handled by adults only. The battery is heavy and contains sulfuric acid(electrolyte). Dropping the battery could result in serious injury.
- Never allow children to charge the battery. Battery charging must be done by adults only.
- Never lift or carry the battery by the wires or connector. This can damage the battery and possibly cause a fire resulting in serious injury. Lift and carry the battery by the case only.
- Examine the battery, charger and their connectors for excessive wear or damage each time you charge the battery. If damage or excessive wear is detected, do not use the charger or the battery until you have replaced the worn or damaged part.

⚠ WARNING:

Manufacturer and seller expressly disclaim any and all liability for personal injury, property damage or loss, whether direct, indirect, or incidental, resulting from the incorrect attachment, improper use, inadequate maintenance, unapproved modification, or neglect of this product.

⚠ Avoid continuously hitting into obstacle to prevent overheat or damage to the motor, Drive away or remove obstacle as soon as possible.

Product Specification

Motor:12V, 390#, 25W*2

Charger: 12V500mA

Speed: 0.7~2.2mph(1.2~3.5km/h)

Suitable Age: 37~72months

Maximum User Weight: 66lb/30kg

Dimension: 45.27" x 25.82" x 17.71"(1150 x 656 x 450 mm)

Battery charge time: 8~12hours

First charging time: 8~12hours

Max charging time: 20hours

Battery (Temperature Tolerance) : -20°C (68°F) TO 60°C (140°F)

Operation Time: 1~2hours

Parts and Feature



A (Steering Wheel)



C (Left Mirror)



D (Right Mirror)

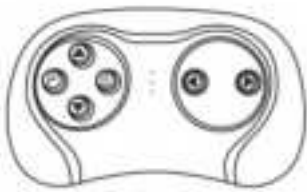

E (Remote Control)



F (Rear Wing)



G (Wheel)



H (Wheel Cover)



I (Seat)



L (Spanner)



Q (Charger)



R (Windshield)



T (M4x12 Screw)

Assembly Instruction

Estimated Assemble Time: 40 mins

Tools Needed:

Screw Driver(not included)

Some parts are small and have sharp edges. Do not let children handle parts or the assembly.
This product should be assemble by adult.

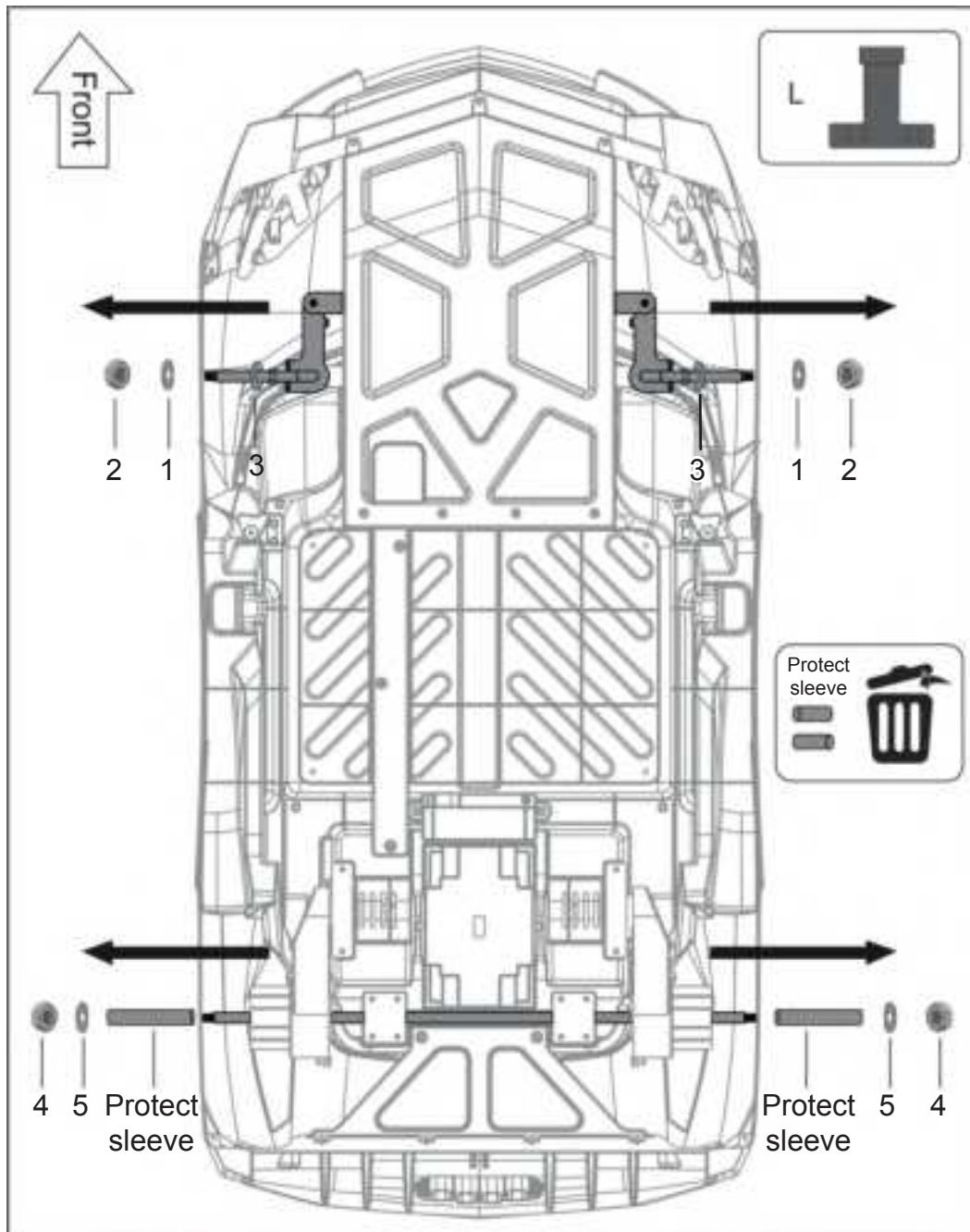

Remove Nuts (2) and Washer (1) from the front axle, and remove Nuts (4) and Washer (5) from the rear axle.

Assembly Instruction

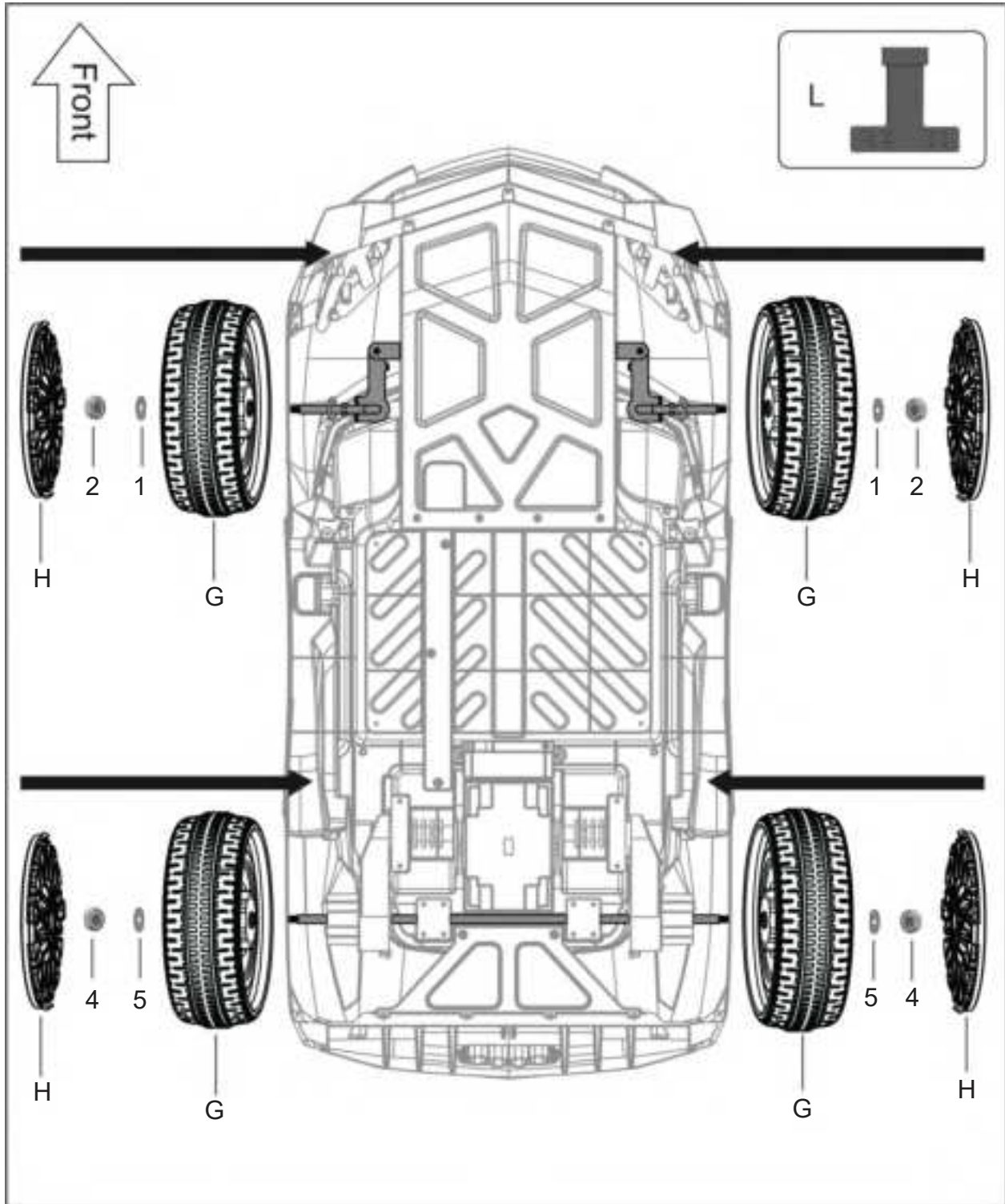

Slide Wheel (G) to the front axle and replace Washer (1) and Nut (2), then snap on Wheel Cover (H). Slide Wheel (G) to the rear axle and replace Washer (5) and Nut (4), then snap on Wheel Cover (H).

Assembly Instruction

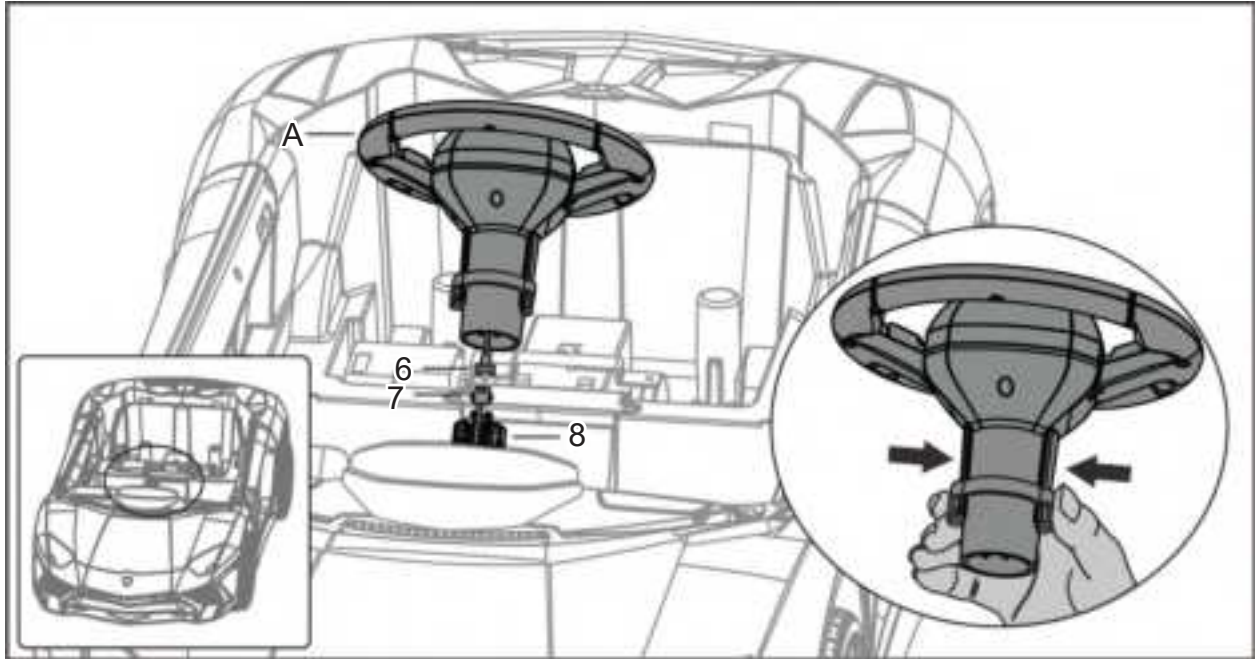

Connect terminal (6) from the Steering Wheel (A) to the terminal (7) on the Steering Column (8). Insert the Steering Wheel into the Steering Column.

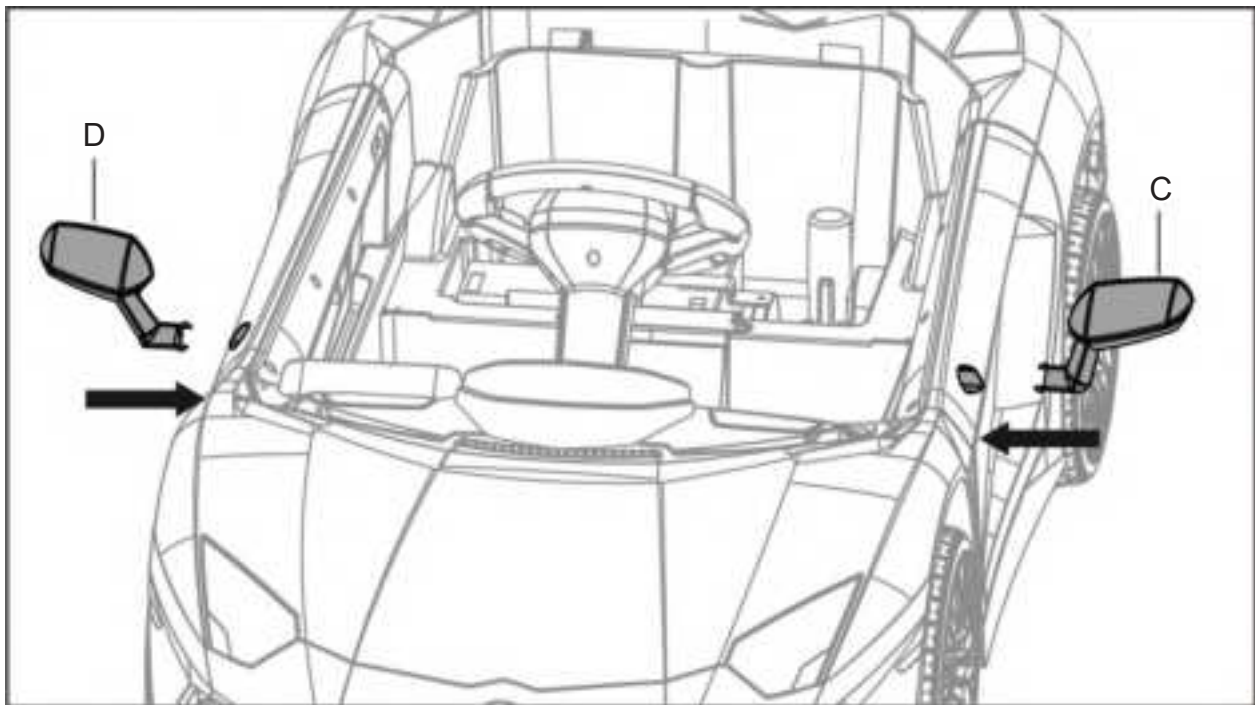

Insert Left Side Mirror (C) and Right Side Mirror (D) to the side of the vehicle.

Assembly Instruction

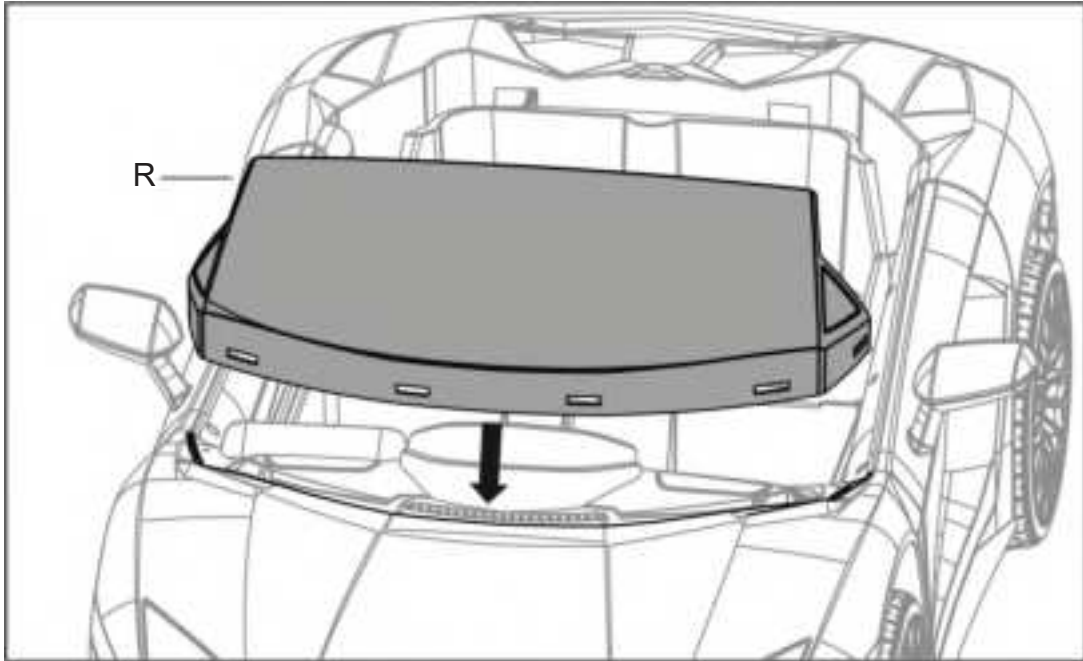

Assemble Windshield (R) to the vehicle body.

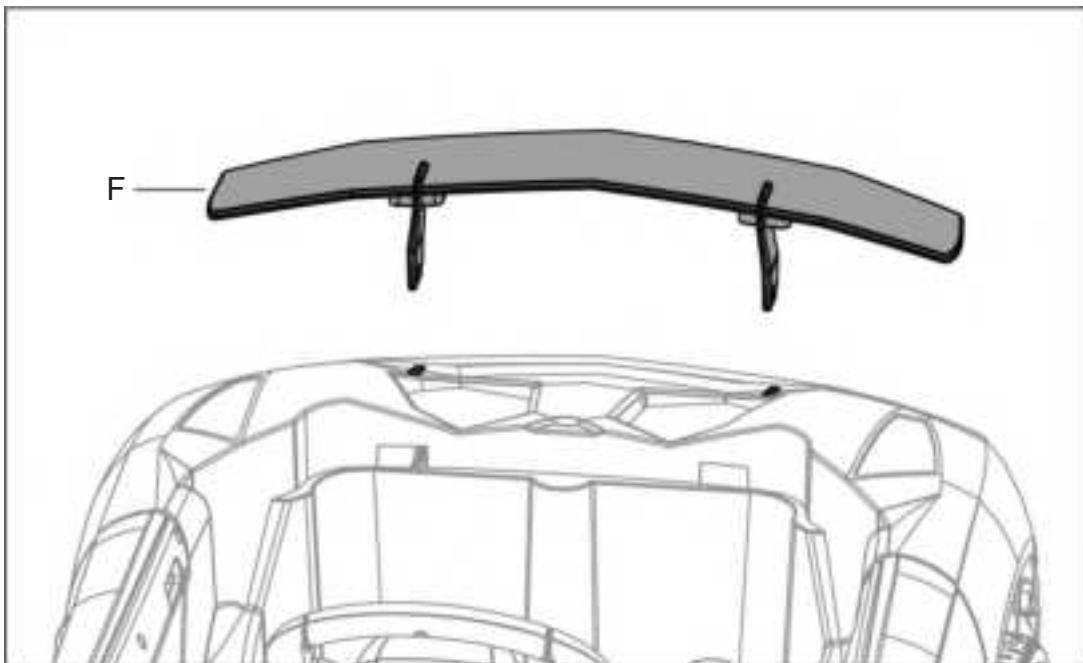

Assemble Rear Wing (F) to the two slots on the vehicle body.

Assembly Instruction

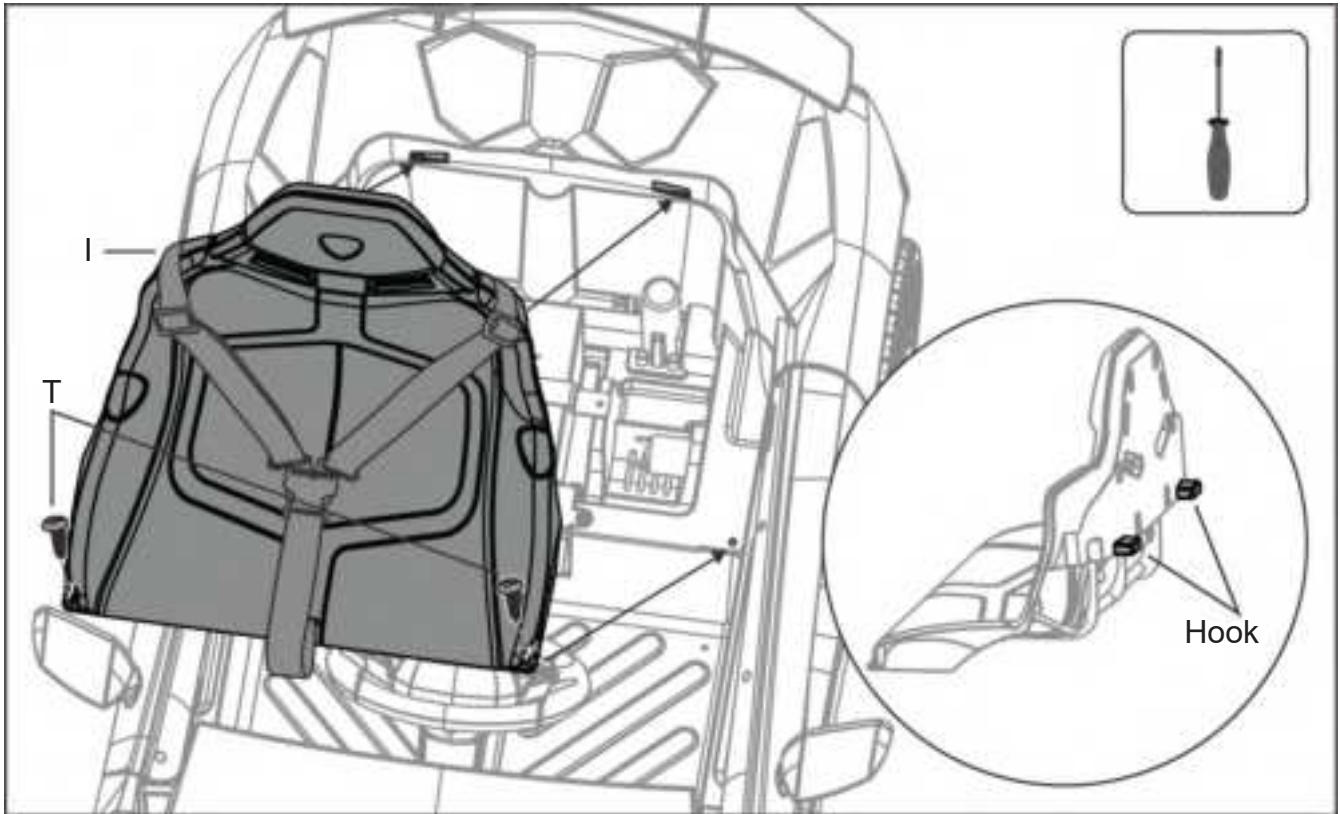

Install the seat (I) to the car and align the hooks on the back to the groove on the car body. Secure it in place with 2 M4X12 screws (T).

User Instruction

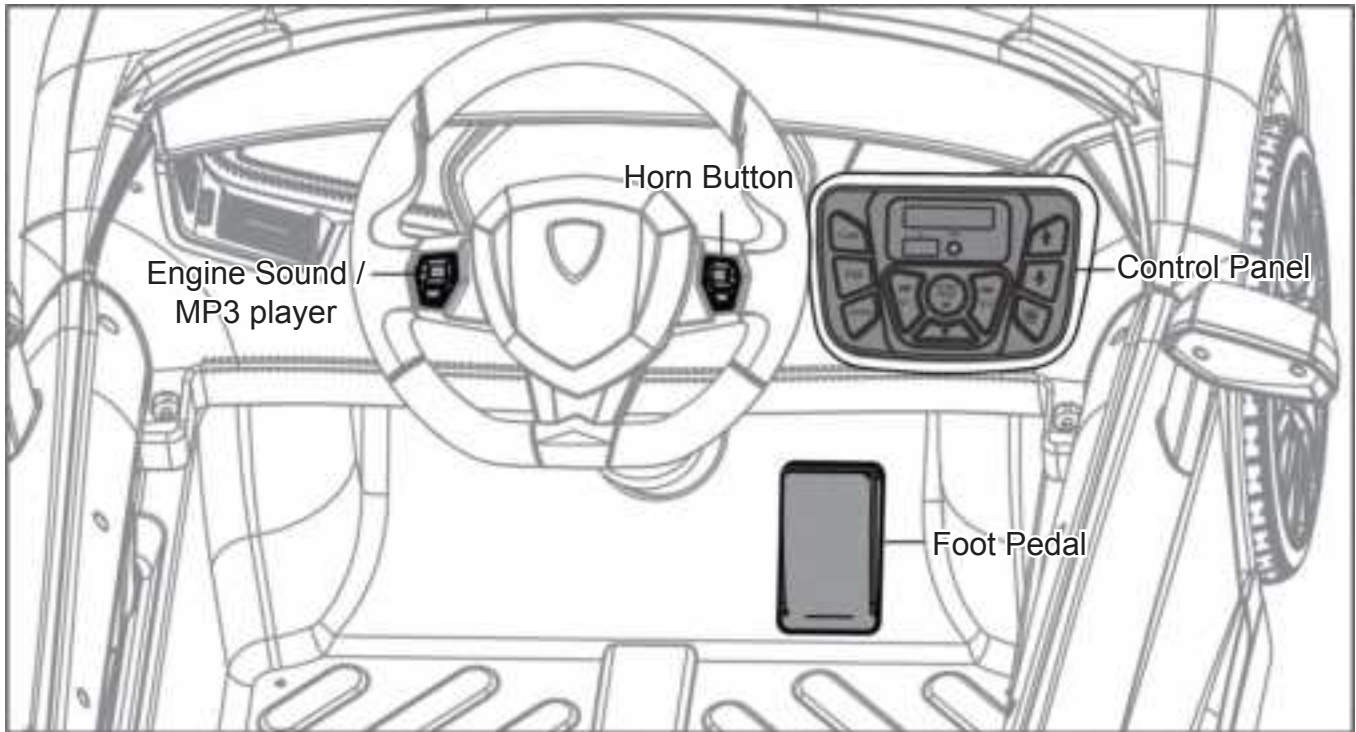

Control the vehicle

Control Panel

Control the ON / OFF of the vehicle and the audio playing system.
See detailed instruction on the Control Panel User instruction on page 10~11.

Engine Sound Button

Press the button to play the engine sound.
When USB and MP3 device is connected to the vehicle, pressing the button will play the next song.
Press and hold the button will increase volume.

Horn Button

Press the button to horn.
Press and hold the button will decrease volume.

Foot Pedal

Press the foot pedal to move the vehicle
Release the foot pedal to stop the vehicle.

User Instruction (Control Panel)

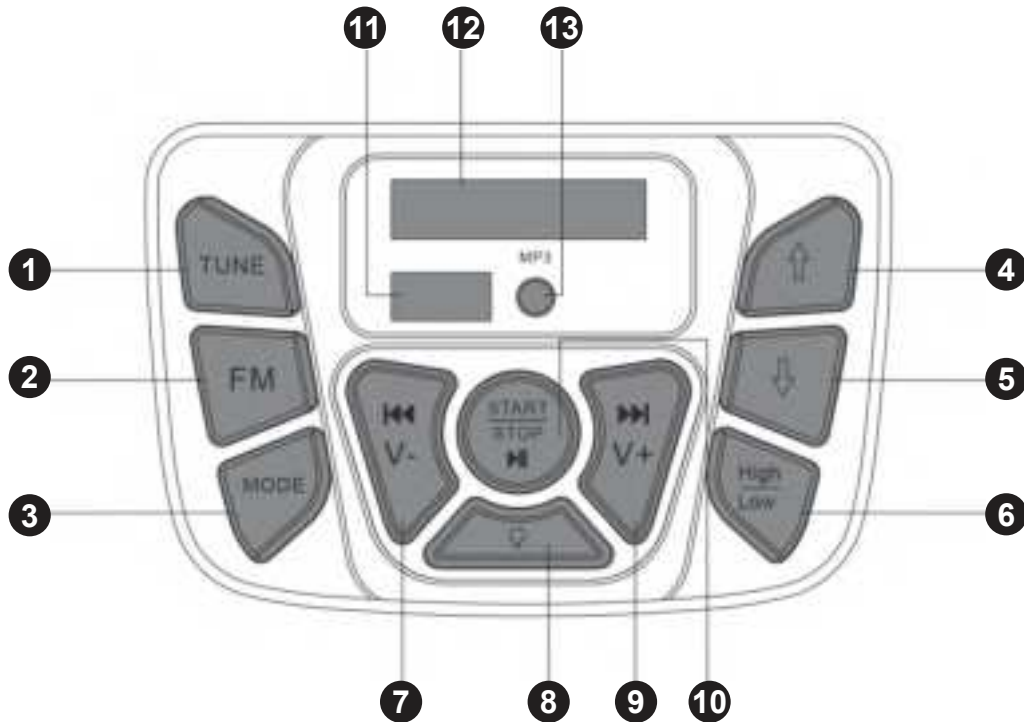

1. FM Radio Search Button

Press this button to search FM channel when in FM mode.

2. FM Button

Press the FM button to enter FM mode.

3. Mode Button

Press Mode button to switch between USB, AUX, and Bluetooth(Kidzone Ride-on).

4. Forward Button

Press the forward button, and step on the foot pedal to move the vehicle forward.

5. Reverse Button

Press the reverse button, and step on the foot pedal to move the vehicle in reverse.

6. High / Low Speed Button

Press the speed button to switch between high and low speed.

7. Previous / Decrease Volume Button

Press the button to play the previous music track.
Press and hold the button to decrease the volume.

8. Light Button

Press the button to turn ON / OFF the vehicle light.

User Instruction (Control Panel)

9. Next / Increase Volume Button

Press the button to play the next music track.
Press and hold the button to increase the volume.

10. ON/OFF Button

Press and hold the button to turn ON or OFF the vehicle.
Short press the button to pause or play music track.

11. Flash Drive Port

Port for flash drive with MP3 files.
NOTE: The player can only support MP3 format files.

12. Voltage Display Screen

The battery level will be displayed on the screen.

13. AUX Port

Connect music device to the vehicle player via AUX cable.

User Instruction (Remote Control)

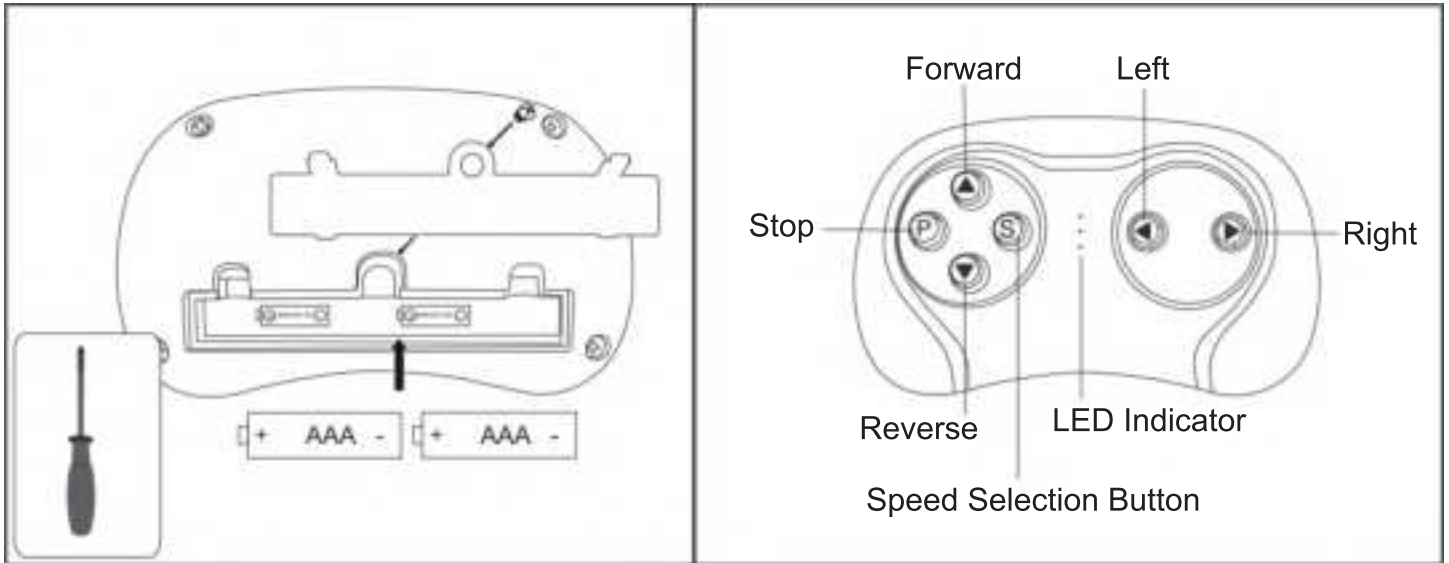

Using the remote control

The remote control should only be used by adult.

NOTE: Remote control input will always over-ride manual control operation.

Change Battery

Remove the cover on the back of the controller and insert two AAA (LR03) batteries.

NOTE: If the remote controller is not used for 10 seconds, it will shut down automatically.

Do not mix old and new batteries.

Do not mix alkaline, standard (carbon-zinc), or rechargeable batteries.

Establish Connection

1. Turn off the Power of the vehicle.
2. Insert battery into the remote control and the LED indicator will flash.
3. Turn on the Power of the vehicle. When 2 LED indicator on the remote control remain on, it indicates a successful pairing.
4. The connection will remain unless the batteries on the remote control are replaced.

Remote control will automatically enter sleep mode if not used for a long period, and the LED indicator will turn off. Press any button to wake the remote control up.

User Instruction (Charging)

⚠ WARNING!

The battery should only be charged by an adult. The battery is not replaceable.

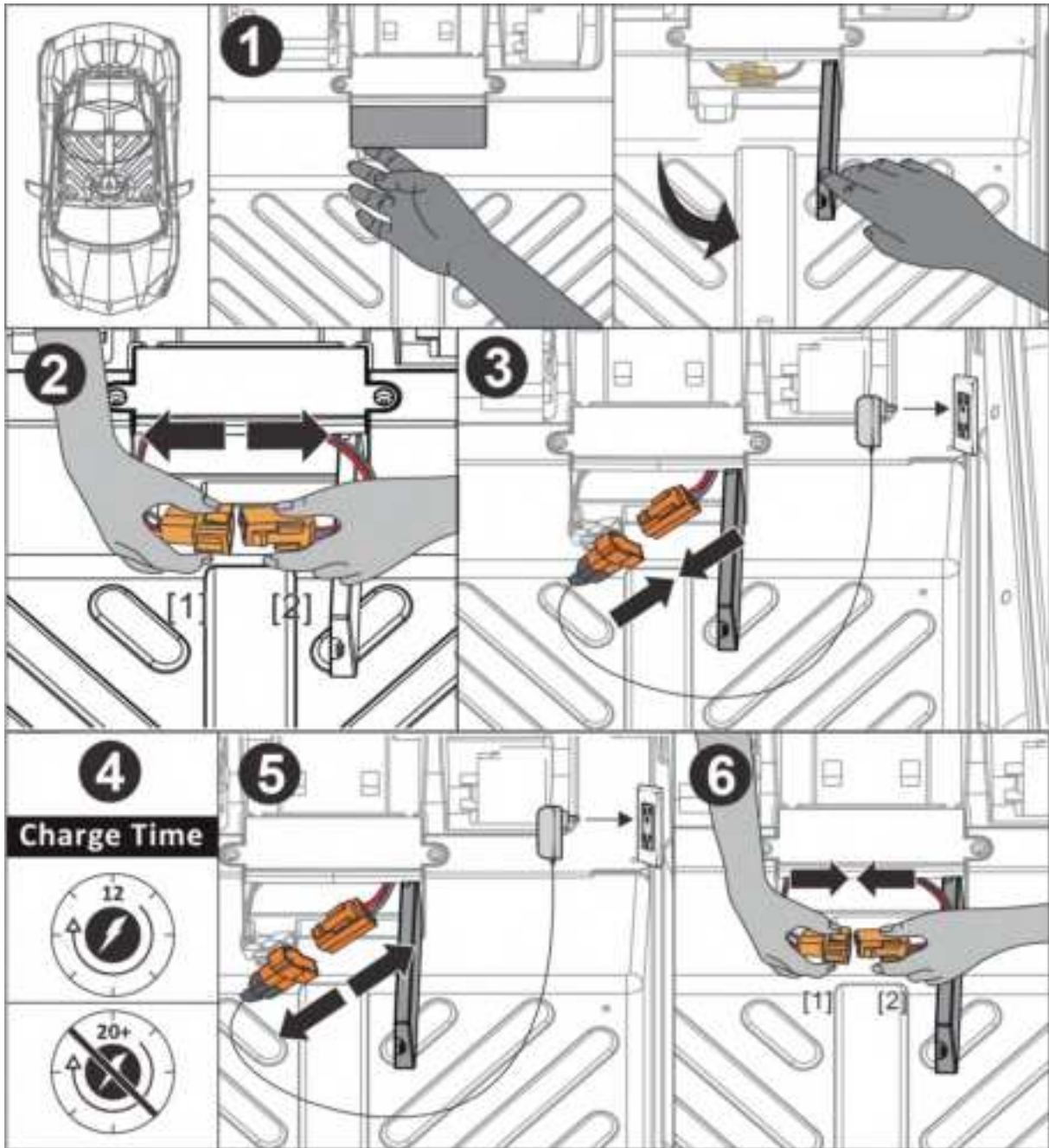

Charging the battery

- The vehicle must be OFF when charging
- Before the first use, the battery should be charged for around 12 hours. Do not charge the battery for more than 20 hours to avoid overheating or damage to the charger or the battery.
- Recharge the battery if the vehicle operates slowly.
- The battery is not replaceable.

Charge the battery at least once a month even not operating the vehicle to maximize the battery life.

Care and Maintenance

- Check the product regularly and make sure there is no missing or loose parts. Re-tighten any loose parts if necessary.
- Make sure there is no cracked or broken plastic parts.
- Keep away the product from heat and humid area, cover it with trap when not in use.
- Turn off the product and disconnect the battery if the product is not use for a long period of time.
- Clean the vehicle with a cloth. Use a non-wax furniture polish to restore the shininess of the plastic parts. Do not use abrasive cleaner.
- Do not wash the product with a hose or immerse any parts in water or other liquid.
- Occasionally use lightweight oil to lubricate moving parts

Troubleshooting

Problem	Possible Reason	Solution
Vehicle does not move	Low Battery	Fully charge the battery
	Fuse Protection	Wait 5 - 20 seconds for the fuse to reset
	Disconnected / Badly connected battery	Reconnect the battery
	Failed battery / engine	Contact Customer Service
Battery not last long	Low Battery	Fully charge the battery
	Old Battery	Replace battery if necessary
Vehicle runs very slow	Low Battery	Fully charge the battery
	Old Battery	Replace battery if necessary
	Vehicle is overloaded	Make sure user's weight is under 66 lb / 30 kg
	Vehicle is being used in harsh environment	Avoid using the vehicle in harsh environment

Troubleshooting

Problem	Possible Reason	Solution
Vehicle needs a push to go forward	Poor wire connection	Check if the battery connectors are firmly connected. Contact Customer service if necessary
	"Dead spot" on motor	Contact customer service
Loud grinding sound or clicking sound from the motor or gear box	Damaged motor or gear box	Contact customer service
Battery does not charge	Disconnected / Badly connected battery	Reconnect the battery
	Disconnected / Badly connected charger	Make sure the charger is firmly plugged into the power source and connected to the charging port
	Charger not working	Contact customer service
Charger becomes warm during charging	Normal	N/A

Model: CST-1A

FCC ID: 2ARLM-CST-1A

This device complies with part 15 of the FCC Rules. Operation is subject to the following two conditions:

(1) This device may not cause harmful interference, and

(2) this device must accept any interference received, including interference that may cause undesired operation.

NOTE: This equipment has been tested and found to comply with the limits for Class B digital device, pursuant to part 15 of the FCC rules. These limits are designed to provide reasonable protection against harmful interference in a residential installation. This equipment generates, uses and can radiate radiofrequency energy and if not installed and used in accordance with the instructions, may cause harmful interference to radio or television reception, which can be determined by turning the equipment off and on, the user is encouraged to try to correct the interference by one or more of the following measures:

-Reorient or relocate the receiving antenna.

-Increase the separation between the equipment and the receiver.

-Connect the equipment into an outlet on a circuit different from that to which the receiver is connected.

-Consult the dealer or an experienced radio/TV technical for help.

Caution: Changes or modifications not expressly approved by the party responsible for compliance could void the user's authority to operate the equipment.

This product conforms to toy safety standards CPSIA and ASTM-F963.

Importer: ONE BIG OUTLET

Importer Address: 19301 E Walnut dr. N. City of industry CA91748 united states

Importer Tel.: 800 - 946 - 6151

Limited Term Warranty (One Year from Date of Purchase)

WARRANTY TERMS

KIDZONE warrants that its merchandise are free from manufacturing defects (workmanship and/or material) and will either give credit or replace defective parts for a period of up to one (1) year from the date of purchase in accordance with the conditions set forth below. If a manufacturing defect is found, KIDZONE should be notified promptly of the defect and supplied a copy of the invoice and delivery ticket. Inspection by a KIDZONE employee or representative may be necessary to verify that a manufacturing defect exists, or you may be required to submit samples to KIDZONE along with a digital image of the defects. If replacement is required in accordance with this warranty and the defective material or merchandise has been discontinued or unavailable, KIDZONE reserves the right to select and supply similar merchandise or offer full credit for the merchandise; otherwise the same material or merchandise will be supplied for replacement purposes. This warranty is made solely to the retailer and is not transferable under any circumstances. It is the retailer's responsibility to contact KIDZONE with a claim. We will not handle claims from consumers directly; all requests must go through the retailer who sold the merchandise to the consumer. We advise all retailers to retain invoices for a minimum of one (1) year for warranty purposes. This warranty supersedes and replaces all implied warranties of merchantability and use for particular purpose. No representative, employee, agent or any other person is authorized to assume for KIDZONE any additional liability or responsibility in connection with KIDZONE's merchandise except as described above. Implied warranties or merchantability and fitness of the merchandise are limited to a period of one (1) year from the date of purchase. In no event shall KIDZONE be liable for indirect, consequential or incidental damages of any kind.

ADDITIONAL CONDITIONS

THE FOLLOWING EXAMPLES ARE NOT MANUFACTURER'S DEFECTS:

- Colors may vary slightly from the photo because of photography and printing tolerances.
- Sizes stated in U.S. standard measurements may vary slightly due to product are manufactured using the metric system.
- No returns for buyer's remorse.
- No returns - other than stated above will be accepted.

ADDITIONAL CONDITIONS

WARRANT IS VOID FOR ANY OF THE FOLLOWING CONDITIONS:

1. Improper maintenance or improper use resulting in damage.
2. Any product modifications by dealer, consumer, or other parties not authorized by KIDZONE will void this warranty.
3. Floor samples sold or products designated "AS IS" at the time of purchase are not covered by the warranty
4. Warranty does not cover minor variations or differences between floor samples or printed illustrations and your product.
5. Cost of packaging and shipping to and from KIDZONE is not covered by the warranty unless expressly arranged by KIDZONE.
6. This warranty covers only articles of appliances intended for residential use only, does not cover any industrial, commercial, institutional or Rental use.
7. Dissatisfaction due to buyer's remorse.
8. Normal wear and tear.
9. Damages incurred during transportation.
10. Damages incurred during assembling or maintenance.
11. Damage incurred by accidents or abuse.