

LEITNER

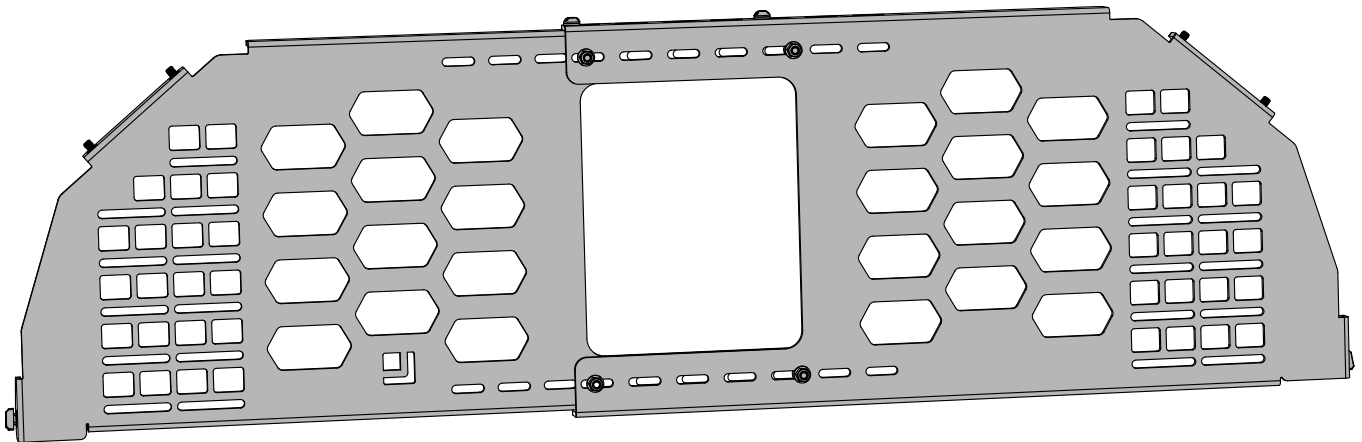

ACS FORGED HEADBANGER

LEITNERDESIGNS.COM | SALES@LEITNERDESIGNS.COM | 949-395-3049

ASSEMBLY / INSTALLATION INSTRUCTIONS:

PART NUMBERS:

00-HBA-1823

TOOLS REQUIRED

- TORQUE WRENCH
- T40 TORX BIT SOCKET
- 13MM WRENCH

INSTALLATION TIME

1 HOUR

BASIC KNOWLEDGE OF HAND TOOLS REQUIRED

SKILL LEVEL



2= NOVICE

▼ READ BEFORE INSTALLING LOAD BAR ▼

1. DON'T OVER-TIGHTEN BOLTS. ALL 8MM BOLTS = (16FT-LB)

2. LAY DOWN A LARGE AREA OF CARPET OR BLANKETS AS A WORK AREA TO AVOID SCRATCHING PARTS DURING ASSEMBLY.

▼ ASSEMBLY OVERVIEW ▼

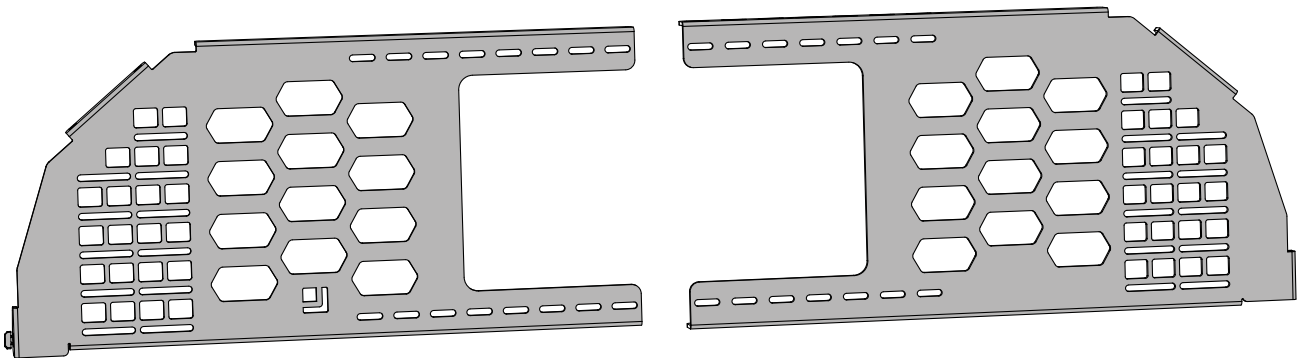

▼ ACS FORGED HEADBANGER HARDWARE ▼

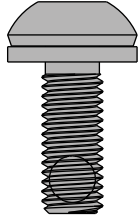

M8 X 20
(X6)

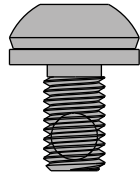

M8 X 14
-(X6)-

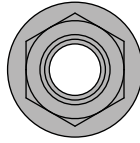

M8 LOCKNUT
(X6)

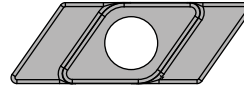

DROP IN NUT
(X2)

MEASURE: MEASURE BELOW FOR PROPER FIT

•PRIOR TO INSTALLING HEADBANGER YOU WILL NEED TO ADJUST THE WIDTH OF THE ASSEMBLY SO THE LOWER MOUNTING FLANGES FIT BETWEEN THE LOWER MOUNTING RAILS ON THE RACK. THIS DOES NOT HAVE TO BE PERFECT AT THIS STAGE BUT WITHIN 3/8 OF AN INCH WILL DO THE JOB. (FIG 1)

•INSTALL SIX M8 X 20 BOLTS THROUGH THE FURTHEST APPART SLOTS POSSIBLE. FIX IN PLACE USING A M8 LOCKNUT. DO NOT TIGHTEN AT THIS TIME. (FIG 2)

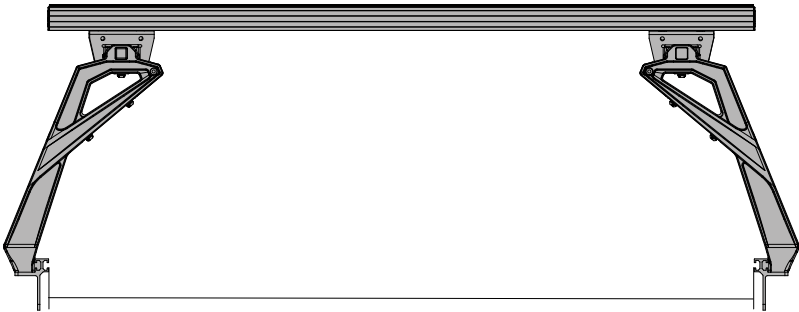

THE DISTANCE BETWEEN THE INSIDE RAILS ON THE ACS AND FLANGES ON THE HEADBANGER SHOULD MATCH AS CLOSE AS POSSIBLE BEFORE INSTALLING SIX BOLTS BELOW. USE A TAPE MEASURE TO MEASURE THE INSIDE RAILS AND THEN MATCH THAT MEASUREMENT TO THE FLANGES ON THE HEADBANGER

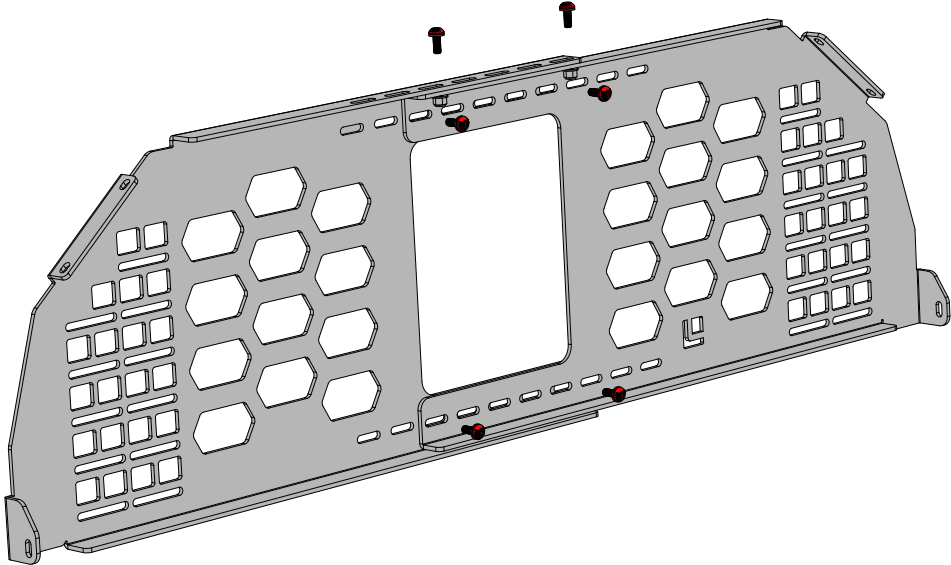
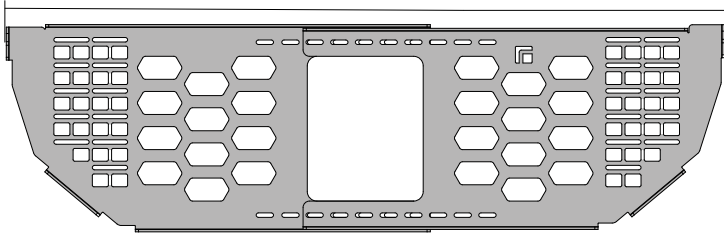

INSTALL: LOWER RAIL FASTENERS

INSTALL A M8 X 14 BOLT AND 1/4 TURN TRAKLOCK FASTER INTO EACH LOWER MOUNTING FLANGE AS SHOWN BELOW.

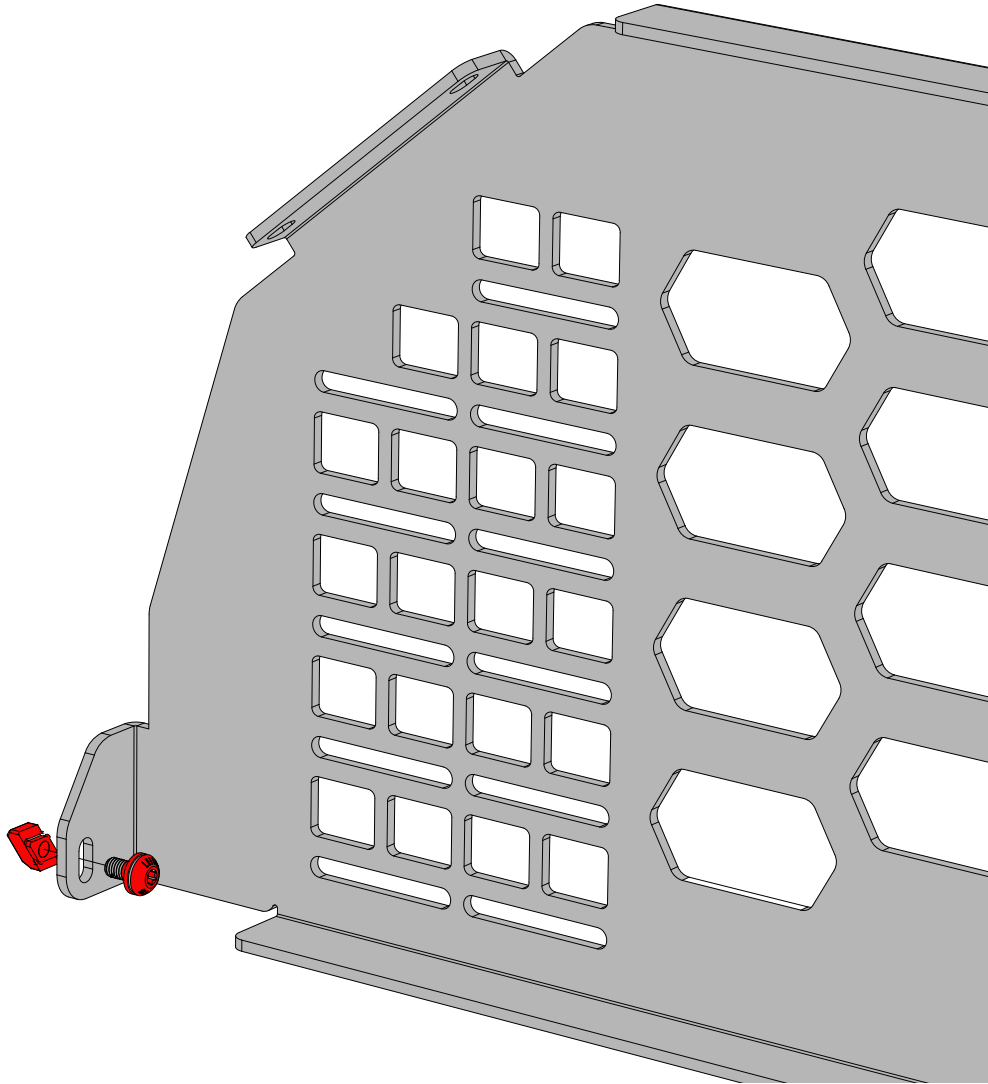

REMOVE: REMOVE SCREWS FROM UPRIGHTS

- REMOVE THE TWO (2) SCREWS ON THE INSIDE FROM BOTH UPRIGHTS THAT YOU ARE INSTALLING THE HEADBANGER TOO.
- DEPENDING ON WHEN YOUR RACK WAS PRODUCED YOU WILL EITHER NEED A 5MM ALLEN WRENCH OR A T40 TORX WRENCH. IF YOU HAVE THE 5MM ALLEN HEAD SCREWS WE RECOMMEND REPLACING THEM WITH THE M8 X 14 TORX HEAD SCREWS SUPPLIED.

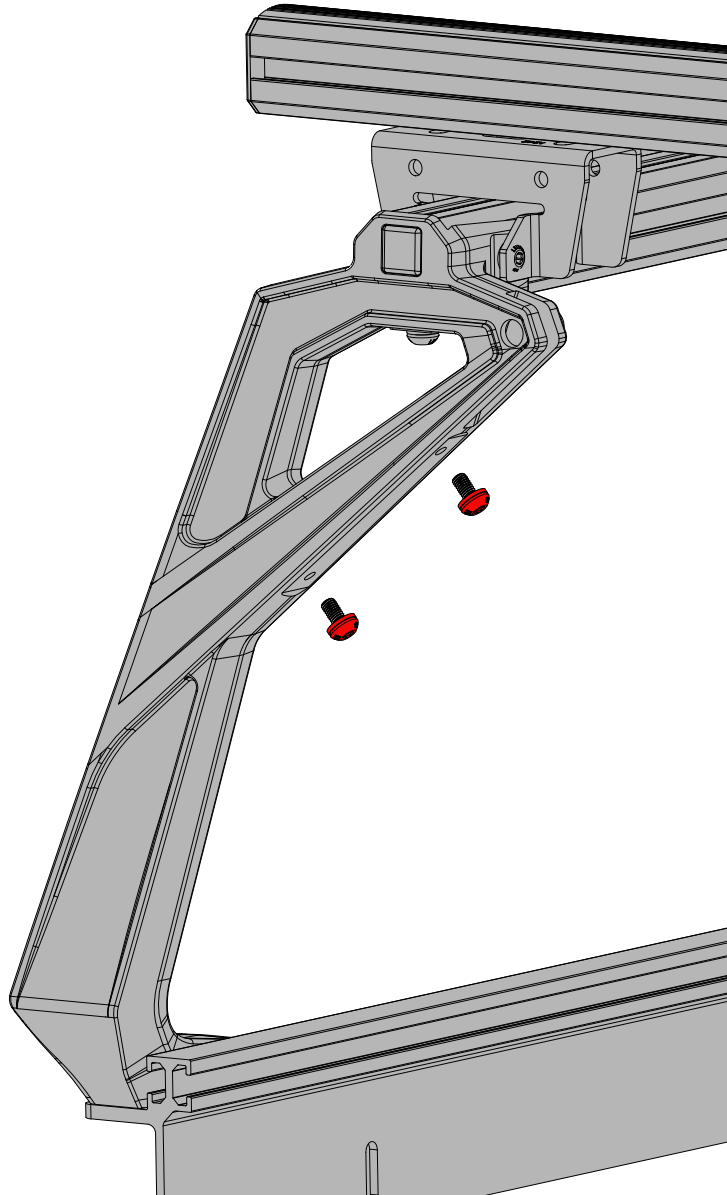

INSTALL: HEADBANGER TO RACK - PART 1

- FOR THIS STEP IT IS BEST TO HAVE ALL PREVIOUSLY INSTALLED ACCESSORIES REMOVED SO YOU CAN EASILY PLACE THE HEADBANGER INTO POSITION.
- ON BOTH SIDES OF THE HEADBANGER SLIDE THE TRACKLOK BOLT INTO THE LOWER RAIL. **DO NOT TIGHTEN AT THIS TIME.**

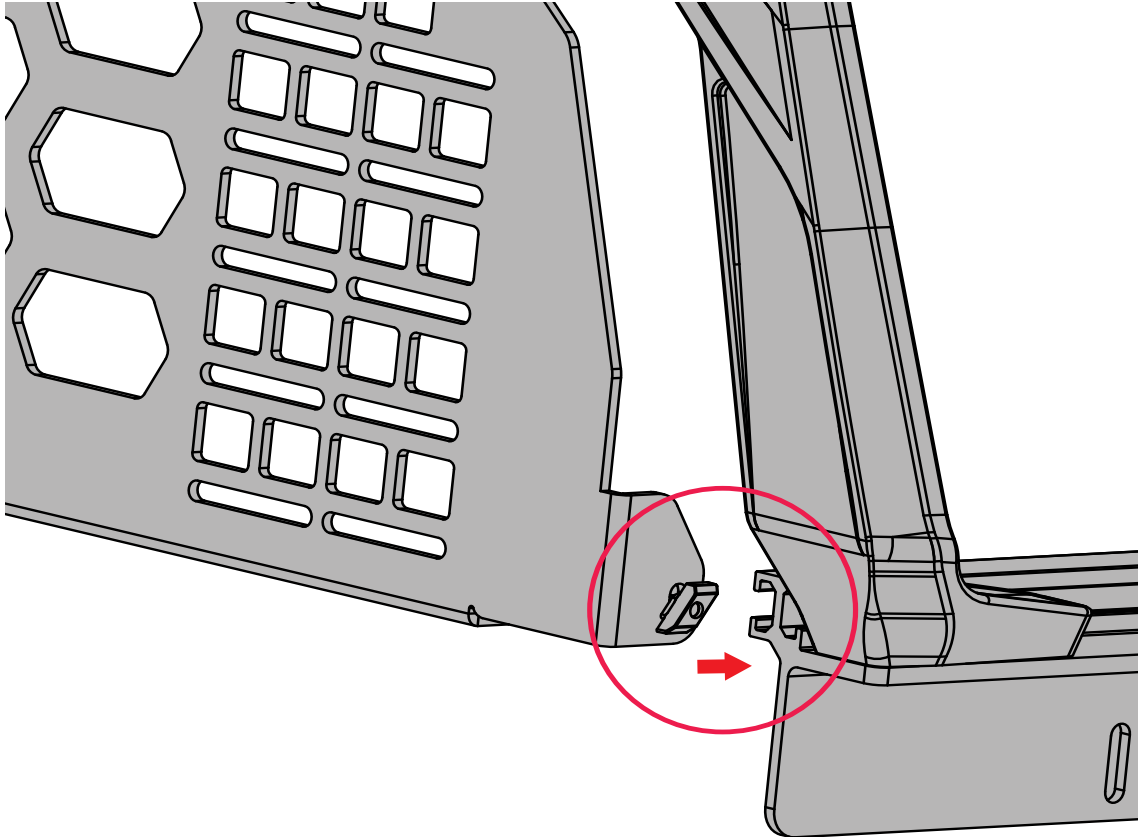

SECURE: TIGHTEN ALL BOLTS

- INSTALL THE FOUR M8 X 14 BOLTS AS SHOWN ON BOTH SIDES OF THE HEADBANGER
- FULLY TIGHTEN THESE BOLTS FIRST. (STEP 1) THEN TIGHTEN THE TRACKLOCK FASTENER ON THE LOWER RAIL (STEP 2)

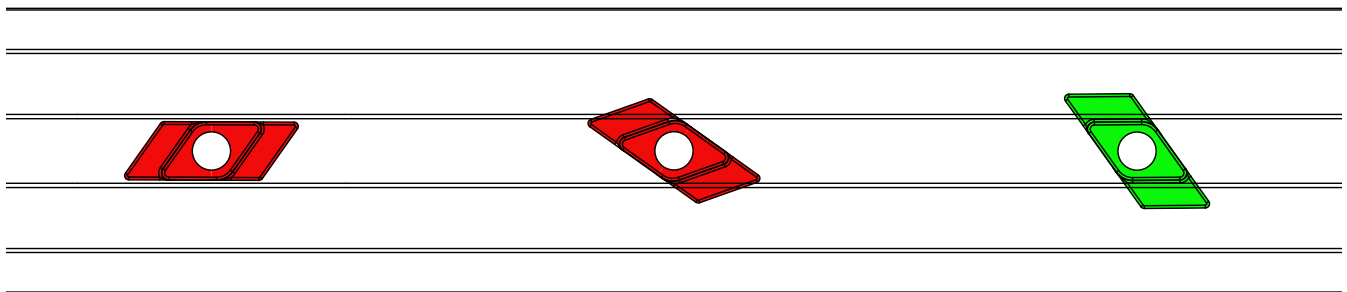
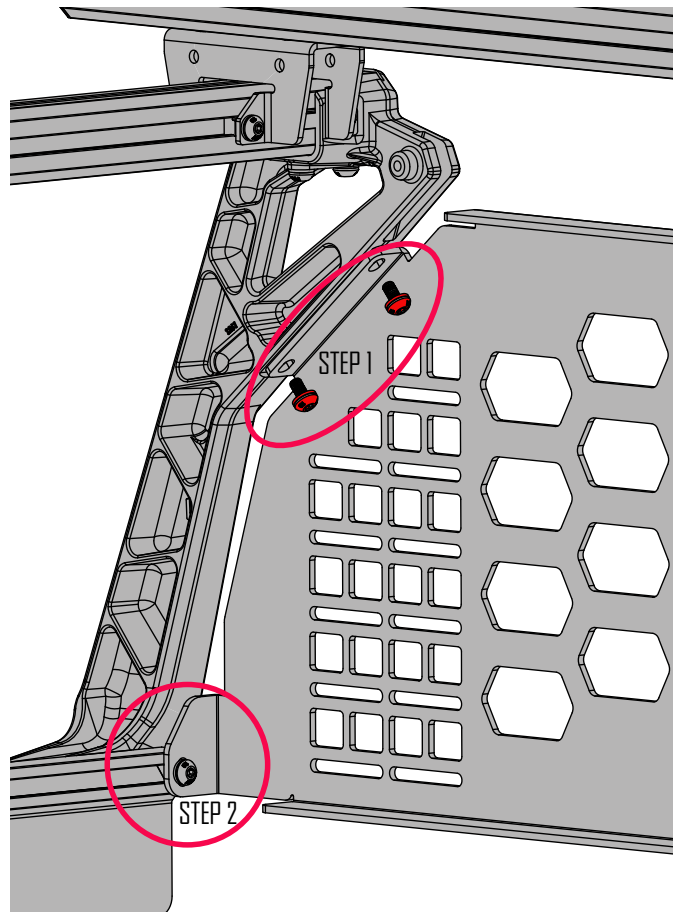

BAD

BAD

GOOD

• NOTE: IT IS EXTREMELY IMPORTANT THAT THE TRAKLOK NUTS ROTATE FULLY INTO PLACE AS SHOWN IN DIAGRAM AND TIGHTEN DOWN UNDER THE LIP OF THE ALUMINUM EXTRUSION.

INSTALL: HEADBANGER TO RACK - PART 2

• TIGHTEN ALL 6 BOLTS BELOW USING A T40 TORX AND 13MM WRENCH.

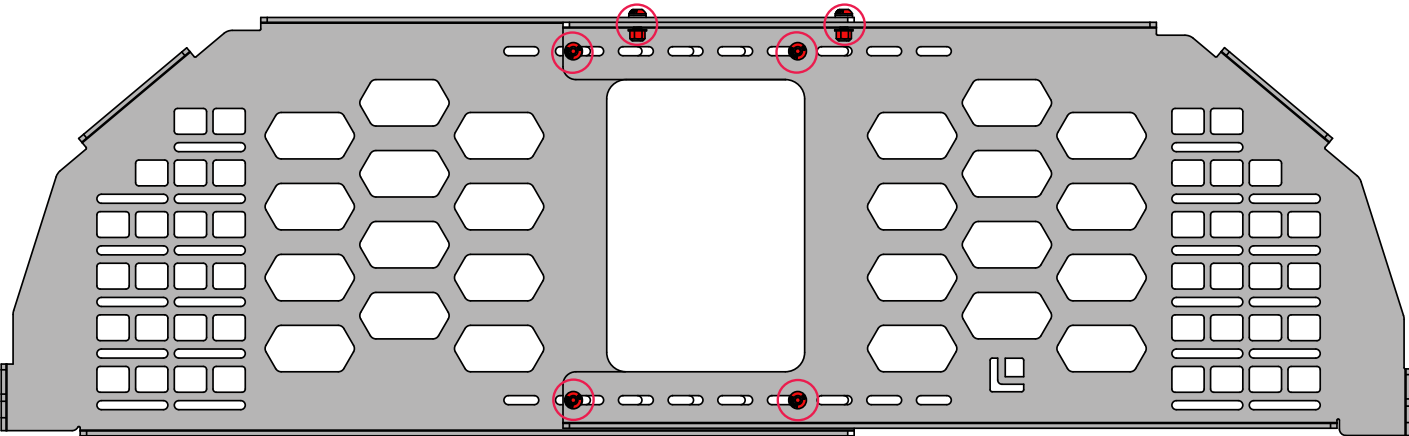

USE GUIDELINES

WHEN USING LEITNER DESIGNS CARRIERS AND ACCESSORIES, THE USER MUST UNDERSTAND THE PRECAUTIONS. THE POINTS LISTED BELOW WILL ASSIST YOU IN USING THE RACK SYSTEM AND WILL ENCOURAGE SAFETY.

-FOR QUALITY FITS AND SAFETY, USE ONLY THE RECOMMENDED RACK OR ACCESSORIES. DO NOT ASSUME A RACK WILL FIT, ALWAYS CHECK THE CURRENT FIT GUIDE WHEN OBTAINING A NEW VEHICLE.

-THE MAXIMUM LOAD IS NOT TO BE EXCEEDED 75#. HOWEVER, **THIS LIMIT IS ALWAYS SUBORDINATE TO THE MAXIMUM LOAD RECOMMENDED BY THE MANUFACTURER OF THE VEHICLE ITSELF.** IT IS ALWAYS THE LOWER MAXIMUM RECOMMENDED LOAD THAT APPLIES. $\text{MAX TRUCK LOAD} = \text{LOAD CARRIER WEIGHT} + \text{ANY FITTED CARRIER ACCESSORIES} + \text{THE WEIGHT OF THE LOAD ITSELF.}$

-HIGH SPEED OFF ROAD DRIVING EVEN WITH A LIGHT LOAD CAN CAUSE DAMAGE TO THE RACK, ACCESSORIES AND VEHICLE BODY. DAMAGE CAUSED BY HIGH SPEED DRIVING AND ABUSE IS NOT COVERED UNDER WARRANTY.

-MAKE SURE ALL KNOBS, BOLTS, SCREWS, STRAPS, AND LOCKS ARE FIRMLY ATTACHED, TIGHTENED AND LOCKED BEFORE EVERY TRIP. KNOBS, BOLTS, SCREWS, STRAPS AND LOCKS MUST BE PERIODICALLY INSPECTED FOR SIGNS OF WEAR, CORROSION, AND FATIGUE. CHECK YOUR LOAD AT STOPS DURING THE TRIP TO ENSURE CONTINUED FASTENING SECURITY.

-CHECK LOCAL AND STATE LAWS GOVERNING PROJECTION OF OBJECTS BEYOND THE PERIMETER OF A VEHICLE. BE AWARE OF THE WIDTH AND HEIGHT OF YOUR CARGO SINCE LOW CLEARANCE BRANCHES, BRIDGES, AND PARKING GARAGES CAN AFFECT THE LOAD. ALL CARGO WILL AFFECT THE VEHICLE'S DRIVING BEHAVIOR. NEVER DRIVE WITH ANY LOCK, KNOB OR RACK IN AN OPEN OR UNLOCKED POSITION. ALL LONG LOADS SUCH AS, BUT NOT LIMITED TO, SAILBOARDS, SURFBOARDS, KAYAKS, CANOES, AND LUMBER MUST BE TIED DOWN FRONT AND REAR TO THE BUMPERS OR TOW HOOKS OF THE VEHICLE.

-ALL LOCKS MUST BE TURNED AND MOVED PERIODICALLY TO ENSURE SMOOTH OPERATION. USE GRAPHITE OR DRY LUBRICANT TO HELP THIS. LEITNER DESIGNS LOCKS ARE DESIGNED TO DETER VANDALISM AND THEFT BUT SHOULD NOT BE CONSIDERED THEFT PROOF. REMOVE VALUABLE GEAR IF YOUR VEHICLE IS UNATTENDED FOR AN EXTENDED PERIOD. PLACE AT LEAST ONE KEY IN THE GLOVE COMPARTMENT.

-FOR SAFETY TO YOUR VEHICLE AND RACK SYSTEM, OBEY ALL POSTED SPEED LIMITS AND TRAFFIC CAUTIONS. ADAPT YOUR SPEED TO THE CONDITIONS OF THE ROAD AND THE LOAD BEING CARRIED.

-DO NOT USE LEITNER DESIGNS LOAD CARRIERS AND ACCESSORIES FOR PURPOSES OTHER THAN THOSE FOR WHICH THEY WERE DESIGNED. DO NOT EXCEED THEIR CARRYING CAPACITY. FAILURE TO FOLLOW THESE GUIDELINES OR THE PRODUCT'S INSTRUCTIONS WILL VOID THE WARRANTY.

WARRANTY

LEITNER DESIGNS WARRANTS PRODUCT TO BE FREE FROM DEFECTS IN MATERIAL AND WORKMANSHIP, FOR TERMS SPECIFIED BELOW, PROVIDED THERE HAS BEEN NORMAL USE AND PROPER MAINTENANCE. ALL REMEDIES UNDER THIS WARRANTY ARE LIMITED TO THE REPAIR OR REPLACEMENT OF ANY ITEM FOUND BY THE FACTORY TO BE DEFECTIVE WITHIN THE TIME PERIOD SPECIFIED. IF YOU HAVE A WARRANTY CLAIM, FIRST YOU MUST CALL OUR FACTORY AT THE NUMBER BELOW FOR INSTRUCTIONS. YOU MUST RETAIN PROOF OF PURCHASE AND SUBMIT A COPY WITH ANY ITEMS RETURNED FOR WARRANTY WORK. UPON COMPLETION OF WARRANTY WORK, IF ANY, WE WILL RETURN THE REPAIRED OR REPLACED ITEM OR ITEMS TO YOU FREIGHT PREPAID. DAMAGE TO OUR PRODUCTS CAUSED BY ACCIDENTS, FIRE, VANDALISM, NEGLIGENCE, MIS-INSTALLATION, MISUSE, ACTS OF GOD, OR BY DEFECTIVE PARTS NOT MANUFACTURED BY US, IS NOT COVERED UNDER THIS WARRANTY.

THE WARRANTY TIME PERIOD IS AS FOLLOWS: (2) TWO YEARS FROM DATE OF PURCHASE.

HIGH SPEED OFF ROAD DRIVING EVEN WITH A LIGHT LOAD CAN CAUSE DAMAGE TO THE RACK, ACCESSORIES AND VEHICLE BODY. DAMAGE CAUSED BY HIGH SPEED OFF ROAD DRIVING AND ABUSE IS NOT COVERED UNDER WARRANTY.

ANY IMPLIED WARRANTIES OF MERCHANTABILITY AND/OR FITNESS FOR A PARTICULAR PURPOSE CREATED HEREBY ARE LIMITED IN DURATION TO THE SAME DURATION AND SCOPE AS THE EXPRESS WRITTEN WARRANTY. OUR COMPANY SHALL NOT BE LIABLE FOR ANY INCIDENTAL OR CONSEQUENTIAL DAMAGE.

SOME STATES DO NOT ALLOW LIMITATIONS ON HOW LONG AN IMPLIED WARRANTY LASTS, OR THE EXCLUSION OR LIMITATION OF INCIDENTAL OR CONSEQUENTIAL DAMAGES, SO THE ABOVE LIMITATIONS OR EXCLUSIONS MAY NOT APPLY TO YOU. THIS WARRANTY GIVES YOU SPECIFIC LEGAL RIGHTS, AND YOU MAY ALSO HAVE OTHER RIGHTS THAT VARY FROM STATE TO STATE.

FOR WARRANTY ISSUES WITH THIS PRODUCT PLEASE CALL LEITNER DESIGNS CUSTOMER SERVICE **949-395-3049** OR EMAIL US AT **SALES@LEITNERDESIGNS.COM**