

LEITNER



INEOS GRENADIER LOAD BAR

LEITNERDESIGNS.COM | SALES@LEITNERDESIGNS.COM | 949-395-3049

ASSEMBLY / INSTALLATION INSTRUCTIONS:

PART NUMBERS:

00-GLB2X-1753 (2 LOAD BAR KIT)

00-GLB1X-1752 (SINGLE LOAD BAR KIT)

TOOLS REQUIRED

- TORQUE WRENCH
- T30 TORX BIT SOCKET
- 13MM WRENCH

INSTALLATION TIME

1 HOUR

BASIC KNOWLEDGE OF HAND TOOLS REQUIRED

SKILL LEVEL



2= NOVICE

▼ READ BEFORE INSTALLING ACS ROOF ▼

1. DON'T OVER-TIGHTEN BOLTS. ALL 8MM BOLTS = (16FT-LB)

2. LAY DOWN A LARGE AREA OF CARPET OR BLANKETS AS A WORK AREA TO AVOID SCRATCHING PARTS DURING ASSEMBLY.

3. ALTHOUGH THE ACS LOAD BAR KIT IS LIGHT HAVING A FRIEND TO HELP IS RECOMMENDED.

▼ ASSEMBLY OVERVIEW ▼

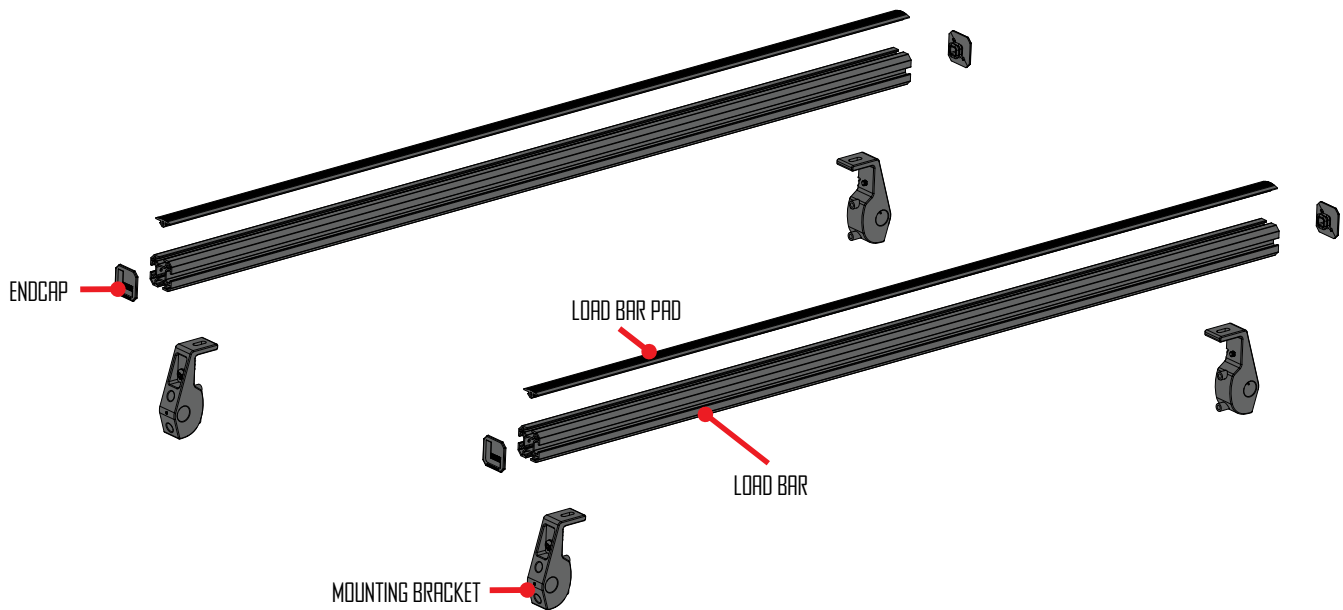

▼ ACS ROOF HARDWARE ▼

NOTE: THE SINGLE LOAD BAR HAS 1/2 THE HARDWARE AS THE 2X LOAD BAR KIT

00-GLB2X-1753 (2 LOAD BAR KIT)

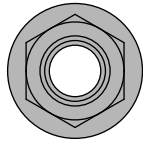

M8 LOCKNUT
(X4)

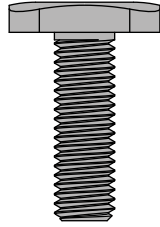

M8 T-BOLT
(X4)

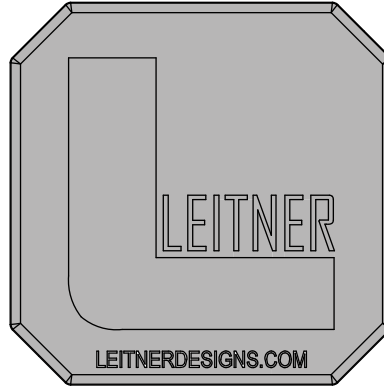

ENDCAP
(X4)

00-GLB1X-1752 (SINGLE LOAD BAR KIT)

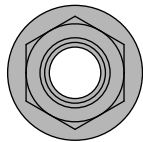

M8 LOCKNUT
(X2)

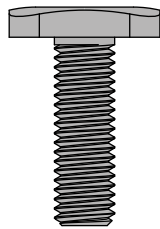

M8 T-BOLT
(X2)

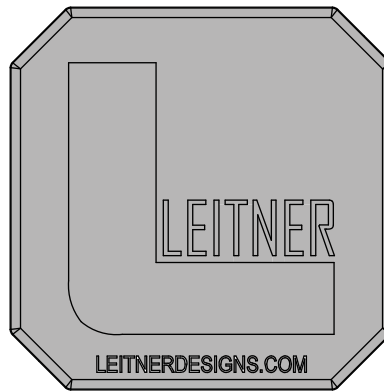

ENDCAP
(X2)

REMOVE: HAND RAILS AND BRACKETS

- REMOVE ALL HAND RAIL BRACKETS USING A T30 WRENCH. THERE IS A TOTAL OF 12 BRACKETS AND 24 SCREWS.



INSTALL: MOUNTING BRACKETS

• REMOVE THE FACTORY BRACKETS AND INSTALL LEITNER MOUNTING BRACKETS AS SHOWN IN IMAGE BELLOW.

• MAKE SURE TAB ON FACTORY BRACKET IS ORIENTATED DOWN. (RED ARROW) WHEN REINSTALLING

• DEPENDING HOW MANY LOAD BARS YOU PURCHASED YOU CAN REPLACE EVERY FACTORY BRACKET WITH A LOAD BAR.

• NOTE: IF YOU PURCHASED 2 LOAD BARS AND ARE PLANNING ON CARRYING A ROOF TOP TENT WE RECOMMEND THEY BE PLACED AS FAR APART AS POSSIBLE. (ONE AT THE FIRTHEST FRONT GRAB HANDLE BRACKET AND ONE ON THE FIRTHEST REAR GRAB HANDLE BRACKET. EXTRA LOAD BARS SHOULD BE PLACED AS CLOSE TO CENTER AS POSSIBLE TO SUPPORT THE TENT.



INSTALL: MOUNTING BRACKETS

- INSTALL ASSEMBLY FROM LAST STEP AS SHOWN.
- MAKE SURE TAB ON CENTER FACTORY BRACKET IS ORIENTATED DOWN.

NOTE: PLEASE USE SUPPLIED BLUE THREADLOCKER ON ALL FACTORY M6 BOLTS

- TIGHTEN ALL 6MM SCREWS TO 10 FT-LB (13NM) RED CIRCLES
- SNUG DOWN THE 5MM SET SCREWS USING A 3MM ALLEN WRENCH. (GREEN CIRCLES)

NOTE: IMAGE BELOW SHOWS BOTH BRACKETS ON ONE GRAB HANDLE. IF YOU ONLY HAVE 2 LOAD BARS PUT ONE ON THE REAR AND ONE ON THE FRONT SPACED AS FAR APART AS POSSIBLE TO SUPPORT THE LOAD. EXTRA LOAD BARS CAN ALWAYS BE ADDED FOR A MAXIMUM OF 6.



INSTALL: LOAD BARS

- INSTALL 2 T-BOLTS INTO ONE RAIL PER LOAD BAR
- ALIGN THE LOAD BARS SO THAT THEY ARE CENTERED ON THE VEHICLE.
- TORQUE ALL M8 LOCKNUTS TO 16 FT-LB USING A 13MM WRENCH.

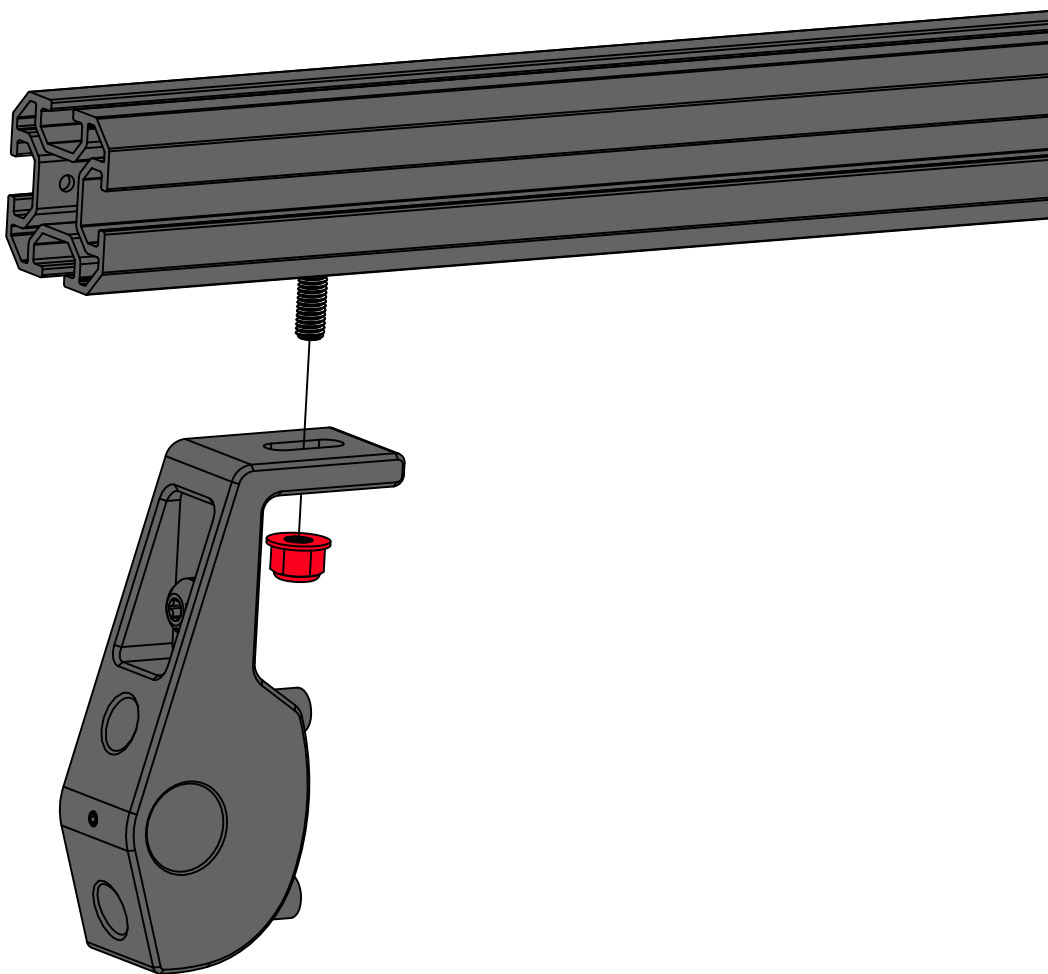

INSTALL: LOAD BARS PADS AND ENDCAPS

• INSTALL THE RUBBER TREAD STRIP INTO THE UPPER CROSS BAR CHANNEL BY PUSHING IT INTO THE T-SLOT WITH THE PALM OF YOUR HAND. NOTE: SOME TRIMMING OF THE RUBBER TREAD STRIP MIGHT BE NECESSARY. USING WINDEX (GLASS CLEANER) AS A LUBRICANT HELPS WITH INSTALLATION

• INSTALL THE END CAPS INTO THE ENDS OF THE CROSS BARS.

CHECK ALL FASTENERS INSTALLED IN PREVIOUS STEPS TO ENSURE THEY ARE PROPERLY TIGHTENED

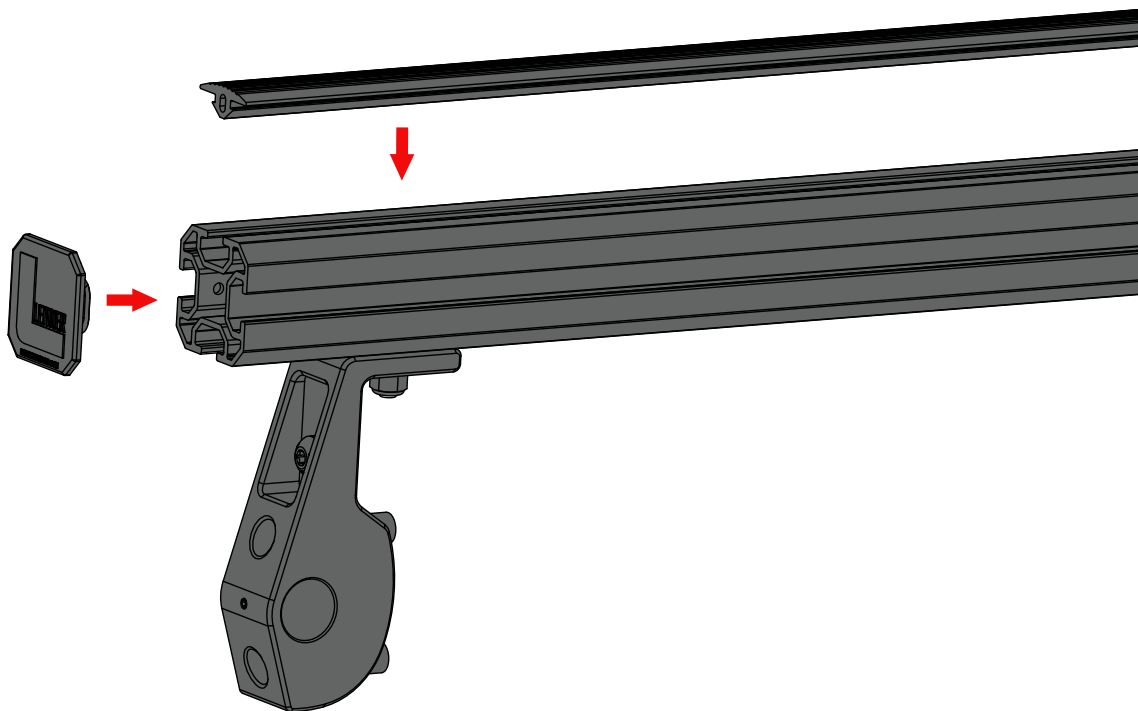

FINISHED: ADMIRE YOUR HANDY WORK

-YOU'RE ALL DONE! THE FINISHED ASSEMBLY SHOULD LOOK LIKE THIS DEPENDING ON HOW MANY LOAD BARS YOU PURCHASED.



USE GUIDELINES

WHEN USING LEITNER DESIGNS CARRIERS AND ACCESSORIES, THE USER MUST UNDERSTAND THE PRECAUTIONS. THE POINTS LISTED BELOW WILL ASSIST YOU IN USING THE RACK SYSTEM AND WILL ENCOURAGE SAFETY.

-FOR QUALITY FITS AND SAFETY, USE ONLY THE RECOMMENDED RACK OR ACCESSORIES. DO NOT ASSUME A RACK WILL FIT, ALWAYS CHECK THE CURRENT FIT GUIDE WHEN OBTAINING A NEW VEHICLE.

-THE MAXIMUM LOAD IS NOT TO BE EXCEEDED. (150# OFF ROAD – 300# ON ROAD). HOWEVER, **THIS LIMIT IS ALWAYS SUBORDINATE TO THE MAXIMUM LOAD RECOMMENDED BY THE MANUFACTURER OF THE VEHICLE ITSELF.** IT IS ALWAYS THE LOWER MAXIMUM RECOMMENDED LOAD THAT APPLIES. MAX TRUCK LOAD = LOAD CARRIER WEIGHT + ANY FITTED CARRIER ACCESSORIES + THE WEIGHT OF THE LOAD ITSELF.

-HIGH SPEED OFF ROAD DRIVING EVEN WITH A LIGHT LOAD CAN CAUSE DAMAGE TO THE RACK, ACCESSORIES AND VEHICLE BODY. DAMAGE CAUSED BY HIGH SPEED DRIVING AND ABUSE IS NOT COVERED UNDER WARRANTY.

-MAKE SURE ALL KNOBS, BOLTS, SCREWS, STRAPS, AND LOCKS ARE FIRMLY ATTACHED, TIGHTENED AND LOCKED BEFORE EVERY TRIP. KNOBS, BOLTS, SCREWS, STRAPS AND LOCKS MUST BE PERIODICALLY INSPECTED FOR SIGNS OF WEAR, CORROSION, AND FATIGUE. CHECK YOUR LOAD AT STOPS DURING THE TRIP TO ENSURE CONTINUED FASTENING SECURITY.

-CHECK LOCAL AND STATE LAWS GOVERNING PROJECTION OF OBJECTS BEYOND THE PERIMETER OF A VEHICLE. BE AWARE OF THE WIDTH AND HEIGHT OF YOUR CARGO SINCE LOW CLEARANCE BRANCHES, BRIDGES, AND PARKING GARAGES CAN AFFECT THE LOAD. ALL CARGO WILL AFFECT THE VEHICLE'S DRIVING BEHAVIOR. NEVER DRIVE WITH ANY LOCK, KNOB OR RACK IN AN OPEN OR UNLOCKED POSITION. ALL LONG LOADS SUCH AS, BUT NOT LIMITED TO, SAILBOARDS, SURFBOARDS, KAYAKS, CANOES, AND LUMBER MUST BE TIED DOWN FRONT AND REAR TO THE BUMPERS OR TOW HOOKS OF THE VEHICLE.

-ALL LOCKS MUST BE TURNED AND MOVED PERIODICALLY TO ENSURE SMOOTH OPERATION. USE GRAPHITE OR DRY LUBRICANT TO HELP THIS. LEITNER DESIGNS LOCKS ARE DESIGNED TO DETER VANDALISM AND THEFT BUT SHOULD NOT BE CONSIDERED THEFT PROOF. REMOVE VALUABLE GEAR IF YOUR VEHICLE IS UNATTENDED FOR AN EXTENDED PERIOD. PLACE AT LEAST ONE KEY IN THE GLOVE COMPARTMENT.

-FOR SAFETY TO YOUR VEHICLE AND RACK SYSTEM, OBEY ALL POSTED SPEED LIMITS AND TRAFFIC CAUTIONS. ADAPT YOUR SPEED TO THE CONDITIONS OF THE ROAD AND THE LOAD BEING CARRIED.

-DO NOT USE LEITNER DESIGNS LOAD CARRIERS AND ACCESSORIES FOR PURPOSES OTHER THAN THOSE FOR WHICH THEY WERE DESIGNED. DO NOT EXCEED THEIR CARRYING CAPACITY. FAILURE TO FOLLOW THESE GUIDELINES OR THE PRODUCT'S INSTRUCTIONS WILL VOID THE WARRANTY.

WARRANTY

LEITNER DESIGNS WARRANTS PRODUCT TO BE FREE FROM DEFECTS IN MATERIAL AND WORKMANSHIP, FOR TERMS SPECIFIED BELOW, PROVIDED THERE HAS BEEN NORMAL USE AND PROPER MAINTENANCE. ALL REMEDIES UNDER THIS WARRANTY ARE LIMITED TO THE REPAIR OR REPLACEMENT OF ANY ITEM FOUND BY THE FACTORY TO BE DEFECTIVE WITHIN THE TIME PERIOD SPECIFIED. IF YOU HAVE A WARRANTY CLAIM, FIRST YOU MUST CALL OUR FACTORY AT THE NUMBER BELOW FOR INSTRUCTIONS. YOU MUST RETAIN PROOF OF PURCHASE AND SUBMIT A COPY WITH ANY ITEMS RETURNED FOR WARRANTY WORK. UPON COMPLETION OF WARRANTY WORK, IF ANY, WE WILL RETURN THE REPAIRED OR REPLACED ITEM OR ITEMS TO YOU FREIGHT PREPAID. DAMAGE TO OUR PRODUCTS CAUSED BY ACCIDENTS, FIRE, VANDALISM, NEGLIGENCE, MIS-INSTALLATION, MISUSE, ACTS OF GOD, OR BY DEFECTIVE PARTS NOT MANUFACTURED BY US, IS NOT COVERED UNDER THIS WARRANTY.

THE WARRANTY TIME PERIOD IS AS FOLLOWS: (2) TWO YEARS FROM DATE OF PURCHASE.

HIGH SPEED OFF ROAD DRIVING EVEN WITH A LIGHT LOAD CAN CAUSE DAMAGE TO THE RACK, ACCESSORIES AND VEHICLE BODY. DAMAGE CAUSED BY HIGH SPEED OFF ROAD DRIVING AND ABUSE IS NOT COVERED UNDER WARRANTY.

ANY IMPLIED WARRANTIES OF MERCHANTABILITY AND/OR FITNESS FOR A PARTICULAR PURPOSE CREATED HEREBY ARE LIMITED IN DURATION TO THE SAME DURATION AND SCOPE AS THE EXPRESS WRITTEN WARRANTY. OUR COMPANY SHALL NOT BE LIABLE FOR ANY INCIDENTAL OR CONSEQUENTIAL DAMAGE.

SOME STATES DO NOT ALLOW LIMITATIONS ON HOW LONG AN IMPLIED WARRANTY LASTS, OR THE EXCLUSION OR LIMITATION OF INCIDENTAL OR CONSEQUENTIAL DAMAGES, SO THE ABOVE LIMITATIONS OR EXCLUSIONS MAY NOT APPLY TO YOU. THIS WARRANTY GIVES YOU SPECIFIC LEGAL RIGHTS, AND YOU MAY ALSO HAVE OTHER RIGHTS THAT VARY FROM STATE TO STATE.

FOR WARRANTY ISSUES WITH THIS PRODUCT PLEASE CALL LEITNER DESIGNS CUSTOMER SERVICE **949-395-3049** OR EMAIL US AT **SALES@LEITNERDESIGNS.COM**