

HARDWARE USER MANUAL



- **RPG5-2812-SFP8-10GSFP4**
- **RPG5-2812-SFP8-10GSFP4-T**

This document contains information, which is protected by copyright. Reproduction, adaptation or translation without prior permission is prohibited, except as allowed under the copyright laws.

Disclaimer

Leonton Technologies, Co. Ltd. provides this manual without warranty of any kind, expressed or implied, including but not limited to the implied warranties of merchantability and fitness for a particular purpose. Leonton Technologies, Co. Ltd. may make improvements and/or changes to the product and/or specifications of the product described in this manual, without prior notice. Leonton Technologies, Co. Ltd. will not be liable for any technical inaccuracies or typographical errors found in this guide. Changes are periodically made to the information contained herein and will be incorporated into later versions of the manual. The information contained is subject to change without prior notice.

FCC Notice

This equipment has been tested and found to comply with the limits for a Class-A digital device, pursuant to Part 15 of the FCC rules. These limits are designed to provide reasonable protection against harmful interference in a residential installation. This equipment generates, uses, and can radiate radio frequency energy. It may cause harmful interference to radio communications if the equipment is not installed and used in accordance with the instructions. However, there is no guarantee that interference will not occur in a particular installation. If this equipment does cause harmful interference to radio or television reception, which can be determined by turning the equipment off and on, the user is encouraged to try to correct the interference by one or more of the following measures:

- Reorient or relocate the receiving antenna.
- Increase the separation between the equipment and receiver.
- Connect the equipment into an outlet on a circuit different from that to which the receiver is connected.
- Consult the dealer or an experienced radio/TV technician for help.

Caution: Any changes or modifications not expressly approved by the grantee of this device could void the user's authority to operate the equipment.

Déclaration FCC

Cet équipement a été testé et reconnu conforme aux limites de la classe A pour les équipements numériques, conformément à la section 15 des Réglementations FCC. Ces limites sont conçues pour fournir une protection raisonnable contre toutes interférences nuisibles dans un milieu résidentiel. Cet équipement génère, utilise, et peut émettre de l'énergie de fréquence radio et, s'il n'est pas installé et utilisé conformément au manuel d'instruction, peut perturber la réception radio. Cependant, il n'est pas garanti que l'équipement ne produira aucune interférence dans une installation particulière. Si cet équipement cause des interférences nuisibles à la réception radio ou télévisée, qui peuvent être déterminées en l'éteignant et le rallumant, l'utilisateur est encouragé à essayer de remédier au problème en prenant les mesures suivantes:

- Réorienter ou déplacer l'antenne réceptrice.
- Augmenter la distance entre l'équipement et le récepteur.
- Connecter l'équipement à une prise secteur sur un circuit différent de celui utilisé par le récepteur.
- Consulter le négociant ou un technicien radio/TV expérimenté.

Attention: Tout changement ou modification non expressément approuvé par le concessionnaire de cet appareil pourrait annuler l'autorité de l'utilisateur à utiliser l'équipement.

CE Mark Warning

This is a Class-A product. In a domestic environment this product may cause radio interference in which case the user may be required to take adequate measures.

CE Mark Avertissement

Ceci est un produit de classe A. Dans un environnement domestique, ce produit peut être utilisé en présence d'interférences radio.

This document is the current official release manual. Please check our website (www.leonton.com) for any updated manual or contact us by e-mail (sales@leonton.com).

CONTENT

OVERVIEW	5
Key Features	5
Package Contents	6
Safety Precaution	6
HARDWARE DESCRIPTION	7
Physical Dimensions	7
Front Panel	8
LED Indicators	9
Reset Button	11
Ethernet Ports	12
Cabling	13
Wiring the Power Inputs	15
Relay Contact and Digital Input	16
Grounding Note	16
MOUNTING INSTALLATION	18
Rack Mounting	18
HARDWARE INSTALLATION	19
Installation Steps	19
TROUBLE SHOOTING	21

OVERVIEW

This series is rated IP30 and Rack-Mounting installation. Each unit of this Industrial Managed Gigabit Ethernet switch series has 16*port 10/100/1000BASE-T Gigabit Ethernet with IEEE 802.3at compliant PoE(30W/port), 4*port 1G/2.5G/10GbE SFP+ and 8*port 100/1000BASE-X SFP slots, suitable for applications that require high bandwidth and long distance communication.

In order to prevent unregulated voltage, this series provides high EFT and ESD protection. This also allows it to function in harsh environments, as well as support power redundancy with a dual power input design with reverse polarity protection. The built-in relay warning function alerts users about occurring power failures.

With one model having an operating temperature of -10 to 65°C, and another with a wide operating temperature of -40 to 75°C, this series is designed to meet any needs in industrial automation, outdoor application and harsh environments.

Key Features

Interface & Performance

- All Copper ports support auto MDI/MDI-X function
- Embedded 16*port 10/100/1000 BASE-T Gigabit Ethernet with IEEE 802.3at compliant PoE(30W/port), 4*port 1G/2.5G/10GbE SFP+ and 8*port 100/1000BASE-X SFP slots
- Store-and-forward switching architecture
- 32K MAC Address Table
- Supports 10Kbytes Jumbo Frame
- 32Mbits memory buffer

Power Input

- Dual 48-55VDC redundant power inputs with 1*8-contact terminal block
- Max. current 10.9A
- Max. PoE output: 480W
- Relay Contact: 24 VDC, 1A resistive
- The power input specification is complied with the requirements of SELV (Safety Extra Low Voltage), and the power supply should be complied with UL 61010-1 & UL 61010-2-201

Certification

- CE/FCC
- UL 61010-1
- UL 61010-2-201
- ISA12.12.01
- IEC-61850-3 (Pending)

Operating Temperature

- Standard operating temperature model: -10°C ~ 65°C
- Extended operating temperature model (-T): -40°C ~ 75°C

Case/Installation

- IP30 protection
- Rack-mount design
- Installation in a pollution degree 2 industrial environment

- Standalone Installation

Package Contents

- 1 – RPG5-2812-SFP8-10GSFP4(-T) 4.00 kg (8.82 lb), Shipping weight:5.00 kg (11.02 lb)
- 2 – Rack-mounting brackets and screws
- 1 – Quick installation guide
- 1 – RJ45 to DB9 Serial Console cable

Safety Precaution

Attention

If the DC voltage is supplied by an external circuit, please use a protection device on the power supply input. Supply by UL Listed industrial use power. The industrial Ethernet switch's hardware specs, ports, cabling information, and wiring installation will be described within this user manual.

Attention

Si la tension CC est fournie par un circuit externe, veuillez utiliser un dispositif de protection sur l'entrée d'alimentation. Fourniture par courant industriel homologué UL. Les spécifications matérielles, les ports, les informations de câblage et l'installation du câblage du convertisseur de média industriel seront décrits dans ce manuel d'utilisation.

Warning Labels

The caution label means that you should check the certain information on user manual when working with the device. (Shown in *Figure 1.1*)

Étiquettes d'avertissement

L'étiquette d'avertissement signifie que vous devez vérifier certaines informations sur le manuel d'utilisation lorsque vous travaillez avec l'appareil. (Montré dans la *Figure 1.2*)



Figure 1.1 - Caution Label
Figure 1.1 - Étiquette de mise en garde



Figure 1.2 - Hot Surface Warning Label
Figure 1.2 - Étiquette d'avertissement de surface chaude

HARDWARE DESCRIPTION

Physical Dimensions

Figure 2.1, below, shows the physical dimensions of RPG5-2812-SFP8-10GSFP4 series

(W x H x D) is 440mm x 44mm x 215mm

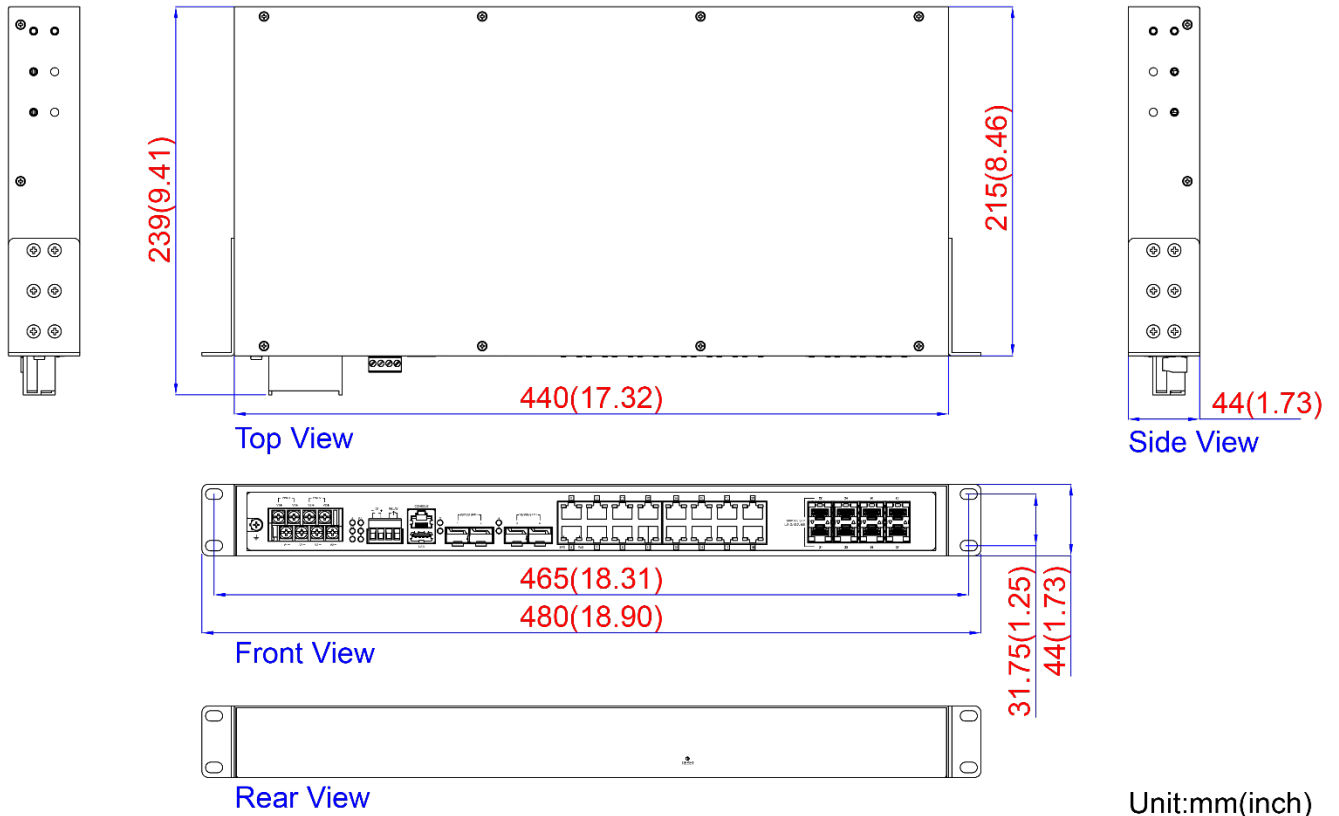

Figure 2.1: Physical Dimensions

Front Panel

The front panel of the RPG5-2812-SFP8-10GSFP4 series industrial Rack-mount managed Gigabit Ethernet PoE+ switch is shown below in Figure 2.2.

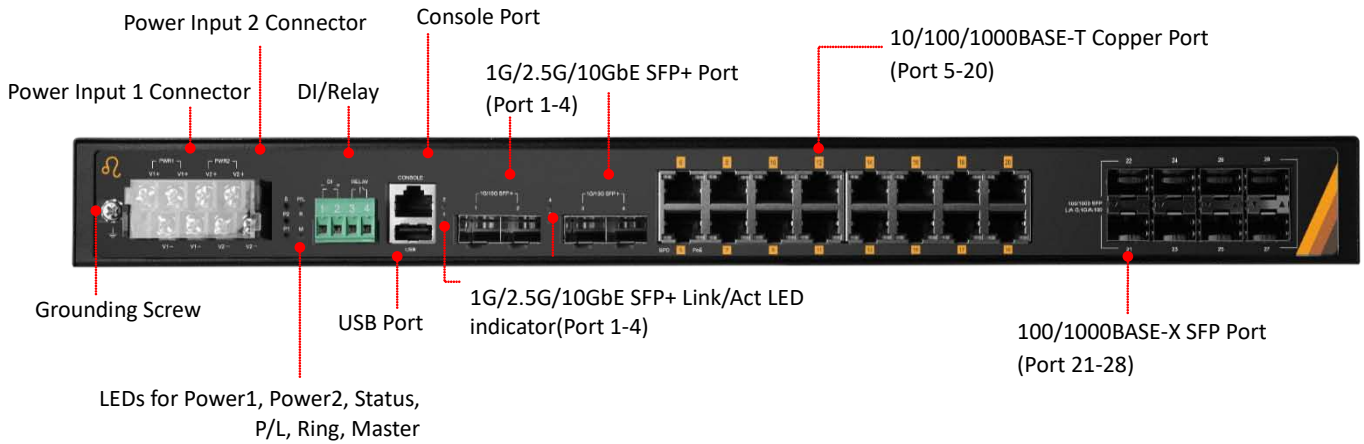

Figure 2.2: The Front Panel

Rear Panel

Figure 2.3, below, shows the rear panel of the RPG5-2812-SFP8-10GSFP4 series switches that is equipped with Reset Button.



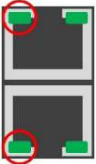

Figure 2.3: Rear Panel View

LED Indicators

There are LED light indicators located on the front panel of the industrial switch that display the power status and network status. Each LED indicator has a different color and has its own specific meaning, see below in Table 2.1.

Table 2.1: LED Indicators

LED	Color	Description	
P1	Green	On	Power input 1 is active
		Off	Power input 1 is inactive
P2	Green	On	Power input 2 is active
		Off	Power input 2 is inactive
STATUS	Green	On	No event happened
		Flashing	Press the reset button less than 4s (Reset device)
	Red	On	Event happened
		Flashing	1. System booting 2. Press the reset button more than 8s (Backup configuration to USB)
	Green & Red	Flashing	Press the reset button more than 4s~8s (Reset to default)
MASTER	Green	On	ERPS Owner Mode (Ring Master) is ready
		Off	ERPS Owner Mode is not active
RING	Green	On	ERPS Ring Network is active and works well
		Flashing	ERPS Ring works abnormally or misconfigure
		Off	ERPS Ring Network is not active
PoE Load	-	Off	The current overall PoE output power divided by power budget is $\leq 50\%$
	Green	On	The current overall PoE output power divided by power budget is $51\% \sim 70\%$
	Red	On	The current overall PoE output power divided by power budget is $71\% \sim 90\%$
	Red	Flashing (1 time/s)	The current overall PoE output power divided by power budget is $91\% \sim 100\%$
10G SFP L/A (Port 1-4 SFP)	Green	On	Connected to network, 10Gbps
		Flashing	Networking is active
		Off	Not connected to network
	Amber	On	Connected to network, 2.5G/1Gbps
		Flashing	Networking is active
		Off	Not connected to network

GE - SPD (Port 5-20 Copper)	<p>Green</p> 	On	Connected to network, 1000Mbps
		Flashing	Networking is active
		Off	Not connected to network
	<p>Amber</p> 	On	Connected to network, 10/100Mbps
		Flashing	Networking is active
		Off	Not connected to network
PoE Port (Port 5-20 Copper)	<p>Green</p> 	On	Supplying PoE at (30w)/af power to the powered-device
		Off	Not connected to a Powered Device
1G SFP L/A (Port 21-28 SFP)	Green	On	Connected to network, 1Gbps
		Flashing	Networking is active
		Off	Not connected to network
	Amber	On	Connected to network, 100Mbps
		Flashing	Networking is active
		Off	Not connected to network

Reset Button

There is a “reset” button located on the top panel of the industrial Ethernet switch that helps users to reboot, restore default, or save running configurations by pressing the button for different seconds. Please refer to Table 2.2 for the timing and function.

Seconds	Function
$0 < t(\text{press time}) < 4$ seconds	Reboot: Status LED is flashing with green color.
$4 < t(\text{press time}) < 8$ seconds	Reset to factory default: Status LED is flashing with green and red color.
$8 < t(\text{press time})$	Backup configuration to USB: Status LED is flashing with red color.

Table 2.2 - Reset Button Functions

Ethernet Ports

RJ-45 Ports (Auto MDI/MDIX)

The RJ-45 ports are auto-sensing for 10BASE-T, 100BASE-TX or 1000BASE-T devices connections. Auto MDI/MDIX means that the switch can connect to another switch or workstation without changing the straight-through or crossover cabling. See the figures as below for straight-through and crossover cabling schematics.

1 2 3 4 5 6 7 8

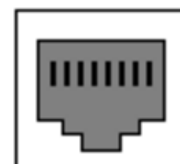

RJ-45 Female

10/100BASE-T(X) RJ-45 Pin Assignments (Table 2.3)

Crossover Cable		Straight Through Cable	
Pin Number / Signal	Pin Number / Signal	Pin Number / Signal	Pin Number / Signal
1 / RX+	3 / TX+	1 / RX+	1 / TX+
2 / RX-	6 / TX-	2 / RX-	2 / TX-
3 / TX+	1 / RX+	3 / TX+	3 / RX+
6 / TX-	2 / RX-	6 / TX-	6 / RX-

Table 2.3

1000BASE-T RJ-45 Pin Assignments (Table 2.4)

Crossover Cable		Straight Through Cable	
Pin Number / Signal	Pin Number / Signal	Pin Number / Signal	Pin Number / Signal
1 / TP0+	3 / TP1+	1 / TP0+	1 / TP1+
2 / TP0-	6 / TP1-	2 / TP0-	2 / TP1-
3 / TP1+	1 / TP0+	3 / TP1+	3 / TP0+
4 / TP2+	7 / TP3+	4 / TP2+	4 / TP3+
5 / TP2-	8 / TP3-	5 / TP2-	5 / TP3-
6 / TP1-	2 / TP0-	6 / TP1-	6 / TP0-
7 / TP3+	4 / TP2+	7 / TP3+	7 / TP2+
8 / TP3-	5 / TP2-	8 / TP3-	8 / TP2-

Table 2.4

Note: “+” and “-” signs represent the polarity of the wires that make up each wire pair.

Cabling

Use the four twisted-pair, category 5e, or the above cabling for RJ-45 port connections. The cable between the switch and the link partner (switch, hub, workstation, etc.) must be less than 100 meters (328 ft.) long.

The small form-factor pluggable (SFP) is a compact optical transceiver used in optical communications for both telecommunication and data communication applications.



Caution: Please employ optional optical transceiver (SFP/Fixed Fiber) that complies with IEC 60825-1 and classified as Class 1 laser product.



Attention: Veuillez utiliser un émetteur-récepteur optique (SFP) conforme à la norme CEI 60825-1 et classé comme produit laser de classe 1.

To connect the transceiver and LC cable, please follow below steps:

Step 1 Insert the SFP transceiver module into the SFP slot as shown below in Figure 2.4. Notice that the triangle mark is at the bottom of the SFP slot. Figure 2.5 shows SFP transceiver module was inserted.

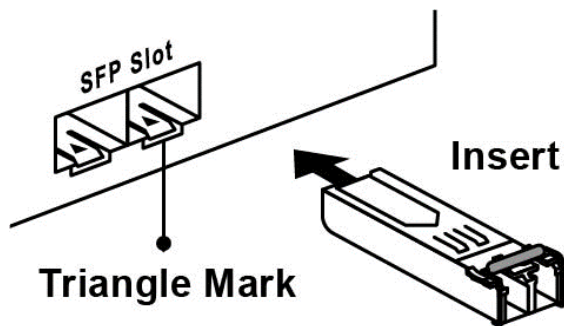

Figure 2.4: Transceiver to the SFP Module

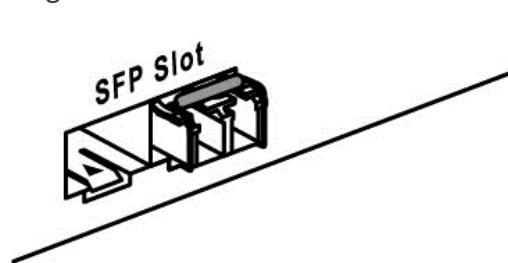

Figure 2.5: Transceiver Inserted

Step 2 Insert the fiber cable of the LC connector into the transceiver as shown below in Figure 2.6.

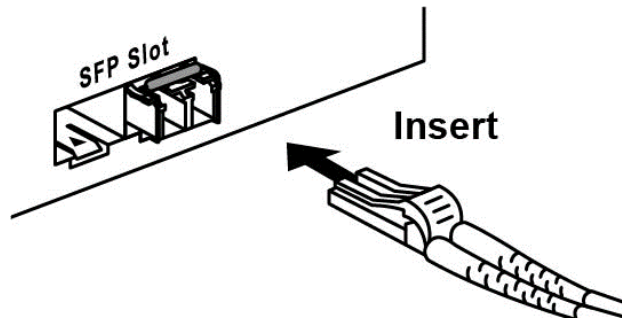

Figure 2.6: LC Connector to the Transceiver

To remove the LC connector from the transceiver, please follow the steps shown below:

Step 1 Press the upper side of the LC connector from the transceiver and pull it out to release as shown below in Figure 2.7

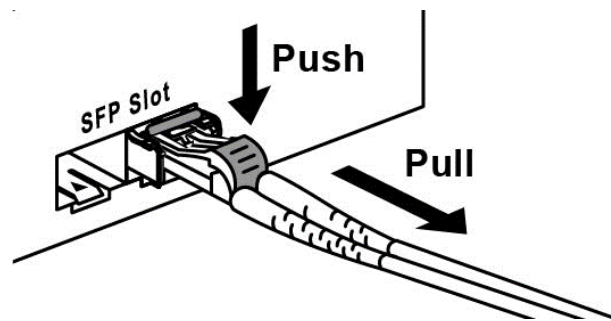

Figure 2.7: Remove LC Connector

Step 2 Push down the metal clasp and pull the transceiver out by the plastic part as shown below in Figure 2.8

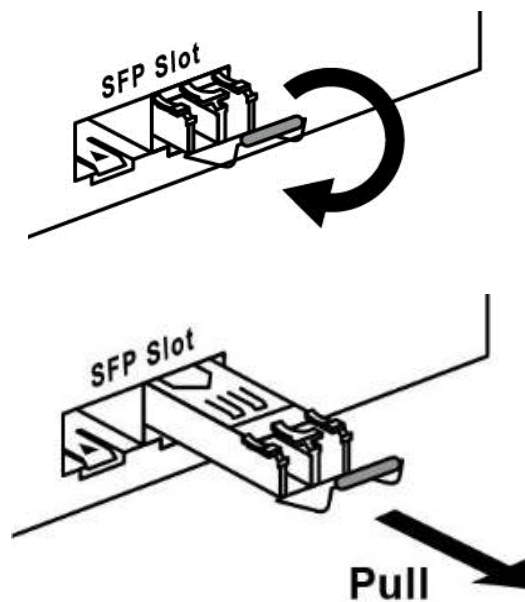

Figure 2.8: Pull Out from the SFP Module

Wiring the Power Inputs



Caution: Please follow the below steps to insert the power wire.



Attention: Veuillez suivre les étapes ci-dessous pour insérer le câble d'alimentation.

Step 1. Insert the positive and negative wires into the PWR1 (V1+, V1-) and PWR2 (V2+, V2-) contacts on the connector as shown below in Figure 2.9.

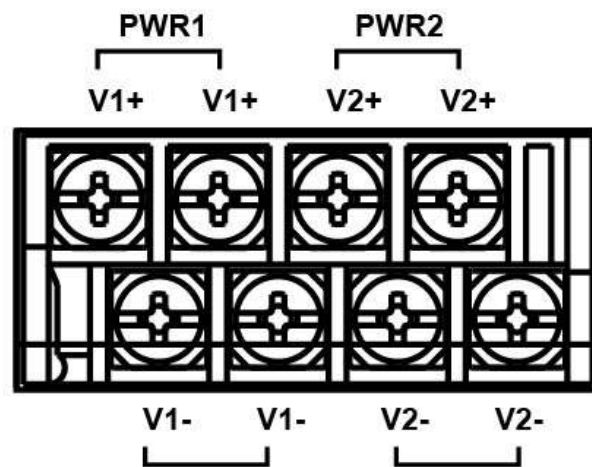

Figure 2.9: Power Input Connector



Caution: Only use copper conductors, 125°C, tighten to 7 in-lbs (0.79 Nm). The wire gauge for the terminal block should range between 18~20 AWG.



Attention: Utilisez uniquement des conducteurs en cuivre, 125 ° C, serrer à 7 in-lbs (0,79 Nm). Le calibre des fils du bornier doit être compris entre 18 et 20 AWG.

Relay Contact and Digital Input

Relay Contact

The relay contact is in one of the terminal block connectors as the picture shows below in Figure 2.10. By inserting the wires, it will detect the fault status including power failure or DI Event, and port link failure (managed industrial switch only) and form a normally open circuit.

Digital Input (DI)

The digital input is used for monitoring external events via an external voltage source. When the voltage level on digital input pins changes from high voltage to low voltage, the DI function will be triggered. Table 5 is shown a detail specification of the digital input.

Specification		Description
Level 0 (Low)	-30~8VDC	Will trigger DI function (active trigger states)
Level 1 (High)	10~30VDC	Normal Status (inactive trigger states)
Nominal input voltage	24VDC	
Max. input voltage	30VDC	
Nominal input current	5mA (typical)	
Max. input current	8mA	

Table 5: Specification of DI

An application example for the relay alarm contact and DI is shown below in Figure 2.10.

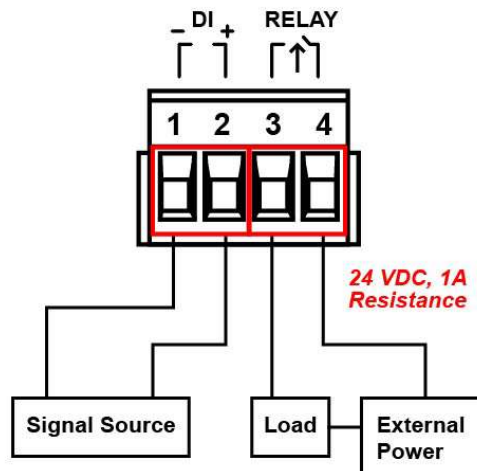

Figure 2.10: Wiring the DI and Relay Alarm Contact



Caution: The wire gauge for the terminal block should range between 12 ~ 24 AWG.

If only using one power source, jumper Pin 1 to Pin 5 and Pin 2 to Pin 6 to eliminate power fault alarm.



Attention: Le calibre des fils du bornier doit être compris entre 12 et 24 AWG.

Si vous n'utilisez qu'une seule source d'alimentation, jumelez les broches 1 à 5 et les broches 2 à 6 pour éliminer l'alarme de panne de courant.

Grounding Note

Grounding and wire routing help limit the effects of noise due to electromagnetic interference (EMI). Run the ground connection from the ground screw to the grounding surface prior to connecting devices. The grounding screw symbol is shown below in Figure 2.11.



Figure 2.11: Grounding screw symbol



Caution: Using a shielded cable achieves better electromagnetic compatibility.



Attention: L'utilisation d'un câble blindé permet une meilleure compatibilité électromagnétique.

MOUNTING INSTALLATION

Rack Mounting

This switch can be mounted in a standard 19-inch rack with rack-mount kits. Please follow the instruction shown below in Figure 3.1 to install rack-mounting switch. Locate one plate to align with the holes on one side of the switch and secure it with the plate screws and then attach the remaining plate to the other side of the switch.

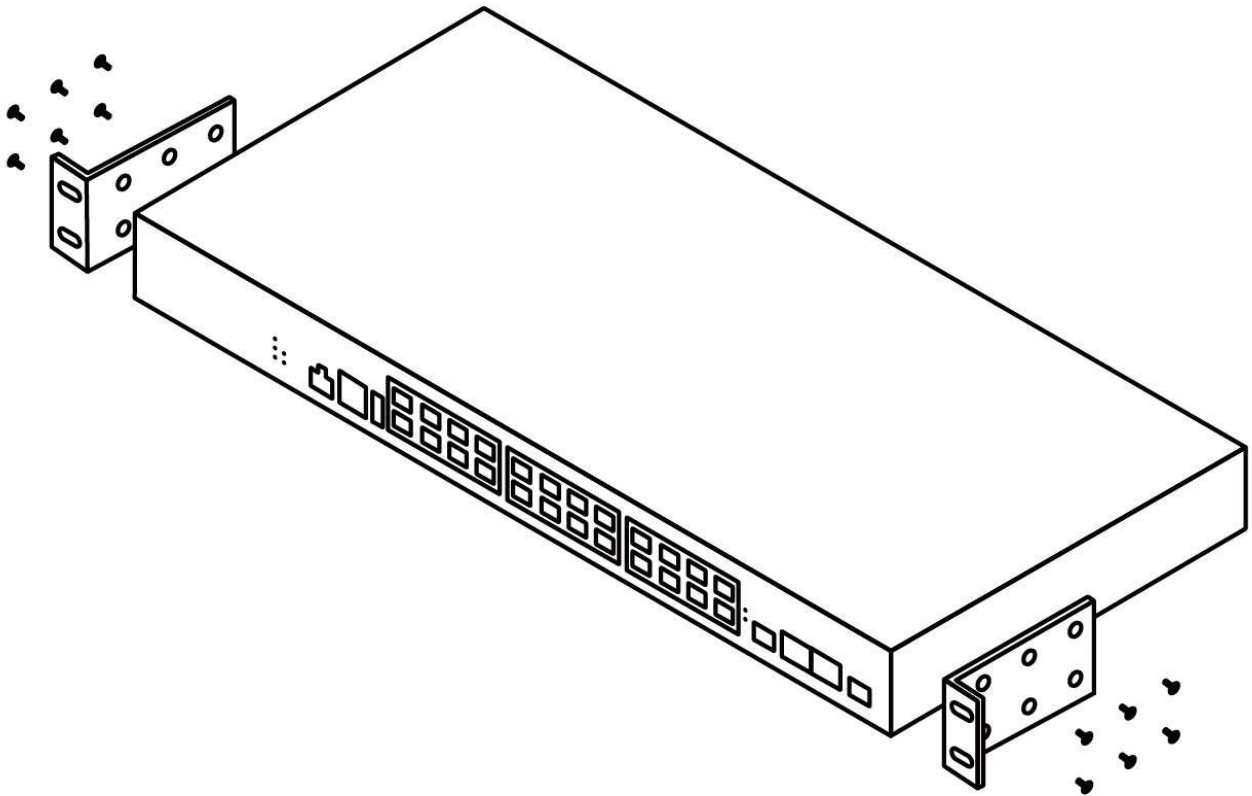

Figure 3.1: The Top View of the Switch and Rack Mounting Bracket

HARDWARE INSTALLATION

Installation Steps

This section will explain how to install RPG5-2812-SFP8-10GSFP4 series.

Installation Steps

- Step 1. Unpack the industrial switch from the original packing box.
- Step 2. If the rack-mount bracket is not screwed on the industrial switch, please refer to the **Rack Mounting** section for installation.
- Step 3. Power on the industrial switch and then the power LED light will turn on.
 - If you need help on how to wire power, please refer to the **Wiring the Power Inputs** section.
 - Please refer to the **LED Indicators** section for LED light indication.
- Step 4. Prepare the twisted-pair, straight-through category 5 cable for Ethernet connection.
- Step 5. Insert one side of the RJ-45 cable into switch's Ethernet port and on the other side into the networking device's Ethernet port, e.g. switch PC or server. The Ethernet port's (RJ-45) LED on the industrial switch will turn on when the cable is connected to the networking device.
 - Please refer to the LED Indicators section for LED light indication.
- Step 6. Insert one side of the SFP cable into switch's SFP port and on the other side into the networking device's SFP port, e.g. switch or server. The SFP port's LED on the industrial switch will turn on when the cable is connected to the networking device.
 - Please refer to the LED Indicators section for LED light indication.
- Step 7. When all connections are set and the LED lights all show normal, the installation is complete.



Caution: If the equipment is used in a manner not specified by the manufacturer, the protection provided by the equipment may be impaired.



Attention: Si l'équipement est utilisé d'une manière non spécifiée par le fabricant, la protection fournie par l'équipement peut être altérée.



Caution: The installation that the safety to any system incorporating the equipment is the responsibility of the assembler of the system.



Attention: L'installation que la sécurité de tout système intégrant l'équipement est de la responsabilité de l'assembleur du système.



Caution: This is an OPEN TYPE module and should be installed in a final safety enclosure characteristic.



Attention: Il s'agit d'un module de TYPE OUVERT et doit être installé dans une caractéristique finale d'enceinte de sécurité.



Caution: This device is intended for use indoor and at altitudes up to 2000 meters.



Attention: Cet appareil est destiné à être utilisé en intérieur et à des altitudes allant jusqu'à 2000 mètres.



Caution: Ambient Relative Humidity should be within the range of 5 and 95% (non-condensing).



Attention: L'humidité relative ambiante doit être comprise entre 5 et 95% (sans condensation).

TROUBLE SHOOTING

- Verify you have the right power cord or adapter. Never use a power supply or adapter with a non-compliant DC output voltage or it will burn the equipment.
- Select the proper UTP or STP cable in order to construct the network. Use an unshielded twisted-pair (UTP) or shield twisted-pair (STP) cable for RJ-45 connections: 100Ω Category 5e for 10M/100/1000Mbps. Also be sure that the length of any twisted-pair connection does not exceed 100 meters (328 feet).
- Diagnosing LED Indicators: To assist in identifying problems, the switch can be easily monitored with the LED indicators which help to identify if any problems exist.
 - ◆ Please refer to the LED Indicators section for LED light indication.
- If the power indicator LED does not turn on when the power cord is plugged in, the user may have a problem with the power cord. Check for loose power connections, power losses or surges at the power outlet.
 - ◆ Please contact Leonton for technical support service, if the problem still cannot be resolved.
- If the industrial switch LED indicators are normal and the connected cables are correct but the packets still cannot transmit, please check the system's Ethernet devices' configuration or status.

For any repair or maintenance needs, please contact us.

LEONTON TECHNOLOGIES, CO., LTD
17F., No. 932, Zhongzheng Rd., Zhonghe Dist.,
New Taipei City, 235015,
Taiwan
TEL: +886 2 22183113
FAX: +886 2 22187391