



Cadillac SRX 2010-2012

Visit MetraOnline.com for more detailed information about the product and up-to-date vehicle specific applications

KIT FEATURES (See Interface Installation section for more features)

- Designed for most shallow mount aftermarket radios and Pioneer modular radios DMH-C2550NEX and DMH-C2500NEX.

Note: See manufacturer for current models.

- Retains factory control panel and display of climate functions and vehicle customization menus on the 107-GM5B OLED screen.
- Retains audio control on steering wheel and radio control buttons on the factory control panel.

KIT COMPONENTS

- A) Center dash panel • B) Top trim panel • C) Radio brackets • D) Pioneer display brackets • E) Pioneer chassis brackets
- F) Three panel clips (top panel) • G) Interface and wiring (not shown)

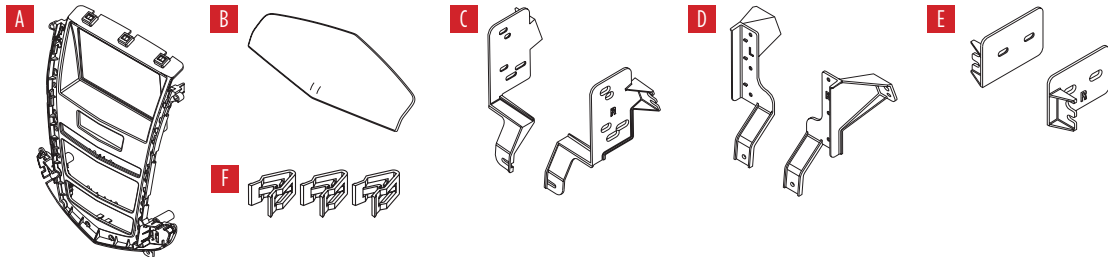

TABLE OF CONTENTS

| | |
|--|------|
| Dash Disassembly | 2-3 |
| Kit Preparation | 4-6 |
| Kit Assembly | |
| – Shallow DDIN radio provision | 7 |
| – Pioneer modular DDIN radio provision | 8 |
| Axxess Interface Installation | 9-19 |

WIRING & ANTENNA CONNECTIONS

Wire harness: Axxess interface included

Antenna adapter: Included

Steering wheel control interface: Included

RGB Extension Cable: Pioneer part # CD-RGB150E (not sold by Metra)

TOOLS REQUIRED

- Panel removal tool • Phillips screwdriver
- 9/32" Socket wrench • T-15 Torx screwdriver

ATTENTION: With the key out of the ignition, disconnect the negative battery terminal before installing this product. Ensure that all installation connections are secure before cycling the ignition to test this product.
NOTE: Refer also to the instructions included with the aftermarket radio.

DASH DISASSEMBLY

1. Using the panel removal tool, carefully unclip and remove the trim panels from both sides of the center console. (Figure A)
2. Remove (2) 9/32" screws located on both sides of the padded trim of the center console. Unclip and remove the padded trim. (Figure B)
3. Using the panel removal tool, gently unsnap and remove the u-shaped trim around the lower dash pocket. (Figure C)

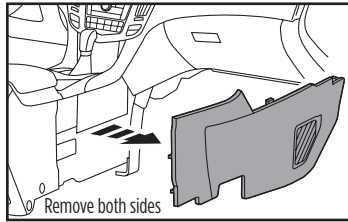

(Figure A)

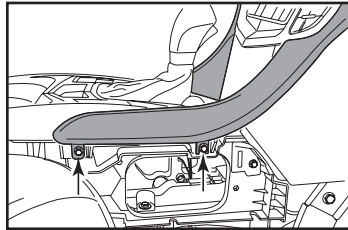

(Figure B)

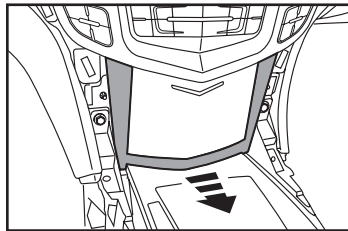

(Figure C)

4. Remove (2) 9/32" screws securing the lower portion of the control panel. (Figure D)
5. Pull the pocket from the top to allow the upper control panel to pass.

Continued on the next page

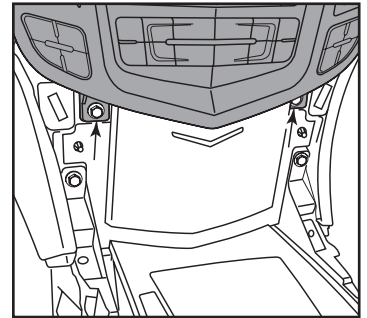

(Figure D)

DASH DISASSEMBLY (CONT.)

NAV Models

6. For NAV equipped models, motorize the screen up, unclip the left and right legs securing the trim over the top of the motorized display screen, then lift up to remove the trim. (Figure E)
7. Unplug the control panel and lift up enough to access the (2) 9/32" screws and 10mm nut. Plug the control panel back in and power the screen down to remove the control panel. (Figure F)
Note: If the airbag light is unplugged during this process be sure not to cycle the ignition.

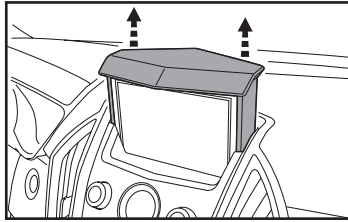

(Figure E)

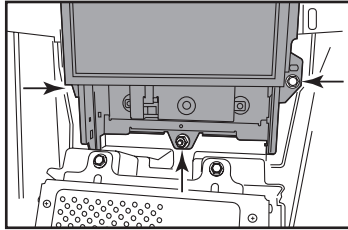

(Figure F)

Both NAV and Non-NAV

8. Using the panel removal tool, gently, unclip and remove the control panel. (Figure G)
9. Remove (4) 9/32" screws securing the radio chassis. Slide the chassis out, then unplug and remove the radio. (Figure H)

Continue to Kit Preparation

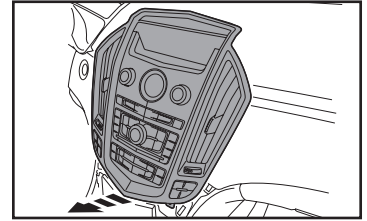

(Figure G)

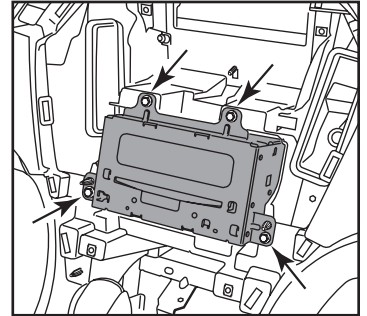

(Figure H)

KIT PREPARATION

From the factory control panel:

Non-NAV

1. Unsnap the top trim panel from the control panel. (above the screen) (Figure A)
2. Remove (4) Phillips screws and the factory screen. (Figure B)
3. Remove (6) Phillips screws to remove the factory screen bezel. (Figure C)

Continued on the next page

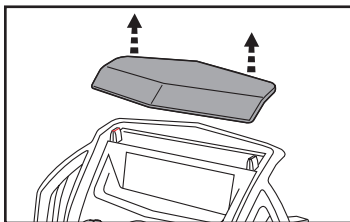

(Figure A)

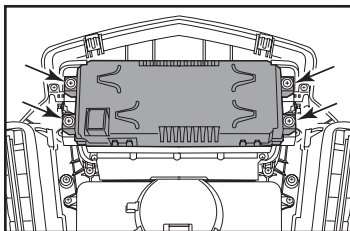

(Figure B)

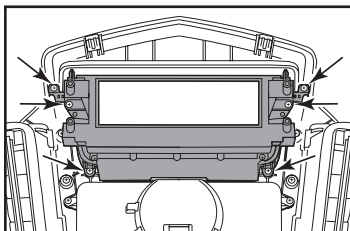

(Figure C)

From the factory control panel:

NAV models

1. Remove (4) Phillips screws to remove the factory screen bezel. (Figure A)

Continue to Step 4 on the next page

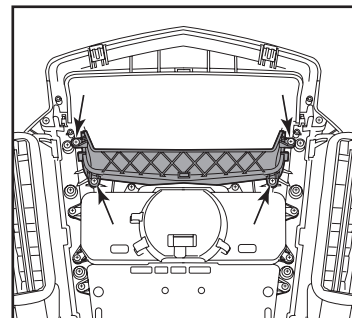

(Figure A)

KIT PREPARATION (CONT.)

From the factory control panel:

Both NAV and Non-NAV

4. Remove (6) Phillips screws securing the clock panel, unplug the connectors and remove the panel. (Figure D)
5. Remove (10) Phillips screws securing the control button panel, then unplug and remove the panel. (Figure E)
6. Remove (16) Phillips screws securing the inner housing. Unplug the lower climate controls, then remove the housing from the outer silver trim. (Figure F)

Continued on the next page

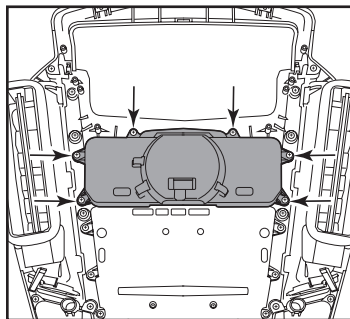

(Figure D)

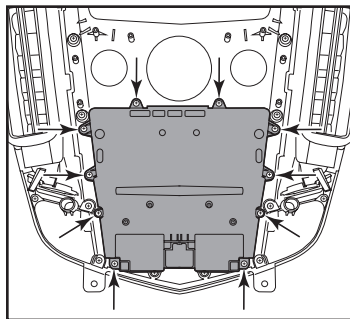

(Figure E)

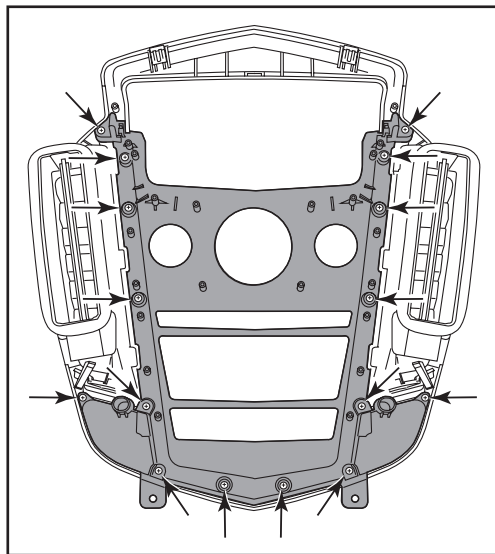

(Figure F)

KIT PREPARATION (CONT.)

Dash Panel Assembly

7. Secure the 107-GM5B dash panel using (16) factory screws. (Figure G)
8. Cut off the top (2) mounting legs from the main factory climate buttons. (Figure H)
9. Secure the main factory climate buttons using (8) factory screws. (Figure I)
10. Connect the lower climate controls.
Caution: Make sure the keyways line up or the connector can be forced in wrong.

Continue to Kit Assembly

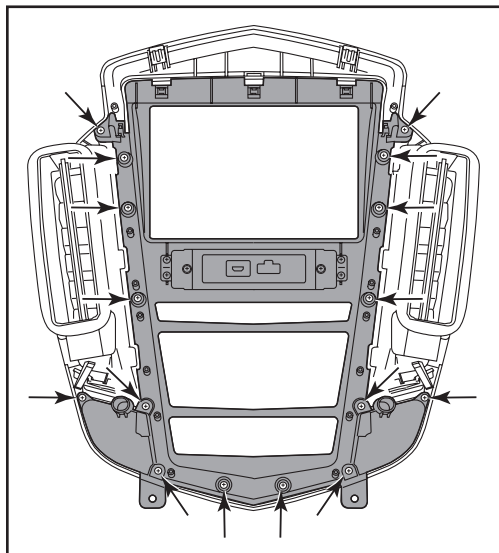

(Figure G)

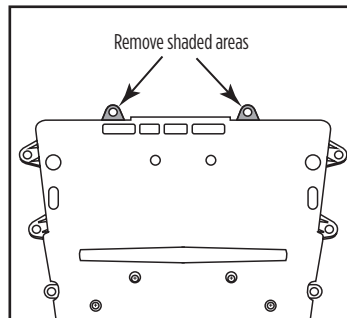

(Figure H)

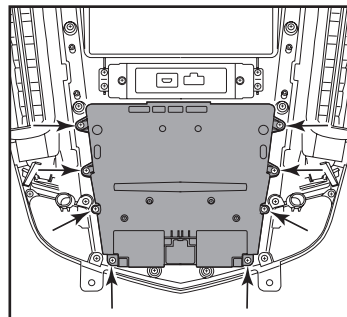

(Figure I)

KIT ASSEMBLY

ISO DDIN radio provision

1. Secure the **radio brackets** to the radio using (4) screws supplied with the radio. (Figure A)
2. Reconnect the negative battery terminal and prepare for Axxess interface installation.

Continue to Axxess Interface Installation

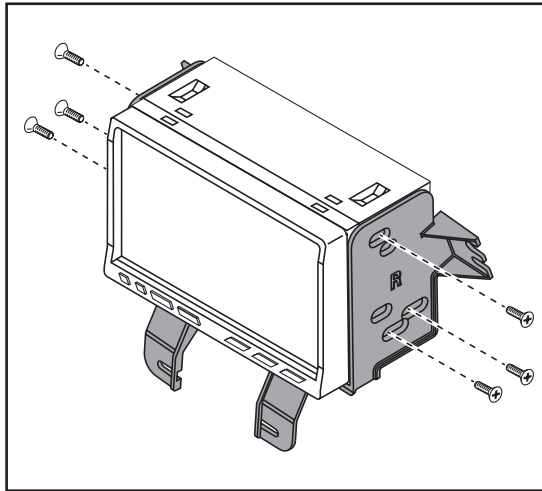

(Figure A)

KIT ASSEMBLY

Pioneer Modular DDIN radio provision

Note: For steps 1 and 2, reference the installation manual provided with the radio for which hardware to use. The display screen and radio chassis use two different types of screws.

1. Secure the display screen to the **Pioneer display brackets** using (6) screws supplied with the radio. (Figure A)
2. Connect the RGB extension cable to the display, then route the cable downward where the factory radio chassis was located. (Figure B)

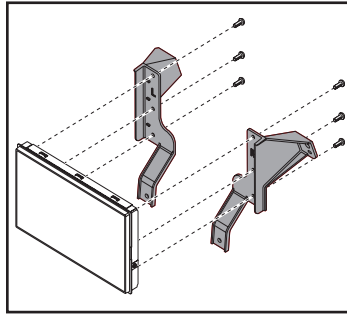

(Figure A)

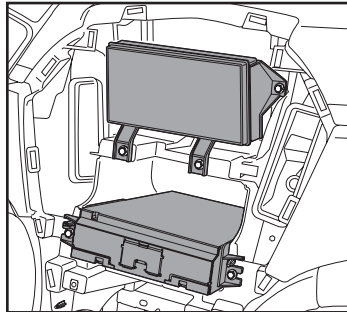

(Figure B)

3. Using the factory screws, secure the display screen assembly to the dash where the factory display was located. (Figure B)
4. Secure the **Pioneer chassis brackets** to the radio chassis using (4) screws supplied with the radio. (Figure C)

Continue to Axxess Interface Installation

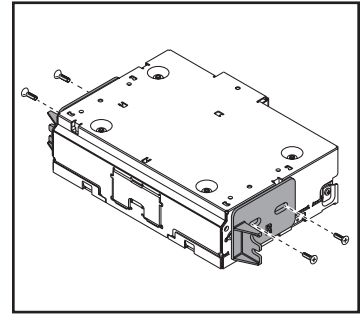

(Figure C)

AXXESS INTERFACE INSTALLATION

INTERFACE FEATURES

- Retains factory control panel and display of climate functions and vehicle customization menus on the 107-GM5B OLED screen.
- Provides accessory power (12-volt 10-amp)
- Maintains the Retained Accessory Power (R.A.P.) feature
- Retains factory backup camera
- Provides illumination
- Provides parking brake, reverse, and speed sense outputs
- Retains audio control on steering wheel and radio control buttons on the factory control panel
- Retains warning chimes
- Retains OnStar/OE Bluetooth
- Adjustable volume for chimes and OnStar
- Can be used in non-amplified, or amplified models
- Retains balance and fade
- USB Micro-B updatable

INTERFACE COMPONENTS

- Axxess interface
- 3"x2" OLED display
- Car side harness (LD-BX-GM8)
- Climate control T-harness (LD-SRXHVAC)
- Female 3.5mm jack (LD-SWC-F3.5)
- 16-pin harness with stripped leads (LD-2NAVAMPL)
- 4-pin to 4-pin resistor pad harness (LD-GMOS100RPAD)
- Backup cam harness (LD-BACKUPCAM-2)

TABLE OF CONTENTS

| | |
|---------------------------------------|-------|
| Connections..... | 10-11 |
| Programming..... | 12-13 |
| Steering wheel control settings | 14-18 |
| Final assembly | 19 |

TOOLS REQUIRED

- Crimping tool and connectors, or solder gun, solder, and heat shrink
- Tape
- Wire cutter
- Zip-ties

CONNECTIONS

For models without an amplifier:

From the 16-pin harness with stripped leads to the aftermarket radio, connect as indicated:

- **Red** wire to the accessory wire.
- **Orange/White** wire to the illumination wire. (if applicable)
- **Brown** wire to the mute wire. (if applicable)
Note: If the mute wire is not connected, the radio will turn off when OnStar is activated.
- **Gray** wire to the right front (+) speaker output.
- **Gray/Black** wire to the right front (-) speaker output.
- **White** wire to the left front (+) speaker output.
- **White/Black** wire to the left front (-) speaker output.

The following (3) wires are only for multimedia/navigation radios that require these wires.

- **Green/Purple** wire to the reverse wire.
- **Light Green** wire to the parking brake wire.

Tape off and disregard the following (5) wires, they will not be used in this application:

Blue/White, Purple, Purple/Black, Green, Green/Black

From the car side harness to the aftermarket radio connect as indicated:

- **Black** wire to the ground wire.
- **Yellow** wire to the battery wire.
- **Green** wire to the left rear (+) speaker output.
- **Green/Black** wire to the left rear (-) speaker output.
- **Purple** wire to the right rear (+) speaker output.

- **Purple/Black** wire to the right rear (-) speaker output.
- **Blue/Pink** wire to the VSS/speed sense wire.
- Ensure the 4-pin Molex connectors are connected together.
Note: The 4-pin to 4-pin resistor pad harness will not be used in this application.

Cut off and remove the resistors from the wires below the heat shrink:

Green, Green/Black, Purple, and Purple/Black

- **Black/Yellow** wire is used for OnStar level adjustment for models that do not come equipped with steering wheel controls. Refer to the OnStar level Adjustment section for further instructions.
- Connect the **Pink** wire with a red bullet connector to the **Pink** wire from the climate control harness. **Attention!** If this wire is not connected the climate control will fail to function.
- If retaining the factory AUX-IN jack is desired, connect the **Red** and **White** RCA jacks to the audio AUX-IN jacks from the aftermarket radio.

Note: a) The jack can only be used if it is a single jack.

b) If the jack has a USB port as well, neither can be retained.

Note: The relay attached to the car side harness is only for audible turn signal clicks. No extra steps are required to retain this feature, so leave the relay as-is.

Retaining factory backup camera

- To retain the factory backup camera, connect the **Yellow** RCA jack to the backup camera input of the aftermarket radio.

DIN jack: The DIN jack will not be used in this application, please disregard.

Continued on the next page

For models with an amplifier:

From the 16-pin harness with stripped leads to the aftermarket radio, connect as indicated:

- **Red** wire to the accessory wire.
- **Blue/White** wire to the amp turn on wire. This wire must be connected to hear sound from the factory amplifier.
- **Orange/White** wire to the illumination wire. (if applicable)
- **Brown** wire to the mute wire, (if applicable)
Note: If the mute wire is not connected, the radio will turn off when OnStar is activated.
- **Gray** wire to the right front (+) speaker output.
- **Gray/Black** wire to the right front (-) speaker output.
- **White** wire to the left front (+) speaker output.
- **White/Black** wire to the left front (-) speaker output.

The following (3) wires are only for multimedia/navigation radios that require these wires.

- **Blue/Pink** wire to the VSS/speed sense wire.
- **Green/Purple** wire to the reverse wire.
- **Light Green** wire to the parking brake wire

Tape off and disregard the following (4 wires, they will not be used in this application):

- **Green, Green/Black, Purple, Purple/Black**

From the car side harness to the aftermarket radio, connect as indicated:

- **Black** wire to the ground wire.
- **Yellow** wire to the battery wire.
- **Green** wire to the left rear (+) speaker output.

- **Green/Black** wire to the left rear (-) speaker output.
- **Purple** wire to the right rear (+) speaker output.
- **Purple/Black** wire to the right rear (-) speaker output.
- Disconnect the 4-pin Molex connectors and then attach the 4-pin to 4-pin resistor pad harness.
- The **Black/Yellow** wire is used for OnStar level adjustment for models that do not come equipped with steering wheel controls. Refer to the OnStar level Adjustment section for further instructions.
- Connect the **Pink** wire with a red bullet connector to the **Pink** wire from the climate control harness. **Attention!** If this wire is not connected the climate control will fail to function.
- If retaining the factory AUX-IN jack is desired, connect the **Red and White** RCA jacks to the audio AUX-IN jacks from the aftermarket radio.

Note: a) The jack can only be used if it is a single jack.
b) If the jack has a USB port as well, neither can be retained.

Note: The relay attached to the car side harness is only for audible turn signal clicks. No extra steps are required to retain this feature, so leave the relay as-is.

Retaining factory backup camera

- To retain the factory backup camera, connect the **Yellow** RCA jack to the backup camera input of the aftermarket radio.

DIN jack: The DIN jack will not be used in this application, please disregard.

Continue to Programming

PROGRAMMING

With the key in the off position:

1. Connect the 16-pin harness with stripped leads, and the car side harness, into the Axxess interface.
2. Connect the climate control harness to the radio trim panel with climate controls, then to the wiring harness in the vehicle.
3. Locate the factory antenna connector in the dash and complete all necessary connections to the radio. Metra recommends using the proper antenna adapter from Metra.

Attention! Do not connect the car side harness to the wiring harness in the vehicle just yet.

PROGRAMMING THE INTERFACE

For the steps below, the L.E.D. located inside the interface can only be seen while active. The interface does not need to be opened to see the L.E.D.

1. Start the vehicle.
2. Connect the car side harness to the wiring harness in the vehicle. The L.E.D. will initially be solid **Green** to indicate the interface is powered.
3. The L.E.D. will then flash **Red** up to (23) times indicating which radio is connected to the interface, and then turn off for a couple of seconds. Pay close attention to how many Red flashes there are. This will help in troubleshooting, if need be. Refer to the L.E.D. feedback section for more information.

4. After several seconds the L.E.D. will turn on solid **Red** while the interface auto detects the vehicle. The radio will shut off at this point. This process should take (5 to 30) seconds.
 - Once the vehicle has been auto detected by the interface, the L.E.D. will turn on solid **Green**, and the radio will come back on, indicating programming was successful.
6. Test all functions of the installation for proper operation, before reassembling the dash. If the interface fails to function, refer to **Resetting the Interface**.
Note: The L.E.D. will turn on solid **Green** for a moment, and then turn off under normal operation after the key has been cycled.
7. Test all functions of the installation for proper operation, before reassembling the dash.. If the interface fails to function, refer to “Troubleshooting”, “Resetting the Axxess interface”.

Chime level adjustment:

1. With the vehicle on, turn it off and leave the keys in ignition. Open the driver’s door; chimes will be heard.
2. Wait (10) seconds, and then with a small flat-blade screwdriver, turn the potentiometer clockwise to raise the chime level; counterclockwise to lower the chime level.
3. When the chime is at a desired level, remove the keys from the ignition. This will lock the chime volume at its current level.

Continued on the next page

OnStar level adjustment:

PROGRAMMING (CONT.)

1. Press the OnStar button to activate it.
2. While OnStar is speaking, press the VOLUME-UP or VOLUME-DOWN button on the steering wheel to raise or lower the OnStar level.
3. If the vehicle doesn't come equipped with steering wheel controls, locate the **Black/Yellow** wire on the car side harness.
4. While OnStar is speaking, tap the **Black/Yellow** wire to ground. Once the OnStar level is set, it will stay at that level until the **Black/Yellow** wire is tapped to ground again.

Continue to Steering Wheel Control Settings

STEERING WHEEL CONTROL SETTINGS

L.E.D. Feedback: The (23) Red L.E.D. flashes represent a different radio manufacturer for the **SWC interface** to detect. For example, if you are installing a **JVC** radio, the **SWC interface** will flash **Red** (5) times, then stop. Following is the **L.E.D Feedback Legend**, which indicates the flash count of the radio manufacturer.

L.E.D. Feedback Legend

| Flash Count | Radio |
|-------------|--------------------|
| 1 | Eclipse (type 1) † |
| 2 | Kenwood ‡ |
| 3 | Clarion (type 1) † |
| 4 | Sony / Dual |
| 5 | JVC |
| 6 | Pioneer / Jensen |
| 7 | Alpine * |
| 8 | Visteon |
| 9 | Valor |
| 10 | Clarion (type 2) † |
| 11 | Metra OE |
| 12 | Eclipse (type 2) † |

| Flash Count | Radio |
|-------------|------------------|
| 13 | LG |
| 14 | Parrot ** |
| 15 | XITE |
| 16 | Philips |
| 17 | TBA |
| 18 | JBL |
| 19 | Insane |
| 20 | Magnadyne |
| 21 | Boss |
| 22 | Axxera |
| 23 | Axxerra (type 2) |
| | |

KEYNOTES

* If the **SWC interface** flashes **Red** (7) times, and an **Alpine** radio is not installed, that means there is an open connection not accounted for. Verify that the 3.5mm jack is connected to the correct steering wheel jack/wire in the radio.

** The **AXSWCH-PAR** is required (sold separately). Also, the software in the radio must be rev. 2.1.4 or higher.

† If a **Clarion** or **Eclipse** radio is installed and the steering wheel controls do not function, change the radio to **Clarion (type 2)** or **Eclipse (type 2)** respectively. If the steering wheel controls still do not function, refer to the **Changing Radio Type** document on the next page, also available at axxessinterfaces.com.

‡ If a **Kenwood** radio is installed and the L.E.D. feedback flashes (5) times instead of (2), manually change the radio type to **Kenwood**. To do this, refer to the **Changing Radio Type** instructions on the next page, also available at axxessinterfaces.com.

STEERING WHEEL CONTROL SETTINGS *(CONT.)*

Changing Radio Type

1. If the LED flashes do not match the number of the aftermarket radio, the radio will have to be manually programmed.
2. Three (3) seconds after turning the key on, press and hold the **Volume-Down** button on the steering wheel until the L.E.D. in the interface turns a solid green.
3. Release the Volume-Down button; the L.E.D. will go out indicating we are now in **Changing Radio Type** mode.
4. Refer to the Radio Legend to know how many flashes are required to reach the aftermarket radio.
5. Press and hold the **Volume-Up** button until the L.E.D. goes solid, and then release. Repeat this step for the desired radio number you have selected.
6. Once the desired radio number has been selected, press and hold the **Volume-Down** button on the steering wheel until the L.E.D. goes solid. The L.E.D. will remain on for about (3) seconds, while it stores the new radio information.
7. Once the L.E.D. goes off, the **Changing Radio Type** mode will then end. You can now test the steering wheel controls.

Note: If at any time the user fails to press any button for a period longer than (10) seconds, this process will abort.

Note: Refer to **L.E.D. Feedback Legend** for number of flashes, and for more information regarding specific radios.

| Flash Count Radio Legend |
|--------------------------|
| 1. Eclipse (type 1) |
| 2. Kenwood |
| 3. Clarion (type 1) |
| 4. Sony / Dual |
| 5. JVC |
| 6. Pioneer / Jensen |
| 7. Alpine |
| 8. Visteon |
| 9. Valor |
| 10. Clarion (type 2) |
| 11. Metra OE |
| 12. Eclipse (type 2) |
| 13. LG |
| 14. Parrot |
| 15. XITE |
| 16. Philips |
| 17. TBA |
| 18. JBL |
| 19. Insane |
| 20. Magnadyne |
| 21. Boss |
| 22. Axxera |
| 23. Axxera (type 2) |

Continued on the next page

STEERING WHEEL CONTROL SETTINGS (CONT.)

Dual assignment instructions (long button press)

The interface has the capability to assign (2) functions to a single button, except Volume-Up and Volume-Down. Follow the steps below to program the button(s) to your preference.

Note: Seek-Up and Seek-Down come pre-programmed as Preset-Up and Preset-Down for a long button press.

1. Turn on the ignition but do not start the vehicle.
2. Press and hold down the steering wheel control button that you want to assign a long press function to for about (10) seconds, or until the L.E.D. flashes rapidly. At this point release the button; the L.E.D. will then go solid.
3. Press and release the Volume-Up button the number of times corresponding to the new button number selected. Refer to the **Dual Assignment Legend**. The L.E.D. will flash rapidly while the Volume-Up button is being pressed, and then go back to a solid L.E.D. once released. Go to the next step once the Volume-Up button has been pressed the desired number of times.

Caution: If more than (10) seconds elapses between pressing the Volume-Up button, this procedure will abort, and the L.E.D. will go out.

4. To store the long press button in memory, press the button that you assigned a long press button to (the button held down in Step 2). The L.E.D. will now go off indicating the new information has been stored.

Note: These steps must be repeated for each button you would like to assign a dual purpose feature to. To reset a button back to its default state, repeat Step 1, and then press the Volume-Down button. The L.E.D. will go out, and the long press mapping for that button will be erased.

Dual assignment legend

- | | |
|-------------------|-----------------|
| 1. Not allowed | 10. Band |
| 2. Not allowed | 11. Play/Enter |
| 3. Seek-Up/Next | 12. PTT |
| 4. Seek-Down/Prev | 13. On-Hook |
| 5. Mode/Source | 14. Off-Hook |
| 6. ATT/Mute | 15. Fan-Up * |
| 7. Preset-Up | 16. Fan-Down * |
| 8. Preset-Down | 17. Temp-Up * |
| 9. Power | 18. Temp-Down * |

*** Not applicable in this application**

Continued on the next page

STEERING WHEEL CONTROL SETTINGS (CONT.)

Remapping the steering wheel control buttons

The interface makes it possible to change the button assignments on the steering wheel. For example, the Seek-Up button could be reassigned as the Mute button. Follow the steps below to remap the steering wheel control buttons:

1. Turn off the radio and ensure that the LED light on the interface is visible to confirm button recognition
2. Within the first (20) seconds of turning the ignition on, press and hold the Volume-Up button on the steering wheel until the L.E.D. goes solid.
3. Release the Volume-Up button, the L.E.D. will then go out; The Volume-Up button has now been programmed.
4. Follow the list in the Button Assignment Legend to reference the order in which the steering wheel control buttons need to be programmed.

Note: If the next function on the list is not on the steering wheel, press the Volume-Up button for (1) second until the L.E.D. comes on, and then release the Volume-Up button. This will tell the interface that this function is not available and it will move on to the next function.

5. To complete the remapping process, press and hold the Volume-Up button on the steering wheel until the L.E.D. in the interface goes out.

Button assignment legend

- | | |
|-------------------|--------------------------|
| 1. Volume-Up | 10. Band |
| 2. Volume-Down | 11. Play/Enter |
| 3. Seek-Up/Next | 12. PTT (Push to Talk) * |
| 4. Seek-Down/Prev | 13. On-Hook * |
| 5. Source/Mode | 14. Off-Hook * |
| 6. Mute | 15. Fan-Up * |
| 7. Preset-Up | 16. Fan-Down * |
| 8. Preset-Down | 17. Temp-Up * |
| 9. Power | 18. Temp-Down * |

* Not applicable in this application

Note: Not all radios will have all of these commands. Please refer to the manual provided with the radio, or contact the radio manufacturer for specific commands recognized by that particular radio.

Continued on the next page

STEERING WHEEL CONTROL SETTINGS *(CONT.)*

The factory vehicle customization menu is visible on the Metra 107-GM5B screen with use of the factory Center stack buttons. Some buttons also double as additional radio controls (just like the steering wheel controls).

Factory buttons on Non NAV models:

Seek >> – seek up

Seek << - seek down

Radio/band – source

Menu/select- enters menu mode. Also enter button

Silver dial – scrolls through menu options

Back = back

Factory buttons on NAV models:

Seek >> – seek up

Seek << - seek down

CD/AUX/HDD – source

Menu/select- enters menu mode. Also enter button

Silver dial – scrolls through menu options

Back= back

FINAL ASSEMBLY

1. Using the factory screws, secure the radio/bracket assembly to the dash where the factory display was located. (Figure A)
2. Using the factory screws, secure the **Pioneer Modular DDIN** assembly to the dash where the factory chassis was located. (Figure B)
3. Reassemble the dash in the reverse order of disassembly to complete the installation.

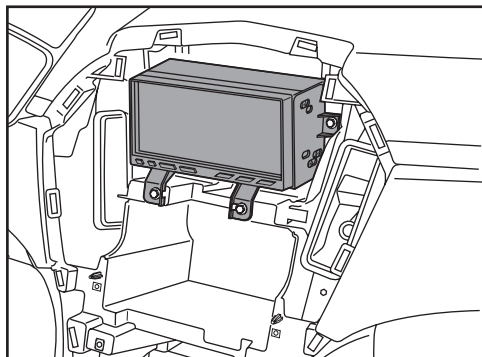

(Figure A)

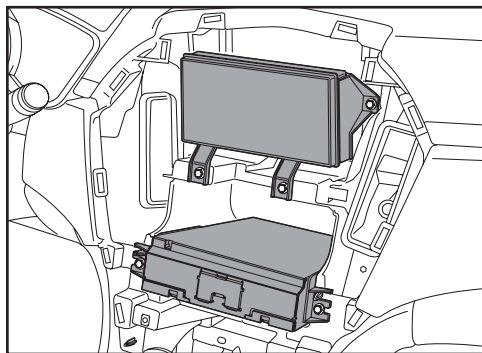

(Figure B)



107-GM5B

INSTALLATION INSTRUCTIONS



Having difficulties? We're here to help.



Contact our Tech Support line at:

386-257-1187



Or via email at:

techsupport@metra-autosound.com

Tech Support Hours (Eastern Standard Time)

Monday - Friday: 9:00 AM - 7:00 PM

Saturday: 10:00 AM - 7:00 PM

Sunday: 10:00 AM - 4:00 PM



® KNOWLEDGE IS POWER

Enhance your installation and fabrication skills by enrolling in the most recognized and respected mobile electronics school in our industry. Log onto www.installerinstitute.com or call 800-354-6782 for more information and take steps toward a better tomorrow.



Metra recommends MECP certified technicians