



Jeep Commander (without NAV) 2006-2007

Visit MetraOnline.com for more detailed information about the product and up-to-date vehicle specific applications

KIT FEATURES

- Designed specifically for the Pioneer DMH-C5500NEX 8-inch radio
- Painted to match the factory finish:
 - 108-CH4G - Gray
 - 108-CH4DK - Dark Khaki

KIT COMPONENTS

- A) Radio bezel • B) Radio brackets • C) Retaining caps • D) Philips screws (4)

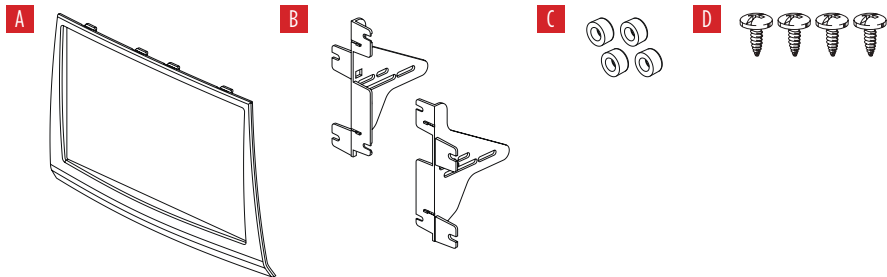

TABLE OF CONTENTS

Dash Disassembly	2
Kit Preparation	3
Kit Assembly	3

WIRING & ANTENNA CONNECTIONS (sold separately)

Wiring Harness: CHT0-01
 Antenna Adapter: 40-CR10

TOOLS REQUIRED

- 9/32" Socket wrench • 5mm Allen screwdriver
- Cutting tool • Panel removal tool
- Phillips screwdriver • Solder gun

Attention! Let the vehicle sit with the key out of the ignition for a few minutes before removing the factory radio. When testing the aftermarket equipment, ensure that all factory equipment is connected before cycling the key to ignition.

DASH DISASSEMBLY

1. Remove (16) 5mm Allen screws securing the dashboard trim panel. (Figure A)
2. Unclip and remove the dashboard trim panel. (Figure B)
3. Remove (4) 9/32" screws securing the radio. Slide the radio out, then unplug and remove.

Continue to Kit Preparation

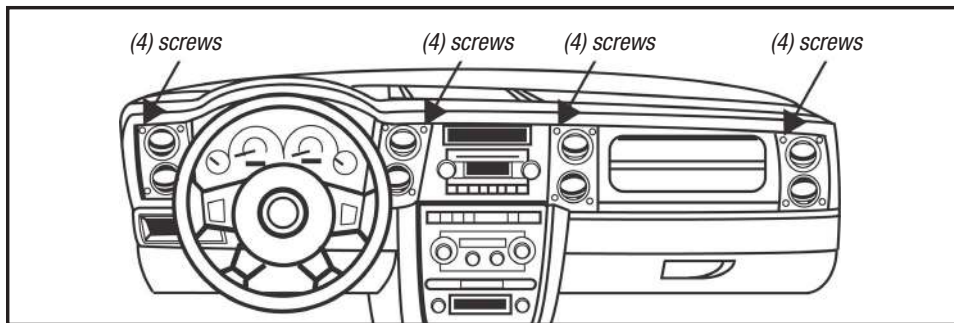

(Figure A)

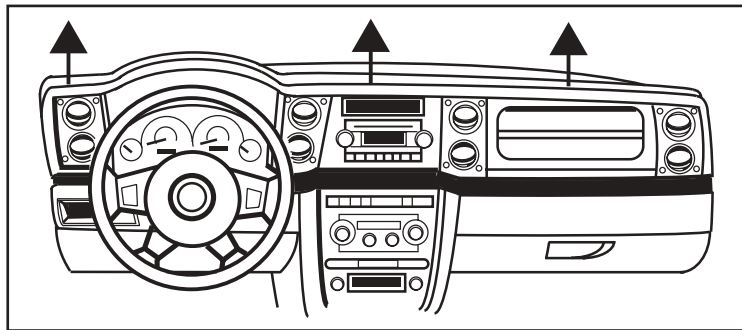

(Figure B)

KIT PREPARATION

From the factory dashboard trim panel:

1. Using either a solder gun or cutting tool, remove the plastic welds holding the factory radio bezel in place. (Figure A)
2. Using a pry tool, remove the factory radio bezel from the center of the factory dash panel.

Note: Be sure NOT to damage the holes in the dash panel, so they can be used for mounting the radio bezel in the next step.

3. Clip the **radio bezel** in, then place the **retaining caps** over the (4) screw holes. Using a manual screwdriver, secure using (4) Phillips screws provided. (Figure B)

Continue to Kit Assembly

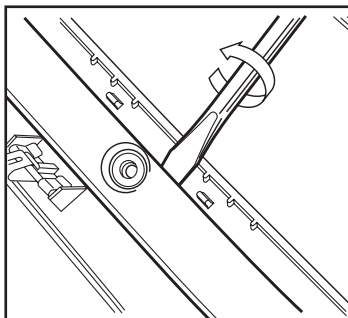

(Figure A)

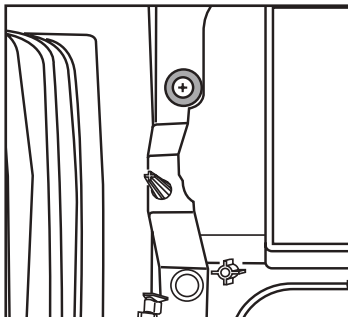

(Figure B)

KIT ASSEMBLY

Attention! For steps 1 and 2, reference the installation manual provided with the radio for which hardware to use. The display screen and radio chassis use two different types of screws

1. Secure the radio chassis to the **radio brackets** using (4) screws supplied with the radio. (Figure B)
2. Secure the display screen to the **radio brackets** using (4) screws supplied with the radio. (Figure A)
3. Locate the factory wiring harness and antenna connector in the dash and complete all necessary connections to the radio. Metra recommends using the proper mating adapter from Metra and/or Axxess. Test the radio for proper operation.
4. Slide the radio into the dash, then secure using the factory screws.
5. Reinstall the dash in reverse order of disassembly to complete the installation.

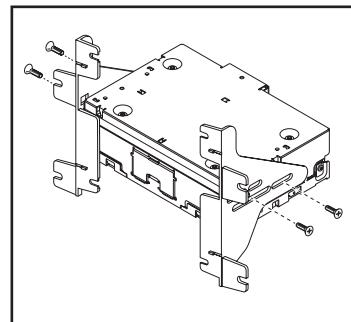

(Figure A)

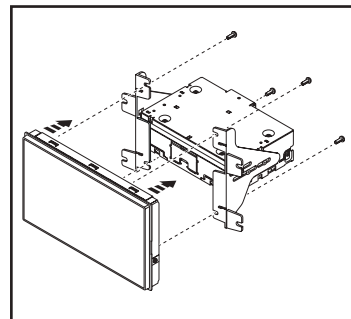

(Figure B)



108-CH4

INSTALLATION INSTRUCTIONS



If you are having difficulties with the installation of this product, contact our Tech Support line either by phone at **386-257-1187**, or email at **techsupport@metra-autosound.com**. Before doing so, look over the instruction booklet a second time and ensure that the installation was performed exactly as the instruction booklet is stated. Have the vehicle apart and ready to perform troubleshooting steps before contacting Metra/Axxess Tech Support.



® KNOWLEDGE IS POWER

Enhance your installation and fabrication skills by enrolling in the most recognized and respected mobile electronics school in our industry. Log onto www.installerinstitute.com or call 800-354-6782 for more information and take steps toward a better tomorrow.



Metra recommends MECP certified technicians