



Toyota RAV4 2019-Up

Visit MetraOnline.com for more detailed information about the product and up-to-date vehicle specific applications

KIT FEATURES

- ISO DDIN radio provision designed for 8" Pioneer modular radios†
- Painted gloss black

† Refer to the radio manufacturer for current models

KIT COMPONENTS

- A) Radio trim panel • B) Radio brackets • C) #4 x 3/8" Phillips screws (4)

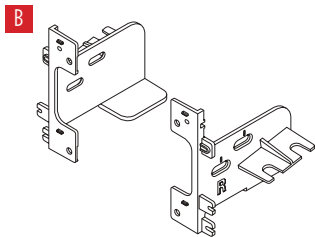
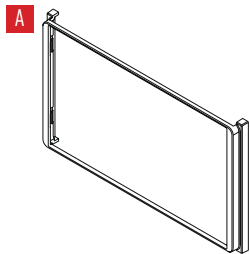

TABLE OF CONTENTS

Dash Disassembly	2
Kit Assembly	3

WIRING & ANTENNA CONNECTIONS (sold separately)

Visit axessinterfaces.com or metraonline.com for harness and interface options
Antenna Adapter: 40-LX11

TOOLS REQUIRED

- Panel removal tool • Phillips screwdriver
- 10mm Socket wrench • Cutting tool

Attention! Let the vehicle sit with the key out of the ignition for a few minutes before removing the factory radio. When testing the aftermarket equipment, ensure that all factory equipment is connected before cycling the key to ignition.

DASH DISASSEMBLY

1. Remove the trim panel behind the radio. (Figure A)
2. Remove (4) 10mm screws securing the radio. Unclip and slide out the radio, then unplug and remove. (Figure B)
3. Remove the (6) screws on radio back and separate panels from around the factory radio face. (Figure C)

Continue to Kit Preparation

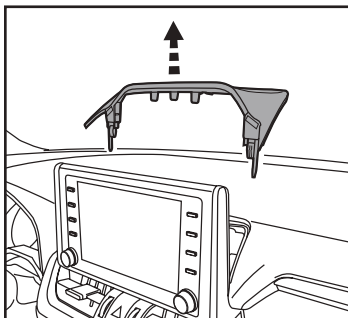

(Figure A)

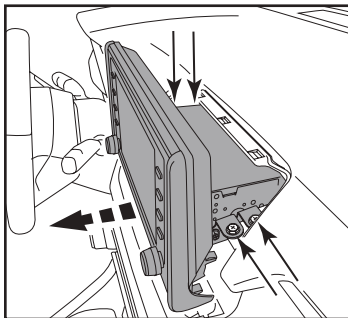

(Figure B)

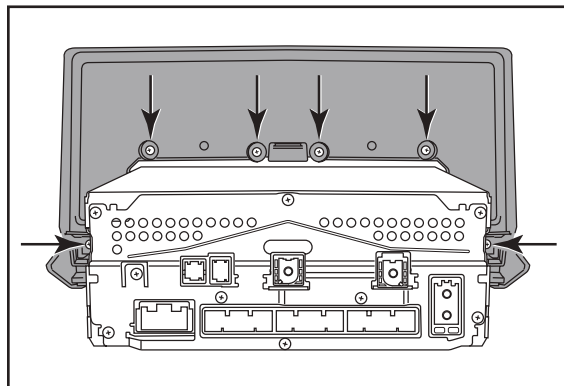

(Figure C)

KIT ASSEMBLY

Pioneer Modular DDIN radio provision

Note: For steps 1 and 2, reference the installation manual provided with the radio for which hardware to use. The display screen and radio chassis use two different types of screws.

1. Secure the radio display to the **radio brackets** using (4) screws supplied with the radio. (Figure A)
2. Secure the **radio brackets** to the radio chassis using (4) screws supplied with the radio. (Figure B)
3. Connect the radio display to the radio chassis.
4. Using a cutting tool, carefully remove the center cross-shaped support brace from the **radio trim panel**.
5. Snap the **radio trim panel** to the new radio display. (Figure C)

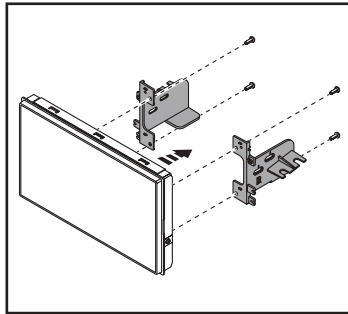

(Figure A)

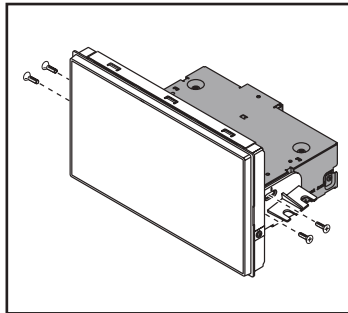

(Figure B)

6. Assemble the radio assembly into the factory radio panels using the outside (4) factory screws (screws are also provided if needed). (Figure D)
7. Locate the factory wiring harness and antenna connector in the dash and complete all necessary connections to the radio. Metra recommends using the proper mating adapter from Metra and/or Axxess. Test the radio for proper operation.
8. Slide the radio assembly into to the dash, then secure using the factory screws.
9. Reassemble the dash in reverse order of disassembly to complete the installation.

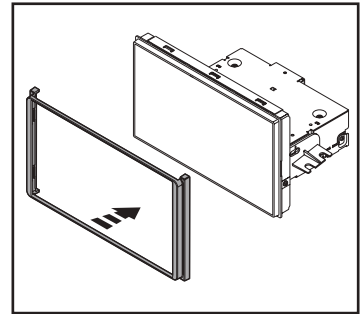

(Figure C)

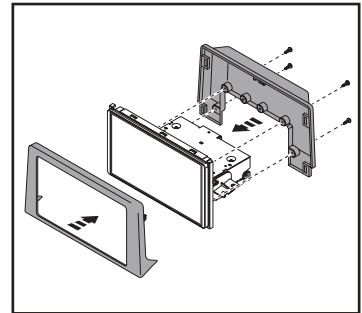

(Figure D)



108-T06HG
INSTALLATION INSTRUCTIONS



Having difficulties? We're here to help.



Contact our Tech Support line at:

386-257-1187



Or via email at:

techsupport@metra-autosound.com

Tech Support Hours (Eastern Standard Time)

Monday - Friday: 9:00 AM - 7:00 PM

Saturday: 10:00 AM - 7:00 PM

Sunday: 10:00 AM - 4:00 PM



® KNOWLEDGE IS POWER

Enhance your installation and fabrication skills by enrolling in the most recognized and respected mobile electronics school in our industry. Log onto www.installerinstitute.com or call 800-354-6782 for more information and take steps toward a better tomorrow.



**Metra recommends MECP
certified technicians**