

SPDT Relay

IMPORTANT

Before starting, compare items on your invoice with items received. Thoroughly check packing materials. If an item is missing, please call **Crutchfield at 1-888-955-6000**.

120 E5000
Revision 05/02/23

About the relay: A relay is a switch controlled by a voltage input instead of a manual action. By sending current through the relay, you can turn a device on or off without touching the device.

APPLICATION: RELAY TURN-ON

The most popular use for the SPDT (single-pole, double-throw) relay is high current on/off switching (for devices that draw up to 30 amps). For example, you could connect a neon light tube to the relay, along with the amplifier turn-on lead from your in-dash receiver. Then the neon light tube will turn on whenever you turn on your in-dash receiver.

You need a constant (unswitched) source of 12 volt power for the relay's red wire. You can tap into your fuse panel or run a wire directly from your positive battery terminal. If you run a wire to your battery, we recommend installing a 30 amp fuse in line, close to the battery connection.

Make wiring connections following instructions on page 3.

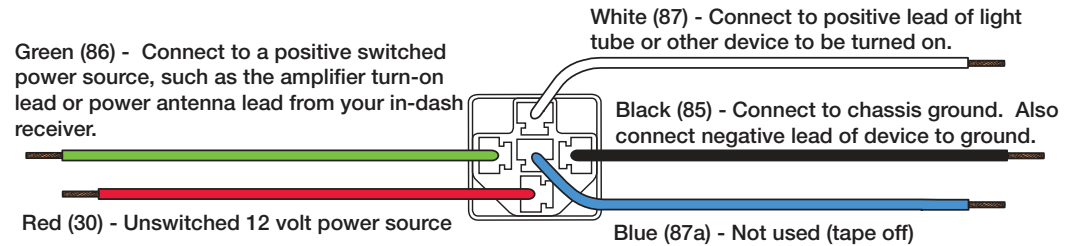

Tape off any unused wires.

APPLICATION: RELAY TURN-OFF

Another popular application is to use the relay to turn off or disable a device. The diagram shows using the relay in conjunction with a car security system to disable your car's starter system.

The diagram shows how you would use a relay with a car security system to disable the starter when the alarm is triggered. To do this, you cut the low-current trigger wire that runs between the ignition switch and the starter solenoid. Connect the red and green wires to the ignition key side of the starter trigger wire. Connect the blue wire to the solenoid side of the starter trigger wire.

Make wiring connections following instructions on page 3.

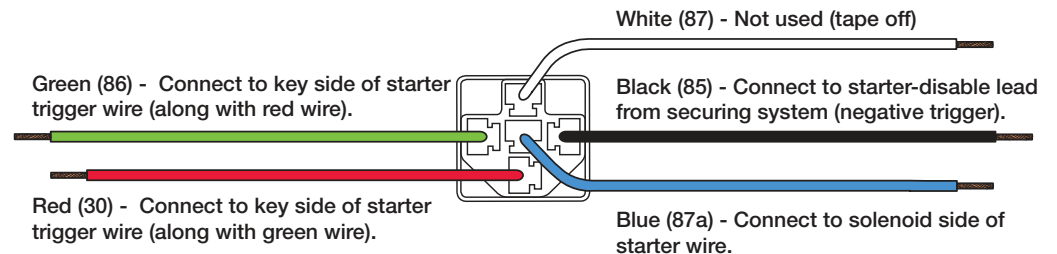

Tape off any unused wires.



SPDT Relay

APPLICATION: REMOTE TRUNK RELEASE

In this application, you use the remote control output from your car security system to open your trunk without the key. You must have an existing power-assisted trunk release switch in your vehicle.

You need a constant (unswitched) source of 12 volt power for the relay's green wire. You can tap into your fuse panel or run a wire directly to your positive battery terminal. If you run a wire to your battery, we recommend installing a 30 amp fuse in line, close to the battery connection.

If your trunk switch doesn't work unless the key is on, connect the red (30) wire together with the green (86) wire to the unswitched 12 volt power source and connect the white (87) wire to the output side of the trunk release switch.

Make wiring connections following instructions on page 3.

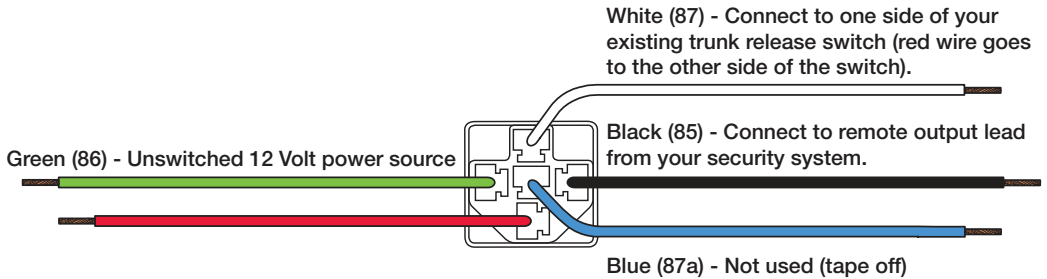

Tape off any unused wires.

APPLICATION: POWER DOOR LOCK SYSTEM

To install aftermarket power door locks and activate them from your security system remote control, you need an "actuator" for each door and two relays.

You need a constant (unswitched) source of 12 volt power for the relay's green and white wires. You can tap into your fuse panel or run a wire directly to your positive battery terminal. If you run a wire to your battery, we recommend installing a 30 amp fuse in line, close to the battery connection.

Make wiring connections following instructions on page 3.

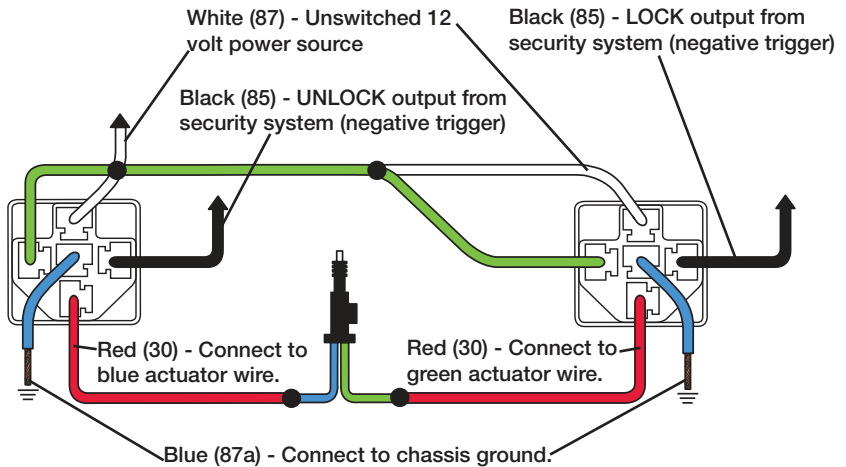

Tape off any unused wires.

● Indicates wire splice

SPDT Relay

APPLICATION: ANTENNA TURN-ON

These instructions apply to 1981-'95 Mazda vehicles with factory-equipped power antennas.

In this application, you use the power antenna output from the car receiver to turn on the power antenna. Your new stereo outputs a 12 volt positive trigger, but your vehicle requires a 12 volt negative input to activate the power antenna. The diagram shows how to use the relay to switch the positive signal to a negative signal. To do this, connect both the black and white wires to chassis ground. Connect the green wire to the power antenna lead on your new stereo. Connect the red wire to the power antenna lead on the receiver wiring adapter. Tape off the blue wire.

Make wiring connections following instructions below.

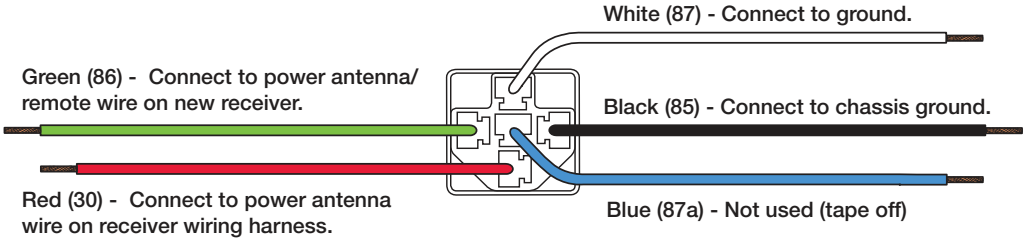

Tape off any unused wires.

WIRING CONNECTIONS

Tools & Parts Required ▼

