

# Cloud Core Router 1036-8G-2S+

---

## Safety Warnings

Before you work on any equipment, be aware of the hazards involved with electrical circuitry and be familiar with standard practices for preventing accidents.

Ultimate disposal of this product should be handled according to all national laws and regulations.

The Installation of the equipment must comply with local and national electrical codes.

Failure to use the correct hardware or to follow the correct procedures could result in a hazardous situation to people and damage to the system.

Read the installation instructions before connecting the system to the power source.



## Quick start

The Ethernet port 1 has a default IP address for connecting: 192.168.88.1. Username is admin and there is no password. The device doesn't have any other configuration applied by default, please set up WAN IP addresses, user password, and update the device.

Connecting the device to the internet:

- Connect your ISP Ethernet cable to the Ethernet port1;
- Connect with your PC to the Ethernet port3;
- Open WinBox on your computer and check Neighbors tab for CCR;
- Choose the device and connect;
- Choose Quick Set on the left side of the screen;
- Set address Acquisition to automatic, or enter your Network details manually;
- Set your local Network IP Address 192.168.88.1;
- Type a secure password in the Password field and confirm again;
- Click Apply;
- The device will receive an IP if your Network has DHCP server enabled, or if you have entered Network details correct and internet connection will be available.
- Click on the Check for updates and on newly opened window choose Download&Install if new version if available.
- You are ready to use your device.

RouterOS includes many configuration options in addition to what is described in this document. We suggest starting here to get yourself accustomed to the possibilities: <http://mt.lv/help>. In case the IP connection is not available, the Winbox tool (<http://mt.lv/winbox>) can be used to connect to the MAC address of the device from the LAN side

## Powering

The device has dual removable (hot-swap compatible) power supply units AC ~ 110-240V with standard IEC compatible sockets. Maximum power consumption of 73 W.

## Reset button

The reset button has two functions:

- Hold this button during boot time until LED light starts flashing, release the button to reset RouterOS configuration.
- Or Keep holding the button for 5 more seconds until LED turns off, then release it to make the RouterBOARD look for Netinstall servers.

Regardless of the above option used, the system will load the backup RouterBOOT loader if the button is pressed before power is applied to the device. Useful for RouterBOOT debugging and recovery.

## Mounting

The device is designed to use indoors and it can be mounted in a rackmount enclosure using provided rack mounts, or it can be placed on the desktop. Use a Phillips screwdriver to attach rackmount ears on both sides of the device if designated use is for rackmount enclosure:

1. Attach rack ears to both sides of the device and tighten four screws to secure them in place, as shown on the picture to the right;

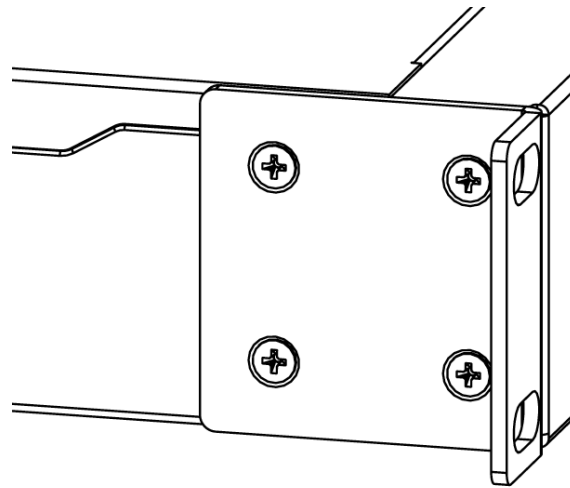

2. Place the device in rackmount enclosure and align with the holes so that the device fits conveniently;
3. Tighten screws to secure it in place.



The IP rating scale for this device is IPX0. The device has no protection from water contamination, please ensure the placement of the device in a dry and ventilated environment. We recommend Cat6 cables for our devices.

## LEDs

The device has four LED lights. PWR1/2 indicates which power supply is being used. FAULT indicates a problem with the cooling fans. USER can be configured in software.

## Operating System Support

The device supports RouterOS software with the version number v6.46 at or above what is indicated in the RouterOS menu `/system resource`. Other operating systems have not been tested.

## PCIe usage

M.2 Slot PCIe 4x, to install SSD please follow instructions:

1. Turn off device (unplug power cords);
2. Unscrew 6 screws which hold CCR upper lid;
3. Open lid;
4. Unscrew screw which will hold SSD;
5. Insert SSD in m.2 slot;
6. Attach power cords and check does SSD properly initializing;
7. Screw back 6 lid screws.

*Also please note, that by default you should use m.2 2280 form factor SSD.*

# CE Declaration of Conformity



Manufacturer: Mikrotikls SIA, Brivibas gatve 214i Riga, Latvia, LV1039.

BG	С настоящото Mikrotikls SIA декларира, че този тип радиосъоръжение RouterBOARD е в съответствие с Директива 2014/53/ЕС. Цялостният текст на ЕС декларацията за съответствие може да се намери на следния интернет адрес: <a href="https://mikrotik.com/products">https://mikrotik.com/products</a>
CS	Tímto Mikrotikls SIA prohlašuje, že typ rádiového zařízení RouterBOARD je v souladu se směrnicí 2014/53/EU. Úplné znění EU prohlášení o shodě je k dispozici na této internetové adrese: <a href="https://mikrotik.com/products">https://mikrotik.com/products</a>
DA	Hermed erklærer Mikrotikls SIA, at radioudstyrstypen RouterBOARD er i overensstemmelse med direktiv 2014/53/EU. EU-overensstemmelseserklæringens fulde tekst kan findes på følgende internetadresse: <a href="https://mikrotik.com/products">https://mikrotik.com/products</a>
DE	Hiermit erklährt Mikrotikls SIA, dass der Funkanlagentyp RouterBOARD der Richtlinie 2014/53/EU entspricht. Der vollständige Text der EU-Konformitätserklärung ist unter der folgenden Internetadresse verfügbar: <a href="https://mikrotik.com/products">https://mikrotik.com/products</a>
EL	Με την παρούσα ο/η Mikrotikls SIA, δηλώνει ότι ο ραδιοεξοπλισμός RouterBOARD πληροί την οδηγία 2014/53/ΕΕ. Το πλήρες κείμενο της δήλωσης συμμόρφωσης ΕΕ διατίθεται στην ακόλουθη ιστοσελίδα στο διαδίκτυο: <a href="https://mikrotik.com/products">https://mikrotik.com/products</a>
EN	Hereby, Mikrotikls SIA declares that the radio equipment type RouterBOARD is in compliance with Directive 2014/53/EU. The full text of the EU declaration of conformity is available at the following internet address: <a href="https://mikrotik.com/products">https://mikrotik.com/products</a>
ES	Por la presente, Mikrotikls SIA declara que el tipo de equipo radioeléctrico RouterBOARD es conforme con la Directiva 2014/53/UE. El texto completo de la declaración UE de conformidad está disponible en la dirección Internet siguiente: <a href="https://mikrotik.com/products">https://mikrotik.com/products</a>
ET	Käesolevaga deklareerib Mikrotikls SIA, et käesolev raadioseadme tüüp RouterBOARD vastab direktiivi 2014/53/EL nõuetele. ELi vastavusdeklaratsiooni täielik tekst on kättesaadav järgmisel internetiaadressil: <a href="https://mikrotik.com/products">https://mikrotik.com/products</a>
FI	Mikrotikls SIA vakuuttaa, että radiolaitetyypin RouterBOARD on direktiivin 2014/53/EU mukainen. EU-vaatimustenmukaisuusvakuutuksen täysimittainen teksti on saatavilla seuraavassa internetosoitteessa: <a href="https://mikrotik.com/products">https://mikrotik.com/products</a>
FR	Le soussigné, Mikrotikls SIA, déclare que l'équipement radioélectrique du type RouterBOARD est conforme à la directive 2014/53/UE. Le texte complet de la déclaration UE de conformité est disponible à l'adresse internet suivante: <a href="https://mikrotik.com/products">https://mikrotik.com/products</a>
HR	Mikrotikls SIA ovime izjavljuje da je radijska oprema tipa RouterBOARD u skladu s Direktivom 2014/53/EU. Cjeloviti tekst EU izjave o sukladnosti dostupan je na sljedećoj internetskoj adresi: <a href="https://mikrotik.com/products">https://mikrotik.com/products</a>
HU	Mikrotikls SIA igazolja, hogy a RouterBOARD típusú rádióberendezés megfelel a 2014/53/EU irányelvnek. Az EU-megfelelőségi nyilatkozat teljes szövege elérhető a következő internetes címen: <a href="https://mikrotik.com/products">https://mikrotik.com/products</a>
IT	Il fabbricante, Mikrotikls SIA, dichiara che il tipo di apparecchiatura radio RouterBOARD è conforme alla direttiva 2014/53/UE. Il testo completo della dichiarazione di conformità UE è disponibile al seguente indirizzo Internet: <a href="https://mikrotik.com/products">https://mikrotik.com/products</a>
IS	Hér með lýsir Mikrotikls SIA því yfir að RouterBOARD er í samræmi við grunnkröfur og aðrar kröfur, sem gerðar eru í tilskipun 2014/53/EU. Fullur texti ESB samræmisýfirlýsingar er að finna á eftirfarandi veffangi: <a href="https://mikrotik.com/products">https://mikrotik.com/products</a>
LT	Aš, Mikrotikls SIA, patvirtinu, kad radijo įrenginių tipas RouterBOARD atitinka Direktyvą 2014/53/ES. Visas ES atitikties deklaracijos tekstas prieinamas šiuo interneto adresu: <a href="https://mikrotik.com/products">https://mikrotik.com/products</a>
LV	Ar šo Mikrotikls SIA deklarē, ka radioiekārta RouterBOARD atbilst Direktīvai 2014/53/ES. Pilns ES atbilstības deklarācijas teksts ir pieejams šādā interneta vietnē: <a href="https://mikrotik.com/products">https://mikrotik.com/products</a>
MT	B'dan, Mikrotikls SIA, niddikjara li dan it-tip ta' taġhmir tar-radju RouterBOARD huwa konformi mad-Direttiva 2014/53/UE. It-test kollu tad-dikjarazzjoni ta' konformità tal-UE huwa disponibbli f'dan l-indirizz tal-Internet li ġej: <a href="https://mikrotik.com/products">https://mikrotik.com/products</a>
NL	Hierbij verklaar ik, Mikrotikls SIA, dat het type radioapparatuur RouterBOARD conform is met Richtlijn 2014/53/EU. De volledige tekst van de EU-conformiteitsverklaring kan worden geraadpleegd op het volgende internetadres: <a href="https://mikrotik.com/products">https://mikrotik.com/products</a>
NO	Mikrotikls SIA erklærer herved at utstyret RouterBOARD er i samsvar med de grunnleggende krav og øvrige relevante krav i direktiv 2014/53/EU. Den fulle teksten til EU-samsvarserklæringen er tilgjengelig på følgende internetadresse: <a href="https://mikrotik.com/products">https://mikrotik.com/products</a>
PL	Mikrotikls SIA niniejszym oświadcza, że typ urządzenia radiowego RouterBOARD jest zgodny z dyrektywą 2014/53/UE. Pełny tekst deklaracji zgodności UE jest dostępny pod następującym adresem internetowym: <a href="https://mikrotik.com/products">https://mikrotik.com/products</a>
PT	O(a) abaixo assinado(a) Mikrotikls SIA declara que o presente tipo de equipamento de rádio RouterBOARD está em conformidade com a Diretiva 2014/53/UE. O texto integral da declaração de conformidade está disponível no seguinte endereço de Internet: <a href="https://mikrotik.com/products">https://mikrotik.com/products</a>
RO	Prin prezenta, Mikrotikls SIA declară că tipul de echipamente radio RouterBOARD este în conformitate cu Directiva 2014/53/UE. Textul integral al declarației UE de conformitate este disponibil la următoarea adresă internet: <a href="https://mikrotik.com/products">https://mikrotik.com/products</a>
SK	Mikrotikls SIA týmto vyhlasuje, že rádiové zariadenie typu RouterBOARD je v súlade so smernicou 2014/53/EÚ. Úplné EÚ vyhlásenie o zhode je k dispozícii na tejto internetovej adrese: <a href="https://mikrotik.com/products">https://mikrotik.com/products</a>
SL	Mikrotikls SIA potrjuje, da je tip radijske opreme RouterBOARD skladen z Direktivo 2014/53/EU. Celotno besedilo izjave EU o skladnosti je na voljo na naslednjem spletnem naslovu: <a href="https://mikrotik.com/products">https://mikrotik.com/products</a>
SV	Härmed försäkrar Mikrotikls SIA att denna typ av radioutrustning RouterBOARD överensstämmer med direktiv 2014/53/EU. Den fullständiga texten till EU-försäkran om överensstämmelse finns på följande webbadress: <a href="https://mikrotik.com/products">https://mikrotik.com/products</a>

Note. Information contained here is subject to change. Please visit the product page on [www.mikrotik.com](http://www.mikrotik.com) for the most up to date version of this document.



**BG. Инструкции:** Свържете адаптера на захранване, за да включите устройството. Отворете 192.168.88.1 в уеб браузър, за да настроите продукта. Повече информация в <https://mt.lv/help-bg>

**CS. Návod k použití:** Připojte napájecí adaptér k zapnutí přístroje. Otevřete 192.168.88.1 ve webovém prohlížeči pro konfiguraci produktu. Více informací najdete v <https://mt.lv/help-cs>

**DA. Instruktionsbog:** Tilslut strømadapteren for at tænde for enheden. Åbn 192.168.88.1 i en webbrowser til at konfigurere produktet. Mere information i <https://mt.lv/help-da>

**DE. Bedienungsanleitung:** Verbinden Sie das Netzteil, um das Gerät einzuschalten. Öffnen Sie 192.168.88.1 in einem Web-Browser, um das Produkt zu konfigurieren. Weitere Informationen im <https://mt.lv/help-de>

**EL. εγχειρίδιο οδηγιών:** Συνδέστε τον προσαρμογέα τροφοδοσίας για να ενεργοποιήσετε τη μονάδα. Ανοίξτε 192.168.88.1 σε ένα πρόγραμμα περιήγησης στο Web για να διαμορφώσετε το προϊόν. Περισσότερες πληροφορίες στο <https://mt.lv/help-el>

**EN. Instruction manual:** Connect the power adapter to turn on the device. Open 192.168.88.1 in your web browser, to configure it. More information on <https://mt.lv/help>

**ES. Manual de instrucciones:** Conecte el adaptador de alimentación para encender la unidad. Abra 192.168.88.1 en un navegador web para configurar el producto. Más información en <https://mt.lv/help-es>

**ET. Kasutusjuhend:** Ühendage toiteadapter seadme sisselülitamiseks. Avatud 192.168.88.1 in veebilehitseja seadistada toodet. Rohkem teavet <https://mt.lv/help-et>

**FI. Käyttöohje:** Kytke virtalähde päälle laitteen. Avaa 192.168.88.1 in selaimen määrittää tuotteen. Lisää tietoa <https://mt.lv/help-fi>

**FR. Mode d'emploi:** Connectez l'adaptateur d'alimentation pour allumer l'appareil. Ouvrez 192.168.88.1 dans un navigateur Web pour configurer le produit. Plus d'informations dans <https://mt.lv/help-fr>

**HR. Uputa za uporabu:** Priključite napajanje i uključite uređaj. Za konfiguraciju uređaja u pregledniku otvorite 192.168.88.1. Više informacija je na <https://mt.lv/help-hr>

**HU. Használati utasítás:** Csatlakoztassa a hálózati adaptert a készülék bekapcsolásához. Megnyitása 192.168.88.1 egy webböngészőben beállítani a terméket. Több információ <https://mt.lv/help-hu>

**IT. Manuale di istruzioni:** Collegare l'adattatore di alimentazione per accendere l'unità. Aprire 192.168.88.1 in un browser Web per configurare il prodotto. Maggiori informazioni in <https://mt.lv/help-it>

**IS. Notkunarleiðbeiningar:** Tengdu straumbreytinn til að kveikja á tækinu. Opnaðu 192.168.88.1 í vafra til að stilla það. Nánari upplýsingar á <https://mt.lv/help-is>

**NO. Instruksjonsmanual:** Koble strømadapteren for å slå på enheten. Åpne 192.168.88.1 i nettleseren din for å konfigurere den. Mer informasjon på <https://mt.lv/help-no>

**LT. Naudojimosi instrukcija:** Prijunkite maitinimo adapterį įjunkite įrenginį. Į interneto naršyklę 192.168.88.1 Atidarykite galite konfigūruoti gaminį. Daugiau informacijos rasite <https://mt.lv/help-lt>

**LV. Lietošanas instrukcija:** Pievienojiet Strāvas adapteri, lai ieslēgtu ierīci. Atvērt 192.168.88.1 ar interneta pārlūku, lai konfigurētu produktu. Plašāka informācija <https://mt.lv/help-lv>

**MT. Manwal tal-istruzzjoni:** Qabbad l-adapter tal-qawwa biex iddawwar it-tagħmir. Iftaħ 192.168.88.1 fil-web browser tiegħek, biex jiġi kkonfigurati. Aktar informazzjoni fuq <https://mt.lv/help-mt>

**NL. Handleiding:** Sluit voedingsadapter aan op het apparaat in te schakelen. Open 192.168.88.1 in een webbrowser om het product te configureren. Meer informatie in <https://mt.lv/help-nl>

**PL. Instrukcja obsługi:** Podłącz adapter zasilania, aby włączyć urządzenie. Otwórz 192.168.88.1 w przeglądarce internetowej, aby skonfigurować urządzenie. Więcej informacji w <https://mt.lv/help-pl>

**PT. Manual de instruções:** Conecte o adaptador de alimentação para ligar o aparelho. Abra 192.168.88.1 em um navegador da web para configurar o produto. Mais informações em <https://mt.lv/help-pt>

**RO. Instrucțiuni de utilizare:** Conectați adaptorul de alimentare pentru a porni aparatul. Deschide 192.168.88.1 într-un browser web pentru a configura produsul. Mai multe informații în <https://mt.lv/help-ro>

**SK. Navodila:** Priključite napajalnik za vklop naprave. Odprite 192.168.88.1 v spletnem brskalniku nastaviti izdelek. Več informacij v <https://mt.lv/help-sk>

**SL. Návod na pužitie:** Pripojte napájací adaptér k zapnutiu přístroja. Otvorte 192.168.88.1 vo webovom prehliadači pre konfiguráciu produktu. Viac informácií nájdete v <https://mt.lv/help-sl>

**SV. Instruktionsmanual:** Anslut nätadaptern för att slå på enheten. Öppna 192.168.88.1 i en webbläsare för att konfigurera produkten. Mer information på <https://mt.lv/help-sv>

**NO. Bruksanvisningen:** Koble strømadapteren for å slå på enheten. Åpne 192.168.88.1 i en netleser for å konfigurere produktet. Mer informasjon på <https://mt.lv/help-no>

**RU. Руководство по эксплуатации:** подключите адаптер питания чтобы включить устройство. Откройте 192.168.88.1 в своем веб-браузере для конфигурации. Дополнительная информация <https://mt.lv/help-ru>

**CN. 说明书:** 连接电源适配器以打开设备。在 Web 浏览器中打开 192.168.88.1 进行配置。有关 <https://mt.lv/help-zh> 的更多信息

**UA. Керівництво з експлуатації:** підключіть адаптер живлення щоб увімкнути пристрій. Відкрийте 192.168.88.1 в своєму веб-браузері для конфігурації. Додаткова інформація: <https://mt.lv/help-ua>