

Installation Manual



10387-X KIT

Ford F-250 F-350 & F-450 Super Duty (2WD/4WD)*

Eliminate your vehicle's sag, sway and bottoming out while providing added support for an overall smooth and safe ride with this extreme duty air suspension kit. Rated for up to 7500 lbs of load-leveling capacity⁺, this kit is ideally suited for those towing/hauling big loads on a regular basis.

* See application guide for proper fitment.

+ Applications vary. Never exceed manufacturer's recommended Gross Vehicle Weight Rating



WARNING: This product can expose you to the chemical Hexavalent Chromate, which is known to the State of California to cause cancer and birth defects or other reproductive harm. *For more information go to www.P65Warnings.ca.gov*

Thank you and congratulations on the purchase of an air suspension kit. Please read the entire manual prior to starting the installation to ensure you can complete it once started.

IMPORTANT

This air suspension kit will not increase the GVWR (*Gross Vehicle Weight Rating*), as the GVWR is determined by the vehicle manufacturer. **Do not exceed the maximum capacity listed by the vehicle manufacturer.**

Safety Warning!

Serious personal injury or death may result from an air spring failure or accident due to improper installation or air spring pressure operation or maintenance. Please read and abide the instructions, safety recommendations and maintenance suggestions throughout this manual.

Safety Warning!

Inflating an unsecured air spring is dangerous. If it bursts, it could be hurled into the air with explosive force resulting in serious personal injury or death. Never inflate an air spring unless it is secured to the vehicle.

Safety Warning!

Removing and replacing air springs can be dangerous. This is only a job for a qualified service professional. Never perform air spring service procedures without proper training, tools, and equipment.

.....

KIT CONTENTS

Reference the kit explosion diagrams on the following pages for part assembly.

KIT CONTENTS			QTY	PART #	REQUIRED TOOLS
A	Extreme Duty Air Spring	2	HP10438	<ul style="list-style-type: none"> • Hoist or Floor Jack • Safety Stands • Safety Glasses • Torque Wrench • Standard Combination Wrenches • 7/32" Hex Allen Wrench • 1-1/8" Wrench or Deep Socket • Ratchet • Metric & Standard Sockets • Hose Cutter (included) or Sharp Utility Knife • Pipe Thread Sealant • Spray Bottle with Dish Soap/Water • Air Compressor/Compressed Air Source (to test/fill air springs) 	
B	Roll Plate	4	HP10069		
C	Lower Air Spring Bracket	2	HP1673		
D	Lower Axle Bracket	2	HP1674		
E	Upper Driver Bracket	1	HP1679		
F	Upper Passenger Bracket	1	HP1682		
G	L-Bracket	1	HP1379		
H	Spacer	2	HP1364		
I	Axle Strap	2	HP1678		
J	U-Bolt, 3/8" – 16 X 7" X 5.5" Square	2	HP1486		
K	Bolt, 1/4" – 20 X 1" Hex Head	1	P34637		
L	Bolt, 5/16" – 24 X 1" Hex Head	1	C10465		
M	Bolt, 3/8" – 24 X 7/8" Hex Head	4	HP1002		
N	Bolt, 3/8" – 24 X 3/4" Countersunk	4	HP1008		
O	Bolt, 3/8" – 16 X 1.5" Hex Head	8	HP1646		
P	Bolt, 3/8" – 16 X 2" Carriage	2	HP1447		
Q	Bolt, 3/8" – 16 X 6" Carriage	4	HP1685		
R	Bolt, 1/2" – 13 X 1.25" Hex Head	2	HP1371		
S	Bolt, 1/2" – 13 X 3" Hex Head	2	HP1324		
T	Washer, 1/4" Flat	2	P02190		
U	Washer, 5/16" Flat	2	C11944		
V	Washer, 3/8" Flat	28	C653		
W	Washer, 3/8" Split Lock	4	C18007		
X	Washer, 1/2" X 1.375" OD Flat	3	HP1368		
Y	Washer, 1/2" X 2" OD Thin Flat	2	HP1010		
Z	Washer, 1/2" X 2" OD Thick Flat	2	HP1369		
AA	Washer, 3/4" Flat	1	HP1446		
BB	Nut, 1/4" Nylon Lock	1	HP1072		
CC	Nut, 5/16" Nylon Lock	1	C10450		
DD	Nut, 3/8" Nylon Lock	16	HP1000		
EE	Nut, 3/8" Serrated Flange	2	HP1338		
FF	Nut, 1/2" Serrated Flange	2	HP1370		
GG	Heat Shield	1	HP0012		
HH	Worm Gear Ring Clamp	2	HP1377		
II	Fitting, Straight Brass	2	HP1385		

Please make sure all the items shown in this explosion diagram are provided in your kit before starting the installation.

DRIVER SIDE ASSEMBLY SHOWN:

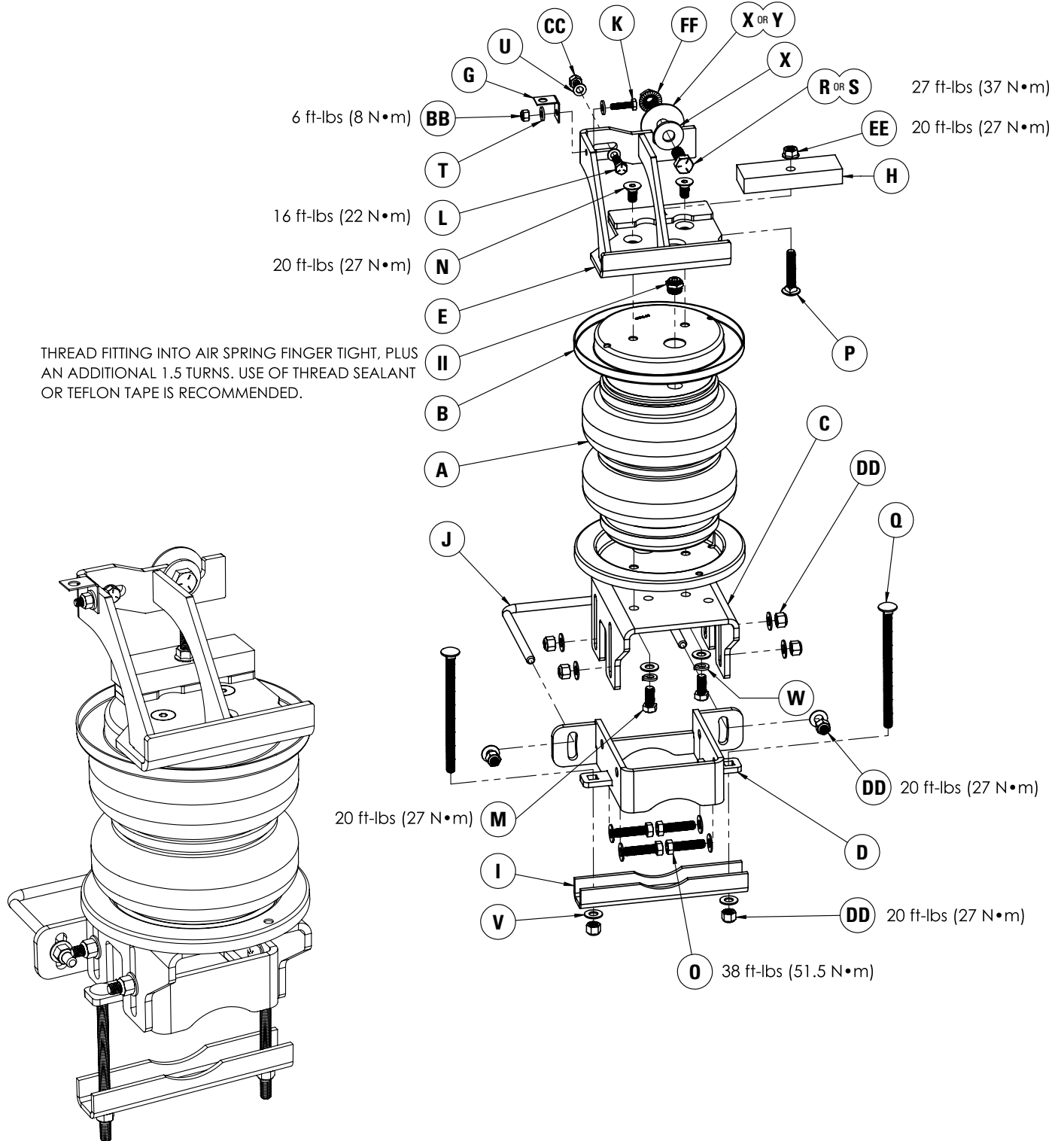

Please make sure all the items shown in this explosion diagram are provided in your kit before starting the installation.

PASSENGER SIDE ASSEMBLY SHOWN:

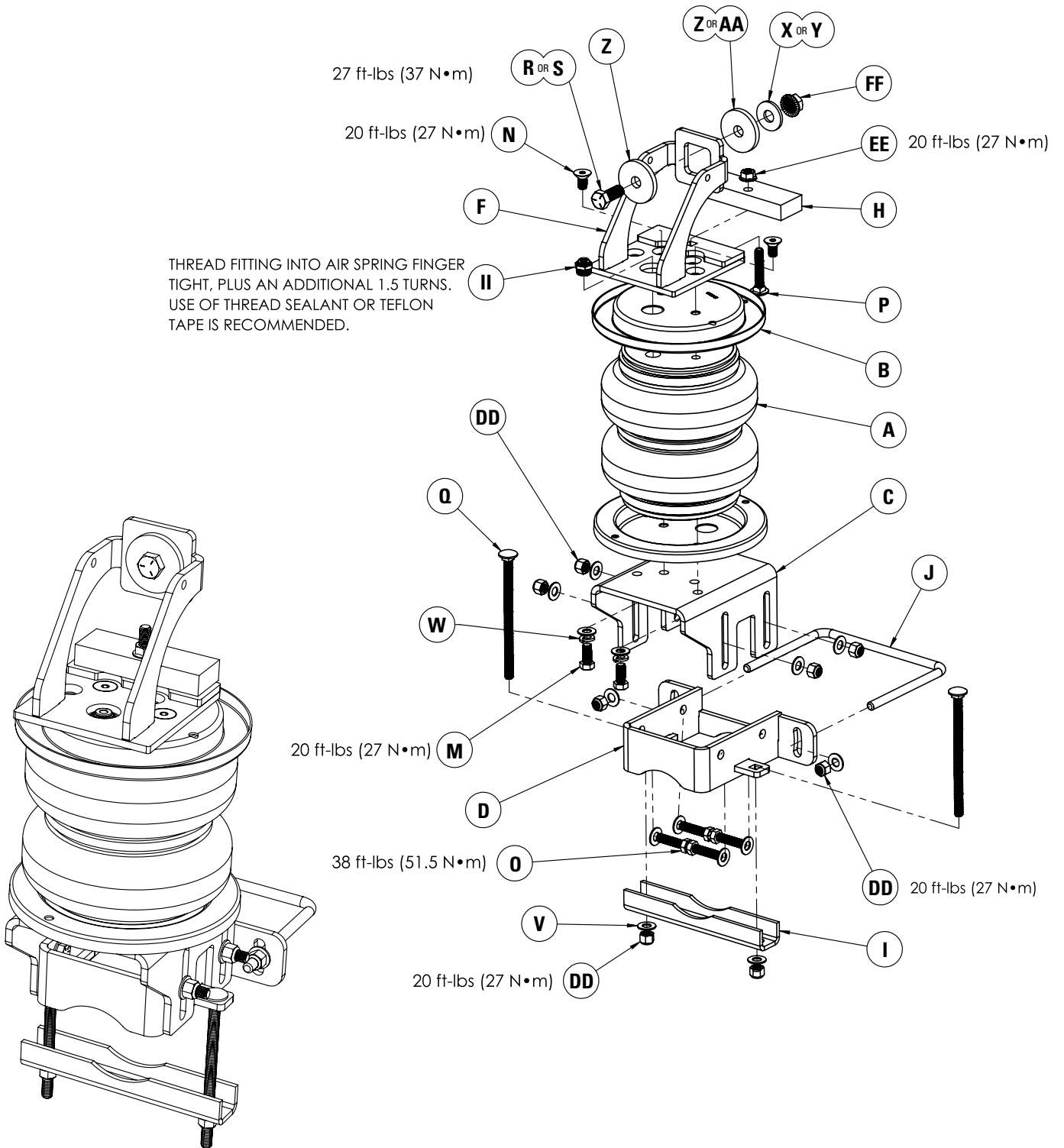

BEFORE STARTING THE INSTALLATION:

1. Ensure the application information is correct for the make, model and year of the vehicle you are installing the kit on.
2. Some vehicles are equipped with a rear wheel brake proportioning valve. Check with the manufacturer before installing the air spring kit, as it may affect braking performance.
3. It is recommended to use a good quality anti-seize on all fasteners. This will reduce the chance of corrosion on the fasteners and will help facilitate removal, if required at a later date.

PLEASE NOTE:

This kit contains push-to-connect fittings; using scissors or wire cutters to cut the nylon airline will distort the line and cause the connection to leak. THE AIRLINE MUST BE CUT OFF SQUARELY WITH THE NYLON HOSE CUTTER PROVIDED IN THIS KIT OR A SHARP UTILITY KNIFE.

1 MEASURE STOCK RIDE HEIGHT

Park the vehicle on a level surface. Remove any unnecessary weight from the vehicle to attain a Normal Ride Height. This is important for correct initial air spring set-up and adjustment.

Using a measuring tape, measure the distance between the center of the wheel hub and the bottom of the fender well (as shown in Figure 1) this will give you your ride height.

Note the ride height for all four corners.

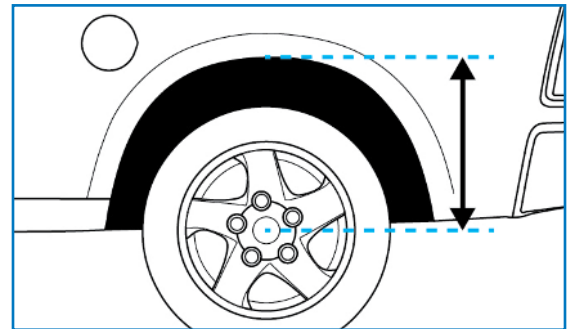

1

2 REMOVE REAR WHEELS

Place wheel chocks in front of and behind both front wheels.

Raise the rear of the truck high enough to remove both wheels and attain a comfortable working height.

Place two jack stands under rear axle (shown in Figure 2).

Lower the vehicle until the axle is supported by the jack stands.

Remove rear wheels.



2

3 REMOVE JOUNCE BUMPER, EMISSION LINE CLIP & AFTERMARKET FIFTH WHEEL HARDWARE (IF EQUIPPED)

Remove the flange nut securing the jounce bumper to the frame rail using a 13mm wrench or socket. (See Figure 3A). Discard the nuts as they will not be reused in this installation.

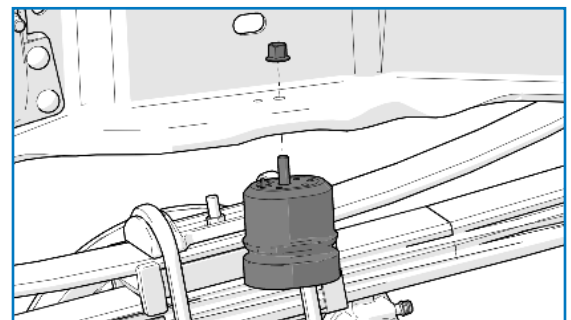

3A

Step continues on following page...

If the truck is equipped with an aftermarket fifth wheel hitch that uses the slotted hole in the frame above the jounce bumper mounting location (shown in Figure 3B), remove the hardware bolting the hitch plate to the frame. Keep all hardware for reinstallation with kit upper brackets.

If the truck is equipped with an emission line running inside the frame, it must be relocated to allow fitment of the upper driver bracket. On the driver's side, check if a line is clipped to the hole above the jounce bumper (shown in Figure 3C).

If equipped, carefully remove the harness clip from the frame hole and gently pull the lines upwards.

4 INSTALL AIR FITTINGS

Install the straight brass fitting into each air spring (as shown in Figure 4).

Thread the fitting finger tight plus an additional 1.5 turns. The use of thread sealant or Teflon tape is recommended.

Set a roll plate (as shown) on the top surface of the air spring after the fitting is tightened.

5 INSTALL SPACERS ON UPPER BRACKETS

Install a spacer on each upper bracket (as shown with an arrow in Figure 5A) with a 3/8" – 16 X 2" Carriage Bolt.

Ensure the long side of the spacer (indicated with an arrow in Figure 5B) faces away from the air spring mounting holes.

6 ATTACH UPPER PASSENGER BRACKET TO AIR SPRING

Assemble the passenger side spring assembly (as shown in Figure 6 on the following page) by placing the upper passenger bracket with spacer on the air spring and roll plate.

Align the indicated bracket holes with the holes in the roll plate and air spring and secure using two 3/8" – 24 X 3/4" Countersunk bolts.

Torque bolts to 20 ft-lbs (27 N•m).

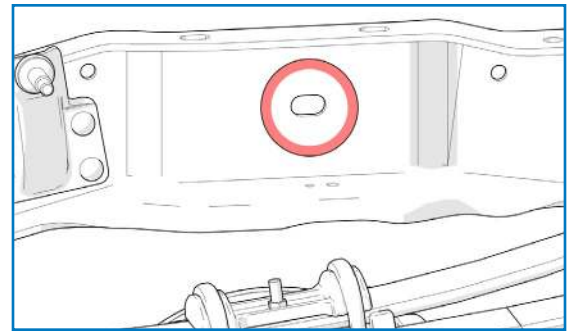

3B

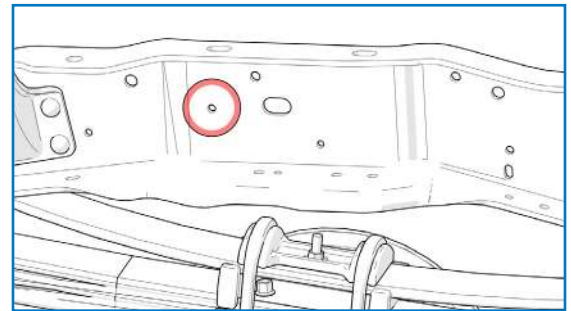

3C

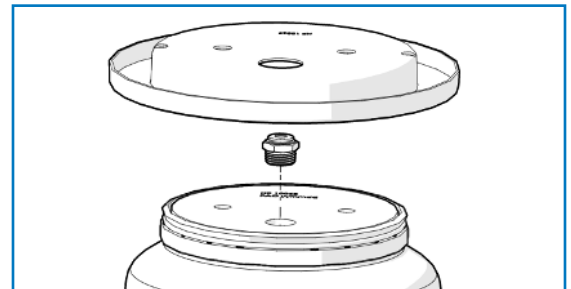

4

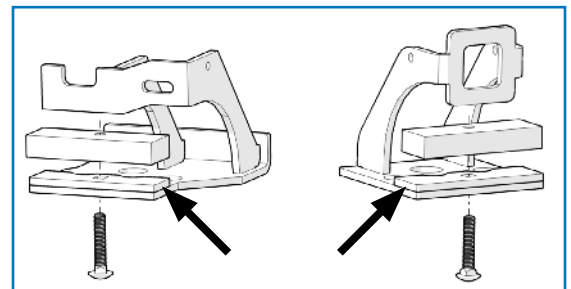

5A

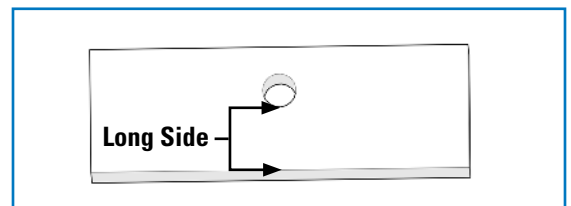

5B

7 ATTACH UPPER DRIVER BRACKET TO AIR SPRING

Assemble the driver side spring assembly (as shown in Figure 7A) by placing the upper driver bracket with spacer on the air spring and roll plate.

Align the bracket holes with the holes in the roll plate and air spring and secure using two 3/8" – 24 X 3/4" Countersunk bolts.

Torque bolts to 20 ft-lbs (27 N•m).

Attach the L-Bracket to the hole in the upper driver bracket as shown in Figure 7B. Secure using a 1/4" – 20 x 1" bolt, two 1/4" flat washers and a 1/4" nylon lock nut.

Torque bolt to 6 ft-lbs (8 N•m).

8 INSTALL PASSENGER SPRING ASSEMBLY

Install the passenger spring assembly onto the truck (as shown in Figure 8A) by inserting the previously installed carriage bolt through the hole previously occupied by the jounce bumper bolt. Secure using a 3/8" serrated flange nut and torque to 20 ft-lbs (27 N•m).

For trucks WITHOUT A FIFTH WHEEL HITCH:

Secure the upper bracket (as shown in Figure 8B on the following page) using a 1/2" – 13 X 1.25" bolt with two 1/2" X 2" OD thick flat washers, one 1/2" x 1.375" OD flat washer and one 1/2" serrated flange nut.

For trucks with a FACTORY FIFTH WHEEL HITCH:

Secure the upper bracket using the same method as above, however, replace the 1/2" X 1.375" OD flat washer that sits outside the frame with a 1/2" X 2" OD thin flat washer. The thinner washer is required in order for the serrated flange bolt to fit between the fifth wheel hitch plate and the frame.

For trucks with an AFTERMARKET FIFTH WHEEL HITCH THAT USES THE FRAME MOUNTING SLOTS:

Secure the upper bracket using the existing fifth wheel hardware previously removed in Step 3. When reinstalling hardware, add a 1/2" X 2" OD thick flat washer or 3/4" flat washer between the upper passenger bracket and the frame. The washer size needed will depend on the size of the fifth wheel bolt used.

Step continues on following page...

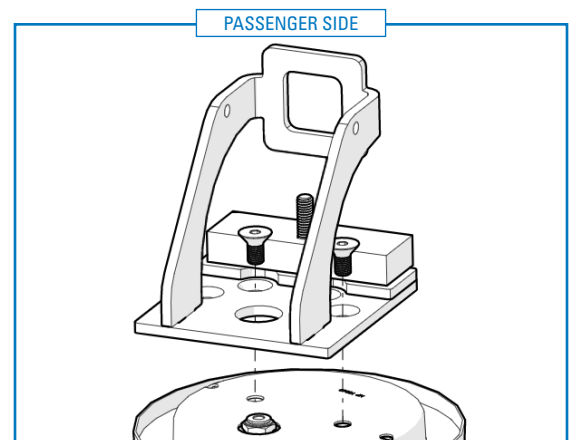

6

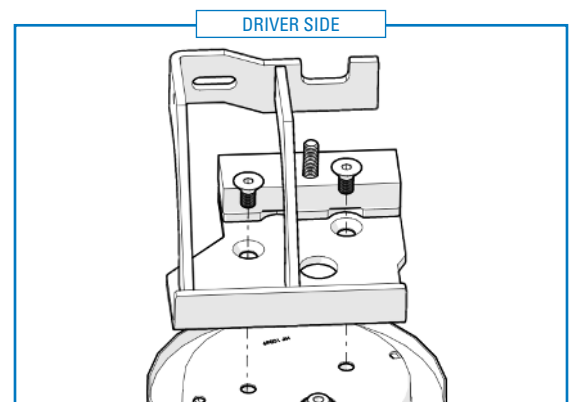

7A

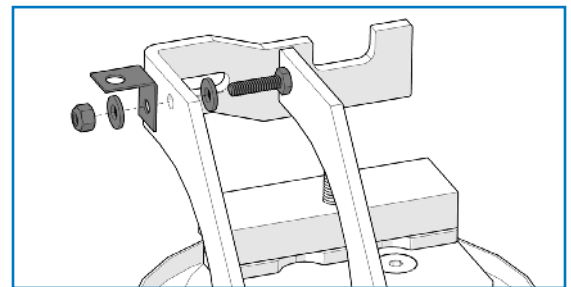

7B

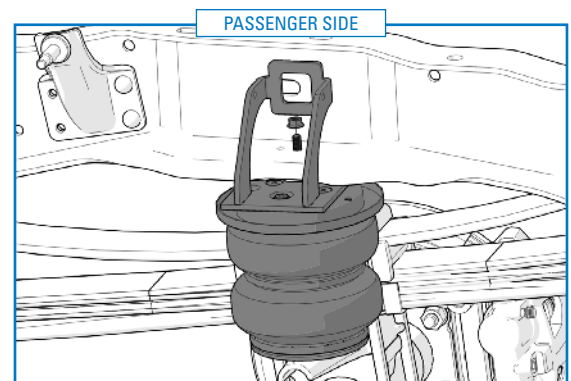

8A

For trucks with an AFTERMARKET FIFTH WHEEL HITCH THAT COVERS THE FRAME MOUNTING SLOTS:

A 1/2" hole must be drilled through the fifth wheel plate using the frame slot as a reference template.

NOTE: It may be necessary to mark the drill location and remove the spring assembly to correctly drill the hole. Use caution when drilling to not damage any wiring lines, fuel lines or other vehicle components.

Secure the upper bracket (as shown in Figure 8B) using a 1/2" – 13 X 3" bolt with two 1/2" X 2" OD thick flat washers, one 1/2" x 1.375" OD flat washer and one 1/2" serrated flange nut.

For all mounting conditions, torque bolt to 27 ft-lbs (37 N•m).

9 INSTALL DRIVER SPRING ASSEMBLY

Install the driver spring assembly onto the truck (as shown in Figure 9A) by inserting the previously installed carriage bolt through the hole previously occupied by the jounce bumper bolt.

Ensure no lines are pinched between the frame and bracket and secure using a 3/8" serrated flange nut.

Torque flange nut to 20 ft-lbs (27 N•m).

Secure the bracket to the frame (as shown in Figure 9B) using a 5/16" – 24 X 1" hex bolt, two 5/16" flat washers and a 5/16" nylon lock nut.

Torque bolt to 16 ft-lbs (22 N•m).

If the truck is equipped with an emission line, install the line clip into the hole in the L-bracket previously install in Step 7 (Figure 7B) on the upper driver bracket.

NOTE: L-bracket may need to be removed and positioned on the inner bracket surface to allow better fitment.

For trucks WITHOUT A FIFTH WHEEL HITCH:

Secure the upper bracket (as shown in Figure 9C) using a 1/2" – 13 X 1.25" bolt with two 1/2" x 1.375" OD flat washers and one 1/2" serrated flange nut.

Step continues on following page...

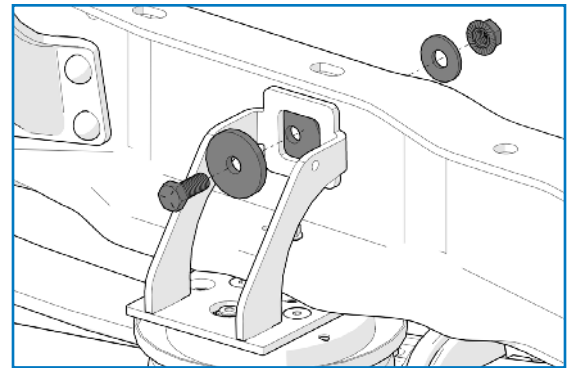

8B

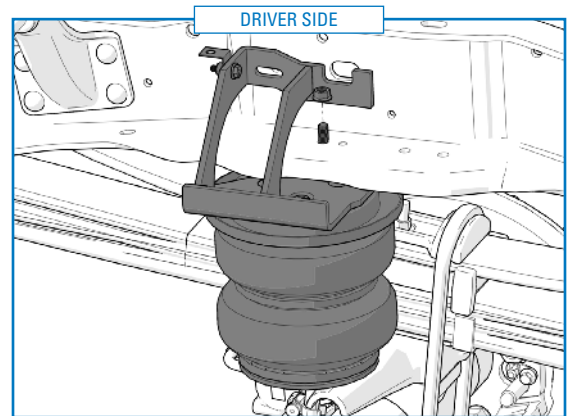

9A

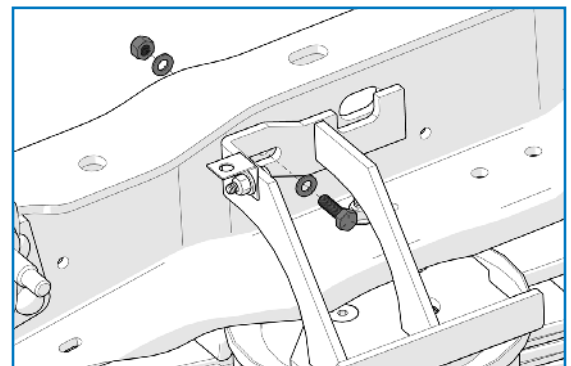

9B

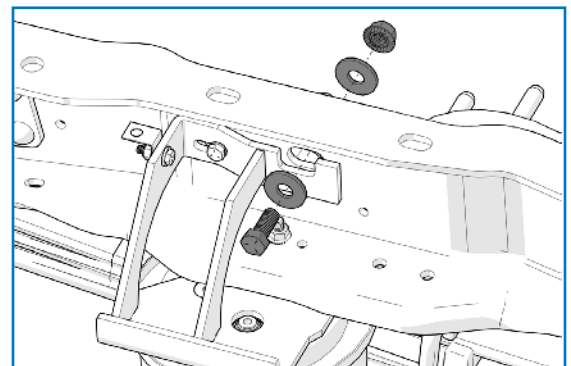

9C

For trucks with a FACTORY FIFTH WHEEL HITCH:

Secure the upper bracket using the same method as above, however, replace the 1/2" X 1.375" OD flat washer that sits outside the frame with a 1/2" X 2" OD thin flat washer. The thinner washer is required in order for the serrated flange bolt to fit between the fifth wheel hitch plate and the frame.

For trucks with an AFTERMARKET FIFTH WHEEL HITCH THAT USES THE FRAME MOUNTING SLOTS:

Secure the upper bracket using the existing fifth wheel hardware removed in Step 3.

For trucks with an AFTERMARKET FIFTH WHEEL HITCH THAT COVERS THE FRAME MOUNTING SLOTS:

A 1/2" hole must be drilled through the fifth wheel plate using the frame slot as a reference template.

NOTE: It may be necessary to mark the drill location and remove the spring assembly to correctly drill the hole. Use caution when drilling to not damage any wiring lines, fuel lines or other vehicle components.

Secure the upper bracket (as shown in Figure 9C on the previous page) using a 1/2" – 13 X 3" bolt with two 1/2" x 1.375" OD flat washers and one 1/2" serrated flange nut.

For all mounting conditions, torque bolt to 27 ft-lbs (37 N•m).

10 PRE-ASSEMBLE LOWER BRACKETS

Assemble the lower brackets (as shown in Figure 10).

Attach the lower axle bracket and lower air spring bracket using four 3/8" – 16 X 1.5" bolts, eight 3/8" flat washers and four 3/8" nylon lock nuts.

Ensure bolts are inserted from the inside or they will cause interference on trucks equipped with lift blocks.

Do not fully tighten hardware to allow for adjustability during install.

11 INSTALL LOWER BRACKET ASSEMBLY

Place lower bracket assembly in truck (as shown in Figure 11). If the truck is equipped with a lift block, ensure the air spring bracket is positioned above the block as shown.

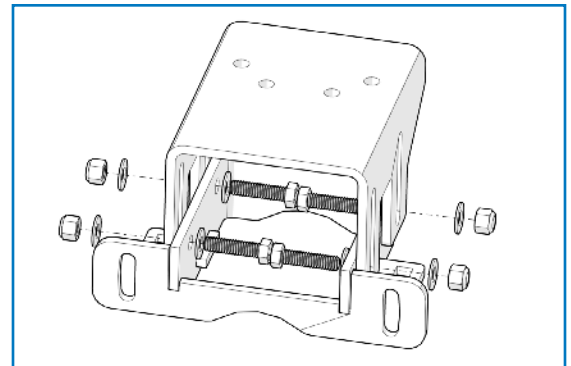

10

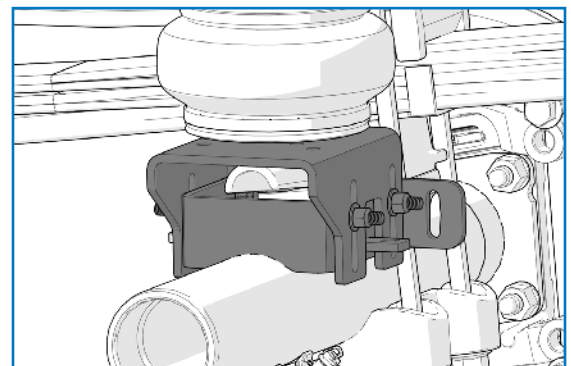

11

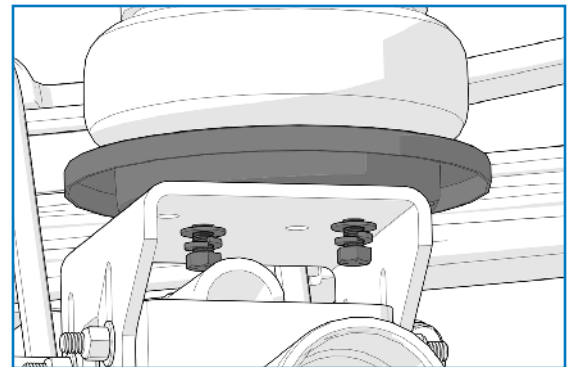

12

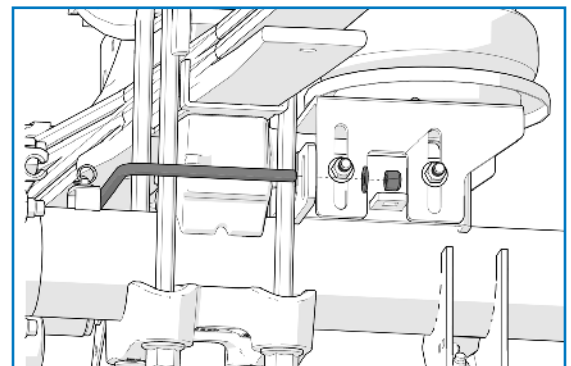

13

12 INSTALL LOWER ROLL PLATE AND SECURE AIR SPRING

Insert a roll plate between the air spring and lower bracket (as shown in Figure 12 on the previous page). Align the holes in the air spring, roll plate and air spring bracket and secure using two 3/8" – 24 X 7/8" bolts, two 3/8" lock washers and two 3/8" flat washers.

Torque bolts to 20 ft-lbs (27 N•m).

13 INSTALL LOWER BRACKET U-BOLT

Install the square U-Bolt around the leaf pack and into the axle bracket (as shown in Figure 13 on the previous page). Secure using two 3/8" flat washers and two 3/8" nylon lock nuts.

Torque nuts to 20 ft-lbs (27 N•m).

14 INSTALL AXLE CLAMP

Insert a 3/8" – 16 x 6" carriage bolt into each of the square holes on the lower axle bracket. Attach the axle strap to the carriage bolts as shown in Figure 14 using two 3/8" flat washers and two 3/8" nylon lock nuts.

Torque nuts to 20 ft-lbs (27 N•m).

15 SET AIR SPRING BRACKET HEIGHT

For vehicles WITH a lift block, lower the air spring bracket until it just touches the lift block (shown in Figure 15). Torque the four hex bolts to 38 ft-lbs (51.5 N•m) to lock this height.

For vehicles WITHOUT a lift block, lower the air spring bracket to the lowest possible position that does not result in interference with other components. Torque the four hex bolts to 38 ft-lbs (51.5 N•m)

16 ATTACH HEAT SHIELD TO MUFFLER

Bend the tabs on the heat shield (as shown with the arrows in Figure 16A) so there will be the necessary 1/2" dead space between the heat shield and the muffler when the heat shield is attached.

Attach the heat shield to the muffler (as shown with the arrow in Figure 16B) using two hose clamps. Each hose clamp holds a tab against the muffler. Make sure the heat shield is facing toward the air spring.

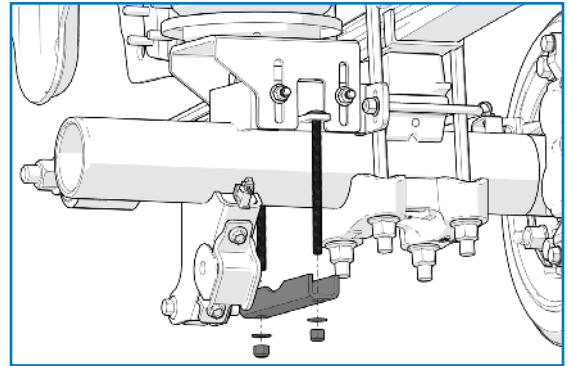

14

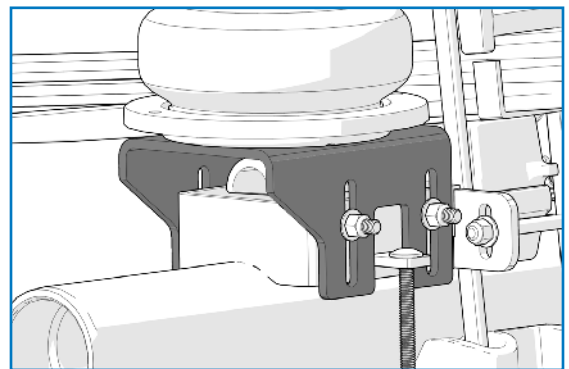

15

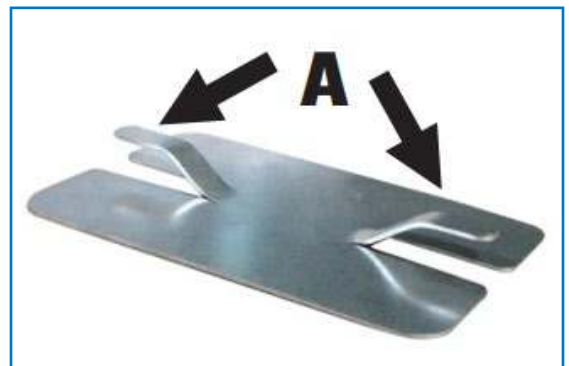

16A



16B

17 INSTALL AIR LINE

PLEASE NOTE: This kit contains push-to-connect fittings; using scissors or wire cutters to cut the nylon airline will distort the line and cause the connection to leak. THE AIRLINE MUST BE CUT OFF SQUARELY WITH THE NYLON HOSE CUTTER PROVIDED IN THIS KIT OR A SHARP UTILITY KNIFE

Provided in air spring kit are two fill valves. The most common place to install is in place of license plate fasteners. Alternatively, two 5/16" holes can be drilled in a convenient location.

Cut air line assembly into two equal lengths with hose cutter.

Install one air line, route the nylon air line to an air spring fitting and cut the hose. Moisten the end of the air line prior to inserting it into the fitting and push it in until it stops. Repeat with the other fill valve.

Secure airlines using the tie-straps, away from moving items and heat sources.

Place a 5/16" nut on the air valve. Leave enough of the inflation valve in front of the nut to extend through the hole, install a flat washer, and 5/16" nut and cap (reference Figure 17 for assembly). There should be enough valve exposed after installation—approximately 1/2"—to easily apply a pressure gauge or an air chuck.

If an in-cab inflation kit is being installed, follow the instructions provided with that kit now.

18 CHECK SYSTEM FOR LEAKS

Inflate both air springs to 90 psi and then use a mixture of dish soap and water on all air line connections to detect any air leaks. Large, expanding bubbles indicate a leak (as shown in Figure 18). Repair as necessary and retest.

Inflate air springs to a predetermined value and on following day recheck pressure. If one or both of air springs have lost pressure, an air leak is present. Leak must be repaired, and then retested until no leaks exist.

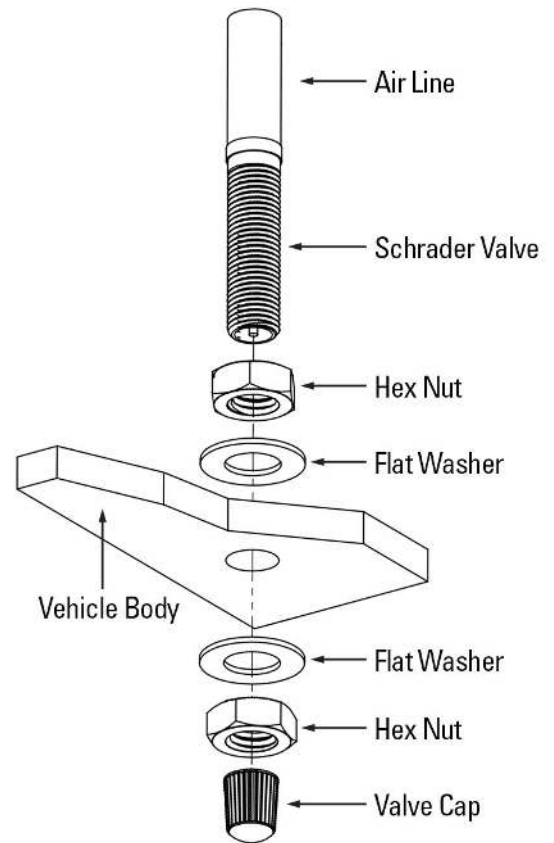

17



18

AFTER COMPLETING THE INSTALLATION

PLEASE REMEMBER:

Install wheels and torque fasteners to manufacturer's specifications.

Re-torque all fasteners after first 500 miles of driving.

For safe and proper operation, never operate the vehicle under minimum of 10 psi or over maximum of 100 psi in air springs. Staying within pressure limit will ensure maximum air spring life. Failure in doing so may result in a void warranty (see **Note** below).

NOTE: Do not exceed maximum vehicle payload. Failure to do so may result in failure of the air suspension kit and/or damage to your vehicle.

.....

Thank you again, and congratulations on the installation of the air suspension kit.

OPTIONAL ACCESSORIES

Optional dual needle air gauges are available to monitor pressure in each spring from vehicle cab, as well as a full line of air compressors, air tanks, and solenoids built to work with and control your air spring system.

OPERATING YOUR VEHICLE WITH AIR SUSPENSION

Air springs have minimum and maximum pressure requirements. Never operate your vehicle with less than 10 psi in air spring and never inflate air springs over 100 psi. Damage to air springs will result.

Check air pressure in air springs daily for first couple of days to ensure a leak has not developed. Air springs are designed to maintain the vehicles stock ride height with a load. Do not use the air springs as a means to lift vehicle with no load. This will result in a harsh ride.

SERVICING YOUR VEHICLE WITH AIR SUSPENSION

When lifting the vehicle with a floor jack or hoist on the frame, never allow the air spring to limit the travel of the axle. Try to always jack the vehicle on the axle. Suspending the axle with the air spring limiting the axle travel will damage the air spring and void the air spring warranty.

WARRANTY

To be eligible for warranty, the owner must submit their warranty card or register online within 30 days of the purchase date.

NOTE: The owner's warranty will be void if air springs are run with less than the minimum of 10 psi.

.....