



www.photonicuniverse.com

+44 (0) 203 150 11 11

12V to 12V DC-DC Battery Charger

DC1212-30S and DC1212-45S series

INSTRUCTION MANUAL

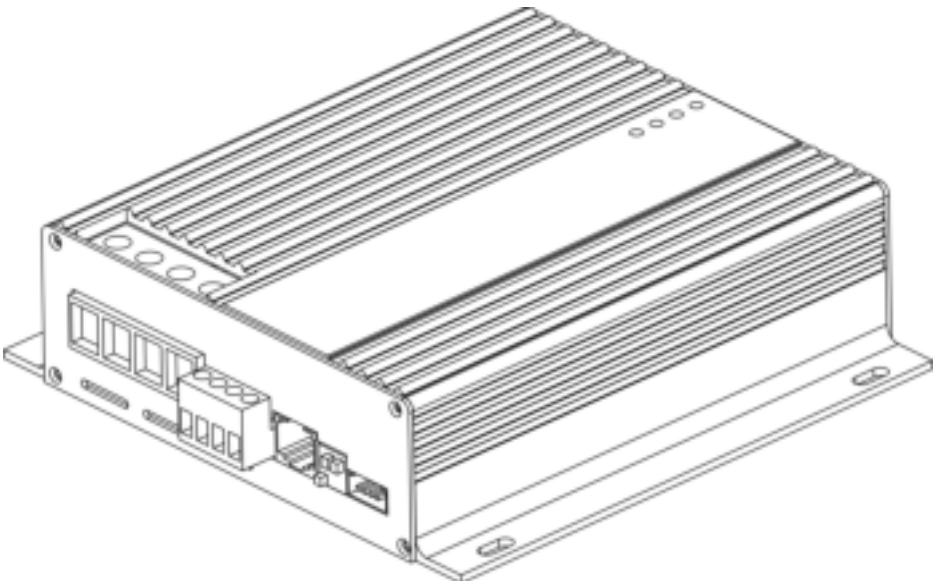

Overview

This Photonic Universe DC-DC battery charger is fully automatic and ideal for leisure vehicles, commercial and special purpose vehicles, boats, and any other systems with multiple 12V batteries or power sources. The charger operates using an adjustable three-stage charging programme and is suitable for lead acid, AGM, GEL, LiFePO4 and Lithium-ion (NCM) batteries. The product features high frequency switching and buck-boost power conversion technology for reliable, consistent performance.

The D+ terminal of the charger activates the charging function automatically when the vehicle alternator starts, avoiding battery discharge when it stops. A range of protection functions enables the charger to automatically disconnect the target (OUT) battery from the source (IN) battery under extreme conditions, such as in case of overheating, overvoltage, short circuits, and over-currents.

The charger includes ports for a remote meter or a Bluetooth dongle (both sold separately), allowing data to be viewed on an LCD display or through a mobile phone app when connected.

An optional external temperature sensor (sold separately) can be connected to the charger for automatic adjustment of the charging voltages depending on the ambient temperature (lead-acid batteries only), keeping the charging programme to optimal voltages at very low or high temperatures.

The charger also features an automatic wake-up function for lithium batteries. When the Battery Management System (BMS) of a lithium battery goes into the protection mode, the charger can automatically activate the BMS and continue charging the lithium battery.

The charger is compact, light-weight and convenient to install and operate.

Installation

Install the battery charger as close to the target (OUT) battery as possible and keep the surrounding area clean, tidy, and well ventilated. This space should be moisture-proof, water-proof, and corrosion proof. Leave at least 10 cm of space around the charger to allow for proper airflow.

The recommended cable cross-section for “+” and “-” power cables is 1 mm² cross-section for every 3A of maximum charging current. In any case **do not use cables with lower current rating than the maximum charging current of the charger**. In addition, to minimise the power loss and voltage drop, please do not exceed the maximum cable lengths referenced below:

Cable cross-section	Charger model	Maximum cable length from “+” and “-” charger terminals to	
		Source Battery	Target Battery
6 mm ²	DC1212-30S	Up to 3.5m	Up to 2m
10 mm ²	DC1212-30S / DC1212-45S	Up to 6m	Up to 3m
16 mm ²	DC1212-30S / DC1212-45S	Up to 10m	Up to 5m

Note: Please select the target battery type (lead-acid, GEL, AGM, LiFePO4, Lithium-ion (NCM)) before connecting and using the charger. Refer to the DIP switches section below for details.

Connection diagram

- Use as short cables as possible, especially between the charger and the target battery
- The fuses need to be located within 15cm from the terminals of the batteries. Choose the rating of the fuses according to the maximum charging current.
- Ensure the positive and negative poles are not reversed or short-circuited
- Always connect the cables to the charger terminals first before connecting them to the battery terminals, to ensure you are not working with live cables

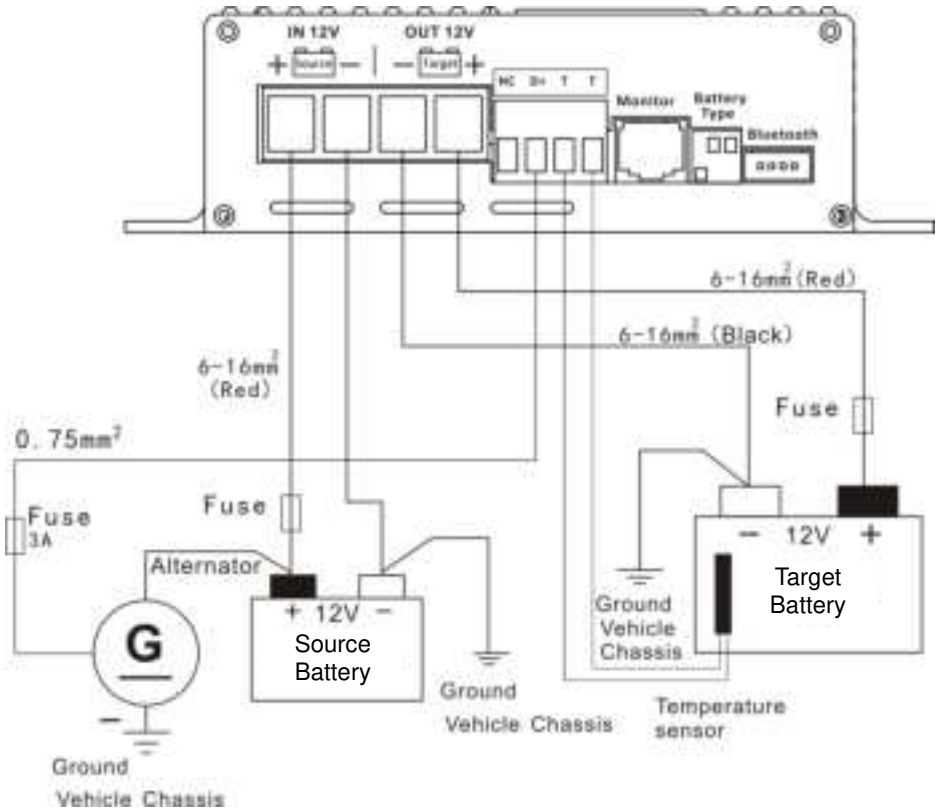

IMPORTANT! The charger requires a D+ signal to operate. If there is no signal applied to the D+ terminal, the charger **will not turn on**. If your system does not have a D+ signal, the D+ terminal can be wired directly to the positive terminal (12V +) of the source battery to turn the charger ON.

Green terminals

The charger features a pluggable terminal block of 4 green terminals. In a place with limited installation space, the terminal block can be unplugged for connection or disconnection of the wires and then re-inserted. The size of the cable for this terminal block is 0.75mm² and the stripping length is about 6mm. Description of the terminal contacts is provided below.

“TT”: these are the terminals for connecting an optional temperature sensor for measuring the temperature of the target battery.

If you install a temperature sensor in your system, please ensure that it is not affected by any heat source. Fix it on the case of the target battery or connect it to the negative terminal of the battery.

A temperature sensor is highly recommended for lead acid batteries in case if the ambient temperatures vary substantially from the baseline temperature of 25°C. The sensor performs two main functions:

- Charging voltage adjustment. The charging voltage for the target battery is compensated up or down depending on the ambient temperature to regulate the speed of chemical reaction inside the battery. The voltage will increase in the winter and decrease in the summer at the rate 18mV for each degree Celsius away from the reference temperature 25 °C.
- Battery protection. When the temperature is lower than -20°C or higher than 50°C, the charger limits the maximum charging current to 10A.

The charger can identify whether the temperature sensor is connected or not, or if it's damaged, short-circuited, or when an abnormal temperature is measured. In such case, the charger will automatically set the charging programme to the default temperature 25°C.

Note: there is no temperature compensation for lithium batteries.

“D+” : this is the terminal for connecting a “D+” signal (12V +) from the alternator, if the charger is used in a vehicle and the source battery (IN) is the vehicle's starter battery. This terminal controls the ON / OFF function of the charger. The charger will only operate at times when the alternator sends a “D+” signal to this “D+” terminal (when the alternator is working). The input voltage range for this signal is 8V – 16V.





Alternatively, another connection option in a vehicle where the starter battery is used as a source battery, is to connect “D+” terminal of the charger to the 12V + signal from the ignition of the vehicle. In such case, if the ignition is ON, the charger will be ON and if the ignition is OFF, the charger will be OFF.

In a system without an alternator, this “D+” terminal should be connected to the positive 12V + terminal of the source battery to enable the charger to turn on. **The charger will not operate if “D+” terminal is not connected.** It is also possible to fit a suitable ON/OFF switch between the “D+” terminal and the positive 12V + terminal of the source battery to control the ON / OFF function of the charger.

“NC”: this is reserved as a spare terminal with no function and no need to connect anything.

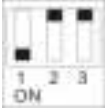
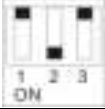
Batteries

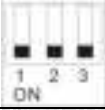
Before you connect and use the charger, please set the correct battery type for the target battery from the range of 5 options below.

DIP switches	Battery type	Boost charging voltage
 1: ON 2: OFF 3: OFF	GEL	14.3V
 1: OFF 2: ON 3: OFF	Lead-acid	14.4V
 1: OFF 2: OFF 3: ON	AGM	14.7V
 1: ON 2: ON 3: ON	LiFePO4	14.4V
 1: OFF 2: OFF 3: OFF	Lithium-ion (NCM)	12.6V

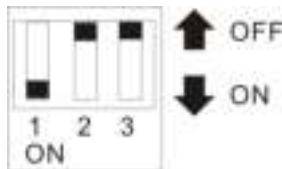

Note: if the DIP switches are set to a wrong combination which does not correspond to any of the 5 battery types above, all LED indicators of the charger will flash once per second.

Note: before charging, ensure the battery type is preset while the charger is off. Any adjustments made to the settings while charging will only take effect once the charger is turned off and then back on.

Charging instructions

Lithium battery charging: when charging a lithium battery, ensure it has a Battery Management System (BMS). Charging lithium batteries without BMS is not permitted. Keep the battery temperature above 0°C when charging.

Lithium battery activation program: when the connected target battery is lithium and its BMS is in a low voltage protection mode (no voltage output), the charger can automatically activate

the lithium battery to recharge if both of the following conditions are met:

- 1) The source battery voltage is > 11.5V
- 2) The “D+” signal voltage range is 10V - 16V

Charging paralleled batteries: it is possible to charge two or more paralleled batteries if they have the same voltage, type, capacity, age, with the same cross-section of cables, and they have been used together as a single battery bank.

Reduced power: when the source battery voltage is low, the charger will automatically reduce the charging current, and if the voltage increases (to the “Recovery voltage”), will increase the current again (“Recovery charging current”) as per the table below:

Source battery voltage	Reduced charging current		Recovery voltage	Recovery charging current	
	DC1212-30S	DC1212-45S		DC1212-30S	DC1212-45S
> 12.6V	30A	45A	-	-	-
< 12.35V	27A	39A	> 12.5V	30A	45A
< 12.2V	24A	33A	> 12.45V	27A	39A
< 12.05V	20.5A	27A	> 12.35V	24A	33A
< 11.9V	17A	21A	> 12.25V	20.5A	27A
< 11.7V	13.5A	15A	> 12.1V	17A	21A
< 11.5V	10A	10A	> 12.0V	13.5A	15A
< 11.2V	Stops charging		> 12.6V	30A	45A

LED indicators

Power-on self-check: all the indicators are on for 1 second, and then turned off.

LED	LED status	Charger status
Source Battery (yellow)	OFF	No D+ signal, no charging
	Slow flashing (1 flash / 5 seconds)	Source battery voltage is < 11.2V and the charging stopped. The voltage needs to return to 12.6V to activate the charging again. The LED will keep flashing during this period.
	Fast flashing (1 flash / 1 second)	Source battery voltage is higher than 16V
	ON	Source battery voltage is normal
Charge (green)	OFF	No charging
	Slow flashing (1 flash / 2 seconds)	The battery temperature is too high or the lithium battery is below -20°C
	Fast flashing (1 flash / 1 second)	Over temperature detected inside the charger
	ON	Charging
Battery Full (green)	OFF	No charging
	Slow flashing (1 flash / 5 seconds)	Bulk / boost (constant current) charging stage
	Fast flashing (1 flash / 1 second)	Absorption (constant voltage) charging stage
	ON	Battery full

Target Battery (red)	Slow flashing (1 flash / 5 seconds)	Target battery voltage is normal
	Fast flashing (1 flash / 1 second)	Target battery overvoltage
	ON	Target battery low voltage
All LEDs flashing	Battery selection error. Turn off the charger and adjust DIP switches to match one of the existing battery types.	

Charging process

Boost (constant current) charging stage: during this stage, the charger will charge the target battery with the maximum rated current until the target battery voltage reaches the boost voltage.

Absorption (constant voltage) charging stage: when the target battery voltage reaches the boost voltage, the charger will enter the absorption (constant voltage) charging stage. During this stage the charger will maintain the boost voltage and the charging current will gradually reduce. This stage will last for 1 or 2 hours depending on the battery type.

Float charging stage: after the absorption stage, the charger will reduce the charging voltage to the float voltage and continue charging the target battery with a low current to keep it full.

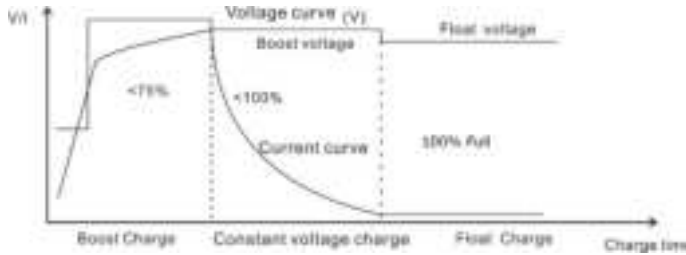

Equalisation: for selected battery types, the charger will perform equalisation charging by timer once a month with a higher charging voltage, in order to raise all battery cells to the same level. Equalisation charging will last for 2 hours. Please refer to the battery types table for details.

Note: if the target battery voltage is > 12.6V at the start of the charging process, the charger will not perform the absorption (constant voltage) stage and will instead charge to the boost voltage level and then go straight to the float charging stage.

Protection functions

Protection	Description
Target battery overvoltage	If the target battery voltage is > overvoltage protection voltage, the charging will stop. If the target battery voltage is > boost voltage value + 0.2V for 10 seconds, the charging will stop. Buzzer alarm: beeps once repeatedly for 1 minute
Target battery low voltage	If the target battery voltage is < low voltage alarm voltage, the buzzer alarm will beep twice repeatedly for 1 minute.

Source battery low voltage	If the source battery voltage is 11.5V-11.2V, the charging current is reduced to 10A. If the source battery voltage is < 11.2V, the charging will stop.
Overpower	The maximum charging current of the target battery is limited to 30A for DC1212-30S charger and 45A for DC1212-45S charger.
Battery reverse polarity	If the target or the source battery is connected with a reverse polarity, it will blow the fuse inside the charger and may also cause hardware damage to the charger. Please contact the supplier of the charger with all the details, including which battery was connected with a reversed polarity.
Overheating (internal temperature)	If the internal temperature is higher than 85°C, the charging will stop until the temperature drops to 60°C. When the temperature is > 80°C but less than 85°C, the maximum charging current is reduced to 25A for DC1212-30S charger and 37A for DC1212-45S charger. When the temperature drops to 65°C, the charging current returns to 30A/45A. Buzzer alarm: two consecutive beeps followed by a single beep repeatedly for 1 minute.

Battery type parameters

Battery type	GEL	Lead-acid	AGM	LiFePO4	Lithium-ion (NCM)
Boost charging voltage	14.3V	14.4V	14.7V	14.4V	12.6V
Float charging voltage	13.8V	13.5V	13.5V	13.8V	12.5V
Equalisation charging voltage	-	14.6V	14.8V	-	-
High-voltage protection	15.5V	15.5V	15.5V	15.5V	13.5V
Low-voltage alarm	11.0V	11.0V	11.0V	11.0V	9.3V
Absorption (constant voltage) charging time	2h	2h	2h	1h	1h
Safety charging voltage at < -20°C or > 50°C	12.8V	12.8V	12.8V	13.0V	12.0V
High voltage recovery voltage	13.7V	13.7V	13.7V	14.8V	12.8V
Boost charge recovery voltage *	13.2V	13.2V	13.2V	13.2V	12.0V

* When the charger is in the Float charging stage and the target battery voltage drops to this level, the charger re-enters the Boost charging stage with the maximum charging current.

Specifications

Model	DC1212-30S	DC1212-45S
Target battery		
Gel, Lead-Acid, AGM rated voltage	12V	
LiFePO4 rated voltage	12.8V	
Lithium-ion(NCM) rated voltage	11.1V	

Battery capacity	45Ah - 280Ah	80Ah - 400Ah
Battery operating voltage range	8-16V	
Source battery		
Battery voltage	12V	
Minimum recommended capacity	60Ah	
Battery operating voltage range	10.5V - 16V	
Maximum charging power	390W	585W
Maximum charging current of target battery	30A	45A
Effective D+ signal voltage range	8V - 16V	
Temperature compensation	-3mV/°C/2V	
Target battery temperature sensor input "T T"	Yes	
Standby current	17mA	
Weight	0.46kg	0.72kg
Dimensions	147x142x41mm	147x156x41mm
Operating temperature	From -20°C to 50°C	

CB and CBR circuit breakers (optional)

Optional surface mounted (CB series) and recess mounted (CBR series) DC circuit breakers can be purchased from Photonic Universe and used instead of fuses when connecting this charger to the source and target batteries. The range of circuit breakers includes 30A, 40A, 50A and 60A circuit breakers rated for 12V / 24V / 48V systems with product codes **CB30 – CB60, CBR40**.



Temperature sensor DCDC-TS (optional)

This charger is compatible with an optional temperature sensor **DCDC-TS**. The sensor will measure the external temperature of the target battery and provide the real time temperature readings to the charger for voltage adjustment and protection (see the above section about "T T" terminals for reference). The voltage adjustment applied for lead acid batteries is 18mV/°C. If the temperature sensor is not connected, the charger will charge the target battery based on the default temperature settings for 25°C.



Remote meter ACDC-RM (optional)

An optional remote LCD meter **ACDC-RM** can be connected to the charger to display charging parameters such as real time battery voltage, charging current, charging Ah, charging Wh and any fault information.



Bluetooth dongle ACDC-BT (optional)

Using an optional Bluetooth dongle **ACDC-BT**, the charger can be connected to a mobile phone app to allow the user to monitor charging parameters such as real time battery voltage, charging current, charging Ah, charging Wh and any fault information.



To setup the Bluetooth dongle and connection to the mobile phone, please install the correct and up-to-date version of the app using the name, links or QR codes for the app provided in a separate user manual for the Bluetooth dongle.

If you would like to purchase any of these optional extras, please visit our online shop

www.PhotonicUniverse.com

or call 0203 150 1111 (international +44 203 150 1111) for a phone order.

Photonic Universe Ltd

E-mail: info@photonicuniverse.com

Web: www.photonicuniverse.com

Tel.: +44 (0) 203 150 11 11

Fax: +44 (0) 203 150 12 12