

Owner's Manual & Safety Instructions

Save This Manual Keep this manual for the safety warnings and precautions, assembly, operating, inspection, maintenance and cleaning procedures. Write the product's serial number in the back of the manual near the assembly diagram (or month and year of purchase if product has no number). Keep this manual and the receipt in a safe and dry place for future reference.

22d

PITTSBURGH®

12V LIGHT-DUTY PORTABLE INFLATOR



Item	63152
Electrical Rating	12VDC
Overall Dimensions	5-1/2" L x 2-7/8" W x 4-7/8" H

Visit our website at: <http://www.harborfreight.com>
Email our technical support at: productsupport@harborfreight.com

When unpacking, make sure that the product is intact and undamaged. If any parts are missing or broken, please call 1-888-866-5797 as soon as possible.

Copyright© 2022 by Harbor Freight Tools®. All rights reserved.
No portion of this manual or any artwork contained herein may be reproduced in any shape or form without the express written consent of Harbor Freight Tools. Diagrams within this manual may not be drawn proportionally. Due to continuing improvements, actual product may differ slightly from the product described herein. Tools required for assembly and service may not be included.

⚠WARNING

Read this material before using this product.
Failure to do so can result in serious injury.
SAVE THIS MANUAL.

Specifications

Electrical Rating	12VDC
Overall Dimensions	5-1/2" L x 2-7/8" W x 4-7/8" H

PITTSBURGH[®]

IMPORTANT SAFETY INFORMATION



WARNING Read all safety warnings and instructions.

Failure to follow the warnings and instructions may result in electric shock, fire and/or serious injury.
Save all warnings and instructions for future reference.

The warnings, precautions, and instructions discussed in this instruction manual cannot cover all possible conditions and situations that may occur. It must be understood by the operator that common sense and caution are factors which cannot be built into this product, but must be supplied by the operator.

Use Precautions

1. **Do not use on automotive tires.**
2. This product is not a toy. Do not allow children to play with or near this item.
3. Use as intended only.
4. Inspect before every use; do not use if parts are loose or damaged.
5. Disconnect cigarette lighter plug from receptacle when not in use.
6. **Avoid unintentional starting.** Be sure the Thumbwheel Switch is in the Off position when not in use and before plugging in.
7. **Store idle equipment.** When not in use, tools must be stored in a dry location to inhibit rust. Always lock up tools and keep out of reach of children.
8. **Do not overreach.** Keep proper footing and balance at all times. Do not reach over or across running machines or air hoses.
9. Maintain product labels and nameplates. These carry important safety information. If unreadable or missing, contact Harbor Freight Tools for a replacement.

PITTSBURGH[®]

Operating Instructions



Read the **ENTIRE IMPORTANT SAFETY INFORMATION** section at the beginning of this document including all text under subheadings therein before set up or use of this product.

WARNING! TO PREVENT SERIOUS INJURY:

This Inflator is not for inflating automotive tires!

1. Remove the Cigarette Plug (14) from the recessed holder on the unit (see Figure A).
2. Assure that the Thumbwheel Switch is turned to the "Off" position.
3. Situate the Inflator outside of the car.
4. Plug the Cigarette Plug into the 12 Volt receptacle in the car.

WARNING! TO PREVENT SERIOUS INJURY: Due

to the risk of carbon monoxide poisoning, do not run the vehicle's engine within an enclosed area.

5. Turn on the Inflator by sliding the Thumbwheel Switch to the "on" position.

NOTICE: Do not allow the Inflator to run for more than 10 minutes (continuously) at a time. After 10 minutes, allow it to cool for 30 minutes, and then you may resume inflation. Failure to do so may cause the unit to overheat and burn out.

Note: When attaching the Air Outlet (16) to a tire or adapter, lift the Valve Lock (17). Attach the hose to the tire or adapter, and then press down the Valve Lock to seal the connection. To detach the hose from the tire or adapter, lift the Valve Lock and remove.

6. The Air Outlet has a universal tire adapter, so no adapter is needed to fill a standard tire.
7. To fill a standard athletic ball, thread on the Sports Needle accessory.
8. When using the unit as an air blower, thread on the appropriate sized adapter (two included).

CAUTION! To avoid burns, do not touch the Inflator when it is in operation. The Inflator will become very hot.

9. Attach the Inflator to the item you wish you inflate.
10. When you are finished, turn Off the Inflator by turning the Thumbwheel Switch to the "Off" position. Lift up on the Valve Lock and detach the unit. Store the Cord/Cigarette Plug in the recessed holder.

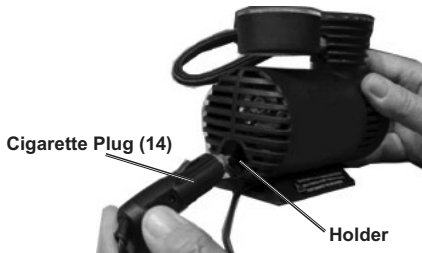

Figure A

EXPLOSION DANGER!
TO PREVENT
SERIOUS INJURY:

Before inflating, check the manufacturer's recommended air pressure. Do not exceed that pressure. Over inflation may result in an explosion.

PITTSBURGH[®]



Procedures not specifically explained in this manual must be performed only by a qualified technician.

⚠ WARNING

TO PREVENT SERIOUS INJURY FROM ACCIDENTAL OPERATION:

Turn the Thumbwheel switch “OFF” and disconnect the Power Cord/Cigarette Plug before performing any inspection, maintenance, or cleaning procedures.

TO PREVENT SERIOUS INJURY FROM INFLATOR FAILURE:

Do not use damaged equipment. If abnormal noise or vibration occurs, have the problem corrected before further use.

1. **BEFORE EACH USE**, inspect the general condition of the Inflator. Check for:
 - loose hardware,
 - misalignment or binding of parts,
 - cracked or broken parts,
 - damaged electrical wiring, and
 - any other condition that may affect its safe operation.
2. **AFTER USE**, wipe external surfaces of the Inflator with a clean cloth.
3. Check that the Cigarette Plug is clean of dirt, grease, or debris.
4. Make sure the universal outlet adapter is clean of dirt, grease, or debris.
5. When servicing, use only identical replacement parts. Use of any other parts will void the warranty. Only use accessories intended for use with this tool. Approved accessories are available from Harbor Freight Tools.
6. For your safety, maintenance should be performed regularly by a qualified technician.

Parts List and Diagram

Part	Description	Qty
1	Hull	1
2	Mat	1
3	Screw	5
4	Gauge	1
5	Cylinder Head	1
6	Long Screw	2
7	O Ring	1
8	Cylinder Housing	1
9	Mat	1
10	Piston Ring	1
11	Piston Head	1
12	Spindle	1
13	Connecting Rod	1
14	Cigarette Plug	1

Part	Description	Qty
15	Switch	1
16	Air Outlet	1
17	Valve Lock	1
18	Rubber Hose	1
19	Screw	1
20	Motor	1
21	Retainer	1
22	Small Gear	1
23	Large Gear	1
24	Support	1
25	Eccentric	1
26	Hull	1
27	Temperature Control	1

PLEASE READ THE FOLLOWING CAREFULLY

THE MANUFACTURER AND/OR DISTRIBUTOR HAS PROVIDED THE PARTS LIST AND ASSEMBLY DIAGRAM IN THIS DOCUMENT AS A REFERENCE TOOL ONLY. NEITHER THE MANUFACTURER OR DISTRIBUTOR MAKES ANY REPRESENTATION OR WARRANTY OF ANY KIND TO THE BUYER THAT HE OR SHE IS QUALIFIED TO MAKE ANY REPAIRS TO THE PRODUCT, OR THAT HE OR SHE IS QUALIFIED TO REPLACE ANY PARTS OF THE PRODUCT. IN FACT, THE MANUFACTURER AND/OR DISTRIBUTOR EXPRESSLY STATES THAT ALL REPAIRS AND PARTS REPLACEMENTS SHOULD BE UNDERTAKEN BY CERTIFIED AND LICENSED TECHNICIANS, AND NOT BY THE BUYER. THE BUYER ASSUMES ALL RISK AND LIABILITY ARISING OUT OF HIS OR HER REPAIRS TO THE ORIGINAL PRODUCT OR REPLACEMENT PARTS THERETO, OR ARISING OUT OF HIS OR HER INSTALLATION OF REPLACEMENT PARTS THERETO.

Assembly Diagram

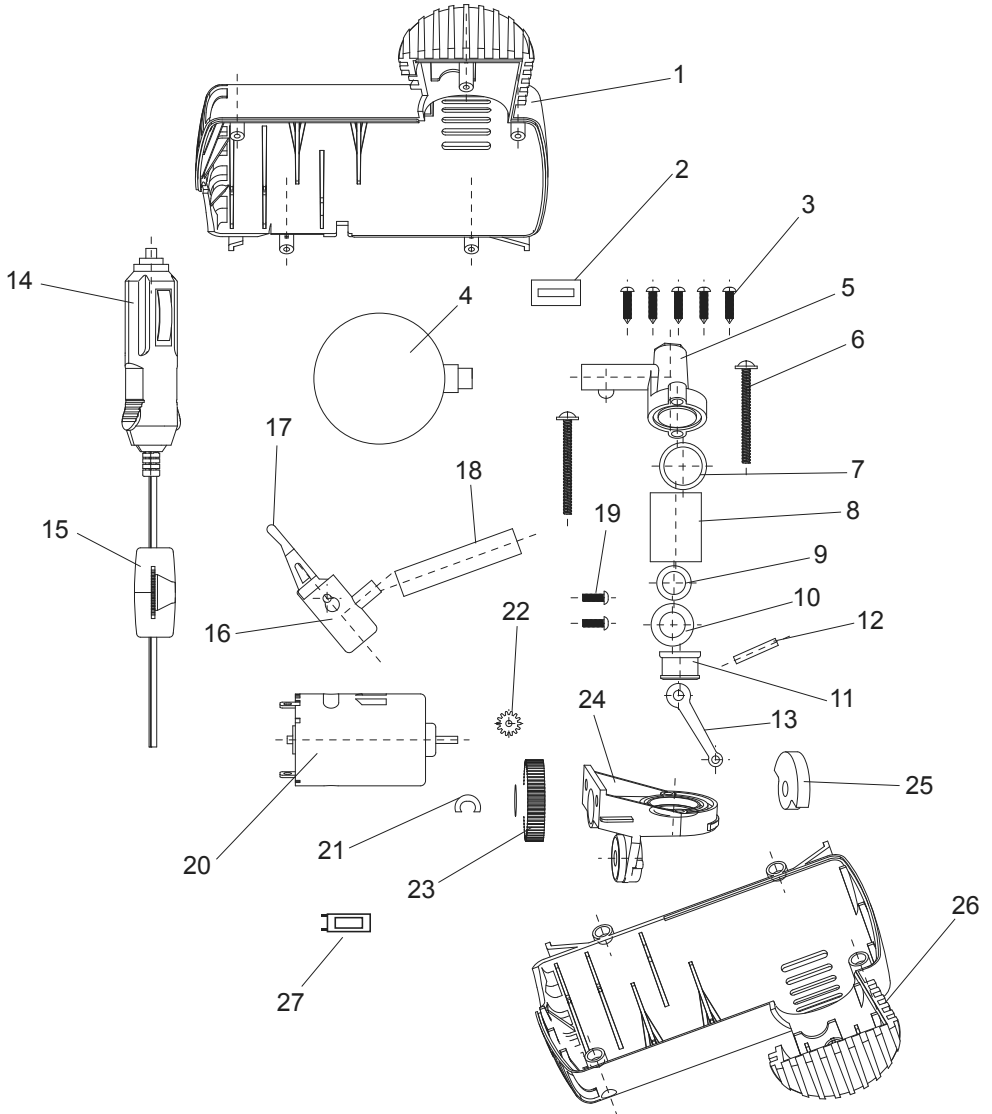

Record Serial Number Here:

Note: If product has no serial number, record month and year of purchase instead.

Note: Some parts are listed and shown for illustration purposes only, and are not available individually as replacement parts. Specify UPC 193175486615 when ordering parts.

Limited 90 Day Warranty

Harbor Freight Tools Co. makes every effort to assure that its products meet high quality and durability standards, and warrants to the original purchaser that this product is free from defects in materials and workmanship for the period of 90 days from the date of purchase. This warranty does not apply to damage due directly or indirectly, to misuse, abuse, negligence or accidents, repairs or alterations outside our facilities, criminal activity, improper installation, normal wear and tear, or to lack of maintenance. We shall in no event be liable for death, injuries to persons or property, or for incidental, contingent, special or consequential damages arising from the use of our product. Some states do not allow the exclusion or limitation of incidental or consequential damages, so the above limitation of exclusion may not apply to you. THIS WARRANTY IS EXPRESSLY IN LIEU OF ALL OTHER WARRANTIES, EXPRESS OR IMPLIED, INCLUDING THE WARRANTIES OF MERCHANTABILITY AND FITNESS.

To take advantage of this warranty, the product or part must be returned to us with transportation charges prepaid. Proof of purchase date and an explanation of the complaint must accompany the merchandise. If our inspection verifies the defect, we will either repair or replace the product at our election or we may elect to refund the purchase price if we cannot readily and quickly provide you with a replacement. We will return repaired products at our expense, but if we determine there is no defect, or that the defect resulted from causes not within the scope of our warranty, then you must bear the cost of returning the product.

This warranty gives you specific legal rights and you may also have other rights which vary from state to state.

PITTSBURGH[®]

26677 Agoura Road • Calabasas, CA 91302 • 1-888-866-5797