

Owner's Manual & Safety Instructions

Save This Manual Keep this manual for the safety warnings and precautions, assembly, operating, inspection, maintenance and cleaning procedures. Write the product's serial number in the back of the manual near the assembly diagram (or month and year of purchase if product has no number). Keep this manual and the receipt in a safe and dry place for future reference.

22d

PITTSBURGH®

1000 LB. ENGINE STAND

Item	59201
Weight Capacity	1,000 lb.
Assembled Dimensions	35-1/2" L x 29-1/2" W x 34-3/8" H
Face Plate	10" L x 6" W x 5/8" Thick
Wheel Diameter	3" (x2), 3-1/2" (x2)

Conforms with ASME PASE 2019



Visit our website at: <http://www.harborfreight.com>
Email our technical support at: productsupport@harborfreight.com

When unpacking, make sure that the product is intact and undamaged. If any parts are missing or broken, please call 1-888-866-5797 as soon as possible.

Copyright© 2021 by Harbor Freight Tools®. All rights reserved.
No portion of this manual or any artwork contained herein may be reproduced in any shape or form without the express written consent of Harbor Freight Tools. Diagrams within this manual may not be drawn proportionally. Due to continuing improvements, actual product may differ slightly from the product described herein. Tools required for assembly and service may not be included.

⚠ WARNING

Read this material before using this product.
Failure to do so can result in serious injury.
SAVE THIS MANUAL.

IMPORTANT SAFETY INFORMATION

Assembly Precautions

1. Assemble only according to these instructions. Improper assembly can create hazards.
2. Wear ANSI-approved safety goggles and heavy-duty work gloves during assembly.
3. Keep assembly area clean and well lit.
4. Keep bystanders out of the area during assembly.
5. Do not assemble when tired or when under the influence of drugs or medication.
6. Weight capacity and other product capabilities apply to properly and completely assembled product only.

Use Precautions

Failure to heed these instructions may result in personal injury and/or property damage:

1. Study, understand, and follow all instructions before operating this device.
2. Do not exceed rated capacity.
Be aware of dynamic loading!
Sudden load movement may briefly create excess load causing product failure.
3. Use Stand only on a flat, level, hard and smooth surface capable of supporting the weight of Stand and engine.
4. Lock mounting plate rotating mechanism before applying a load.
5. Assure load is centered and secured to mounting attachments.
6. Hold Handle while removing the Pin.
7. Wear ANSI-approved safety goggles and heavy-duty work gloves during use.
8. Do not use for aircraft purposes.
9. Inspect before every use; do not use if parts loose or damaged.
10. This product is not a toy. Do not allow children to play with or near this item.
11. Use as intended only.
12. Maintain product labels and nameplates. These carry important safety information. If unreadable or missing, contact Harbor Freight Tools for a replacement.

Assembly Instructions



Read the **ENTIRE IMPORTANT SAFETY INFORMATION** section at the beginning of this document including all text under subheadings therein before set up or use of this product.

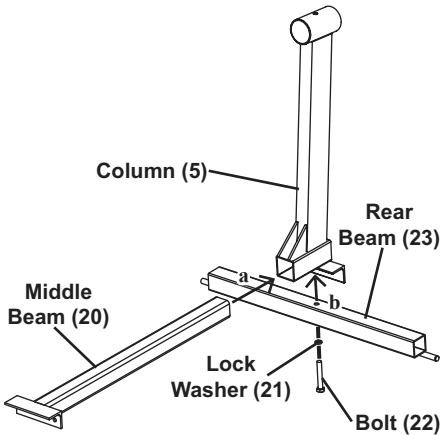

Figure A: Attaching Column to Rear and Middle Beams

1. To attach the Column to the Rear and Middle Beams:
 - a. Insert Middle Beam (20) into the receiver at the bottom of the Column (5).
 - b. Place the Rear Beam (23) against the Column. Align the holes in all three parts and secure with a Bolt (22) and Lock Washer (21).

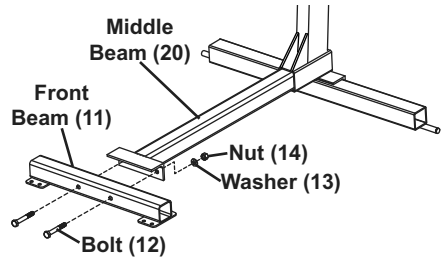

Figure B: Attach Front Beam

2. Use Bolts (12), Washers (13), and Nuts (14) to attach the Front Beam (11) to the Middle Beam (20), with the brackets on the bottom as shown.

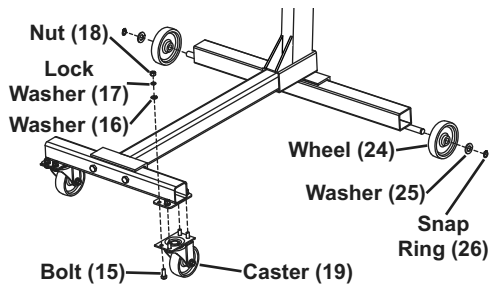

Figure C: Attach Wheels and Casters

3. Attach Casters (19) to the Front Beam (11) using Bolts (15), Washers (16), Lock Washers (17), and Nuts (18).
4. Slide a Wheel (24) onto each axle at end of Rear Beam (23). Then slide on a Washer (25) and secure with a Snap Ring (26).

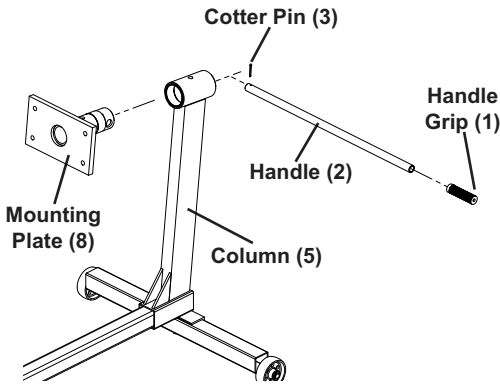

Figure D: Attach Mounting Plate and Handle

5. Grease the Mounting Plate (8) shaft using chasis grease (sold separately).
6. Insert Mounting Plate shaft into the top of the Column (5). Insert the Handle (2) through the Mounting Plate (8) and secure with the Cotter Pin (3).

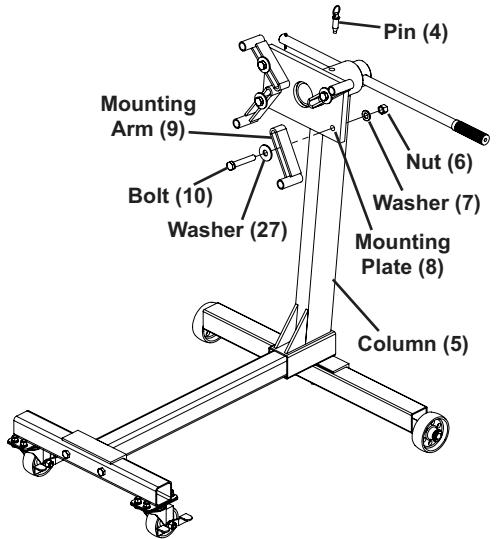

Figure E: Installing Arms and Locking Rotation

7. Attach the Mounting Arms (9) to the slots in the Mounting Plate (8) using the Bolts (10), Washers (7), and Nuts (6).
8. To lock Mounting Plate (8) rotation, align a hole on it with the hole on the top of the Column (5), and insert the Pin (4).

PITTSBURGH[®]

Operating Instructions



Read the ENTIRE IMPORTANT SAFETY INFORMATION section at the beginning of this document including all text under subheadings therein before set up or use of this product.

Mounting Engine

⚠️ WARNING **TO PREVENT SERIOUS INJURY:** Before attaching an engine to the stand, confirm that its weight does not exceed the Stand maximum capacity.

1. Position Stand on a flat, level, hard and smooth surface capable of supporting the weight of Stand and engine. Lock Locking Swivel Casters.
2. Remove the Pin (4) from the Column (5).
3. Determine the thread type and length of bolts (not included) needed to thread into the engine block. Use grade 8 bolts that are long enough to fit through the Arms and thread as deeply as possible into the engine block.
4. Align the Mounting Arms (9) with four mounting bolt locations on the engine.
5. Place the bolts (not included) through the Mounting Plate (8) side and securely tighten them into the engine. The bolt heads must press against the back of the Arms: if needed, use flat washers (not included) as spacers.
6. Tighten the Bolts (10) and Nuts (6) that hold the Mounting Arms (9) to the Mounting Plate (8) securely.
7. Slowly lower the hoist/engine crane (sold separately) until all the engine's weight is held by the stand.
8. Safely release the engine from the hoist/engine crane.
9. Slowly rotate the engine to the desired angle and insert the Pin (4) into the top of the Column (5).

WARNING! TO PREVENT SERIOUS INJURY: Use all four Arms when attaching an engine to the Stand.

Rotating Engine

⚠️ WARNING **TO PREVENT SERIOUS INJURY:** Be prepared for sudden engine movement before removing Pin. Stay clear of engine.

1. While holding onto the Handle (2) and the engine to prevent it from accidental rotation, remove Pin (4).
2. Use assistance to rotate the engine to the desired angle and insert the Pin (4) into the top of the Column (5).

Removing Engine

1. With assistance, rotate the engine to its initial position.
2. Secure the engine properly to the crane. Use the crane to support all of the engine's weight directly overhead, but do not start lifting the engine stand.
3. Once the engine is properly supported by the crane, remove the bolts securing the Mounting Arms (9) to the engine.

Maintenance and Servicing



Procedures not specifically explained in this manual must be performed only by a qualified technician.

⚠️WARNING

TO PREVENT SERIOUS INJURY FROM STAND FAILURE:

Do not use damaged equipment. Make sure the stand is stable. If any unsafe conditions are found, take it to a qualified technician for service or repair.

1. **BEFORE EACH USE**, inspect the general condition of the Stand. Check it for cracks, bends in the metal, signs of unusual wear or any other condition that may affect its safe operation. If any are found, do not use the Stand.
2. Keep Engine Stand clean and free of dirt or grease.
3. Before each use, check that hardware is securely fastened.
4. Check that the Casters are clean and turn properly.
5. **AFTER USE**, clean external surfaces of the stand with a clean, moist cloth.

PLEASE READ THE FOLLOWING CAREFULLY

THE MANUFACTURER AND/OR DISTRIBUTOR HAS PROVIDED THE PARTS LIST AND ASSEMBLY DIAGRAM IN THIS DOCUMENT AS A REFERENCE TOOL ONLY. NEITHER THE MANUFACTURER OR DISTRIBUTOR MAKES ANY REPRESENTATION OR WARRANTY OF ANY KIND TO THE BUYER THAT HE OR SHE IS QUALIFIED TO MAKE ANY REPAIRS TO THE PRODUCT, OR THAT HE OR SHE IS QUALIFIED TO REPLACE ANY PARTS OF THE PRODUCT. IN FACT, THE MANUFACTURER AND/OR DISTRIBUTOR EXPRESSLY STATES THAT ALL REPAIRS AND PARTS REPLACEMENTS SHOULD BE UNDERTAKEN BY CERTIFIED AND LICENSED TECHNICIANS, AND NOT BY THE BUYER. THE BUYER ASSUMES ALL RISK AND LIABILITY ARISING OUT OF HIS OR HER REPAIRS TO THE ORIGINAL PRODUCT OR REPLACEMENT PARTS THERETO, OR ARISING OUT OF HIS OR HER INSTALLATION OF REPLACEMENT PARTS THERETO.

Record Serial Number Here: _____

Note: If product has no serial number, record month and year of purchase instead.

Note: Some parts are listed and shown for illustration purposes only, and are not available individually as replacement parts. Specify UPC 193175459640 when ordering parts.

Parts List and Diagram

Part	Description	Qty
1	Handle Grip	1
2	Handle	1
3	Cotter Pin	1
4	Pin	1
5	Column	1
6	Nut M12	4
7	Washer 12	4
8	Mounting Plate	1
9	Mounting Arm	4

Part	Description	Qty
10	Bolt M12x70	4
11	Front Beam	1
12	Bolt M10x70	2
13	Washer 10	2
14	Nut M10	2
15	Bolt M8x20	8
16	Washer 8	8
17	Lock Washer 8	8
18	Nut M8	8

Part	Description	Qty
19	3" Caster	2
20	Middle Beam	1
21	Lock Washer 12	1
22	Bolt M12x80	1
23	Rear Beam	1
24	Wheel	2
25	Washer 14	2
26	Snap Ring 12	2
27	Washer 12	4

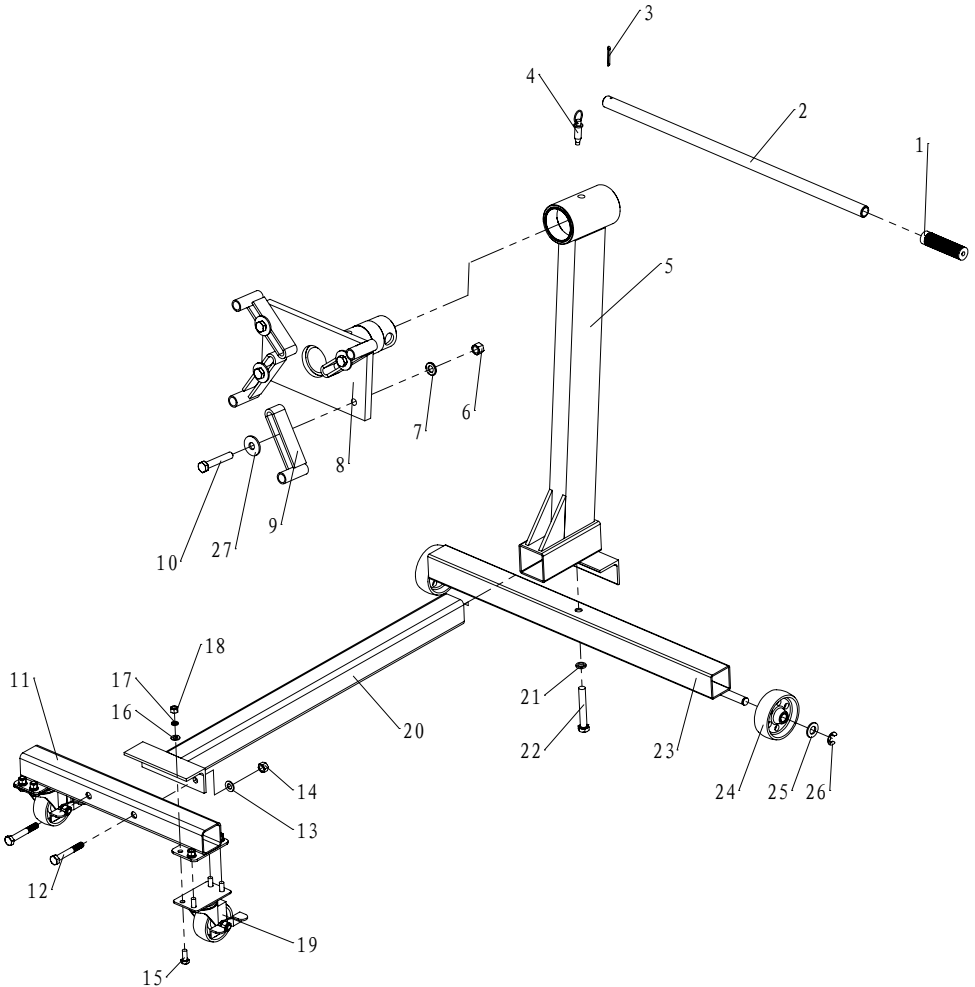

Limited 90 Day Warranty

Harbor Freight Tools Co. makes every effort to assure that its products meet high quality and durability standards, and warrants to the original purchaser that this product is free from defects in materials and workmanship for the period of 90 days from the date of purchase. This warranty does not apply to damage due directly or indirectly, to misuse, abuse, negligence or accidents, repairs or alterations outside our facilities, criminal activity, improper installation, normal wear and tear, or to lack of maintenance. We shall in no event be liable for death, injuries to persons or property, or for incidental, contingent, special or consequential damages arising from the use of our product. Some states do not allow the exclusion or limitation of incidental or consequential damages, so the above limitation of exclusion may not apply to you. THIS WARRANTY IS EXPRESSLY IN LIEU OF ALL OTHER WARRANTIES, EXPRESS OR IMPLIED, INCLUDING THE WARRANTIES OF MERCHANTABILITY AND FITNESS.

To take advantage of this warranty, the product or part must be returned to us with transportation charges prepaid. Proof of purchase date and an explanation of the complaint must accompany the merchandise. If our inspection verifies the defect, we will either repair or replace the product at our election or we may elect to refund the purchase price if we cannot readily and quickly provide you with a replacement. We will return repaired products at our expense, but if we determine there is no defect, or that the defect resulted from causes not within the scope of our warranty, then you must bear the cost of returning the product.

This warranty gives you specific legal rights and you may also have other rights which vary from state to state.

PITTSBURGH[®]