

Product Model

POW-SunSmart 8K; POW-SunSmart 10K

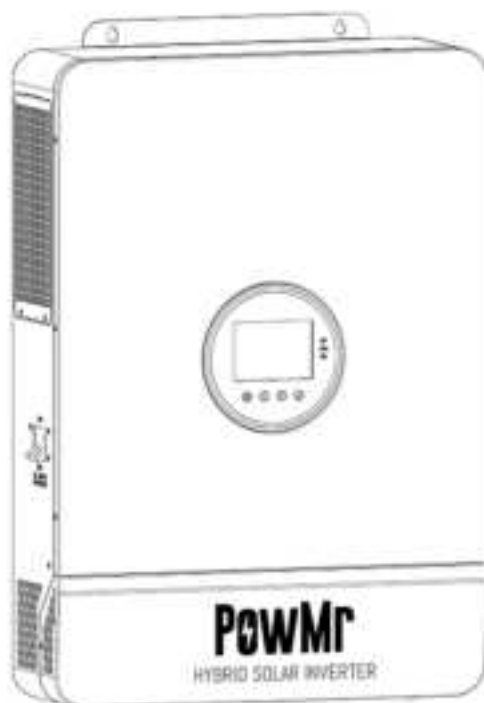

POWMr

All-in-one solar charge inverter

User Manual

Important Safety Instructions

Please save these instructions for future use!

-  Read all of the instructions and cautions in the manual before beginning the installation !
- Installation and wiring must comply with the Local and National Electric Codes (NEC) and must be done by a certified technician.
 - Do NOT disassemble or attempt to repair the inverter. There are no serviceable parts for this inverter.
 - DO NOT parallel this device with other AC input sources to avoid damage.
 - DO NOT attempt to touch the unit while it is operating as temperatures will be very hot. In addition, do not open the terminal cover while the unit is in operation.
 - Make sure all connections going into and from the inverter are tight. There may be sparks when making connections, therefore, make sure there are not flammable materials or gases near installation.
 - Installing breakers or fuses outside of the unit is recommended.
 - After installation, check that all line connections are tight and secured.
 - Do NOT let the positive (+) and negative (-) terminals of the battery touch each other. Use Lithium batteries or deep cycle Sealed Lead Acid, Flooded, Gel, AGM batteries.
 - Explosive battery gases may be present while charging. Be certain there is enough ventilation to release the gases.
 - Be careful when working with large lead acid batteries. Wear eye protection and have fresh water available in case there is contact with the battery acid.
 - Over-charging and excessive gas precipitation may damage the battery plates and activate material shedding on them. Too high of an equalizing charge or too long of one may cause damage. Please carefully review the specific requirements of the battery used in the system.

Table of Contents

Important Safety Instructions.....	1
1 About This Manual	2
1.1 How to Use This Manual	2
1.2 Symbols in This Manual.....	2
2 Production Instructions	3
2.1 Instructions.....	3
2.2 Features.....	3
2.3 System Connection Diagram	5
2.4 Production Overview	6
3 Installation.....	7
3.1 Select the Mount location	7
3.2 Mount the Inverter	8
3.3 Remove the Terminal Cover and Insect Screen.....	8
4 Connection.....	9
4.1 Connection Overview	9
4.2 Cable & Circuit Breaker Requirement.....	12
4.3 AC Input & Output Connection	14
4.4 Battery Connection.....	14
4.5 PV Connection	15
4.6 Dry Contact Connection	16
4.7 Grounding Connection.....	16
4.8 Inverter Start.....	16
5 Operation.....	17
5.1 Operation and Display Panel	17
5.2 Display panel.....	18
5.3 View real-time data.....	20
5.4 Setting	21
5.5 AC Output Mode	32
5.6 Battery Charging Mode.....	33

5.7 Time-slot Charging/Discharging Function.....	34
5.8 Battery Parameters.....	35
6 Communication.....	37
6.1 Overview.....	37
6.2 USB-B Port.....	37
6.3 RS485-1 Port.....	38
6.4 RS485-2 Port.....	38
6.5 Dry Contact Port.....	39
7 Fault Codes and Response Measures.....	42
7.1 Fault Codes.....	42
7.2 Trouble Shooting.....	45
8 Protection Function and Product Maintenance.....	47
8.1 Protection Function.....	47
8.2 Maintenance.....	49
9 Parameter Table.....	50

1 About This Manual

1.1 How to Use This Manual

This manual contains important information, guidelines, operation and maintenance for the following products: POW-SunSmart 8K; POW-SunSmart 10K.

The manual must be followed during installation and maintenance.

All content related to parallel operation in this manual is applicable only to models designed for parallel operation.

1.2 Symbols in This Manual

Symbol	Description
DANGER	DANGER indicates a hazardous situations which if not avoided will result in death or serious injury.
WARNING	WARNING indicates a hazardous situations which if not avoided could result in death or serious injury.
CAUTION	CAUTION indicates a hazardous situations which if not avoided could result in minor or moderate injury.
NOTICE	NOTICE provide some tips on operation of products.

2 Production Instructions

2.1 Instructions

POW-SunSmart series is a new type of solar energy storage inverter control inverter integrating solar energy storage & utility charging and energy storage, AC sine wave output. It adopts DSP control and features high response speed, reliability, and industrial standard through an advanced control algorithm. It applies to industrial scenarios.

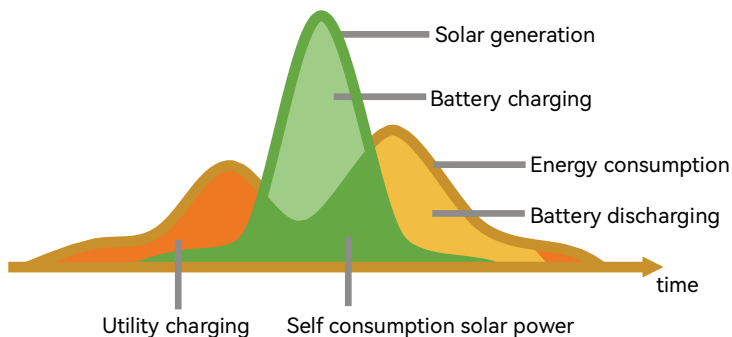

2.2 Features

- Supports lead acid battery and li-ion battery connections.
- With a dual activation function when the li-ion battery is dormant; either mains/photovoltaic power supply access can trigger the activation of the li-ion battery.
- Support split-phase and single-phase pure sine wave output.
- Supports four different voltage levels of 100Vac, 105Vac, 110Vac, 115Vac, 120Vac and 127Vac per phase.
- Supports two solar inputs and simultaneous tracking of two solar maximum power charging/carrying capacity functions.
- Dual MPPT with 99.9% efficiency and maximum 22A current in a single circuit, perfectly adapted to high power modules.
- charging modes are available: solar only, and mixed mains/PV charging.

- With the time-slot charging and discharging setting function, you can set the time period for cutting in/out of mains charging and switch the time period between battery discharging and mains bypass power supply mode.
- Energy saving mode function to reduce no-load energy losses.
- With two output modes of utility bypass and inverter output, with uninterrupted power supply function.
- LCD large screen dynamic flow diagram design, easy to understand the system data and operation status.
- 360° protection with complete short circuit protection, over current protection, over under voltage protection, overload protection, backfill protection, etc.
- Support CAN, USB, and RS485 communication.

2.3 System Connection Diagram

The diagram below shows the system application scenario of this product. A complete system consists of the following components:

1. **PV modules:** converts light energy into DC energy, which can be used to charge the battery via an inverter or directly inverted into AC power to supply the load.
2. **Utility grid or generator:** connected to the AC input, it can supply the load and charge the battery at the same time. The system can also operate generally without the mains or generator when the battery and the PV module power the load.
3. **Battery:** The role of the battery is to ensure the regular power supply of the system load when the solar energy is insufficient and there is no mains power.
4. **Home load:** Various household and office loads can be connected, including refrigerators, lamps, televisions, fans, air conditioners, and other AC loads.
5. **Inverter:** The energy conversion device of the whole system.

The actual application scenario determines the specific system wiring method.

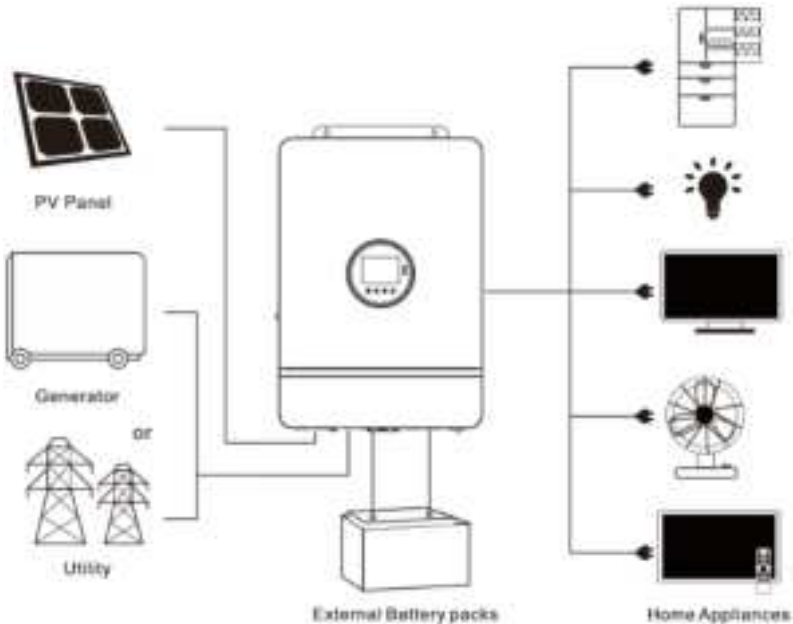

2.4 Production Overview

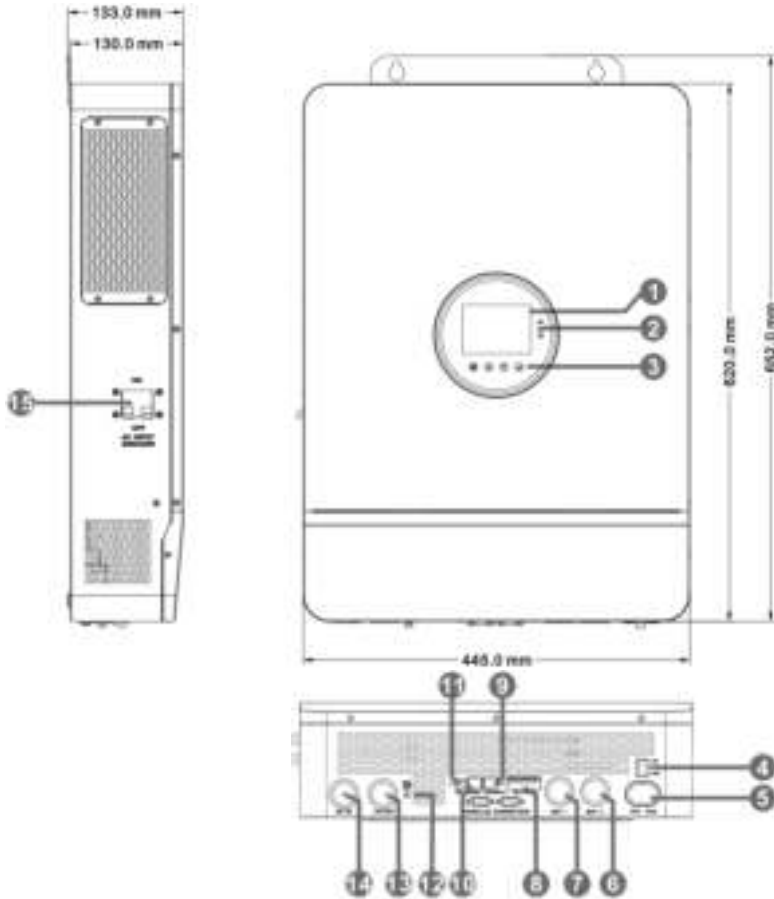

1	LCD Screen	2	LED Indicators	3	Touchable key
4	ON/OFF Rocker Switch	5	PV INPUT (1/1)	6	BAT INPUT (+)
7	BAT INPUT (-)	8	Dry contact	9	CAN/RS485 port
10	WIFI Port	11	USB-B port	12	Grounding Screw
13	AC OUT (L1+L2+N)	14	AC IN (L1+L2+N)	15	AC INPUT breaker

3 Installation

3.1 Select the Mount location

POW-SunSmart series are designed for **INDOOR USE ONLY** (IP20) . Please consider the followings before selecting the location.

- Choose the solid wall to install the inverter.
- Mount the inverter at eye level.
- Adequate heat dissipation space must be provided for the inverter.
- The ambient temperature should be between $-10\sim 55^{\circ}\text{C}$ ($14\sim 131^{\circ}\text{F}$) to ensure optimal operation.

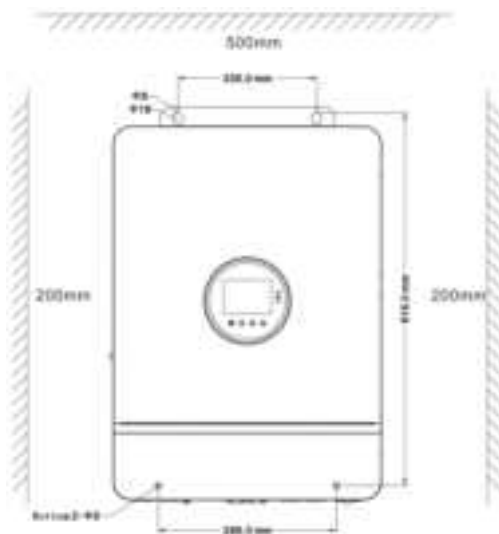

DANGER

- Do not install the inverter where highly flammable materials are nearby.
- Do not install the inverter in potential explosive areas.
- Do not install the inverter with lead-acid batteries in a confined space.

CAUTION

- Do not install the inverter in direct sunlight.
- Do not install or use the inverter in a humid environment.

3.2 Mount the Inverter

Make 4 mounting holes in the wall with an electric drill according to the specified dimensions, insert 2 expansion screws above and fix the inverter with 2 M5 screws below.

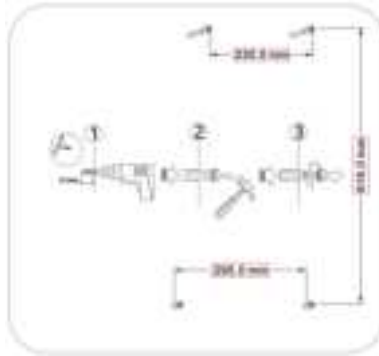

3.3 Remove the Terminal Cover and Insect Screen

Using a screwdriver, remove the terminal protection cover and insect screen.

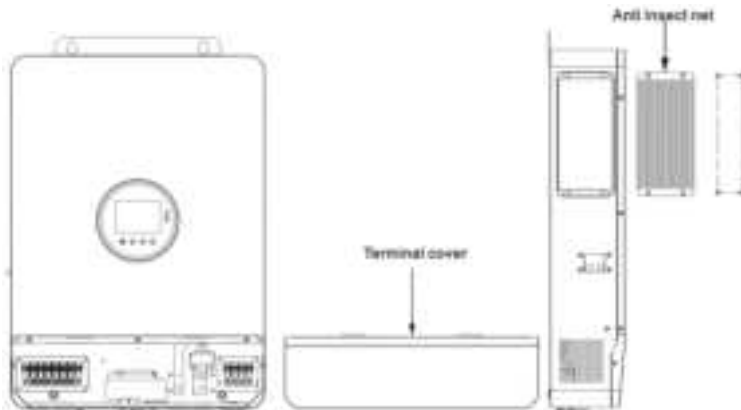

NOTICE

- When using the device in areas with poor air quality, the dust screen is easily blocked by airborne particles. Please dismantle and clean the dust screen regularly to avoid affecting the internal air flow rate of the inverter, which may trigger an over-temperature protection fault (19/20 fault) affecting the use of the power supply and the service life of the inverter.

4 Connection

4.1 Connection Overview

- Split-phase mode(default)

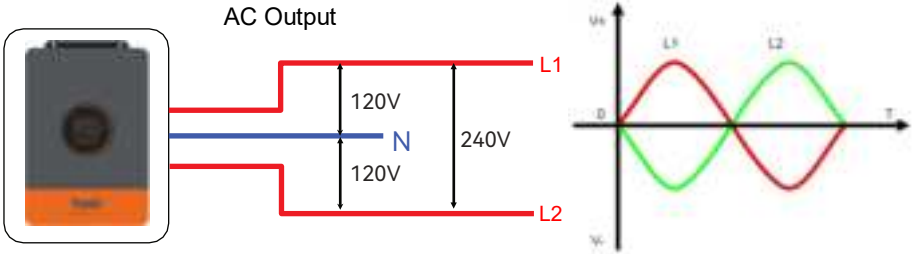

Items	Description
Applicable Model	POW-SunSmart 8K; POW-SunSmart 10K
Output Voltage Range (L-N)	100 ~ 120Vac, 120Vac default
Output Voltage Range (L-L)	200 ~ 240Vac, 240Vac default

- Single-phase mode

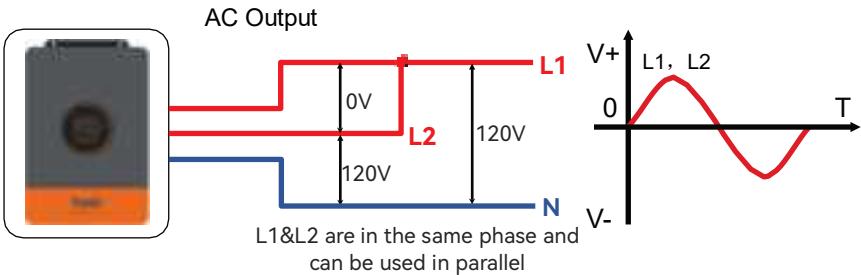

Items	Description
Applicable Model	POW-SunSmart 8K; POW-SunSmart 10K
Output Voltage Range (L-N)	100 ~ 120Vac, 120Vac default

Split-phase Mode

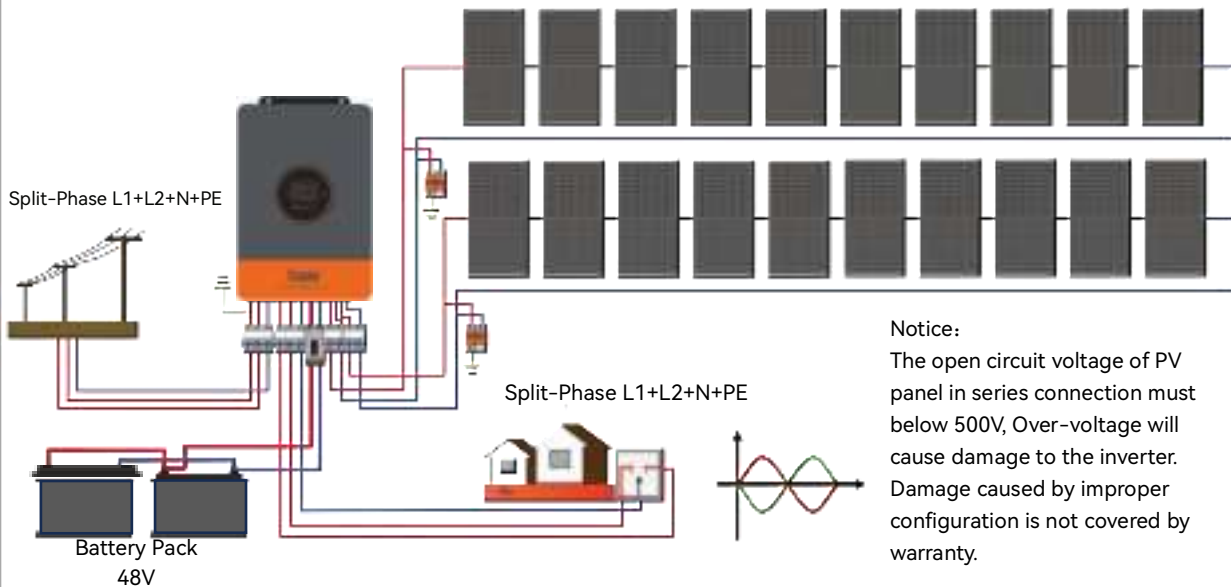

Single-phase Mode

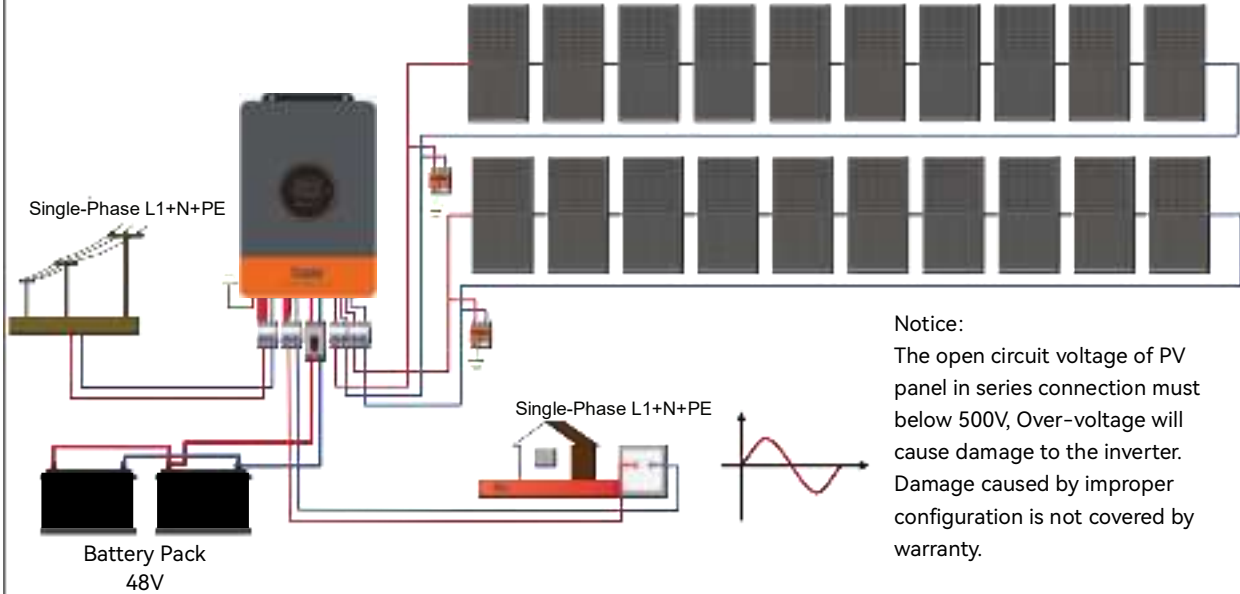

Notice:
The open circuit voltage of PV panel in series connection must be below 500V, Over-voltage will cause damage to the inverter. Damage caused by improper configuration is not covered by warranty.

4.2 Cable & Circuit Breaker Requirement

● PV INPUT

Model	Cable Diameter	Max.PV Input Current	Circuit Breaker Spec
8KW Model	5mm ² / 10 AWG	22A	2P-25A
10KW Model	5mm ² / 10 AWG	22A	2P-25A

● AC INPUT

Model	Output Mode	Diagram	Max. Input Current	Cable Diameter	Circuit Breaker Spec
8KW Model	Split-phase		63A(L1/L2/N)	13mm ² /6AWG (L1/L2/N)	3P-63A
	Single-phase		63A(L1/L2) 126A(N)	13mm ² /6AWG(L1/L2) 26mm ² /3AWG(N)	2P-125A
10KW Model	Split-phase		63A(L1/L2/N)	13mm ² /6AWG (L1/L2/N)	3P-63A
	Single-phase		63A(L1/L2) 126A(N)	13mm ² /6AWG(L1/L2) 26mm ² /3AWG(N)	2P-125A

● BATTERY

Model	Cable Diameter	Max.Battery Current	Circuit Breaker Spec
8KW Model	34mm ² / 2 AWG	180A	2P-200A
10KW Model	42mm ² / 1 AWG	220A	2P-250A

● AC OUTPUT

Model	Output Mode	Diagram	Max.Output Current	Cable diameter	Circuit Breaker Spec
8KW Model	Split-phase		42A (L1/L2/N)	13mm ² /6AWG (L1/L2/N)	3P-63A
	Single-phase		42A (L1/L2) 84A(N)	13mm ² /6AWG(L1/L2) 26mm ² /3AWG(N)	2P-125A
10KW Model	Split-phase		63A (L1/L2/N)	13mm ² /6AWG (L1/L2/N)	3P-63A
	Single-phase		63A (L1/L2) 126A(N)	13mm ² /6AWG(L1/L2) 26mm ² /3AWG(N)	2P-125A

NOTICE

● PV INPUT, AC INPUT, AC OUTPUT

1. Use a stripper to remove the 6~8mm insulation of the cable.
2. Fixing a ferrule at the end of the cable. (ferrule needs to be prepared by the user)

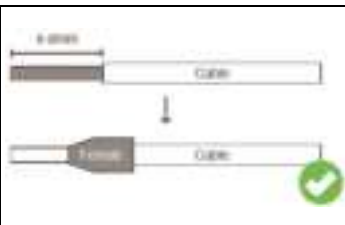

● BATTERY

1. Use a stripper to remove the 6~8mm insulation of the cable
2. Fixing cable lugs that supply with the box at the end of the cable.

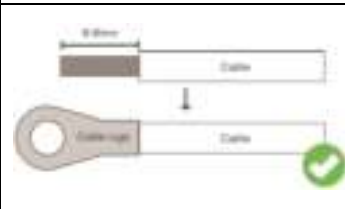

The wire diameter is for reference only. If the distance between the PV array and the inverter or between the inverter and the battery is long, using a thicker wire will reduce the voltage drop and improve the performance of the system.

4.3 AC Input & Output Connection

Connect the live, neutral and ground wires according to the cables' position and order shown in the diagram below. (1.5NM)

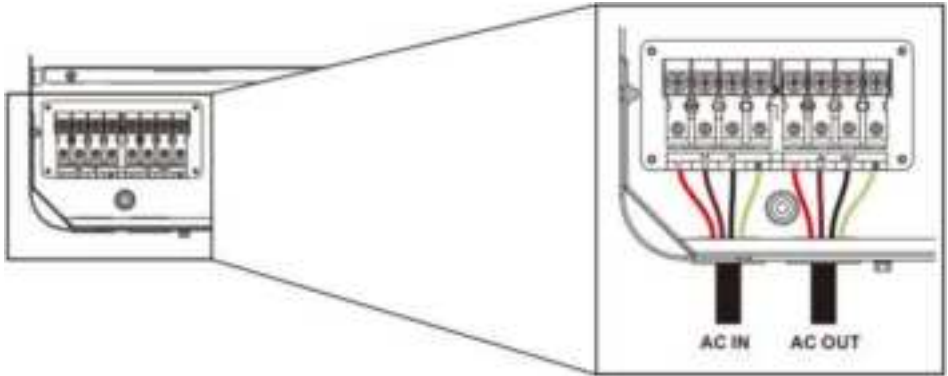

DANGER

- Before connecting AC inputs and outputs, the circuit breaker must be opened to avoid the risk of electric shock and must not be operated with electricity.
- Please check that the cable used is sufficient for the requirements, too thin, poor quality cables are a serious safety hazard.

4.4 Battery Connection

Connect the positive and negative cable of the battery according to the diagram below. (3NM)

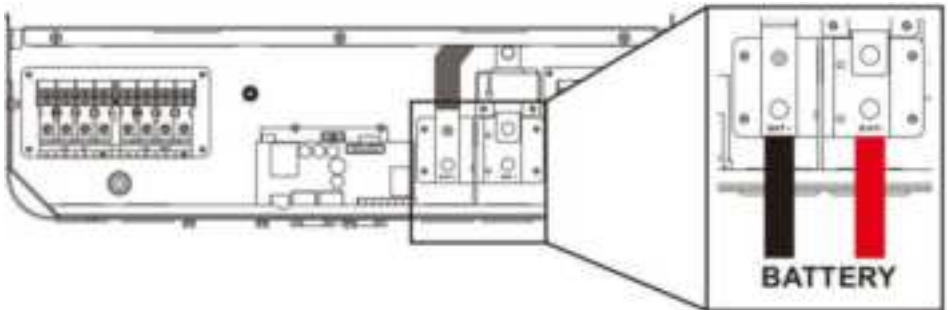

DANGER

- Before connecting battery, the circuit breaker must be opened to avoid the risk of electric shock and must not be operated with electricity.
- Make sure that the positive and negative terminals of the battery are connected correctly and not reversed, otherwise the inverter may be damaged.
- Please check that the cable used is sufficient for the requirements, too thin, poor quality cables are a serious safety hazard.

4.5 PV Connection

Connect the positive and negative wires of the two strings of PV according to the diagram below.
(1.2NM)

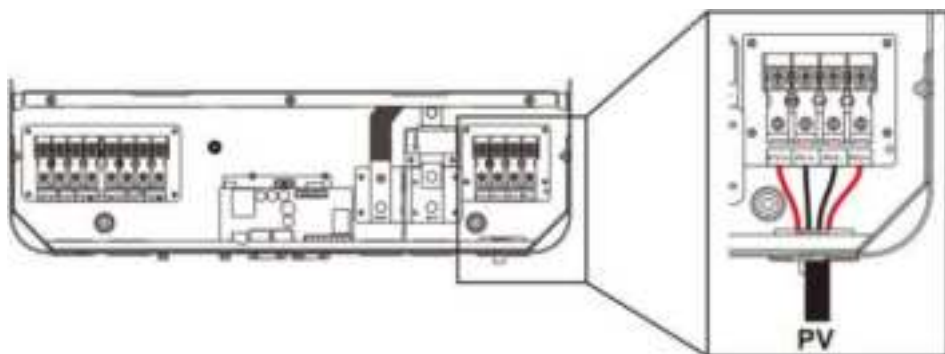
**DANGER**

- Before connecting PV, the circuit breaker must be opened to avoid the risk of electric shock and must not be operated with electricity.
- Please make sure that the open circuit voltage of the PV modules in series does not exceed the Max. Open Circuit Voltage of the inverter (In the POW-SunSmart series, this value is 500V), otherwise the inverter may be damaged.

4.6 Dry Contact Connection

Use a small screwdriver to push back the direction indicated by the arrow, then insert the communication cable into the dry junction port. (Communication cable diameter 0.2~1.5mm²)

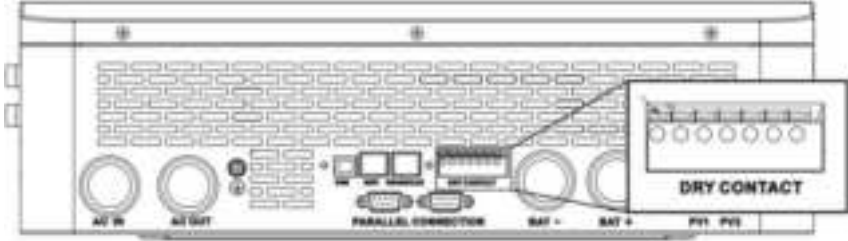

4.7 Grounding Connection

Please make sure the grounding terminal connect to the Grounding Busbar. (2NM)

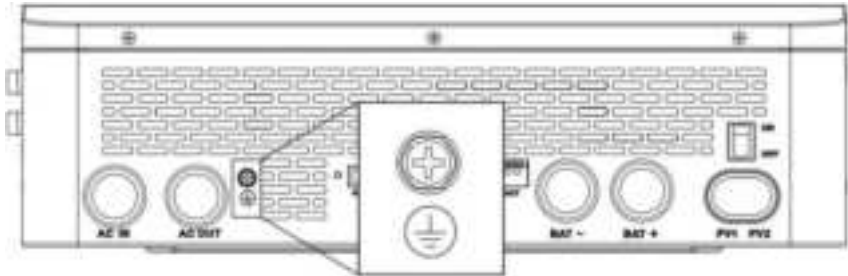

NOTICE

- The grounding cable should have a diameter of not less than 4 mm² and be as close as possible to the grounding point.

4.8 Inverter Start

After confirming reliable wiring and correct wiring sequence, restore the terminal cover to its original position

- Step 1. Close the circuit breaker of the battery
- Step 2. Press the rocker switch at the bottom of the inverter, and the screen and indicator will light up, indicating that the inverter is enabled
- Step 3. Close the circuit breakers for PV input, AC input, and AC output in sequence
- Step 4. Start loads one by one in order of power from small

5 Operation

5.1 Operation and Display Panel

The operation and display panel below includes 1 LCD screen, 3 indicators, 4 touchable keys.

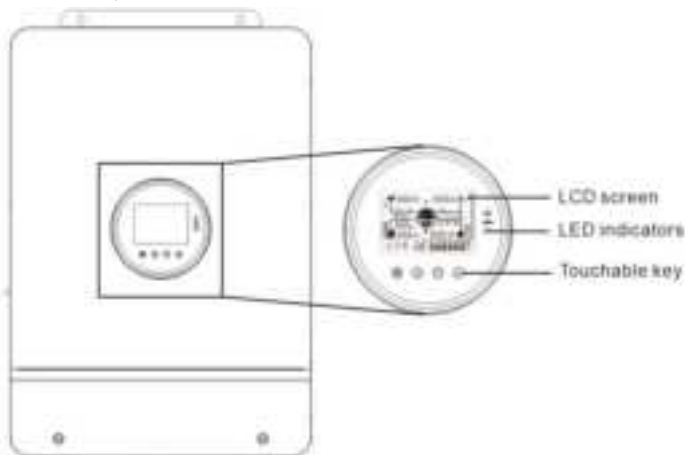

● Touchable Keys

Touchable Keys	Description
	Enter/exit the setting menu
	Go to the next selection
	Go to the previous selection
	Confirm/Enter the selection in setting menu

● LED Indicators

Indicators	Color	Description
AC/INV	Yellow	Steady on: utility grid bypass output
		Flash: inverter output
CHARGE	Green	Steady on: charging complete
		Flash: charging
FAULT	Red	Steady on: level-1 fault
		Flash: level-2 fault
		Off: level-3 fault or level-4 fault

5.2 Display panel

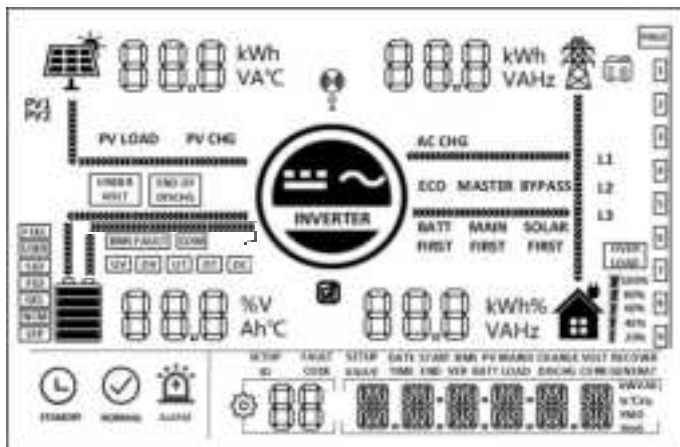

Icon	Description	Icon	Description
	Indicates the PV panel		Indicates the utility grid
	Indicates the battery		Indicates the generator
	Indicates the inverter is working		Indicates the home load
	Indicates the inverter is communicating with data collector		Indicates the buzzer muted
	Indicates the direction of energy flow		
	Indicates the inverter is standby		Indicates the inverter is working normally
	Indicates error occur		Indicates setting
	Indicates load power 80%~100%		Indicates battery SOC 80%~100%
	Indicates load power 60%~79%		Indicates battery SOC 60%~79%

	Indicates load power 40%~59%		Indicates battery SOC 40%~59%
	Indicates load power 20%~39%		Indicates battery SOC 20%~39%
	Indicates load power 5%~19%		Indicates battery SOC 5%~19%
UNDER VOLT	Indicates battery under-voltage	END OF DISCHG	Indicates battery discharge
OVER LOAD	Indicates over-load	BMS FAULT	Indicates BMS fault
COM	Indicates system communication error	UV	Indicates system under-voltage
OV	Indicates system over-voltage	UT	Indicates system under-temperature
OT	Indicates system over-temperature	OC	Indicates system over-current
FULL	Indicates battery is full	USER	Indicates user defined battery
SLD	Indicates sealed lead-acid battery	FLD	Indicates flooded lead-acid battery
GEL	Indicates gel lead-acid battery	NCM	Indicates ternary li-ion battery
LFP	Indicates LFP li-ion battery	ECO	Indicates energy-saving mode
PV LOAD	Indicates PV energy is carrying the load	PV CHG	Indicates PV energy is charging the battery
AC CHG	Indicates AC IN energy is charging the battery	MAIN FIRST	Indicates the inverter output mode is mains power first
BYPASS	Indicates the inverter output mode is bypass	SOLAR FIRST	Indicates the inverter output mode is solar first
BATT FIRST	Indicates the inverter output mode is battery first		

5.3 View real-time data

In the main screen, press the UP / DOWN keys to view the real-time data of the inverter during operation.

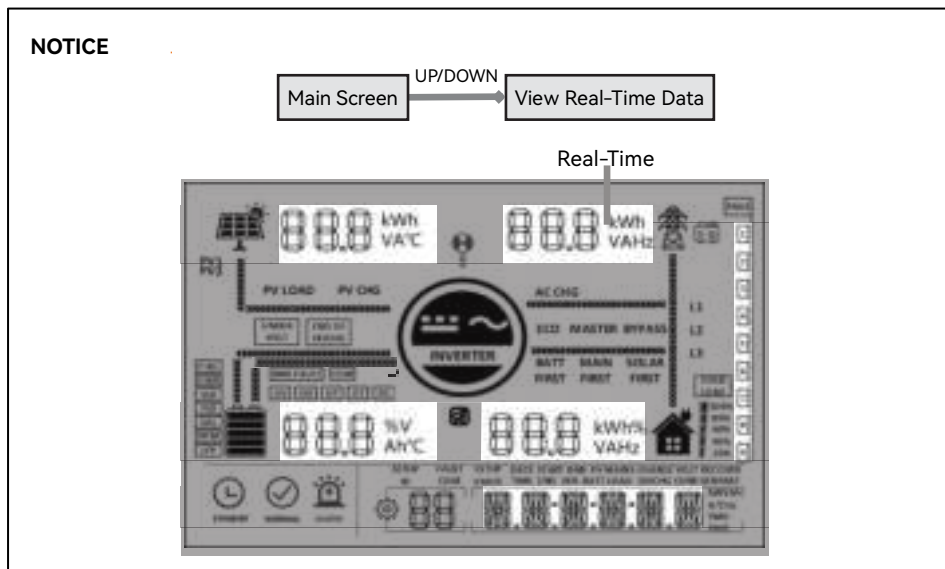

Page	PV side	BAT side	AC IN side	LOAD side	General
1	PV input voltage	Batt Voltage	AC input voltage	Single phase voltage	Current Time
2	PV input current	Batt Current	AC input current	Single phase Current	Current Date
3	PV input power	Batt Voltage	Total AC input power	Single phase active power	PV Total kWh
4	PV today kWh	Batt Current	Today AC charging kWh	Single phase apparent power	Load Total kWh
5	PV side heat sink temperature	INV Heat Sink Temperature	AC frequency	AC output frequency	RS485 Address
6	PV open circuit voltage	Batt Rated Voltage	Busbar voltage	Rated output frequency	Software Version
7	Max. PV charging current	Max. Batt charging current	Max. AC charging Current	Total AC output active power	/
8			/	Total AC output apparent power	/

5.4 Setting

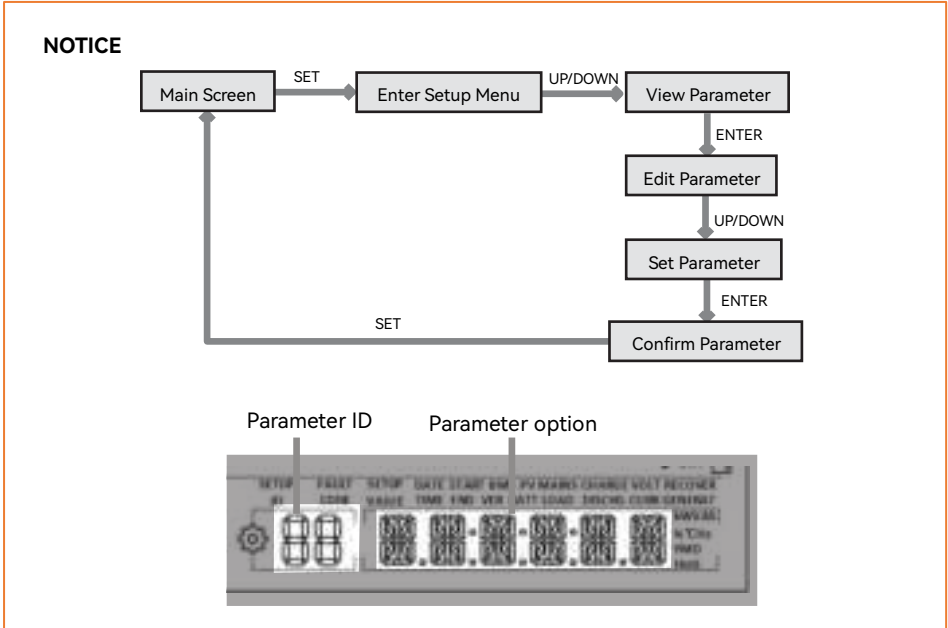

ID	Parameter Meaning	Options	Description
00	Exit	ESC	Exit the setup menu.
01	AC output source priority	UTI	Photovoltaic energy priority with the load, photovoltaic is not enough, the grid power and photovoltaic mixed load, photovoltaic energy is enough with the load, the excess energy to charge the battery, the grid power only starts charging when the battery is too discharged (06 Settings as "OSO (only PV)", the grid power will not charge), the battery is only discharged when off the grid
		SBU	Inverter first. The PV mode is to be applied first for loading, and only when the battery voltage is lower than the set value in the item 4, it will

			switch to the mains mode for loading. When the battery voltage is higher than the set value in the item 5, it will switch back to the PV mode from the mains mode.
		SOL	The PV mode is to be applied first and when the PV power is unavailable or the battery voltage is lower than the set value in the item 4, it will switch to the mains mode.
		SUB default	Solar energy priority charging, insufficient solar energy, grid energy and solar energy hybrid charging (if 06 Settings as “OSO (only PV)”, the grid energy will not charge) and grid with load, when solar energy is enough to charge, excess energy not enough to load, excess solar energy and grid will hybrid load, the battery is discharged only when off the grid.
02	AC output frequency	50.0	In bypass mode, the AC output frequency will adapt to the mains frequency, and in other cases, the output will follow the preset value.
		60.0 default	
03	AC input voltage range	UPS default	When output range is 110/120V, input voltage range 90~140V.
		APL	When output range is 100/105V, input voltage range 85~140V.
04	Battery to mains voltage threshold	43.6 default	When the parameter item 01 is SBU or SOL and the battery voltage is lower than the threshold, the output

			switches from inverter to mains. Setting range: 40 V~52 V.
05	Mains to battery voltage threshold	57.6 default	When the parameter item 01 is SBU or SOL and the battery voltage is higher than the threshold, the output switches from mains to inverter. Setting range: 48~60V.
06	Battery charging mode	SNU default	When both PV power and mains are used to charge the battery at one time, the PV charge first and when the PV power is insufficient, the mains tags in. Only in bypass mode can both PV power and mains be used to charge the battery at one time, and only the PV charge mode can be enabled during inverter operation.
		OSO	Do not enable the mains charge mode when in only PV charge mode.
07	Max. charging current (Grid+PV)	60	8KW model current setting range: 0~180A
			10KW model current setting range: 0~200A.
08	Battery type	USER	User-defined, user can set all battery parameter.
		SLD	Sealed lead-acid battery.
		FLD	Flooded lead-acid battery.
		GEL default	Gel lead-acid battery.
		L14\L15\L16	LFP battery L14/L15/L16, corresponding to 14, 15, and 16 series of LFP batteries.

		N13/N14	Ternary Li-ion battery N13/N14, corresponding to 13 and 14 series of ternary Li-ion batterie.
		NOb	No battery mode. Note: The no-battery mode requires connection to the grid for operation.
09	Battery boost charging voltage	57.6	Setting range:48V~58.4V, increment of each click is 0.4V, parameter can be set only when battery type is USER and L14/15/16, N13/14.
10	Boost charging duration	120	The continuous charging time when the voltage reaches the set voltage during constant voltage charging, with a setting range of 5 min~900 min and a step of 5 min.
11	Battery float charging voltage	55.2	Setting range: 48V~58.4V, with a step of 0.4 V. The parameters cannot be set only after successful BMS communication.
12	Battery over-discharge voltage (delayed shutdown)	42	When the battery voltage is lower than the voltage and triggers the set value in the item 13, it will turn off the inverter output. Setting range: 40 V~48 V, with a step of 0.4 V
13	Battery over-discharge voltage delay time	5	When the battery voltage is lower than the set value in the item 12 and triggers the delay time set in this parameter item, it will turn off the inverter output. Setting range: 5s~50s, with a step of 5s.
14	Battery under-	44	When the battery voltage is lower than

	voltage alarm voltage		the threshold, it will give an under-voltage alarm and the output will not shut down. Setting range: 40 V~52 V, with a step of 0.4 V.
15	Battery discharge limit voltage	40	When the battery voltage is lower than the value, the output immediately shuts down. Setting range: 40 V~52 V, with a step of 0.4 V, available for user-defined and Li-ion batteries.
16	Battery equalization charging	DIS	Disable equalization charging.
		ENA default	Enable equalization charging, parameter can be set only when battery type is FLd\SLd\USER
17	Battery equalization charging voltage	58	Setting range: 48V~58V, increment of each click is 0.4V, parameter can be set only when battery type is FLd\SLd\USER
18	Battery equalization charging duration	120	Setting range: 5min~900min, increment of each click is 5min, parameter can be set only when battery type is FLd\SLd\USER
19	Battery equalization charging delay time	120	Setting range: 5min~900min, increment of each click is 5min, parameter can be set only when battery type is FLd\SLd\USER
20	Battery equalization charging interval	30	Setting range: 0~30 days, increment of each click is 1 day, parameter can be set only when battery type is FLd\SLd\USER
21	Battery	DIS default	Stop equalization charging

	equalization charging stop-start		immediately.
		ENA	Start equalization charging immediately.
22	Power saving mode	DIS default	Disable power saving mode.
		ENA	Enable power saving mode, When the load power below 50W, the inverter output will switch off after a 5min delay . When the load is more than 50W, the inverter automatic restart.
23	Over-load restart	DIS	Disable overload auto restart and when overload occurs, it will turn off the output and the inverter will no longer resume startup.
		ENA default	Enable overload auto restart, and If overload occurs, the output will be turned off, and after a delay of 3 min, the output will restart. After 5 cumulative attempts, the inverter will no longer resume startup.
24	Over-temperature auto restart	DIS	Disable over-temperature auto restart and when over-temperature occurs, it will turn off the output and the inverter will no longer turn on the output.
		ENA default	Enable over-temperature auto restart and when over-temperature occurs, it will turn off the output and the output will restart when the temperature drops.
25	Buzzer alarm	DIS	Disable buzzer alarm.

		ENA default	Enable buzzer alarm.
26	Mode switch prompt	DIS	Disable prompt when the status of the main input source changes.
		ENA default	Enable prompt when the status of the main input source changes.
27	Inverter to bypass switch	DIS	Disable auto switch to mains for loading in case of inverter overload.
		ENA default	Enable auto switch to mains for loading in case of inverter overload.
28	Max. grid charging current	60 default	For 8KW model, setting range: 0~100A.
			For 10KW model, setting range: 0~120A.
30	RS485 communication address	ID: 1	RS485 communication address setting range: 1~254.
32	RS485 communication function	SLA default	Enable PC and Remote Monitoring Protocol.
		485	Enable the BMS communication function based on RS485 communication.
		CAN	Enable the BMS communication function based on CAN communication.
33	BMS communication	Select the corresponding communication protocol in item 33 when you set it to 485 or CAN in item 32.	
		WOW default	485 protocol: PAC=PACE, RDA=RITAR, AOG=ALLGRAND, OLT=OLITER, CEF=CFE, XYD=SUNWODA, DAQ=DYNESS, WOW=SRNE,

			PYL=PYLONTECH, POW=POWMR, UOL=VILION, HWD=Sunwoda.
35	Battery under-voltage recovery threshold	52	When the battery is under voltage, the battery voltage needs to be greater than the threshold to restore the AC output of the battery inverter. Setting range: 44 V-54.4 V.
37	Recharge voltage threshold for fully charged battery	52	After the battery is fully charged, the inverter stops charging, and recovers charging when the battery voltage is lower than the threshold. Setting range: 44 V-54 V.
38	AC output voltage	120	Setting range: 100/105/110/115/120/127Vac
39	Charge current limit (when BMS works)	LCSET	The maximum battery charge current is not greater than the set value of [item 07].
		LCBMS default	The maximum battery charge current is not greater than the maximum value of BMS.
		LCINV	The maximum battery charge current is not greater than the logical judgment value of inverter.
40	Period-1 battery charge start time	00:00:00	Setting range: 00:00:00-23:59:00
41	Period-1 battery charge end time	00:00:00	Setting range: 00:00:00-23:59:00
42	Period-2 battery charge start time	00:00:00	Setting range: 00:00:00-23:59:00
43	Period-2 battery charge end time	00:00:00	Setting range: 00:00:00-23:59:00

44	Period-3 battery charge start time	00:00:00	Setting range: 00:00:00-23:59:00
45	Period-3 battery charge end time	00:00:00	Setting range: 00:00:00-23:59:00
46	Time slot charging function	DIS default	Disable this function.
		ENA	After the timed mains charge/loading function is enabled, the power supply mode will turn into SBU, where mains is available for power supply in the set period or after battery over-discharge. If the timed discharge function is enabled at the same time, the power supply mode of the system will be changed into UTI, where mains is only available for power supply in the set charge period, and the system only switches to the power supply of battery inverter during the set discharge period or mains failure.
47	Period-1 battery discharge start time	00:00:00	Setting range: 00:00:00-23:59:00.
48	Period-1 battery discharge end time	00:00:00	Setting range: 00:00:00-23:59:00.
49	Period-2 battery discharge start time	00:00:00	Setting range: 00:00:00-23:59:00.
50	Period-2 battery discharge end time	00:00:00	Setting range: 00:00:00-23:59:00.
51	Period-3 battery discharge start time	00:00:00	Setting range: 00:00:00-23:59:00.
52	Period-3 battery	00:00:00	Setting range: 00:00:00-23:59:00.

	discharge end time		
53	Time slot discharging function	DIS default	Disable this function.
		ENA	After the timed battery discharge function is enabled, the power supply mode will be changed into UTI, where the system only switches to the power supply of battery inverter during the set discharge period or mains failure.
54	Current date	00:00:00	YY/MM/DD. Setting range: 00:01:01-99:12:31.
55	Current time	00:00:00	Setting range: 00:00:00-23:59:59.
57	Charge stop current	3	The charge stops when the charge current is less than the set value. (unit: A)
58	SOC setting for discharge alarming	15	When the capacity is less than the set value, the SOC alarms. (unit: %, only available during normal BMS communication.)
59	SOC setting for discharge cutoff	5	When the capacity is less than the set value, the discharge stops. (unit: %, only available during normal BMS communication.)
60	SOC setting for charge cutoff	100	When the capacity is greater than the set value, the charge stops. (unit: %, only valid during normal BMS communication.)
61	SOC setting for switching to mains	10	When the capacity is less than the set value, it switches to mains. (unit: %, only available during normal BMS communication.)

62	SOC setting for switching to inverter output	100	When the capacity is greater than the set value, it switches to the inverter output mode. (unit: %, only available during normal BMS communication.)
63	Auto N-PE connection switch function	DIS default	Disable auto N-PE connection switch.
		ENA	Enable auto N-PE connection switch.
67	Power sales setting	0 default	Setting range: 0–rated power.
68	AC output phase mode	0	0 represents the single-phase mode Assuming that the AC output voltage of item 38 is 120 V, the phase difference of L1-L2 is 0°, and L1/L2 can be connected in parallel, the phase voltage of L1-N/L2-N is 120 V.
		180 default	180 represents the split-phase mode Assuming that the AC output voltage of item 38 is 120 V, the phase difference of L1-L2 is 180°, the phase voltage of L1-N/L2-N is 120 V, and the voltage of L1-L2 is 240 V.
		NO N	Without N-wire (When you set "No N", the phase difference is 180° default)

5.5 AC Output Mode

The AC output mode corresponds to parameter setting item 01, which allows the user to set the AC output power source manually.

● Utility Priority Output 01 UTI

Utility at first priority, utility and solar provide power to load at the same time when solar is available, battery will provide power to load only when utility power is not available. (Priority: utility>solar>battery)

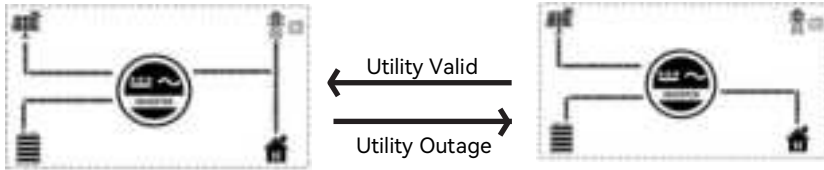

● Solar and Utility Hybrid Output 01 SUB (default)

Solar energy priority charging, insufficient solar energy, grid energy and solar energy hybrid charging (if 06 Settings as "OSO(only PV)", the grid energy will not charge) and grid with load, when solar energy is enough to charge, excess energy not enough to load, excess solar energy and grid will hybrid load, the battery is discharged only when off the grid

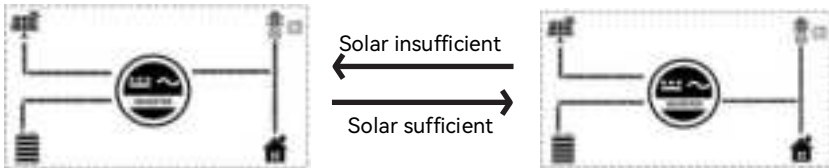

● Solar Priority Output 01 SOL

Solar provides power to the loads as first priority. If solar is not sufficient or not available, the utility will be used as a supplement to provide power to the loads. This mode maximizes solar energy while maintaining battery power and is suitable for areas with relatively stable power grids. (Priority: solar>utility>battery)

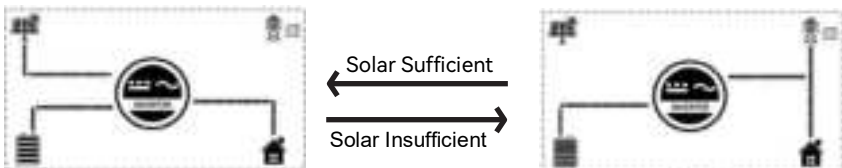

● **Inverter Priority Output 01 SBU**

Solar provides power to the loads as first priority. If solar is not sufficient or not available, the battery will be used as a supplement to provide power to the loads. When the battery voltage reaches the value of parameter 04(Voltage point of battery switch to utility) will switch to utility to provide power to the load, This model makes maximum use of DC energy and is used in areas where the grid is stable. (Priority: solar>battery>utility)

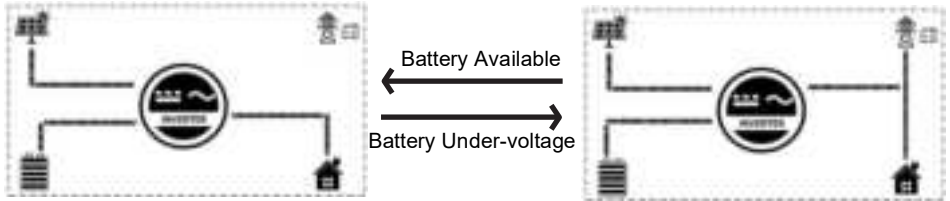

5.6 Battery Charging Mode

The charging mode corresponds to parameter setting item 06, which allows the user to set the charging mode manually.

● **Hybrid Charging SNU (default)**

Solar and utility charging the battery at the same time, solar at the first priority, utility power as a supplement when solar power is not sufficient. This is the fastest way to charge and is suitable for areas with low power supply, providing customers with sufficient back-up power. (Source priority: solar>utility)

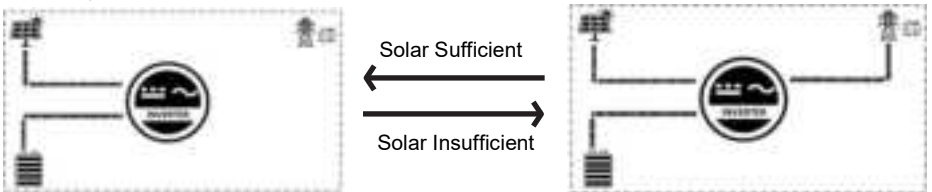

● **Only Solar Charging OSO**

Solar charging only, no mains charging is activated. This is the most energy-efficient method, with all the battery power coming from solar energy, and is usually used in areas with good radiation conditions.

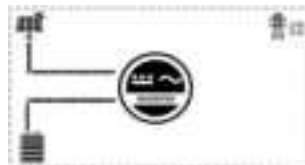

5.7 Time-slot Charging/Discharging Function

The POW-SunSmart series is equipped with a time-slot charging and discharging function, which allows users to set different charging and discharging periods according to the local peak and valley tariffs, so that the utility power and PV energy can be used rationally.

When mains electricity is expensive, the battery inverter is used to carry the load; when the mains electricity is cheap, the mains electricity is used to carry the load and charge, which can help customers to save electricity costs to the greatest extent.

The user can turn on/off the time-slot charging/discharging function in setup menu parameter 46 and 53. and set charging and discharging slot in parameter 40-45 and 47-52. You can set corresponding periods based on the local time-of-use price. Below are examples for users to understand the function.

NOTICE

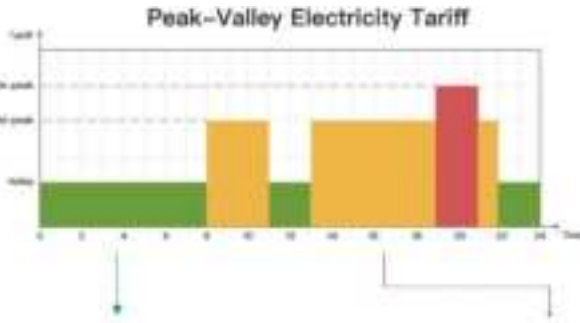

Timed charge and loading function



With 3 definable periods, users can freely set the mains charge/loading period in the range of 00:00-23:59. During the period set by the user, in case of PV energy output, it will be used first; in case of no PV energy output or lack of PV energy, mains will be used as a supplement.

Timed battery discharge function



With 3 definable periods, users can freely set the battery discharge period in the range of 00:00-23:59. During the period set by the user, the inverter will first use the battery inverter to load; if the battery power is insufficient, the inverter will automatically switch to mains to ensure stable operation of the load.

5.8 Battery Parameters

- Lead-acid battery

Parameter	Battery type	Sealed	Gel	Flooded	User-defined
		SLd	GEL	FLd	USER
Over-voltage cut-off voltage		60V	60V	60V	60V
Equalization charging voltage		58V	56.8V	58V	40~60V settable
Bulk charging voltage		57.6V	56.8V	57.6V	40~60V settable
Float charging voltage		55.2V	55.2V	55.2V	40~60V settable
Under-voltage alarm voltage		44V	44V	44V	40~60V settable
Under-voltage cut-off voltage		42V	42V	42V	40~60V settable
Discharging limit voltage		40V	40V	40V	40~60V settable
Over-discharge delay time		5s	5s	5s	1~30s settable
Equalization charging duration		120min	-	120min	0~600 min settable
Equalization charging interval		30days	-	30days	0~250 days settable
Bulk charging duration		120min	120min	120min	10~600min settable

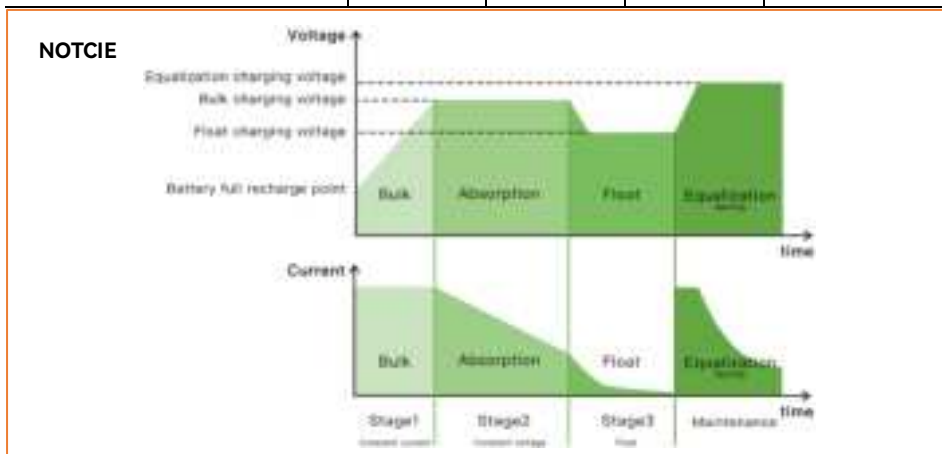

● Li-ion battery

Battery type Parameter	Ternary Li-ion		LFP			User-defined
	N13	N14	L16	L15	L14	USER
Over-voltage cut-off voltage	60V	60V	60V	60V	60V	60V
Equalization charging voltage	-	-	-	-	-	40~60V settable
Bulk charging voltage	53.2V	57.6V	56.8V	53.2V	49.2V	40~60V settable
Float charging voltage	53.2V	57.6V	56.8V	53.2V	49.2V	40~60V settable
Under-voltage alarm voltage	43.6V	46.8V	49.6V	46.4V	43.2V	40~60V settable
Under-voltage cut-off voltage	38.8V	42V	48.8V	45.6V	42V	40~60V settable
Discharging limit voltage	36.4V	39.2V	46.4V	43.6V	40.8V	40~60V settable
Over-discharge delay time	30s	30s	30s	30s	30s	1~30s settable
Equalization charging duration	-	-	-	-	-	0~600min settable
Equalization charging interval	-	-	-	-	-	0~250d settable
Bulk charging duration	120min settable	120min settable	120min settable	120min settable	120min settable	10~600min settable

6 Communication

6.1 Overview

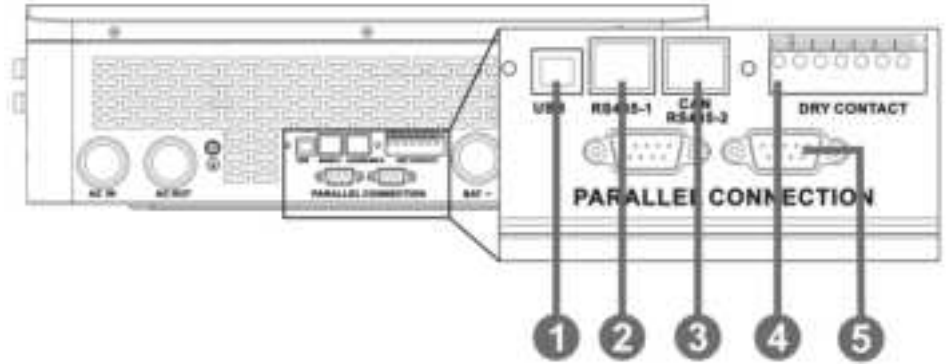

1	USB-B port	2	RS485-1 port	3	CAN/RS485-2 port
4	Dry contact port	5	Parallel connection port (reserved port, this model does not support parallel connection)		

6.2 USB-B Port

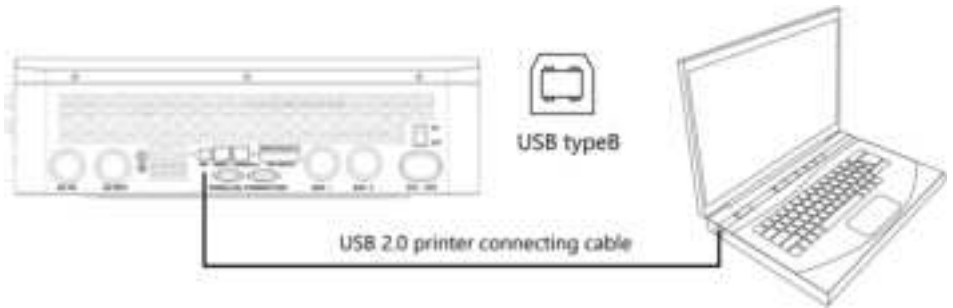

Users can use the upper computer software through the port to read and modify device parameters. If needing the installation package for the upper computer software, you can download it from the official website of PowMr, or contact us to get it.

6.3 RS485-1 Port

The WIFI port is used to connect to the Wi-Fi/GPRS data acquisition module, and then users can view the operation status and parameters of the inverter via the mobile APP.

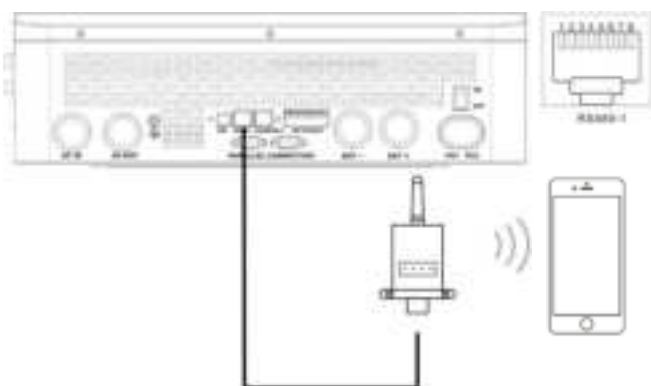

RJ45	Definition
Pin 1	5V
Pin 2	GND
Pin 3	/
Pin 4	/
Pin 5	/
Pin 6	/
Pin 7	RS485-A
Pin 8	RS485-B

NOTICE

The Wi-Fi/GPRS data acquisition module need to be purchased separately. User can scan the QR code to download the mobile APP.



6.4 RS485-2 Port

The RS485/CAN port is used to connect to the BMS of the Li-ion battery.

NOTICE

If you need the communication between the inverter and the BMS of the Li-ion battery, please contact us to understand the communication protocol, or upgrade the inverter to the corresponding software program.

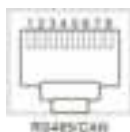

RJ45	Definition
Pin 1	5V
Pin 2	GND
Pin 3	/
Pin 4	CANH
Pin 5	CANL
Pin 6	/
Pin 7	RS485-A
Pin 8	RS485-B

6.5 Dry Contact Port

The dry contact port has 2 functions:

1. Battery temperature sampling
2. Remote generator start/stop

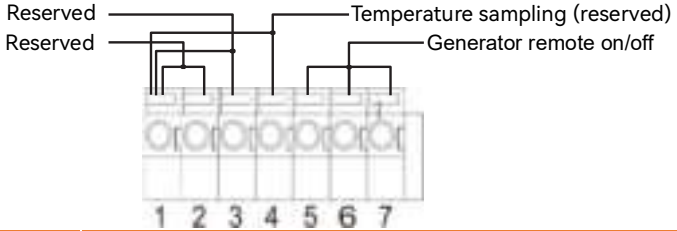

Function	Description
Remote switch on/off	Reserved
Switching signal output	Reserved
Temperature sampling (reserved)	Pin 1 & Pin 4 can be used for battery temperature sampling compensation.
Generator remote start/stop	When the voltage of battery reaches the under-voltage alarm voltage (parameter14) or voltage point of utility switch to battery (parameter 04), pin 6 to pin 5 normal open, pin 7 to pin 5 normal close. When the voltage of battery reaches the voltage point of battery switch to utility (parameter05) or battery is full. pin 6 to pin 5 normal close, pin 7 to pin 5 normal open. (Pin 5/6/7 outputs 125Vac/1A, 230Vac/1A,30Vdc/1A)

NOTICE

- If you need to use the remote start/stop function of the generator with dry contact, please ensure that the generator has an ATS and supports remote start/stop.

7 Fault Codes and Response Measures

7.1 Fault Codes

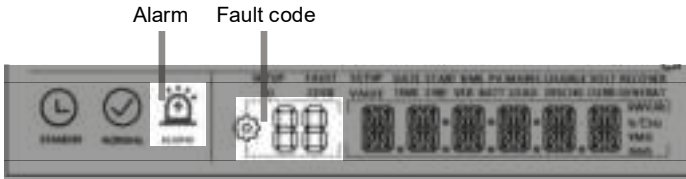

Fault Code	Meaning	Does it Affect the outputs	Instructions
01	BatVoltLow	Yes	Battery under-voltage alarm
02	BatOverCurrSw	Yes	Overcurrent software protection for average battery discharge current
03	BatOpen	Yes	Battery disconnected alarm
04	BatLowEod	Yes	Battery under-voltage stop discharging alarm
05	BatOverCurrHw	Yes	Battery over-current hardware protection
06	BatOverVolt	Yes	Battery over-voltage protection
07	BusOverVoltHw	Yes	Busbar over-voltage hardware protection
08	BusOverVoltSw	Yes	Busbar over-voltage software protection
09	PvVoltHigh	Yes	PV input over-voltage protection
10	PvBoostOCSw	No	Boost circuit over-current software protection
11	PvBoostOCHw	No	Boost circuit over-current hardware protection
12	SpiCommErr	Yes	SPI communication fault of master and slave chips
13	OverloadBypass	Yes	Bypass overload protection

14	OverloadInverter	Yes	Inverter overload protection
15	AcOverCurrHw	Yes	Inverter over-current hardware protection
16	AuxDspReqOffPWM	Yes	Slave chip request switch off failure
17	InvShort	Yes	Inverter short-circuit protection
18	Bussoftfailed	Yes	Busbar soft start failure
19	OverTemperMppt	No	MPPT heat sink over-temperature protection
20	OverTemperInv	Yes	Inverter heat sink over-temperature protection
21	FanFail	Yes	Fan failure
22	EEPROM	Yes	Memory failure
23	ModelNumErr	Yes	Wrong model
24	Busdiff	Yes	Busbar voltage imbalance
25	BusShort	Yes	Busbar short circuit
26	Rlyshort	Yes	Inverter output back flow to bypass
28	LinePhaseErr	Yes	Utility input phase fault
29	BusVoltLow	Yes	Busbar under-voltage protection
30	BatCapacityLow1	No	Battery SOC below 10% alarm (Only enable BMS take effect)
31	BatCapacityLow2	No	Battery SOC below 5% alarm (Only enable BMS take effect)
32	BatCapacityLowStop	Yes	Battery low-capacity OFF (Only enable BMS take effect)
34	CanCommFault	Yes	Parallel can communication fault
35	ParaAddrErr	Yes	Parallel ID (communication address) setting error
36	Balance currentOC	Yes	Balanced bridge arm overcurrent fault

37	ParaShareCurrErr	Yes	Parallel current sharing fault
38	ParaBattVoltDiff	Yes	Large battery voltage difference in parallel mode
39	ParaAcSrcDiff	Yes	Inconsistent mains input source in parallel mode
40	ParaHwSynErr	Yes	Hardware synchronization signal error in parallel mode
41	InvDcVoltErr	Yes	Inverter DC voltage error
42	SysFwVersionDiff	Yes	Inconsistent system firmware version in parallel mode
43	ParaLineContErr	Yes	Parallel connection fault
44	SerialNumbererror	Yes	Failure to set the serial number before leaving factory
45	Errorsettingofsplit-phasemode	Yes	Setting error of setting items in parallel mode
56	Lowinsulationresistancefault	No	Abnormally low earth impedance of PV1+ PV2+, and PV-
57	Leakagecurrentoverloadfault	Yes	System current leakage out of the standard
58	BMSComErr	No	BMS communication failure
60	BMSUnderTem	No	BMS under-temperature alarm (Only enable BMS take effect)
61	BMSOverTem	No	BMS over-temperature alarm (Only enable BMS take effect)
62	BMSOverCur	No	BMS over-current alarm (Only enable BMS take effect)
63	BMSUnderVolt	No	BMS under-voltage alarm (Only enable BMS take effect)
64	BMSOverVolt	No	BMS over-voltage alarm (Only enable BMS take effect)

7.2 Trouble Shooting

Fault Code	Meaning	Causality	Remedy
/	No screen display	There is no power input, or the device switch at its bottom is not turned on.	Check if the battery air-switch or PV air-switch has been closed; check if the switch is in "ON"; press any button on the screen to exit the screen sleep mode.
01	Battery under-voltage	The battery voltage is lower than the value set in parameter [14].	Charge the battery and wait until the battery voltage is higher than the value set in the parameter item [14].
03	Disconnected battery	The battery is not connected, or the BMS of the lithium-ion battery is in the discharge protection state.	Check whether the battery is reliably connected; check whether the circuit breaker of the battery is not closed; ensure that the BMS of the Li-ion battery can communicate properly.
04	Battery over-discharge	The battery voltage is lower than the value set in the parameter [12].	Manual reset: Power off and restart. Automatic reset: charge the battery so that the battery voltage is higher than the value set in the parameter item [35].
06	Battery over-voltage when charging	The battery is in the overvoltage state.	Manually power off and restart. Check to see if the battery voltage exceeds the limit. If it exceeds, the battery needs to be discharged until the voltage is below the battery's over-voltage recovery point.
13	Bypass over-load (software detection)	Bypass output power or output current overload for a certain period of time.	Reduce the load power and restart the device. Please refer to item 11 of the protection features for more details.

14	Inverter over-load (software detection)	Inverter output power or output current overload for a certain period of time.	
19	Heat sink of PV input over-temperature (software detection)	Heat sink of PV input temperature exceeds 90°C for 3s.	Resume normal charge and discharge when the temperature of the heat sink has cooled to below the over-temperature recovery temperature.
20	Heat sink of inversion over-temperature (software detection)	Heat sink of inversion temperature exceeds 90°C for 3s.	
21	Fan failure	Fan failure detects by hardware for 3s.	Manually toggle the fan after switching off to check for blockage by foreign objects.
26	AC Input relay short-circuit	Relay for AC input sticking	Manually power off and restart; if the fault reappears after restarting, You need to contact the after-sales service to repair the machine.
28	Utility input phase fault	AC input phase does not coincide with AC output phase	Ensure that the phase of the AC input is the same as the phase of the AC output, e.g. if the output is in split-phase mode, the input must also be in split-phase.

NOTICE

- If you encounter product faults that cannot be solved by the methods listed in the above table, please contact our after-sales service department for technical support, and do not disassemble the device by yourself.

8 Protection Function and Product Maintenance

8.1 Protection Function

No.	Protection Feature	Instruction
1	PV current-limiting protection	When the charge current or power of the configured PV array exceeds the rated current and power of the inverter, it will charge at the rated current and power.
2	PV input over-voltage	If the PV voltage exceeds the maximum value allowed by the hardware, the machine will report a fault and stop the PV boost to output a sinusoidal AC wave.
3	PV night reverse current protection	At night, the battery is prevented from discharging through the PV module because the battery voltage is greater than the voltage of PV module.
4	AC input over-voltage protection	When the AC input voltage of each phase exceeds 140V, the mains charging will be stopped and switched to the inverter mode.
5	AC input under-voltage protection	When the AC input voltage of each phase below 90V, the utility charging will be stopped and switched to the inverter mode.
6	Battery over-voltage protection	When the battery voltage reaches the over-voltage cut-off point, the PV and the utility will automatically stop charging to prevent the battery from being overcharged and damaged.
7	Battery under-voltage protection	When the battery voltage reaches the under-voltage cut-off point, the inverter will automatically stop the battery discharge to prevent damage from over-discharging the battery.
8	Battery over-current protection	After a period when the battery current exceeds that allowed by the hardware, the machine will switch off the output and stop discharging the battery.

9	AC output short-circuit protection	When a short-circuit fault occurs at the load output terminal, it will immediately turn off the output of AC voltage. Only after manually powering on the device, normal output restores.
10	Heat sink over-temperature protection	When the internal temperature of the inverter is too high, the inverter will stop charging and discharging; when the temperature returns to normal, the inverter will charge and discharge again.
11	Inverter over-load protection	<p>After triggering the overload protection the inverter will resume output after 3 minutes, 5 consecutive overloads will switch off the output until the inverter is restarted.</p> <p>(102%<load<110%) ±10%: error and output shutdown after 5min;</p> <p>(110% < load < 125%) ±10%: error and output shutdown after 10s;</p> <p>Load > 125% ±10%: error reported and output switched off after 5s.</p>
12	AC output reverse	Prevents AC back flow from the battery inverter to the bypass AC input.
13	Bypass over-current protection	Built-in AC input over-current protection circuit breaker.
14	Bypass phase inconsistency protection	When the phase of the bypass input and the phase of the inverter split do not match, the inverter disables switching to the bypass output to prevent the load from dropping out or short-circuiting when switching to the bypass.

8.2 Maintenance

To maintain optimum and long-lasting working performance, we recommend that the following items are checked twice a year.

1. Ensure that the airflow around the inverter is not blocked and remove any dirt or debris from the radiator.
2. Check that all exposed conductors are not damaged by sunlight, friction with other surrounding objects, dry rot, insect or rodent damage, etc. The conductors need to be repaired or replaced if necessary.
3. Verify that the indications and displays are consistent with the operation of the equipment, note any faults or incorrect displays and take corrective action if necessary.
4. Check all terminals for signs of corrosion, insulation damage, high temperatures or burning/discoloration and tighten terminal screws.
5. Check for dirt, nesting insects and corrosion, clean as required, Clean the insect screen regularly.
6. If the lightning arrester has failed, replace the failed arrester in time to prevent lightning damage to the inverter or other equipment of the user.

DANGER

- Before conducting any inspection or operation, please ensure that the inverter is disconnected from all power sources and that the capacitor is fully discharged to avoid the risk of electric shock.

Our company will not be held responsible for damage due to the following reasons:

1. Damage caused by improper use or use in the wrong location.
2. The open circuit voltage of the PV module exceeds the maximum allowable voltage.
3. The operating temperature exceeds the limited operating temperature range.
4. Unauthorized personnel dismantle, and repair the inverter.
5. Force majeure: damage during transportation or handling of the inverter.

9 Parameter Table

MODEL	POW-SunSmart 8K	POW-SunSmart 10K	CAN BE SET
INVERTER OUTPUT			
Rated Output Power	8,000W	10,000W	
Max. Peak Power	16,000W	20,000W	
Rated Output Voltage	120/240Vac (split phase/single phase)		Y
Rated AC Frequency	50/60Hz		Y
Waveform	Pure Sine Wave		
Switch Time	10ms (typical)		
Overload Protection	After triggering the overload protection the inverter will resume output after 3 minutes, 5 consecutive overloads will switch off the output until the inverter is restarted. (102%<load<110%) ±10%: error and output shutdown after 5min; (110% < load < 125%) ±10%: error and output shutdown after 10s. Load > 125% ±10%: error reported and output switched off after 5s.		
BATTERY			
Battery Type	Li-ion / Lead-Acid / User Defined		Y
Rated Battery Voltage	48Vdc		
Voltage Range	40-60Vdc		Y
Max. MPPT Charging Current	180A	200A	Y
Max. Mains/Generator Charging Current	100A	120A	Y
Max. Hybrid Charging Current	180A	200A	Y
PV INPUT			
Num. of MPP Trackers	2		
Max. PV array power	5,500W/5,500W		
Max. Input current	22/22A		

Max. Voltage of Open Circuit	500Vdc/500Vdc	
MPPT Voltage Range	125-425Vdc	
MAINS / GENERATOR INPUT		
Input Voltage Range	90-140Vac	
Frequency Range	50/60Hz	
Bypass Overload Current	63A	
EFFICIENCY		
MPPT Tracking Efficiency	99.9%	
Max. Battery Inverter Efficiency	92%	
GENERAL		
Dimensions	620*445*130mm (2*1.5*0.4ft)	
Weight	27kg (59.5lb)	
Protection Level	IP20, Indoor Only	
Operating Temperature Range	-10~55°C, >45°C derated (14~131°F, >113°F derated)	
Noise	<60dB	
Cooling Method	Internal Fan	
COMMUNICATION		
Embedded Interfaces	RS485 / CAN / USB / Dry contact	Y
External Modules (Optional)	Wi-Fi	Y
CERTIFICATION		
Safety	IEC62109-1, IEC62109-2, UL1741	
EMC	EN61000-6-1, EN61000-6-3, FCC 15 class B	
RoHS	Yes	



POWMr

SHENZHEN HEHEJIN INDUSTRIAL CO.,LTD

Tel/Fax: +86 755-28219903

Email: support@powmr.com

Web: www.powmr.com

Add: Henggang Street, Longgang District, Shenzhen, Guangdong, China